



320 Main Street - Buzzards Bay, MA 02532
508-759-4660 / 800-222-5932 / Fax 508-759-6001



The INFINITY PRODUCT MANUAL & INSTALLATION GUIDE

READ AND SAVE THESE INSTRUCTIONS

***WARNING:** TO REDUCE THE RISK OF FIRE, ELECTRIC SHOCK, OR INJURY TO PERSONS, OBSERVE THE FOLLOWING: Use this unit in the manner intended by the manufacturer. If you have any questions, contact the manufacturer. Before servicing or cleaning unit, switch power off at service panel and lock service panel to prevent power from being switched on accidentally. When the service disconnecting cannot be locked, securely fasten a prominent warning device, such as a tag, to the service panel.

When cutting or drilling into wall or ceiling, do not damage electrical wiring or other hidden utilities.

Never place a switch where it can be reached from a tub or shower.

Do not use this fan over a tub or shower.

Do not use this fan over cooking appliances.

***CAUTION:** For General Ventilation Use Only. Do Not Use To Exhaust Hazardous Or Explosive Materials And Vapors

***CAUTION:** This unit has an unguarded impeller. Do Not Use in Locations Readily Accessible to People or Animals.

The Best Location for *The Infinity*

- When selecting fan mounting location, consider the following:
 - Mounting *The Infinity* as far as possible from the interior air intake or exhaust points will minimize fan operating noise from being transmitted back through the duct work. Insulated flexible type duct work will result in much quieter operation.
 - The Infinity* location should allow sufficient access for service.
- Attach fan to the mounting bracket with the nuts and bolts provided. The wiring box should be positioned for easy access.
- Using the wood screws provided, attach the mounting brackets to a rafter or support beam at the selected location.
- Connect ductwork to the inlet and outlet collars of *The Infinity* using clamps or duct tape. When using insulated duct, it is recommended that the inner vinyl core be clamped or taped to the collars and that the vapor barrier surrounding the insulation be duct taped to the housing.

SPECIFICATIONS:

Duct Size (4):	10"
Duct Collar Length:	3" with Bead
Electrical Requirements:	115V, 60Hz, 3A (Total)
Overall Dimensions:	30"W x 17-1/8"H x 9.5D
Mounting Flange Dimensions	27" x 1-1/2"
Unit Weight	27 Lbs
Air Flow (each motor)	1070 cfm @ .1" Wg

Electrical Connections

DO NOT CONNECT POWER SUPPLY UNTIL FAN IS COMPLETELY INSTALLED.
MAKE SURE ELECTRICAL SERVICE TO THE FAN IS LOCKED IN "OFF" POSITION.

NOTE: *The Infinity* fan motors can be wired individually or as a pair.

1. Remove the cover from the junction box.
2. Remove the knockout on the junction box that is closest to the source wiring.
3. Attach a cable clamp.
4. Feed the source electrical wires into the electrical box and tighten the clamp.
5. Connect *The Infinity* fan motor wires to the source wires by twisting each pair together and then installing a wire nut over them.
6. Fasten the ground wire from the source electrical wires to the ground screw located in the junction box.
7. Replace the cover on the junction box.

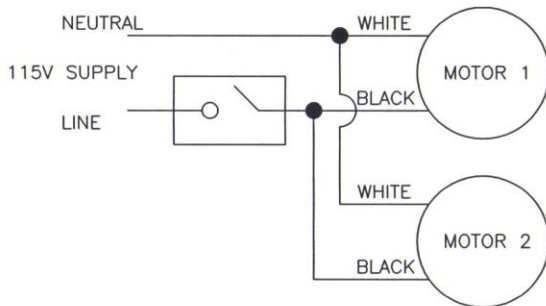

Single Control

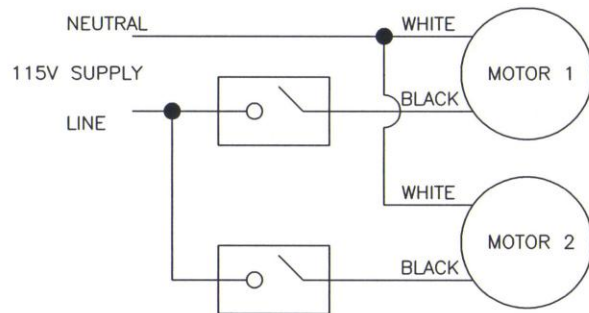

Independent Control

P/N: INFPG.1

LIMITED WARRANTY If, within the period of three years from the date of purchase, The INFINITY (the Product) is defective or malfunctions in normal home use, Tamarack Technologies, Inc. will repair or replace the Product, at its discretion. Customer is responsible for shipping charges.

CONDITIONS, EXCLUSIONS, AND LIMITATIONS

This Warranty is subject to the following conditions, exclusions and limitations:

THIS WARRANTY DOES NOT COVER PROBLEMS RESULTING FROM INSTALLATION, OPERATION OR MAINTENANCE THAT HAS BEEN UNDERTAKEN OTHER THAN IN ACCORDANCE WITH THE INSTRUCTIONS. THIS WARRANTY DOES NOT COVER PROBLEMS RESULTING FROM DEFECTS IN OR CAUSED BY ASSOCIATED EQUIPMENT (FURNACES, SOLARIA, ETC.); FROM REPAIRS OR MODIFICATIONS ATTEMPTED BY PERSONS OTHER THAN TAMARACK TECHNOLOGIES, INC.; FROM ABUSE, ACCIDENTAL OR SHIPPING DAMAGE OR ACTS OF GOD. THIS WARRANTY DOES NOT APPLY TO THE PRODUCT USED OUTSIDE THE UNITED STATES, ITS TERRITORIAL POSSESSIONS, AND CANADA. EXCEPT AS SET FORTH ABOVE, NO EXPRESS OR IMPLIED WARRANTY IS GIVEN OR AUTHORIZED BY TAMARACK TECHNOLOGIES, INC. AND ALL OTHER SUCH WARRANTIES ARE EXPRESSLY DISCLAIMED. ANY WARRANTY OR MERCHANTABILITY OF FITNESS FOR ANY PARTICULAR PURPOSE SHALL BE LIMITED TO THE WARRANTY HEREUNDER.

MOREOVER, ANY LIABILITY OF TAMARACK TECHNOLOGIES, INC. FOR THE PRODUCT SHALL BE LIMITED TO THE REPLACEMENT VALUE OF THE PRODUCT. IN NO EVENT SHALL TAMARACK TECHNOLOGIES, INC. BE LIABLE FOR ANY INCIDENTAL DAMAGES OR FOR ANY CONSEQUENTIAL PROPERTY OR COMMERCIAL DAMAGES, IRRESPECTIVE OF THE CAUSE THEREOF, OCCURRING EITHER DURING OR AFTER THE WARRANTY PERIOD, INCLUDING WITHOUT LIMITATION ANY DAMAGES TO ANY PART OF A BUILDING OR ITS CONTENTS. NOTE: SOME STATES DO NOT ALLOW THE EXCLUSION OR LIMITATION OF INCIDENTAL OR CONSEQUENTIAL DAMAGES AND SOME STATES DO NOT ALLOW LIMITATIONS ON HOW LONG AN IMPLIED WARRANTY LASTS, SO THE ABOVE LIMITATIONS OR EXCLUSIONS MAY NOT APPLY TO YOU. THIS WARRANTY GIVES YOU SPECIFIC LEGAL RIGHTS AND YOU MAY ALSO HAVE OTHER RIGHTS THAT VARY FROM STATE TO STATE. **PROOF OF PURCHASE REQUIRED.**