

CAUTION

1. Read all instructions carefully for safe operation and installation
2. To avoid possible electrical shock, be certain electricity is shut off before the installation.
3. All wiring must be in accordance with national and local electrical codes. Installation work and electrical wiring must be done by a qualified electrician.
4. Do not install over a heat source and directly over water. Generally only for ventilating indoor use.

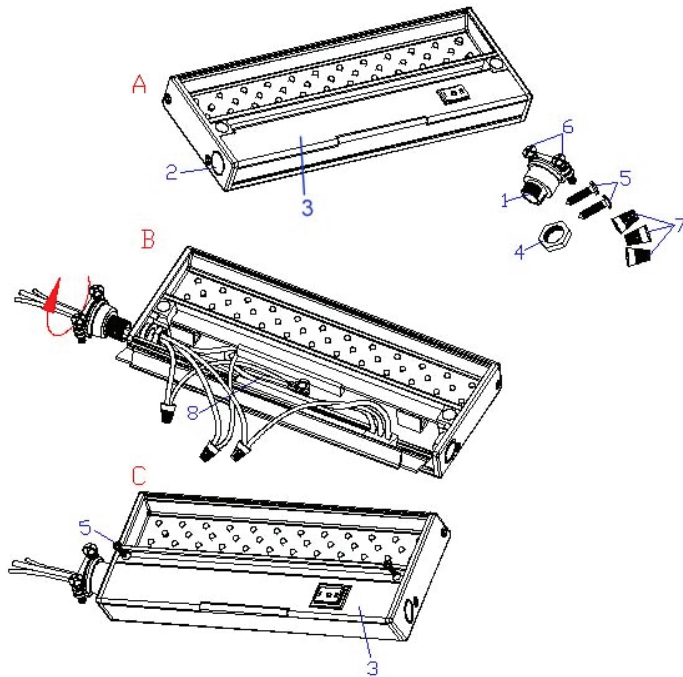

INSTALLATION

1. Remove all parts and hardware pack from carton (refer to Fig. A).

2. Insert connector (1) to the desired knockout (2) in housing (3). Knockout is removed by pressing with screwdriver.

3. Open the top cover of the housing (3). Connect the green wire (8) with a metal close-loop ring at end to the housing (3) by securing the close-loop ring in place between connector (1) and the housing (3). Then attach connector (1) and the close-loop ring to housing (3) by using lock nut (4) provided (refer to Fig. B).

4. Insert supply wires (not provided) through connector (1) and secure with the two screws (6) pre-installed on the connector (1). Attach black fixture wire to black supply wire, white fixture wire to white supply wire, green fixture grounding lead to grounding lead. **DO NOT MIX!** Use wire nuts (provided) to splice connections.

5. Mount housing (3) to desired surface firmly with the two mounting screws (5) provided (refer to Fig. C).

Note: For 40" fixtures, there is an additional pre-installed mounting

screw in the middle of housing. Please open the top cover and securely fasten the mounting screws.

Note: The assembly must be screwed solidly into wooden cabinet/ wall or stud.

6. Restore power and check installation

Note: Requires 120VAC/60Hz power supply for proper operation.

MAINTENANCE

Make sure power is switched off before servicing the unit.

CLEANING

Shut off the electricity before cleaning. Wipe all parts with a dry cloth.

WARNING! Never immerse electrical parts in liquid.

TROUBLESHOOTING

1. If light does not operate when the switch turns on, check that all wires are connected correctly. If it still cannot operate, call manufacturer for service.
2. If leakage, a rattling or humming noise, unusual smell, smoke is found during the operation, please disconnect the power and call the manufacturer.
3. Contact manufacturer for replacement lens.

Complete warranty details can be found at <http://nicorlighting.com/resources/warranty-info/led-under-cabinets>