

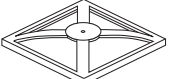

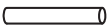

SQUARE UMBRELLA BASE

Read and follow all instructions before assembling and using this product. Keep these instructions in a safe place for future reference.

Assemble the umbrella base on a smooth, clean surface to avoid scratching or damaging the finish.

PARTS:

A	 Base (style may vary)	1
B	 Pole	1
C	 Adapter	1
D	 Adjustable Handle	1
E	 Flat Washer	1
F	 Bolt	1

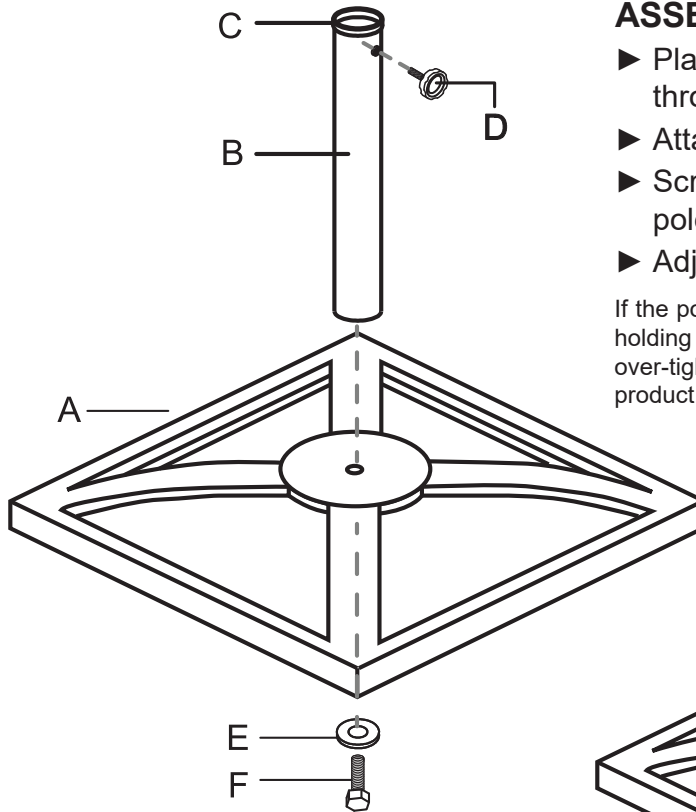

ASSEMBLY

- ▶ Place flat washer (E) onto bolt (F) and insert through the bottom of base (A).
- ▶ Attach pole (B) onto the base (A).
- ▶ Screw the adjustable handle (D) into umbrella pole (B).
- ▶ Adjust adapter (C) to fit your umbrella pole.

If the pole feels unstable, secure it more firmly to the base by holding the pole and tightening the bolt with a wrench. Do not over-tighten the bolt as it may strip the bolt and damage the product, invalidate the product warranty.

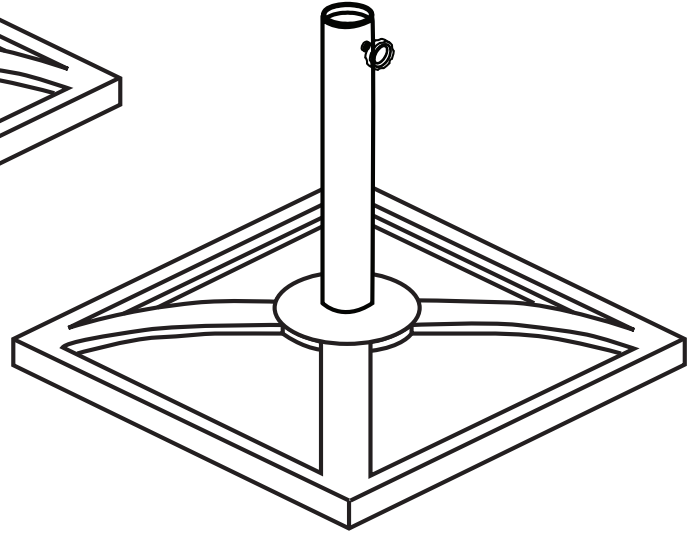

SAFETY STATEMENTS & MAINTENANCE

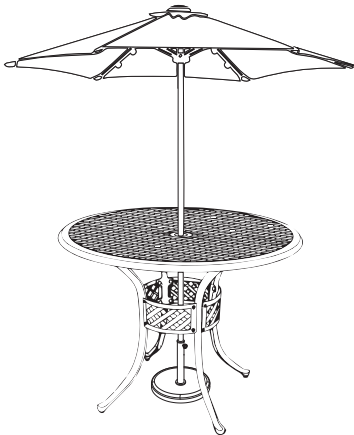

Correct Use

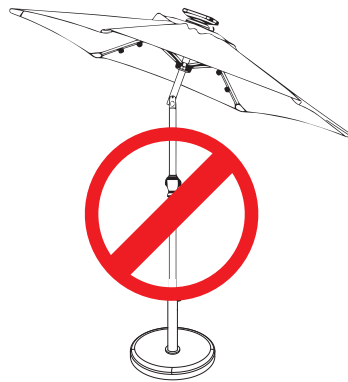

Incorrect Use

- This is not a freestanding umbrella base; the base must be used under a table designed to support an umbrella pole.
- Check for and empty standing water from the base.
- Do not stand on the base – it is only meant to support the weight of an umbrella.
- Store in a dry location when not in use – do not leave exposed to inclement weather.
- Clean with mild soap and water – use of harsh chemicals may damage the product and will invalidate the product warranty.
- Do not over-tighten the adjustable handle as it may damage your umbrella pole.
- Close patio umbrellas when not in use and remove umbrellas during high-wind conditions; the base is designed only to support an umbrella and will not protect your umbrella from wind damage.

Any modification or failure to follow the recommended care will void the product warranty.