



16" VARIABLE SPEED SCROLL SAW



Model # 3920
bit.ly/wenvideo

IMPORTANT:

Your new tool has been engineered and manufactured to WEN's highest standards for dependability, ease of operation, and operator safety. When properly cared for, this product will supply you years of rugged, trouble-free performance. Pay close attention to the rules for safe operation, warnings, and cautions. If you use your tool properly and for intended purpose, you will enjoy years of safe, reliable service.



NEED HELP? CONTACT US!

Have product questions? Need technical support?
Please feel free to contact us at:

 **800-232-1195** (M-F 8AM-5PM CST)

 techsupport@wenproducts.com

 WENPRODUCTS.COM

TABLE OF CONTENTS

Technical Data	2
General Safety Rules	3
Specific Safety Rules For Scroll Saw	5
Electrical Information	6
Know Your Scroll Saw	8
Assembly and Adjustments.....	9
Operation	15
Maintenance.....	19
Exploded View and Parts List	20
Warranty	22

TECHNICAL DATA

Model Number:	3920
Motor:	120 V, 60 Hz, 1.2 A
Speed:	400 to 1600 SPM
Throat Depth:	16"
Blade:	5" pinned & pinless
Blade Stroke:	9/16"
Cutting Capacity:	2" at 90°
Table tilt:	0° to 45° left
Overall dimensions:	26 - 3/8" by 13" by 14 - 3/8"
Weight:	33 lb

GENERAL SAFETY RULES

Safety is a combination of common sense, staying alert and knowing how your item works. **SAVE THESE SAFETY INSTRUCTIONS.**



WARNING: To avoid mistakes and serious injury, do not plug in your tool until the following steps have been read and understood.

1. **READ** and become familiar with this entire instruction manual. **LEARN** the tool's applications, limitations, and possible hazards.
2. **AVOID DANGEROUS CONDITIONS.** Do not use power tools in wet or damp areas or expose them to rain. Keep work areas well lit.
3. **DO NOT** use power tools in the presence of flammable liquids or gases.
4. **ALWAYS** keep your work area clean, uncluttered, and well lit. **DO NOT** work on floor surfaces that are slippery with sawdust or wax.
5. **KEEP BYSTANDERS AT A SAFE DISTANCE** from the work area, especially when the tool is operating. **NEVER** allow children or pets near the tool.
6. **DO NOT FORCE THE TOOL** to do a job for which it was not designed.
7. **DRESS FOR SAFETY.** Do not wear loose clothing, gloves, neckties, or jewelry (rings, watches, etc.) when operating the tool. Inappropriate clothing and items can get caught in moving parts and draw you in. **ALWAYS** wear non-slip footwear and tie back long hair.
8. **WEAR A FACE MASK OR DUST MASK** to fight the dust produced by sawing operations.



WARNING: Dust generated from certain materials can be hazardous to your health. Always operate the tool in a well-ventilated area and provide for proper dust removal. Use dust collection systems whenever possible.

9. **ALWAYS** remove the power cord plug from the electrical outlet when making adjustments, changing parts, cleaning, or working on the tool.
10. **KEEP GUARDS IN PLACE AND IN WORKING ORDER.**
11. **AVOID ACCIDENTAL START-UPS.** Make sure the power switch is in the OFF position before plugging in the power cord.
12. **REMOVE ADJUSTMENT TOOLS.** Always make sure all adjustment tools are removed from the saw before turning it on.
13. **NEVER LEAVE A RUNNING TOOL UNATTENDED.** Turn the power switch to OFF. Do not leave the tool until it has come to a complete stop.

GENERAL SAFETY RULES

14. **NEVER STAND ON A TOOL.** Serious injury could result if the tool tips or is accidentally hit. **DO NOT** store anything above or near the tool.
15. **DO NOT OVERREACH.** Keep proper footing and balance at all times. Wear oil-resistant rubber-soled footwear. Keep the floor clear of oil, scrap, and other debris.
16. **MAINTAIN TOOLS PROPERLY.** **ALWAYS** keep tools clean and in good working order. Follow instructions for lubricating and changing accessories.
17. **CHECK FOR DAMAGED PARTS.** Check for alignment of moving parts, jamming, breakage, improper mounting, or any other conditions that may affect the tool's operation. Any part that is damaged should be properly repaired or replaced before use.
18. **MAKE THE WORKSHOP CHILDPROOF.** Use padlocks and master switches and **ALWAYS** remove starter keys.
19. **DO NOT** operate the tool if you are under the influence of drugs, alcohol, or medication that may affect your ability to properly use the tool.
20. **USE SAFETY GOGGLES AT ALL TIMES** that comply with ANSI Z87.1. Normal safety glasses only have impact resistant lenses and are not designed for safety. Wear a face or dust mask when working in a dusty environment. Use ear protection such as plugs or muffs during extended periods of operation.

SPECIFIC RULES FOR THE SCROLL SAW



WARNING: Do not operate the scroll saw until it is assembled and adjusted. Do not operate the scroll saw until you have read and understood both the following instructions and the warning labels on the scroll saw.

BEFORE OPERATING:

1. Check for both proper assembly and proper alignment of moving parts.
2. Understand the function and proper use of the ON/OFF switch.
3. Know the condition of the scroll saw. If any part is missing, bent, or does not operate properly, replace the component before attempting to operate the scroll saw.
4. Determine the type of work you are going to be doing. Properly protect your body including your eyes, hands, face, and ears.
5. To avoid injury caused by pieces thrown from accessories, use only recommended accessories designed for this saw. Follow the instructions supplied with the accessory. The use of improper accessories may cause risk of injury.
6. To avoid contact with rotating equipment:
 - Do not put your fingers in a position where they risk contacting the blade if the work piece unexpectedly shifts or your hand unexpectedly slips.
 - Do not cut a work piece too small to be held safely.
 - Do not reach under the scroll saw table when the motor is running.
 - Do not wear loose clothing or jewelry. Roll long sleeves above the elbow. Tie back long hair.
7. To avoid injury from accidental startups of the scroll saw:
 - Make sure to turn OFF the switch and unplug the power cord from the electric outlet before changing the blade, performing maintenance or making adjustments.
 - Make sure the switch is OFF before plugging in the power cord to an electric outlet.
8. To avoid injury from a fire hazard, do not operate the scroll saw near flammable liquids, vapors or gases.
9. To avoid back injury:
 - Obtain help when raising the scroll saw more than 10 inches (25.4 cm). Bend your knees when lifting the scroll saw.
 - Carry the scroll saw by its base. Do not move the scroll saw by pulling on the power cord. Pulling on the power cord could cause damage to the insulation or the wire connections resulting in electric shock or fire.

SPECIFIC RULES FOR THE SCROLL SAW

WHEN OPERATING THE SCROLL SAW

1. To avoid injury from unexpected scroll saw movement:
 - Use the scroll saw on a firm level surface with adequate space for handling and supporting the work piece.
 - Be sure the scroll saw cannot move when operated. Secure the scroll saw to a workbench or table with wood screws or bolts, washers and nuts.
2. Before moving the scroll saw, unplug the power cord from the electrical outlet.
3. To avoid injury from kickback:
 - Hold the work piece firmly against the tabletop.
 - Do not feed the work piece too fast while cutting. Only feed the work piece at the rate the saw will cut.
 - Install the blade with the teeth pointing downward.
 - Do not start the saw with the work piece pressing against the blade. Slowly feed the work piece into the moving blade.
 - Use caution when cutting round or irregularly shaped work pieces. Round items will roll and irregularly shaped work pieces can pinch the blade.
4. To avoid injury when operating the scroll saw:
 - Obtain advice from a qualified person if you're not thoroughly familiar with the operation of scroll saws.
 - Before starting the saw, make sure the blade tension is correct. Recheck and adjust tension as needed.
 - Make sure the table is locked into position before starting the saw.
 - Do not use dull or bent blades.
 - When cutting a large work piece, make sure the material is supported at the table height.
 - Turn the saw OFF and unplug the power cord if the blade jams in the work piece. This condition is usually caused by sawdust clogging the line you are cutting. Wedge open the work piece and back out the blade after turning off and unplugging the machine.

ELECTRICAL INFORMATION

GROUNDING INSTRUCTIONS

IN THE EVENT OF A MALFUNCTION OR BREAKDOWN, grounding provides the path of least resistance for an electric current and reduces the risk of electric shock. This tool is equipped with an electric cord that has an equipment grounding conductor and a grounding plug. The plug **MUST** be plugged into a matching outlet that is properly installed and grounded in accordance with **ALL** local codes and ordinances.

DO NOT MODIFY THE PLUG PROVIDED. If it will not fit the outlet, have the proper outlet installed by a licensed electrician.

ELECTRICAL INFORMATION

IMPROPER CONNECTION of the equipment grounding conductor can result in electric shock. The conductor with the green insulation (with or without yellow stripes) is the equipment grounding conductor. If repair or replacement of the electric cord or plug is necessary, **DO NOT** connect the equipment grounding conductor to a live terminal.

CHECK with a licensed electrician or service personnel if you do not completely understand the grounding instructions or whether the tool is properly grounded.

USE ONLY THREE-WIRE EXTENSION CORDS that have three-pronged plugs and outlets that accept the tool's plug as shown in Fig. A. Repair or replace a damaged or worn cord immediately.

CAUTION: In all cases, make certain the outlet in question is properly grounded. If you are not sure, have a licensed electrician check the outlet.



WARNING: This tool is for indoor use only. Do not expose to rain or use in damp locations.
Guidelines for using extension cords

Make sure your extension cord is in good condition. When using an extension cord, be sure to use one heavy enough to carry the current your product will draw. An undersized cord will cause a drop in line voltage resulting in loss of power and overheating. The table below shows the correct size to be used according to cord length and nameplate ampere rating. When in doubt, use a heavier cord. The smaller the gauge number, the heavier the cord.

AMPERAGE	REQUIRED GAUGE FOR EXTENSION CORDS			
	25 ft.	50 ft.	100 ft.	150 ft.
1.2 A	18 gauge	16 gauge	16 gauge	14 gauge

Make sure your extension cord is properly wired and in good condition. Always replace a damaged extension cord or have it repaired by a qualified person before using it.

Protect your extension cords from sharp objects, excessive heat and damp/wet areas.

Use a separate electrical circuit for your tools. This circuit must not be less than a #12 wire and should be protected with a 15 A time-delayed fuse. Before connecting the motor to the power line, make sure the switch is in the OFF position and the electric current is rated the same as the current stamped on the motor nameplate. Running at a lower voltage will damage the motor.

WARNING: This tool must be grounded while in use to protect the operator from electric shock.

KNOW YOUR SCROLL SAW

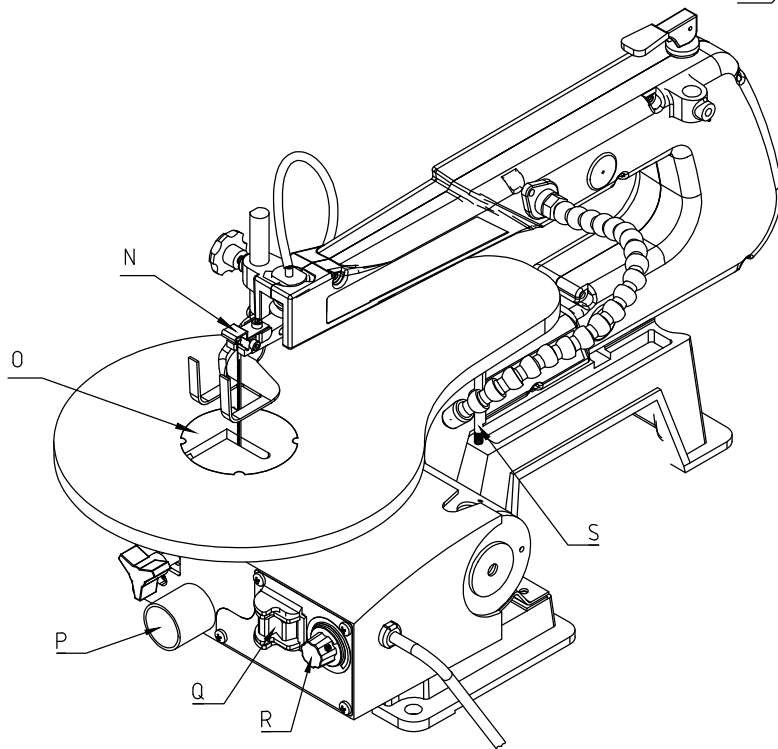
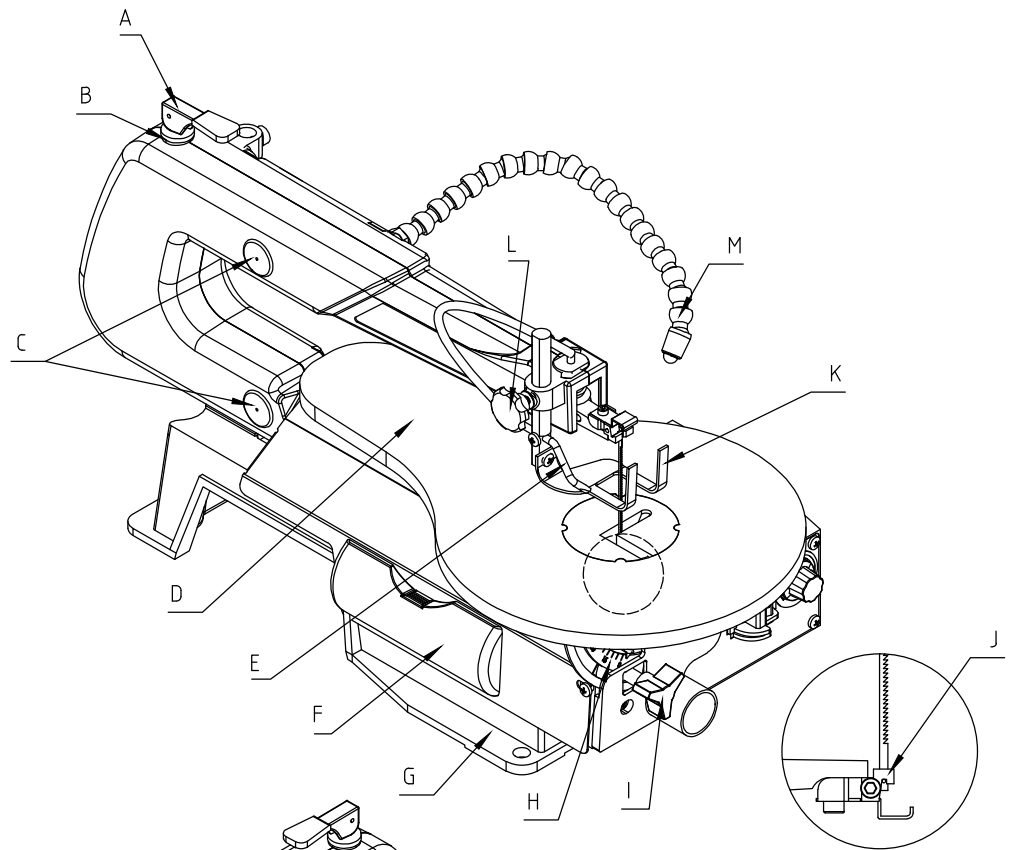

- A - Blade Tension Knob Motor:
- B - Dust Cover
- C - Rubber Bearing Covers
- D - Table
- E - Sawdust Blower
- F - Storage Area
- G - Base
- H - Bevel Scale and Pointer
- I - Table/Bevel Lock Knob
- J - Lower Blade Holder
- K - Blade Guard Foot
- L - Blade Guard Foot Lock Knob
- M - LED Light
- N - Upper Blade Holder
- O - Table Insert
- P - Sawdust Collection Port
- Q - ON/OFF Switch
- R - Speed Control Knob
- S - Table Adjusting Screw

ASSEMBLY AND ADJUSTMENTS

UNPACKING

Carefully unpack the scroll saw and all of its parts. Compare them against the list below. Do not discard the carton or any packaging until the scroll saw is completely assembled.

CAUTION: do not lift the saw by the arm that holds the blade. The saw will be damaged.



WARNING: To avoid injury from accidental startups, turn switch OFF and remove the plug from the power source outlet before making any adjustments.

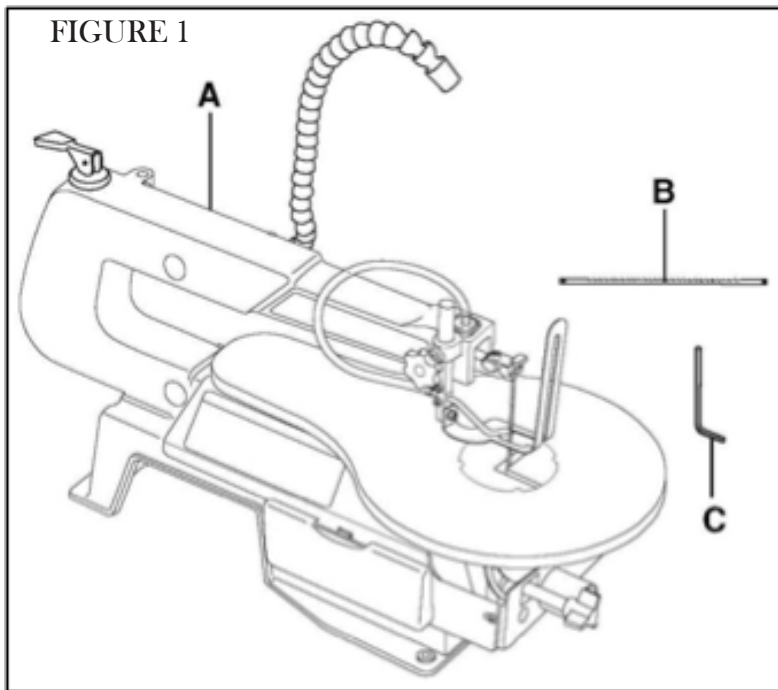

INCLUDES (Fig. 1)

- A - Scroll saw with attached light
- B - Extra pin blade
- C - Wrench

STORAGE AREA (Fig. 2)

A convenient storage location for the hex key and extra blade can be found beneath the saw's table.

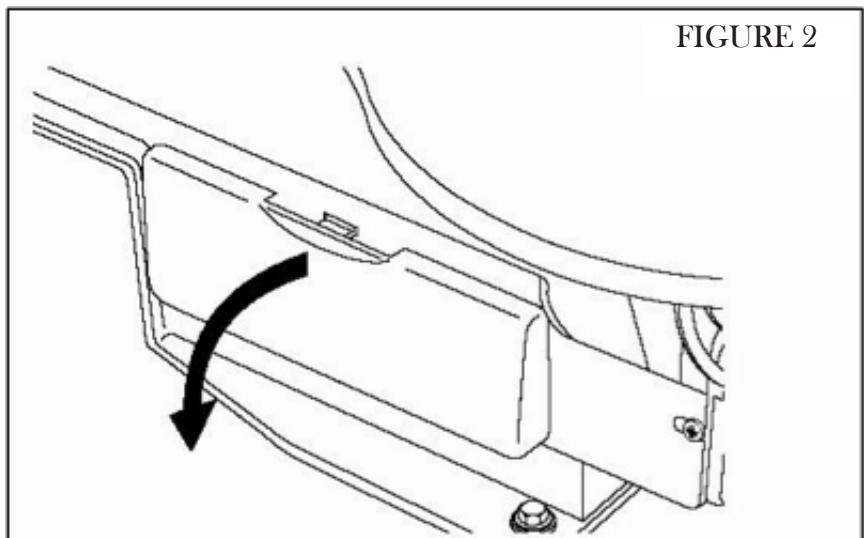

ASSEMBLY AND ADJUSTMENTS

Prior to making adjustments, mount the scroll saw on a stable surface. See “Bench mounting the saw.”

ADJUSTMENTS

ALIGN THE BEVEL INDICATOR (Fig. 3-6)

The bevel indicator has been factory adjusted. It should be rechecked prior to use for best operation.

1. Remove the blade guard foot (1) using the hex key (2) to loosen the screw.

2. Loosen the table bevel lock knob (3) and move the table until it is approximately at a right angle to the blade.

3. Loosen the locking nut (5) on the table adjusting screw (6) under the table by turning it counter-clockwise. Lower the table adjusting screw by turning it clockwise.

4. Use a combination square (7) to set the table exactly 90° to the blade (8). If there is space between the square and blade, adjust the table angle until the space is closed.

5. Lock the table bevel lock knob under the table (3) to prevent movement.

6. Tighten the adjusting screw under the table until the tip of the screw touches the table. Tighten the lock nut.

7. Loosen the screw (4) holding the bevel scale pointer and position pointer to 0°. Tighten the screw.

8. Attach the blade guard foot (1) using the hex key (2) so the foot rests flat against the table. Tighten the screw.

Note: Avoid setting the edge of the table against the top of the motor. This can cause excess noise when the saw is running.

FIGURE 3

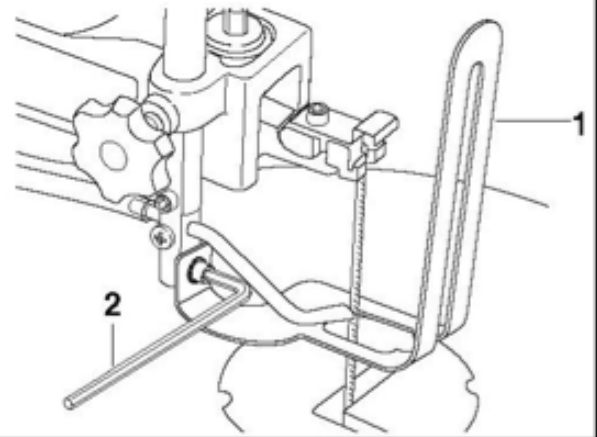

FIGURE 4

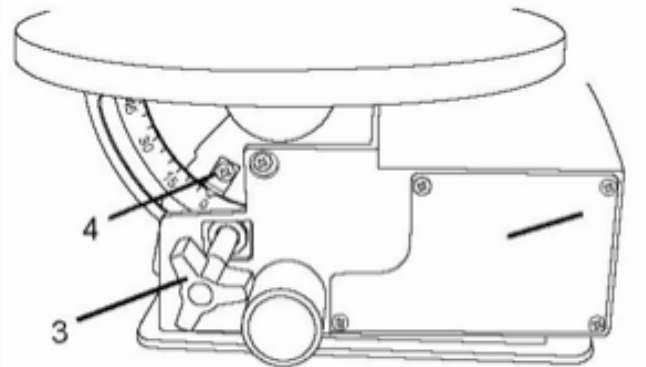

FIGURE 5

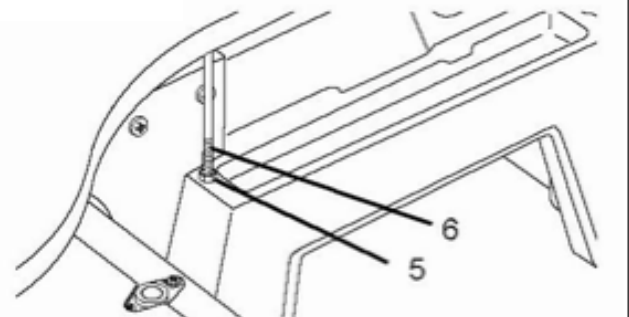
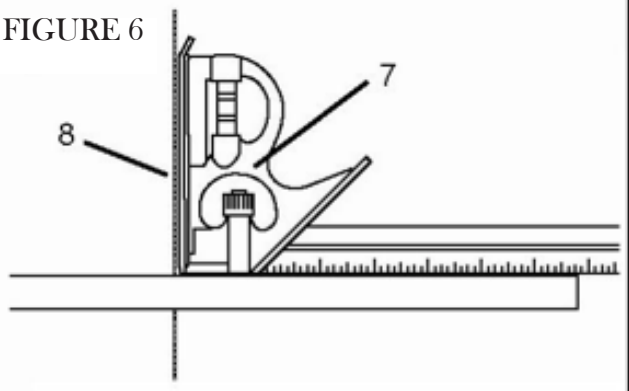

FIGURE 6



ASSEMBLY AND ADJUSTMENTS

BENCH MOUNTING THE SAW (Fig. 7-8)

Before operating the saw, it must be firmly mounted to a workbench or another rigid frame. Use the base of the saw to mark and pre-drill the mounting holes. If the saw is to be used in one location, permanently secure it to the work surface using wood screws if mounting to wood. Use bolts, washers, and nuts if mounting into metal. To reduce noise and vibration, install a soft foam pad (not supplied) between the scroll saw and the workbench.

Note: mounting hardware not included.



WARNING - to reduce the risk of injury:

- When carrying the saw, hold it close to your body to avoid injury to your back. Bend your knees when lifting the saw.
- Carry the saw by the base. Do not carry the saw by the power cord.
- Secure the saw in a position where people cannot stand, sit, or walk behind it. Debris thrown from the saw could injure people standing, sitting, or walking behind it.
- Secure the saw on a firm, level surface where the saw cannot rock. Make sure there is adequate room for handling and properly supporting the work piece.

FIGURE 7

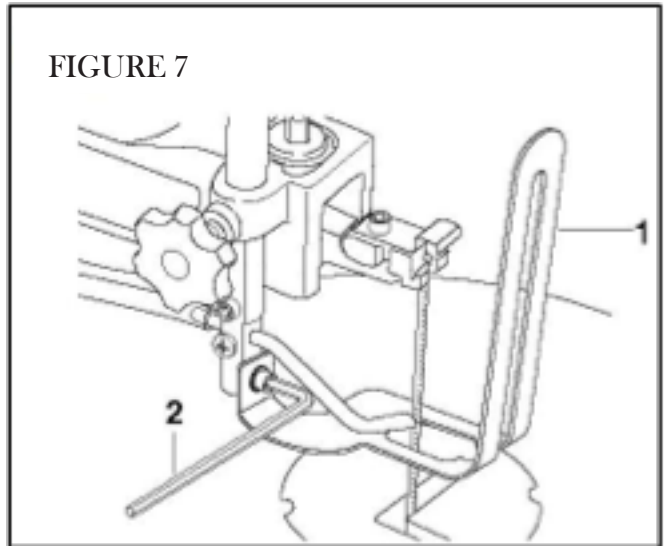
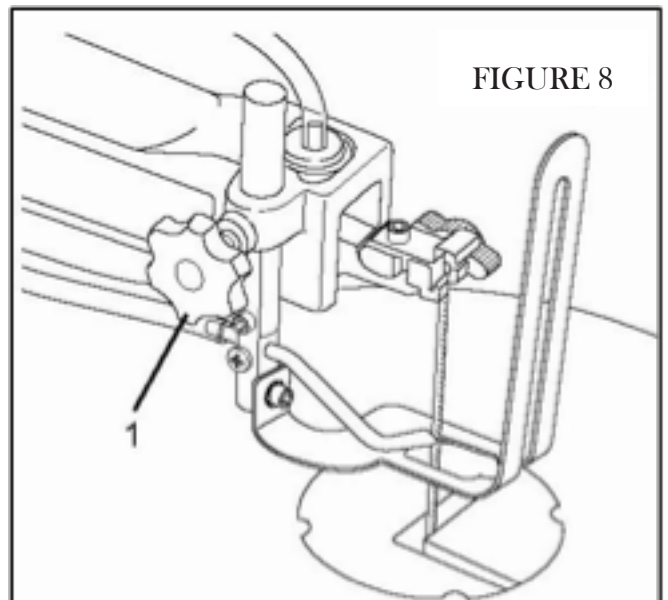

FIGURE 8



Blade guard foot adjustment (Fig. 7 and 8)

When cutting at angles, the blade guard foot should be adjusted so it is parallel to the table and rests flat above the work piece.

1. To adjust, loosen the screw (2), tilt the foot (1) so it is parallel to the table, and tighten the screw.
2. Loosen the height adjustment knob to raise or lower the foot until it just rests on top of the work piece. Tighten the knob.

ASSEMBLY AND ADJUSTMENTS

ADJUSTING THE DUST BLOWER (Fig. 9)

For best results, the dust blower tube (1) should be adjusted to direct air at both the blade and the work piece.

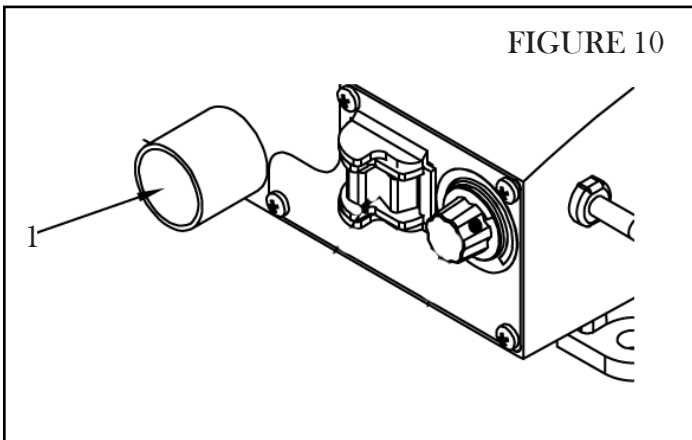
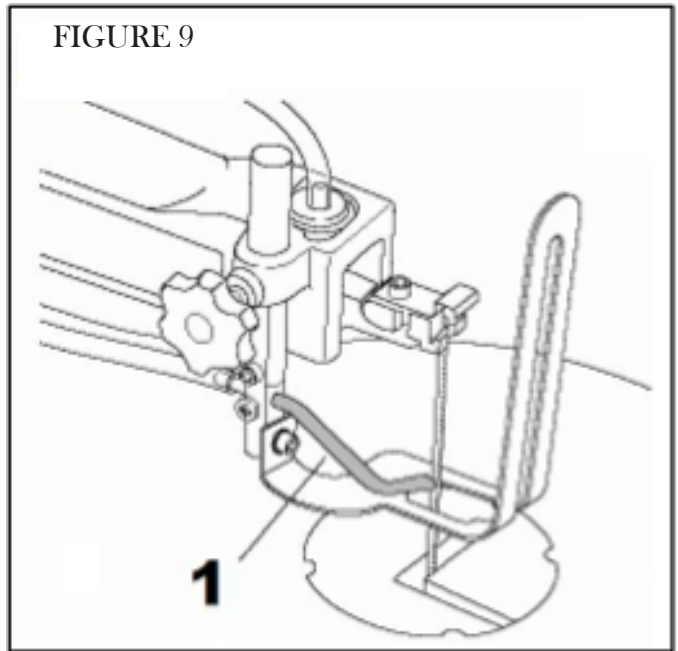

SAWDUST COLLECTION PORT (Fig. 10 and 11)

This scroll saw allows a hose or vacuum accessory (not provided) to be connected to the dust chute (1). If excessive sawdust buildup occurs inside the base, use a wet/dry vacuum cleaner or manually remove sawdust by removing the screws (2) and metal plate on the left side of the saw. Reattach the metal plate and screws before starting the saw. This will keep your saw cutting efficiently.

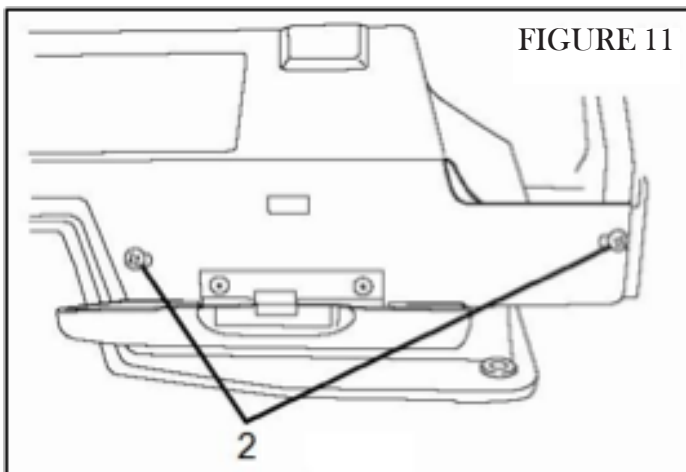

ASSEMBLY AND ADJUSTMENTS

BLADE SELECTION (Fig. 12)

This scroll saw accepts 5" length pin end and pinless blades, with a wide variety of blade thicknesses and widths. The type of material and intricacies of cutting operations will determine the number of teeth per inch. Always select the narrowest blades for intricate curve cutting and the widest blades for straight and large curve cutting operations. The following table represents suggestions for various materials. Use this table as an example, but with practice, personal preference will be the best selection method.

When choosing a blade, use very fine, narrow blades to scroll cut in thin wood 1/4" thick or less. Use wider blades for thicker materials but this will reduce the ability to cut tight curves. A smaller blade width can cut circles with smaller diameters.

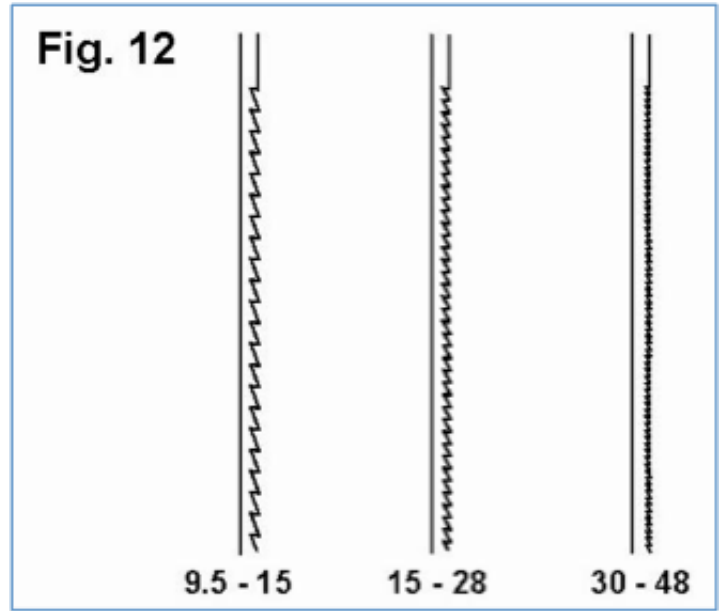

Note: Thinner blades will have more possibilities for blade deflection when cutting angles are not perpendicular to the table.

TEETH PER INCH	BLADE WIDTH	BLADE THICKNESS	BLADE SPM	MATERIAL CUT
10 to 15	.11"	.018"	500 to 1200 SPM	Medium turns on 1/4" to 1-3/4" wood, soft metal, hardwood
15 to 28	.055" to .11"	.01 to .018"	800 to 1700 SPM	Small turns on 1/8" to 1-1/2" wood, soft metal, hardwood
30 to 48	.024" to .041"	.012" to .019"	Varies	Non-ferrous metals/hardwoods using very slow speeds

BLADE CARE

To maximize the life of your scroll saw blades:

1. Do not bend blades when installing.
2. Always set proper blade tension.
3. Use the right blade (see instruction on replacement blade packaging for proper use).
4. Feed the work correctly into the blade.
5. Use thin blades for intricate cutting.



CAUTION: Any and all servicing should be performed by a qualified service center.

ASSEMBLY AND ADJUSTMENTS

BLADE REMOVAL AND INSTALLATION (Fig. 13 to 15)



WARNING: To prevent personal injury, always turn saw OFF and disconnect the plug from the power source before changing blades or making adjustments.

This saw uses pin-end and pinless blades. Pin-end blades are thicker for stability and for faster assembly. They provide faster cutting on a variety of materials.

Note: When installing pin-end blades, the slot on the blade holder must be slightly wider than the thickness of the blade. After the blade is installed, the blade tension mechanism will keep it in place.

1. To remove the blade, loosen the tension on it by lifting up and turning the blade tension lever (1) counterclockwise.

2. Remove the table insert. Carefully pry up on the table insert to remove.

3. Loosen the upper blade holder knob (2) and lower blade holder knob (3). Push down on the upper blade holder to remove the blade from the holder. Remove the blade from the lower blade holder.

CAUTION: Install the blade with the teeth pointing downward.

4. To install the blade, hook the blade in the recess of the lower blade holder.

5. While pushing down on the upper blade holder, insert the blade into the slot of the holder.

6. Tighten the upper and lower blade holder screws.

7. Move the blade tension lever down and turn the blade tension lever (1) clockwise until you feel the slack in the blade removed. Make sure the blade is properly located in the blade holders. Turn the blade tension knob an additional full clockwise turn. This amount of blade pressure should do well for most cutting operations.

8. Snap the table insert back into place.

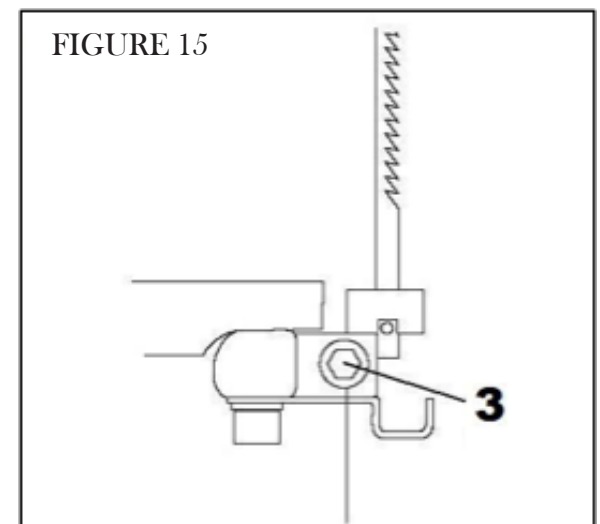
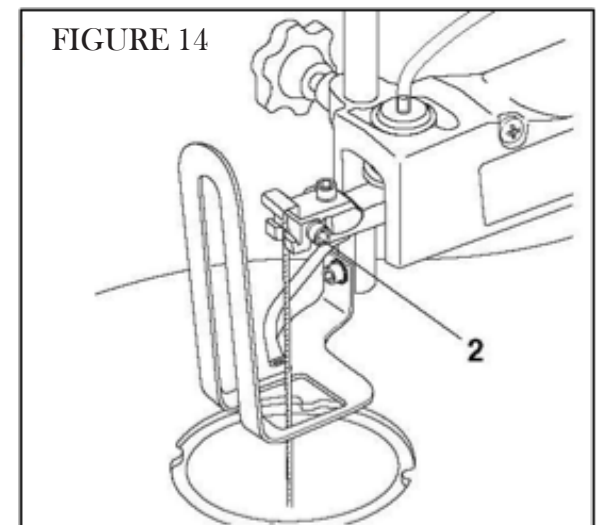
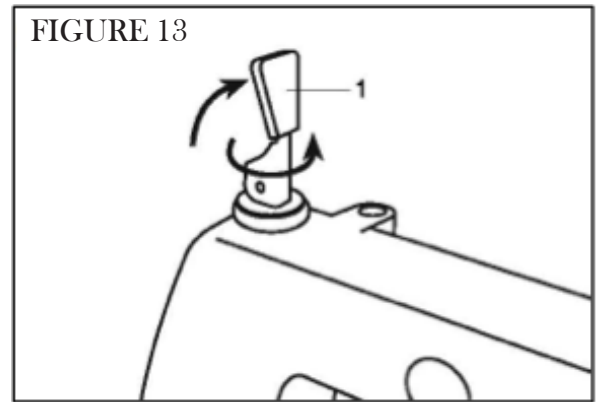

OPERATION

RECOMMENDATIONS FOR CUTTING

A scroll saw is basically a curve-cutting machine. It can also be used for straight cutting and beveling or angle cutting operations. Please read and understand the following items before attempting to use the saw.

1. When feeding the work piece into the blade do not force it against the blade. This could cause blade deflection. Allow the saw to cut the material by guiding the work piece into the blade as it cuts.
2. The blade teeth cut material **ONLY** on the down stroke.
3. Guide the wood into the blade slowly because the teeth of the blade are very small and remove wood only on the down stroke.
4. There is a learning curve for each person using this saw. During that period of time it is expected that some blades will break until you learn how to use the saw.
5. Best results are achieved when cutting wood one inch thick or less.
6. When cutting wood thicker than one inch, guide the wood very, very slowly into the blade and take extra care not to bend or twist the blade while cutting in order to maximize blade life.
7. Teeth on scroll saw blades wear out and the blades must be replaced frequently for best cutting results. Scroll saw blades generally stay sharp for 1/2 hour to 2 hours of cutting.
8. To get accurate cuts, be prepared to compensate for the blade's tendency to follow the wood grain.
9. This scroll saw is primarily designed to cut wood or wood products. For cutting precious and non-ferrous metals, the variable control switch must be set at very slow speeds.
10. When choosing a blade, use very fine, narrow blades to scroll cut in thin wood 1/4" thick or less. Use wider blades for thicker materials. This, however, will reduce the ability to cut tight curves.
11. Blades wear down faster when cutting plywood or very abrasive particle board. Angle cutting in hardwoods also wears blades down faster.

OPERATION

ON/OFF & SPEED CONTROL SWITCH (Fig. 16)

Always wait for the saw to come to a complete stop before restarting.

1. To turn the saw on, flip the ON/OFF switch to ON (2). When first starting the saw, it is best to move the speed control knob (1) to the middle speed position.
2. Adjust the blade speed to the desired setting between 400 to 1600 strokes per minute (SPM). Turning the control knob clockwise increases speed; turning it counterclockwise reduces speed.
3. To turn the saw off, flip the ON/OFF switch back to OFF (2) in. Note: You can lock the scroll saw by removing the tip of the switch. Just pry off the switch lock with your fingernails to prevent accidental operation.

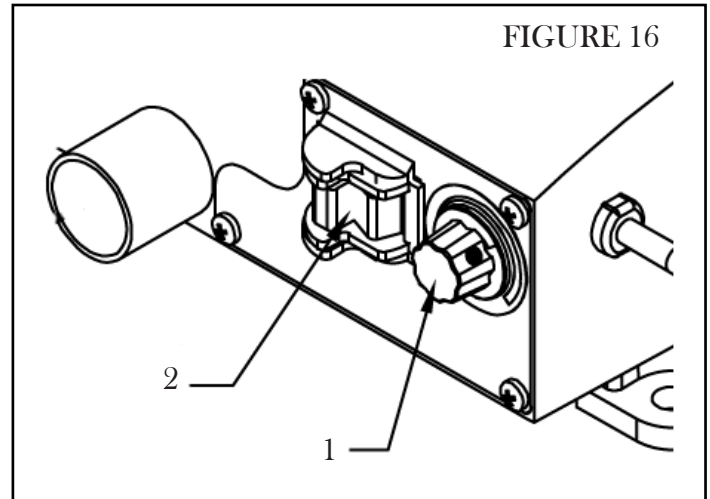

WARNING: To avoid injury from accidental start-ups, always turn the switch OFF and unplug the scroll saw before moving the tool, replacing the blade, or making adjustments.

FREEHAND CUTTING (Fig. 17)

1. Lay out desired design, or secure design to the work piece.
2. Raise the blade guard foot (1) by loosening the height adjustment knob (2).
3. Position the work piece against the blade and place the blade guard foot against the top surface of the work piece.
4. Secure the blade guard foot (1) by tightening the height adjustment knob (2).
5. Remove the work piece from the blade prior to turning the scroll saw ON.

CAUTION: In order to avoid uncontrollable lifting of the work piece and to reduce blade breakage, do not turn the switch on while the work piece is against the blade.

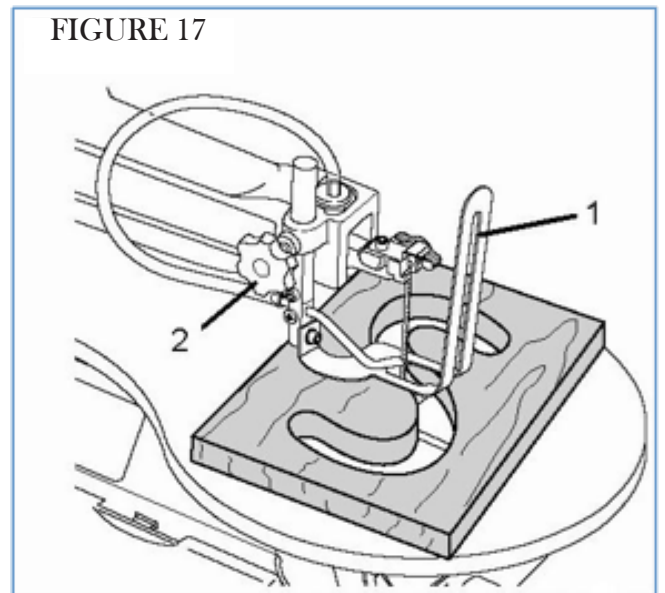

6. Slowly feed the work piece into the blade by guiding and pressing the work piece down against the table.

CAUTION: Do not force the leading edge of the work piece into the blade. The blade will deflect, reducing accuracy of cut, and may break.

7. When the cut is complete, move the trailing edge of the work piece beyond the blade guard foot. Turn the switch OFF.

OPERATION

ANGLE CUTTING (BEVELING) (Fig. 18)

1. Layout or secure design to work piece.
2. Move the blade guard foot to the highest position by loosening the height adjustment knob (1). Retighten.
3. Tilt the table to the desired angle by loosening the table bevel lock handle (2). Move the table to the proper angle using the degree scale and the pointer (3).
4. Tighten the table bevel lock handle (2).
5. Loosen the blade guard screw, and tilt the blade guard to the same angle as the table. Retighten the blade guard screw.
6. Position the work piece on the right side of the blade. Lower the blade guard foot against the surface by loosening the height adjustment knob. Retighten.
7. Follow steps 5 to 7 under Freehand cutting.

FIGURE 18

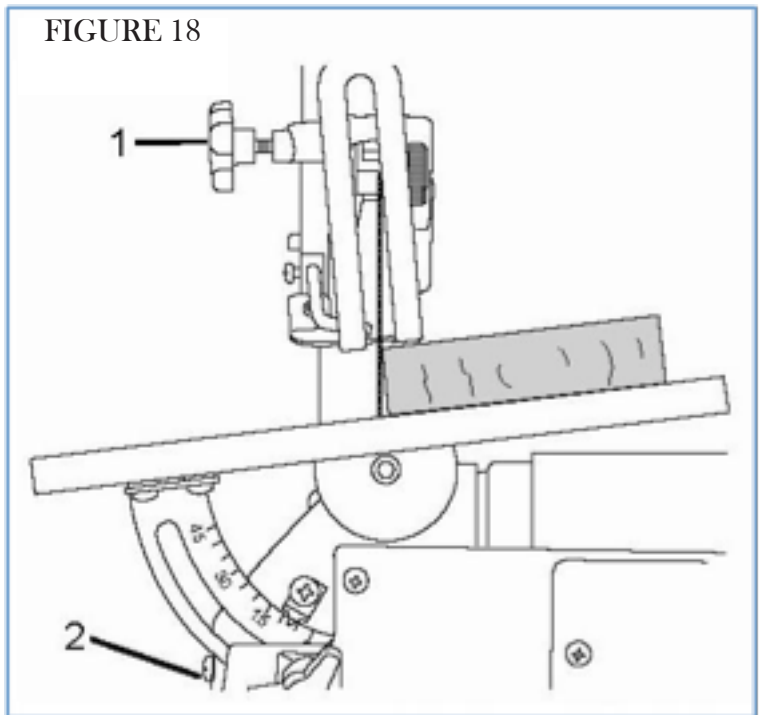

INTERIOR CUTTING (Fig. 19)

1. Lay out the design on the work piece. Drill a 1/4" hole in the work piece.
2. Remove the blade. See Blade removal and installation.
3. Place the work piece on the saw table with the hole in the work piece over the access hole in the table.
4. Install a blade through the hole in the work piece.
5. Follow steps 3-7, under Freehand cutting.
6. When finished making the interior scroll cuts simply turn the scroll saw OFF. Unplug the saw before removing the blade from the blade holder. Remove the work piece from the table.

FIGURE 19

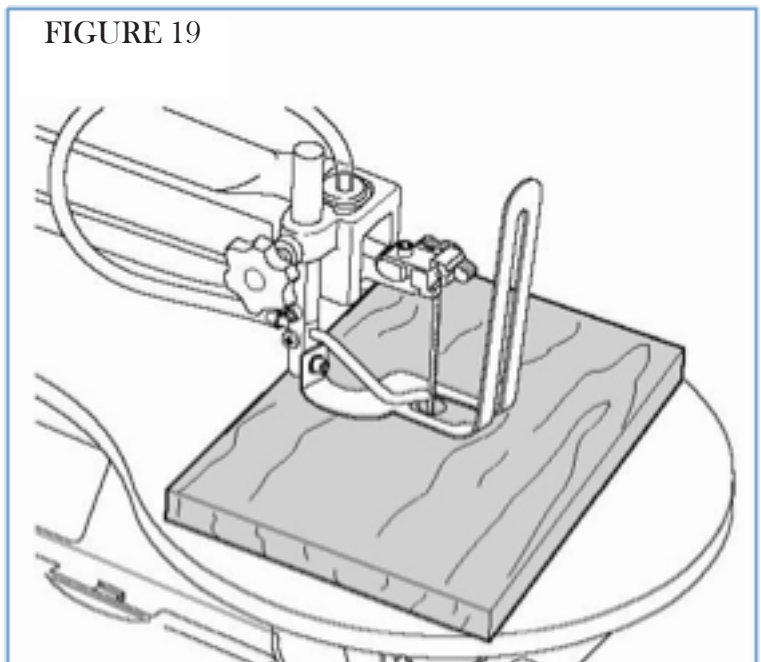

OPERATION

RIP OR STRAIGHT LINE CUTTING (Fig. 20)

1. Raise the blade guard foot (1) by loosening the height adjustment knob (2).
2. Measure from the tip of the blade to the desired distance. Position the straight edge parallel to the blade at that distance.
3. Clamp the straight edge to the table.
4. Recheck your measurements using the work piece to be cut and make sure the straight edge is secure.
5. Position the work piece against the blade and place the blade guard foot against the top surface of the work piece.
6. Secure the blade guard foot in place by tightening the height adjustment knob.
7. Remove the work piece from the blade prior to turning the scroll saw ON.

FIGURE 20

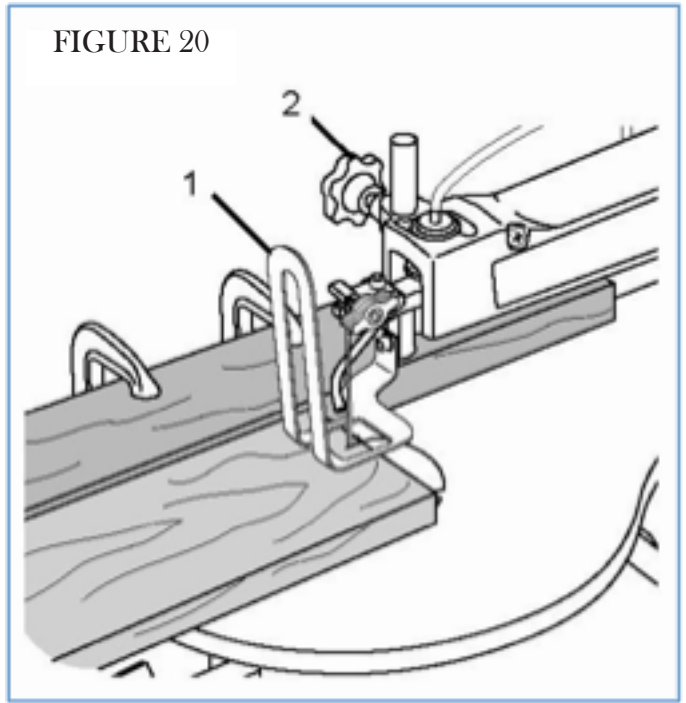

CAUTION: In order to avoid uncontrollable lifting of the work piece and reduce blade breakage, do not turn the switch on while the work piece is against the blade.

8. Position the work piece against the straight edge prior to touching the leading edge of the work piece against the blade.
9. Slowly feed the work piece into the blade, guiding the work piece against the straight edge and pressing the work piece down against the table.

CAUTION: Do not force the leading edge of the work piece into the blade. The blade will deflect, reducing the accuracy of the cut, and may even break.

10. When the cut is complete, move the trailing edge of the work piece beyond the blade guard foot. Turn the switch OFF.

MAINTENANCE

WARNING: Always turn the switch OFF and unplug the power cord from the outlet before maintaining or lubricating the scroll saw.

To ensure that the wood glides smoothly across the work surface, periodically apply a coat of paste wax (sold separately) to the surface of the worktable. If the power cord is worn out or damaged in any way, replace it immediately. Do not attempt to oil the motor bearings or service the motor's internal parts.

LUBRICATION (Fig. 21)

Lubricate the arm bearings after every 50 hours of use.

1. Turn the saw on its side and remove the cover.
2. Squirt a generous amount of SAE 20 oil (lightweight motor oil, sold separately) around the shaft and bearing.
3. Let the oil soak in overnight.
4. Repeat the above procedure for the opposite side of the saw.

FIGURE 21

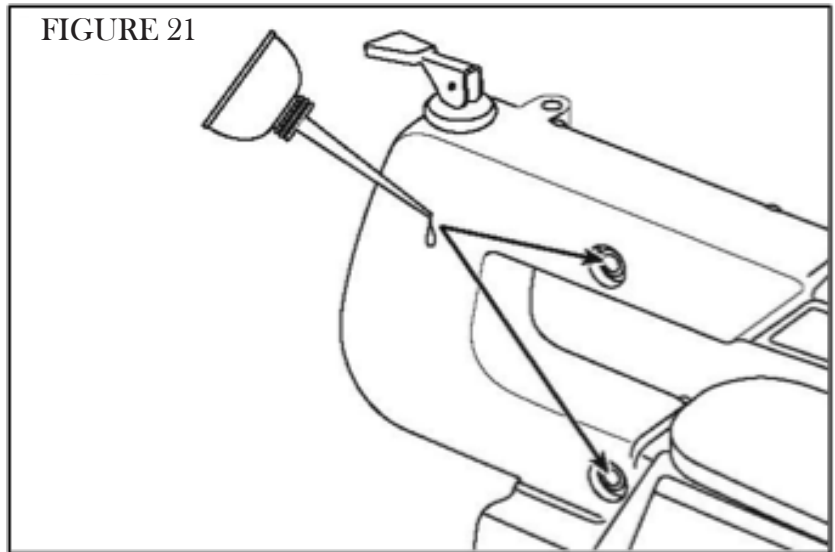

BLADES

To maximize the life of your scroll saw blades:

1. Do not bend blades when installing.
2. Always set proper blade tension.
3. Use the right blade (see instructions on replacement blade packaging for proper use).
4. Feed the work correctly into the blade.
5. Use thin blades for intricate cutting.

CAUTION: Any and all servicing should be performed by a qualified service center.

EXPLODED VIEW & PARTS LIST

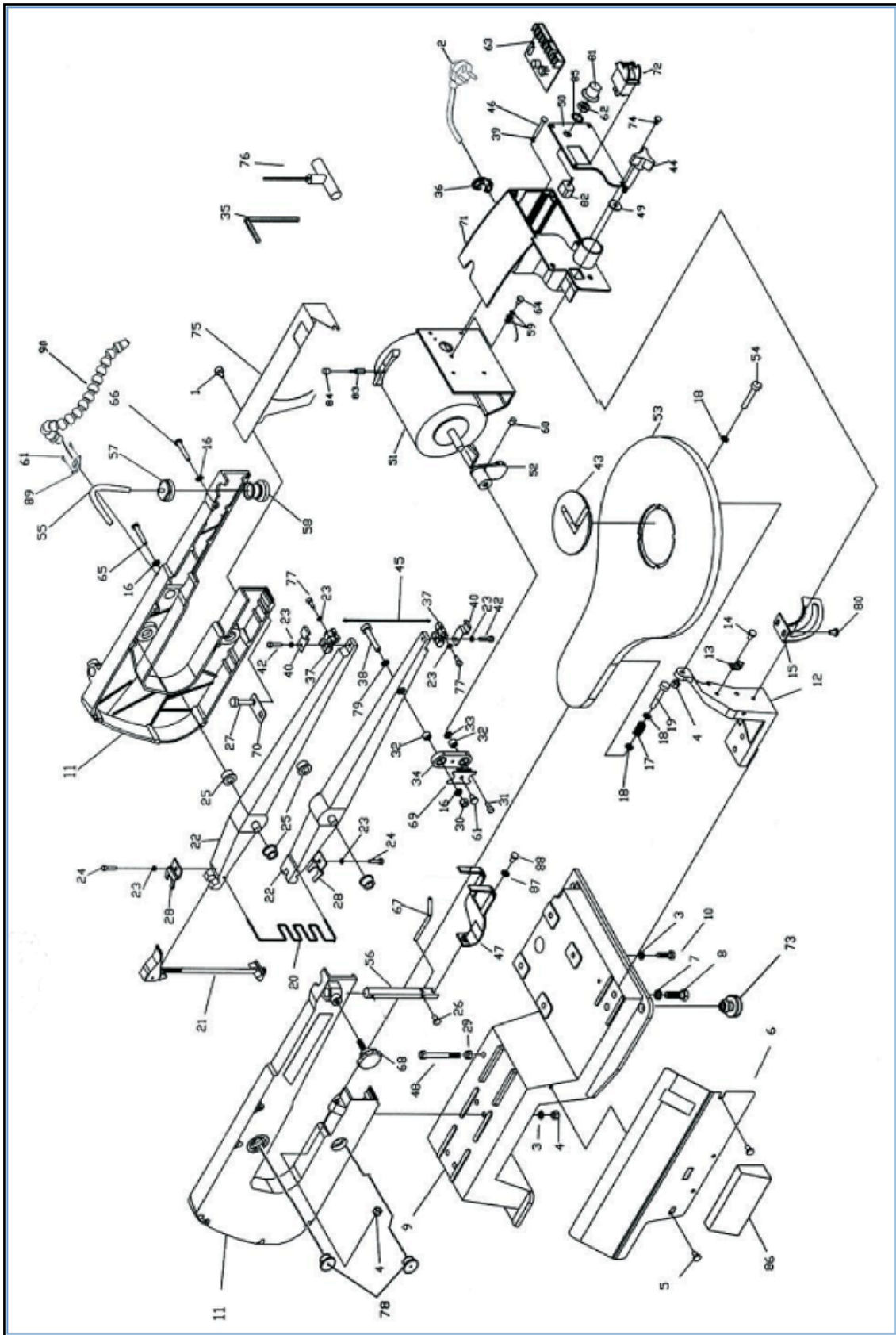

EXPLODED VIEW & PARTS LIST

Item	Stock#	DESCRIPTION	Qty
1	90223-001	SCREW ST4.2X9.5	2
2	90223-002	POWER CORD	1
3	90223-003	SPRING WASHER 6	8
4	90223-004	NUT M6	6
5	90223-005	SCREW M5X10	4
6	90223-006	PLATE COVER	1
7	90223-007	SPRING WASHER 8	2
8	90223-008	SCREW M8X25	2
9	90223-009	BASE	1
10	90223-010	SCREW M6X16	4
11a	90223-011a	HOUSING (LEFT)	1
11b	90223-011b	HOUSING (RIGHT)	1
12	90223-012	SUPPORT TABLE	1
13	90223-013	INDICATOR	1
14	90223-014	SCREW M6X12	1
15	90223-015	BRACKET	1
16	90223-016	SPRING WASHER 5	9
17	90223-017	SPRING	1
18	90223-018	FLAT WASHER 6	4
19	90223-019	BOLT M6X40	1
20	90223-020	SPRING	1
21	90223-021	BOLT TENSION	1
22	90223-022	ROCKER ARM ASSY	2
23	90223-023	SPRING WASHER 4	6
24	90223-024	BOLT M4X10	2
25	90223-025	BEARING FLANGE	4
26	90223-026	SCREW M5X 6	1
27	90223-027	SCREW M6X25	4
28	90223-028	RETAINER	2
29	90223-029	NUT M5	1
30	90223-030	NUT M5	1
31	90223-031	BOLT M5X20	1
32	90223-032	BEARING 625-2Z	2
33	90223-033	WASHER	1
34	90223-034	LINK ASSEMBLY	1
35	90223-035	ALLEN WRENCH 4	1
36	90223-036	CORD CLAMP	1
37	90223-037	BLADE HOLDER	2
38	90223-038	BOLT M5X25	1
39	90223-039	FLAT WASHER 4	4
40	90223-040	PLATE CHIP	2
42	90223-042	BOLT M4X16	2
43	90223-043	TABLE INSERT	1
44	90223-044	KNOB	1
45	90223-045	BLADE	1

Item	Stock#	DESCRIPTION	Qty
46	90223-046	SCREW M4X16	4
47	90223-047	HOLDER PLATE	1
48	90223-048	LOCALIZER	1
49	90223-049	WASHER 6	1
50	90223-050	SWITCH COVER	1
51	90223-051	MOTOR	1
52	90223-052	ECCENTRIC	1
53	90223-053	TABLE	1
54	90223-054	BOLT M6X35	1
55	90223-055	HOSE	1
56	90223-056	SUPPORT ROD	1
57	90223-057	AIR BAG SEAL	1
58	90223-058	AIR BAG	1
59	90223-059	WASHER 4	2
60	90223-060	SCREW M8X8	1
61	90223-061	SCREW ST4.2X8	6
62	90223-062	NUT M10	1
63	90223-063	PCB	1
64	90223-064	SCREW M4X8	1
65	90223-065	SCREW M5X35	5
66	90223-066	SCREW M5X30	3
67	90223-067	BLOWER TUBE	1
68	90223-068	KNOB	1
69	90223-069	BEARING FENCE	1
70	90223-070	SET PLATE	1
71	90223-071	SWITCH CASE	1
72	90223-072	POWER SWITCH	1
73	90223-073	RUBBER FOOT	4
74	90223-074	SCREW ST4.2X13	6
75	90223-075	BACK PLATE COVER	1
76	90223-076	WRENCH	1
77	90223-077	SCREW M4X20	2
78	90223-078	BEARING COVER	4
79	90223-079	WASHER 5	1
80	90223-080	SCREW M5X8	5
81	90223-081	SPEED KNOB	1
82	90223-082	SPEED CONTROLLER	1
83	90223-083	CARBON BRUSH	2
84	90223-084	BRUSH CAP	2
85	90223-085	WASHER M10	1
86	90223-086	BLADE STORAGE	1
87	90223-087	WASHER M5	1
88	90223-088	BOLT M5x10	1
89	90223-089	LIGHT BASE	1
90	90223-090	LIGHT ASSEMBLY	1

LIMITED TWO YEAR WARRANTY

WEN Products is committed to building tools that are dependable for years. Our warranties are consistent with this commitment and our dedication to quality.

LIMITED WARRANTY OF WEN CONSUMER POWER TOOLS PRODUCTS FOR HOME USE

GREAT LAKES TECHNOLOGIES, LLC (“Seller”) warrants to the original purchaser only, that all WEN consumer power tools will be free from defects in material or workmanship for a period of two (2) years from date of purchase. Ninety days for all WEN products, if the tool is used for professional use.

SELLER’S SOLE OBLIGATION AND YOUR EXCLUSIVE REMEDY under this Limited Warranty and, to the extent permitted by law, any warranty or condition implied by law, shall be the repair or replacement of parts, without charge, which are defective in material or workmanship and which have not been misused, carelessly handled, or misrepaired by persons other than Seller or Authorized Service Center. To make a claim under this Limited Warranty, you must return the complete power tool product; transportation prepaid, to Great Lakes Technologies, LLC - 1675 Holmes Road - Elgin, IL. 60123 with a copy of the original receipt which is legible and clearly defines Date of Purchase including month and year and Place of Purchase.

THIS LIMITED WARRANTY DOES NOT APPLY TO ACCESSORY ITEMS SUCH AS CIRCULAR SAW BLADES, DRILL BITS, ROUTER BITS, JIGSAW BLADES, SANDING BELTS, GRINDING WHEELS AND OTHER RELATED ITEMS.

ANY IMPLIED WARRANTIES SHALL BE LIMITED IN DURATION TO TWO (2) YEARS FROM DATE OF PURCHASE. SOME STATES IN THE U.S., SOME CANADIAN PROVINCES DO NOT ALLOW LIMITATIONS ON HOW LONG AN IMPLIED WARRANTY LASTS, SO THE ABOVE LIMITATION MAY NOT APPLY TO YOU.

IN NO EVENT SHALL SELLER BE LIABLE FOR ANY INCIDENTAL OR CONSEQUENTIAL DAMAGES (INCLUDING BUT NOT LIMITED TO LIABILITY FOR LOSS OF PROFITS) ARISING FROM THE SALE OR USE OF THIS PRODUCT. SOME STATES IN THE U.S. AND SOME CANADIAN PROVINCES DO NOT ALLOW THE EXCLUSION OR LIMITATION OF INCIDENTAL OR CONSEQUENTIAL DAMAGES, SO THE ABOVE LIMITATION OR EXCLUSION MAY NOT APPLY TO YOU.

THIS LIMITED WARRANTY GIVES YOU SPECIFIC LEGAL RIGHTS, AND YOU MAY ALSO HAVE OTHER RIGHTS WHICH VARY FROM STATE TO STATE IN THE U.S., PROVINCE TO PROVINCE IN CANADA AND FROM COUNTRY TO COUNTRY.

THIS LIMITED WARRANTY APPLIES ONLY TO PORTABLE ELECTRIC TOOLS, BENCH POWER TOOLS, OUTDOOR POWER EQUIPMENT AND PNEUMATIC TOOLS SOLD WITHIN THE UNITED STATES OF AMERICA, CANADA AND THE COMMONWEALTH OF PUERTO RICO. FOR WARRANTY COVERAGE WITHIN OTHER COUNTRIES, CONTACT THE WEN CUSTOMER SUPPORT LINE.