

OWNER'S MANUAL



Grand Champ™

Model 8100

Keep your receipt with this manual for Warranty.

**CUSTOMER SERVICE
1-912-638-4724
Service@CharGriller.com**

Contents of this manual are Trademarked and Copyrighted by Char-Griller | A&J Manufacturing.

Using the information contained in this manual without consent of Char-Griller and/or

A&J Manufacturing is strictly prohibited.



STOP! CALL  FIRST!

DO NOT RETURN PRODUCT TO STORE.

CALL (912) 638-4724 or email us at: Service@Char-Griller.com. This product has been built to the highest quality standards.

Call us should you have any questions not addressed in these instructions, or for service information.

Have your grill's serial number ready (located on the back of the grill body or on the leg) when calling.

PROPOSITION 65 WARNING:

WARNING: This product and combustion by-products produced when using this product contain chemicals known to the State of California to cause cancer, birth defects, or other reproductive harm.

IMPORTANT SAFETY WARNINGS

READ ALL SAFETY WARNINGS AND INSTRUCTIONS CAREFULLY BEFORE
ASSEMBLING AND OPERATING YOUR GRILL

Read the following instructions carefully and be sure your appliance is properly assembled, installed, and maintained. Failure to follow these instructions may result in serious bodily injury and/or property damage. If you have any questions concerning assembly or operation, consult your dealer.

- Grill is for outdoor use only.
- Use caution when assembling and operating your grill to avoid scrapes or cuts from sharp edges.
- Do not use gasoline, kerosene, or alcohol for lighting charcoal. Use of any of these or similar products could cause an explosion possibly leading to severe bodily injury.
- Do not leave a lit grill unattended. Keep children and pets away from grill at all times.
- Use caution when moving grill to prevent strains.
- Keep grill at least 15 feet from any combustible material (decks, buildings, fences, trees, bushes, etc).
- When adding charcoal and/or wood, use extreme caution.
- Never move grill when it is in use or when it contains hot coals or ashes.
- Do not place grill near flammable liquids, gases, or where flammable vapors may be present.
- Use caution since flames can flare-up when fresh air suddenly comes in contact with fire.
- When opening the lid, keep hands, face, and body safe from hot steam and flame flare-ups.
- **WARNING:** To avoid injuries, gloves, or other protective articles should be used when touching the ash pan hangers.
- Do not exceed a temperature of 400°F.
- Do not allow charcoal and/ or wood to rest on the walls of grill. Doing so will greatly reduce the life of the grill.
- Always wear oven mitts to protect hands from burns. Avoid touching hot surfaces.
- When opening lid, make sure it is pushed all the way back so it rests against the lid support brackets. Use extreme caution as hood could fall back to a closed position and cause bodily injury.
- Close lid and all dampers to help suffocate flame.
- Always hold an open lid from the handle to prevent it from closing unexpectedly.

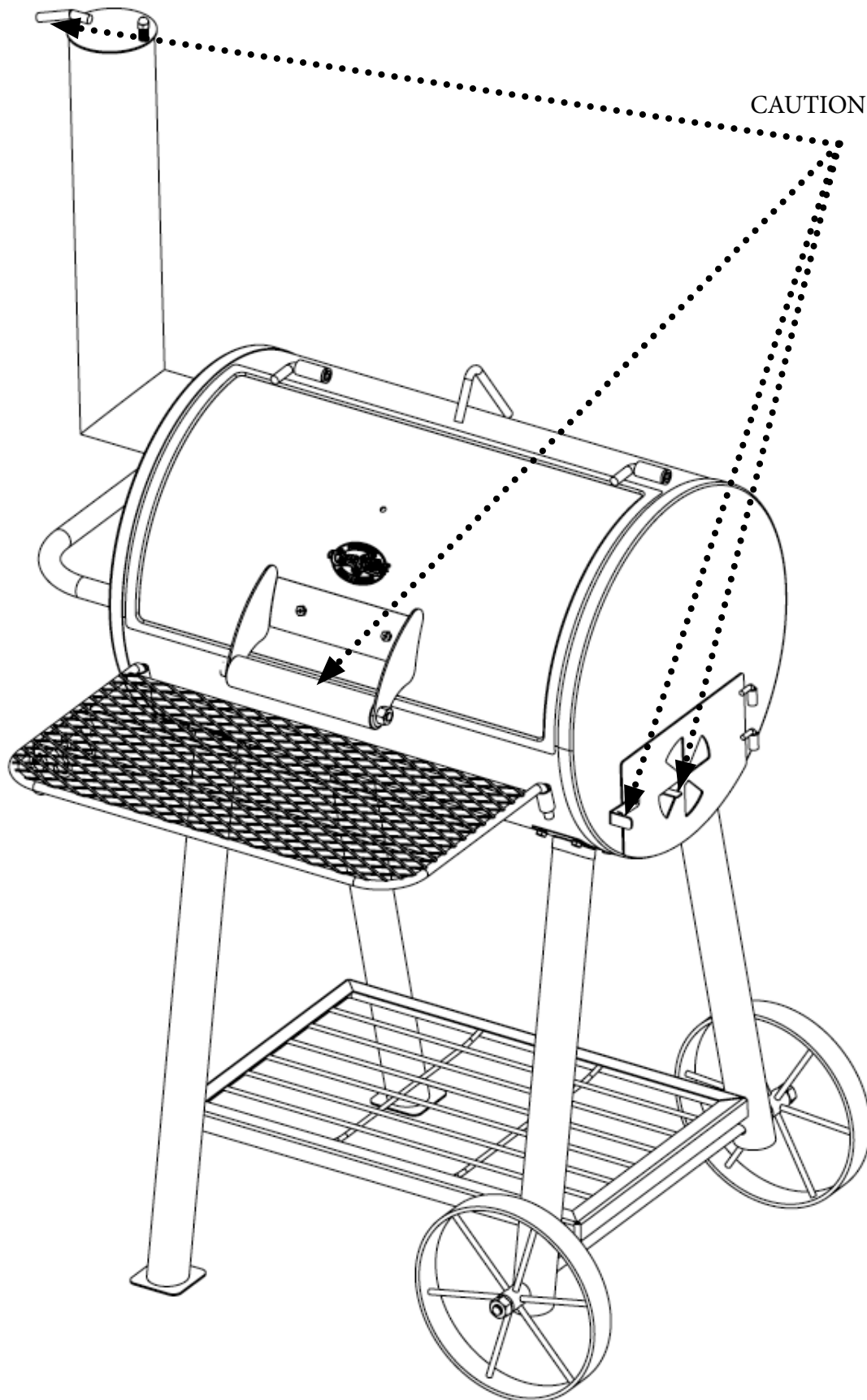

CAUTION: Handles are Hot

- Never leave coals and ashes unattended. Before grill can be left unattended, coals and ashes must be removed. Use caution to protect yourself and property.
- Carefully place remaining coals and ashes in a noncombustible metal container and saturate completely with water. Allow coals and water to remain in metal container 24 hours prior to disposing.
- To protect against bacteria that could cause illness, keep all meats refrigerated and thaw in refrigerator or microwave. Keep raw meats separate from other foods, and wash everything that comes in contact with raw meat.
- Cook meat thoroughly, and refrigerate leftovers immediately.
- Cook meats medium to well done.

THESE WARNINGS ALSO APPLY TO THE SIDE FIRE BOX.

Stop! Call us first! Do Not return product to store. This grill has been made according to the highest of quality standards. If you have any questions not addressed in this manual or if you need parts please call our customer service department at 1-912-638-4724 (USA), Monday-Friday 8:30 am-5 pm (EST) or email Char-Griller at: Service@CharGriller.com.

Have your grill's serial number (located on the back of the grill body or on the leg) when calling.

IMPORTANT NOTICE: Read all instructions prior to assembly and use. Read and understand all warnings and precautions prior to operating your grill.



WARRANTY INFORMATION

CHAR-GRILLER® CHARCOAL GRILL

Char-Griller® will repair or replace any defective part of its Grills for a period of up to one (1) year from the date of purchase.

Char-Griller® will also repair or replace the charcoal grill body (lid and bottom half) and gas grill lid of its grillers/smokers if the metal is rusted through or burned through for a period up to five (5) years from date of purchase.

Char-Griller® will repair or replace the gas grill body if the metal is rusted through or burned through for a period up to one (1) year from date of purchase.

Char-Griller® gas grill burners have a five (5) year warranty from the date of purchase.

Proof of purchase, proof of purchase date and prepaid return of the item in question may be required. Misuse, abuse, or commercial use nullifies all warranties. Paint/finish is not warranted. Products are not warranted against rust.

The warranty is for replacement of defective parts only. Manufacture will not be responsible for damage resulting from accident, alteration, misuse, abuse, hostile environments, improper installation, installation not in accordance with local codes of service of unit.

This limited warranty does not cover any scratches, dents, corrosion or discoloring by heat, abrasive and chemical cleaners nor any components used in the installation of the appliance.

Save your receipt for all warranty claims.

PARTS LIST

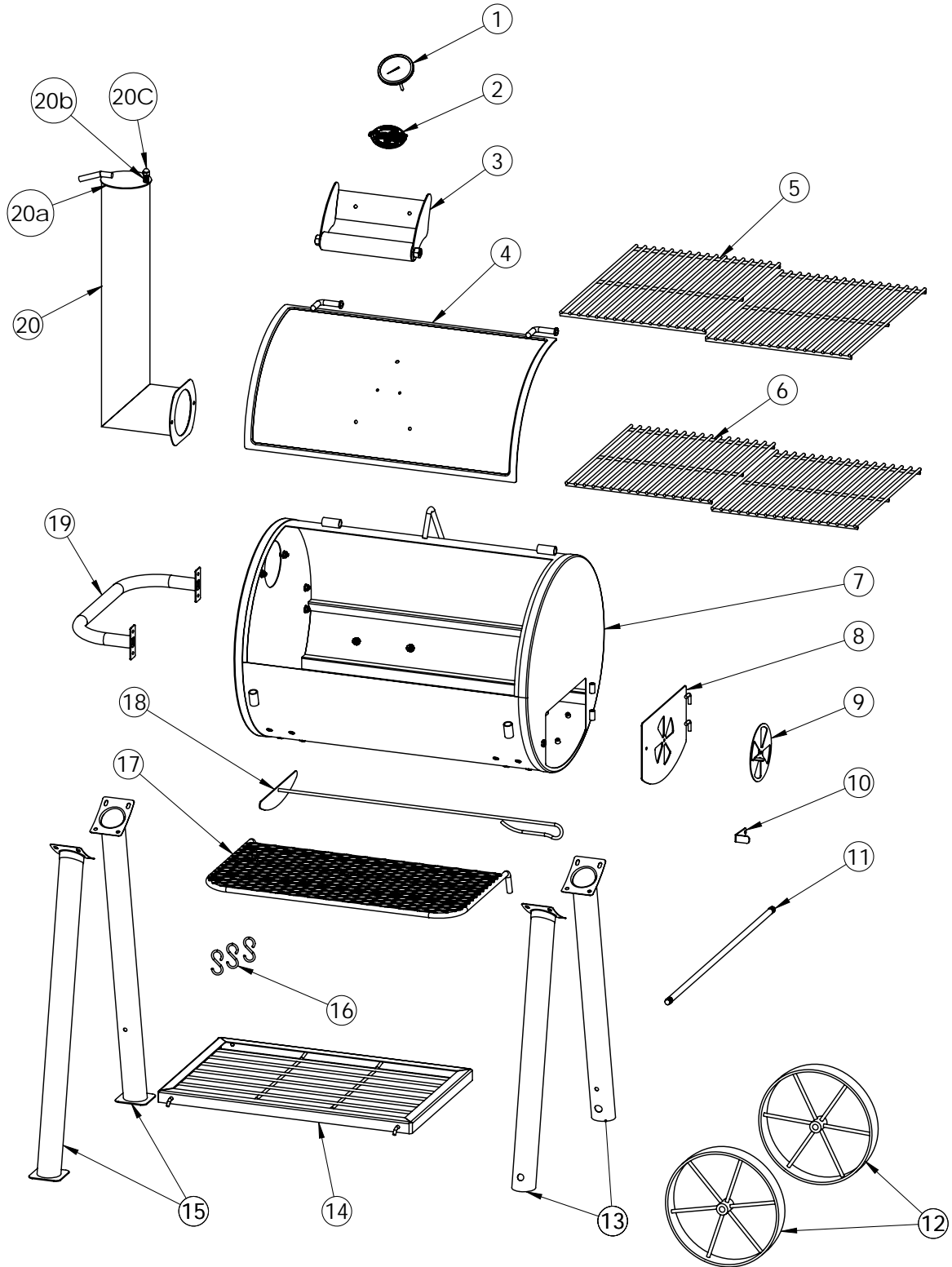



PARTS LIST

Item	QTY	Part Name
1	1	THERMOMETER WITH WING NUT & FLAT WASHER
2	1	LOGO PLATE WITH CLIPS
3	1	HOOD HANDLE
4	1	LID
5	2	COOKING GRATE
6	2	CHARCOAL GRATE
7	1	BODY
8	1	SIDE DOOR
9	1	DAMPER CIRCLE
10	1	DOOR LATCH
11	1	AXLE ROD
12	2	METAL WHEEL
13	2	SHORT LEG
14	1	BOTTOM SHELF
15	2	LONG LEG
16	3	UTENSIL HOOK
17	1	FRONT SHELF
18	1	ASH SCAPPER
19	1	SIDE HANDLE
20	1	SMOKESTACK ASSEMBLY
20a	1	SMOKESTACK DAMPER
20b	1	SMOKESTACK SPRING
20c	1	AKORN NUT

HARDWARE AND TOOLS NEEDED

Assembly: Requires 2 people. Get another person to help. Tools Needed: Pliers, Phillips Head Screwdriver and a 7/16" Nut Driver.

NOTE: Do Not tighten any bolts unless instructed to do so. Tightening too soon may prohibit parts from fitting together. All Hex Nuts should be on the inside of the grill unless stated otherwise. Unpack all contents in a well cleared and padded area.

Estimated Assembly Time: 45 minutes

STOP! Do Not Return to Store. If you are missing parts or need assistance please email us at Service@CharGriller.com or call 912-638-4724. Do not attempt to assemble or use if you are missing parts.

Hardware Pack: 551059

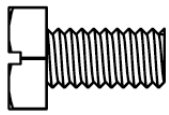
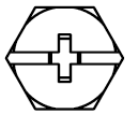

1/4-20 x 1/2" Hex Bolt.....26 Pcs

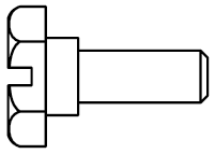

1/4-20 Hex Shoulder Bolt.....1 Pc



1/4-20 Hex Nut.....27 Pcs

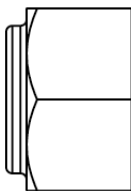
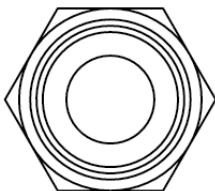

7/16 Hex Jam Nut.....2 Pcs

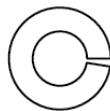

1/4 Lock Washer.....16 Pcs



Utensil Hook.....3 Pcs



ASSEMBLY INSTRUCTIONS

Read all safety warnings and instructions carefully before

assembling and operating your grill.

IMPORTANT HINT: DO NOT TIGHTEN ANY NUTS AND BOLTS UNTIL GRILL IS FULLY ASSEMBLED.

Step 1

Attach one (1) LONG LEG and one (1) SHORT LEG to back leg positions on GRILL BODY underside, using eight (8) 1/4-20 x 1/2" HEX BOLTS, eight (8) 1/4 LOCK WASHERS, and eight (8) 1/4-20 Hex Flange Nuts.

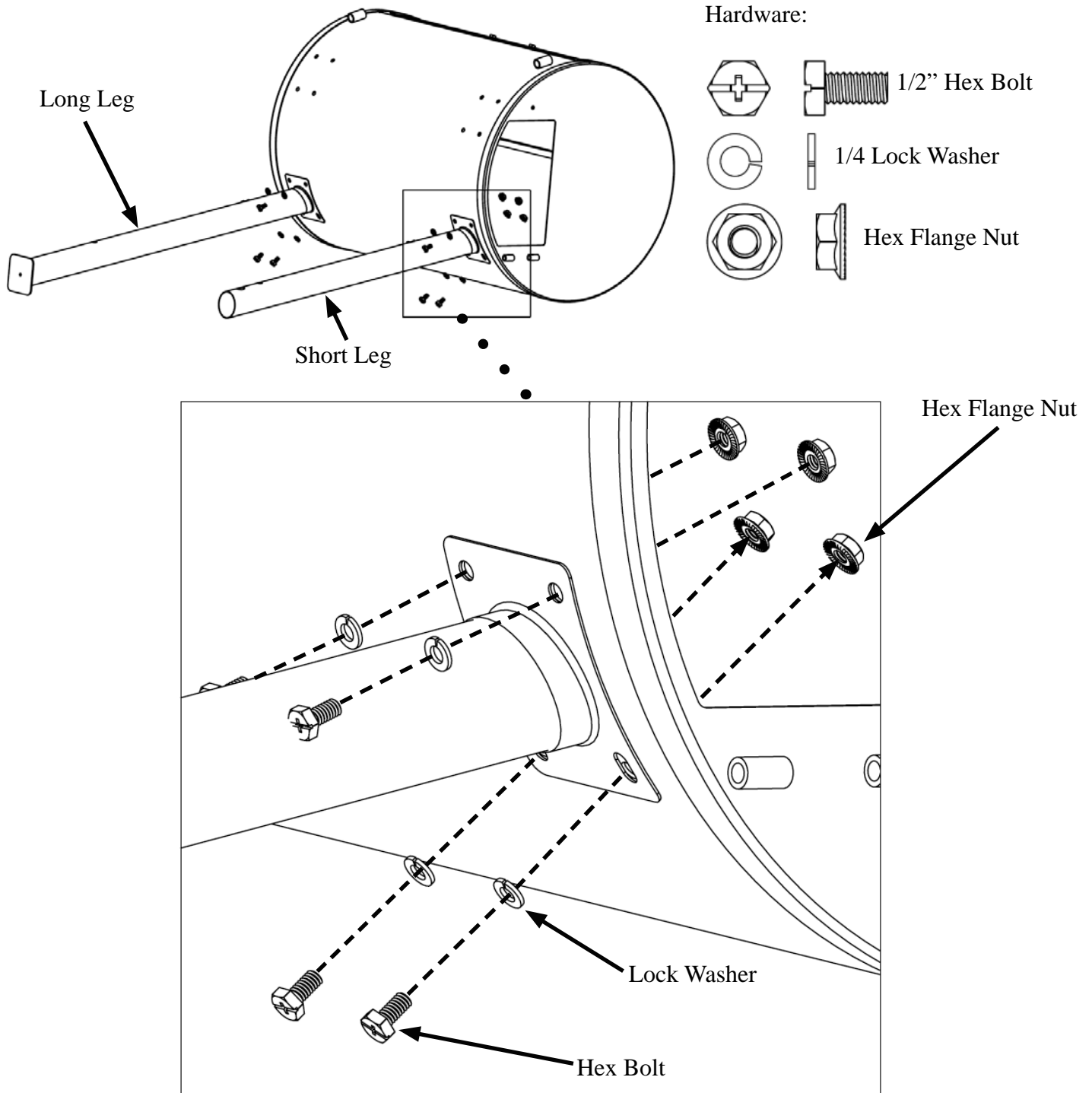

Step 2

Attach other one (1) LONG LEG and one (1) SHORT LEG to front positions on GRILL BODY underside, using eight (8) 1/4-20 x 1/2" HEX BOLTS, eight (8) 1/4 LOCK WASHERS, and eight (8) Hex Flange Nuts. Then, affix BOTTOM SHELF as shown.

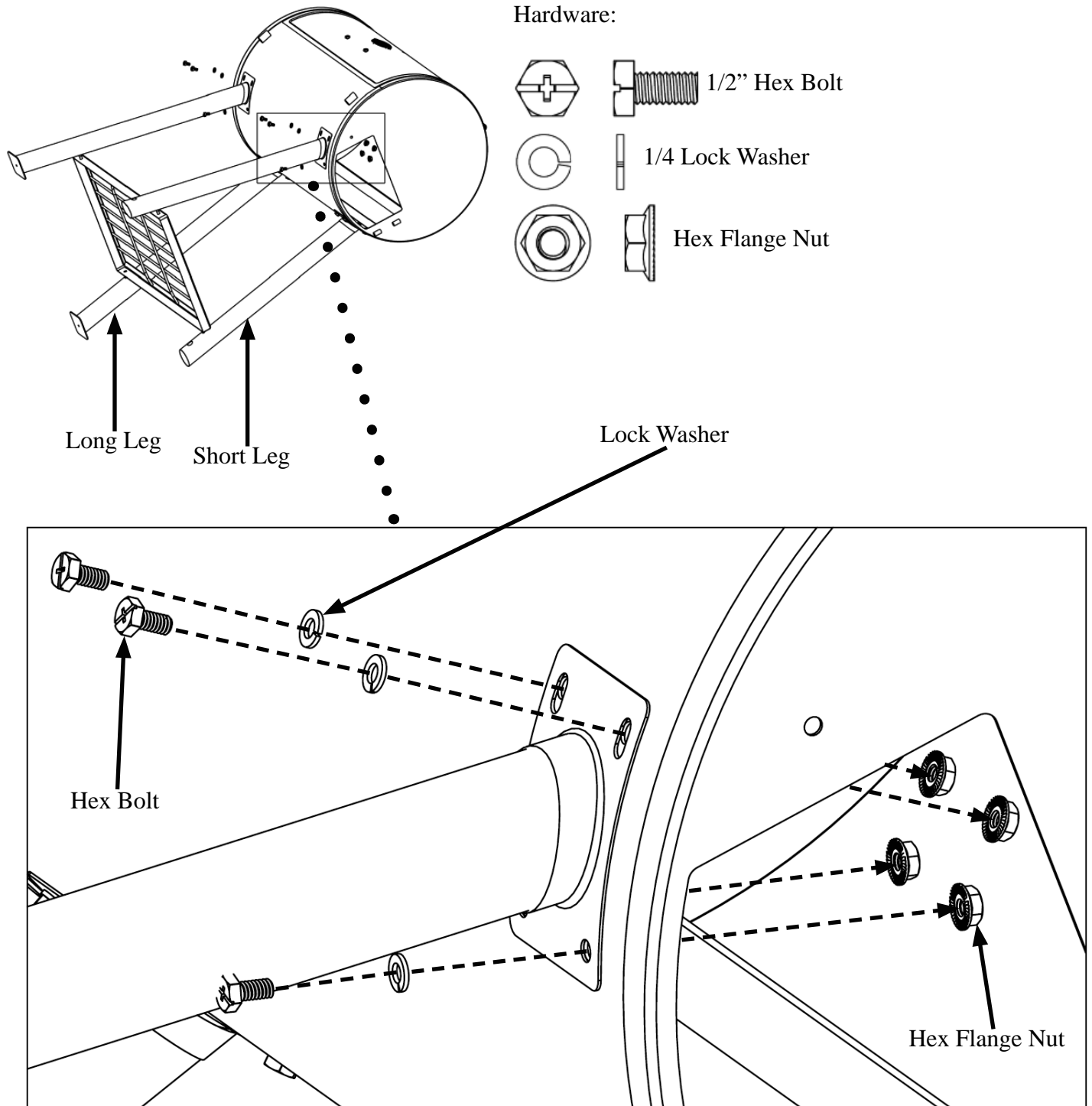



Step 3

RUN AXLE ROD THROUGH HOLES IN SHORT LEGS, THEN ATTACH WHEELS TO AXLE ROD USING TWO (2) 7/16 HEX BOLTS.

Hardware:



7/16 Hex Jam Nut

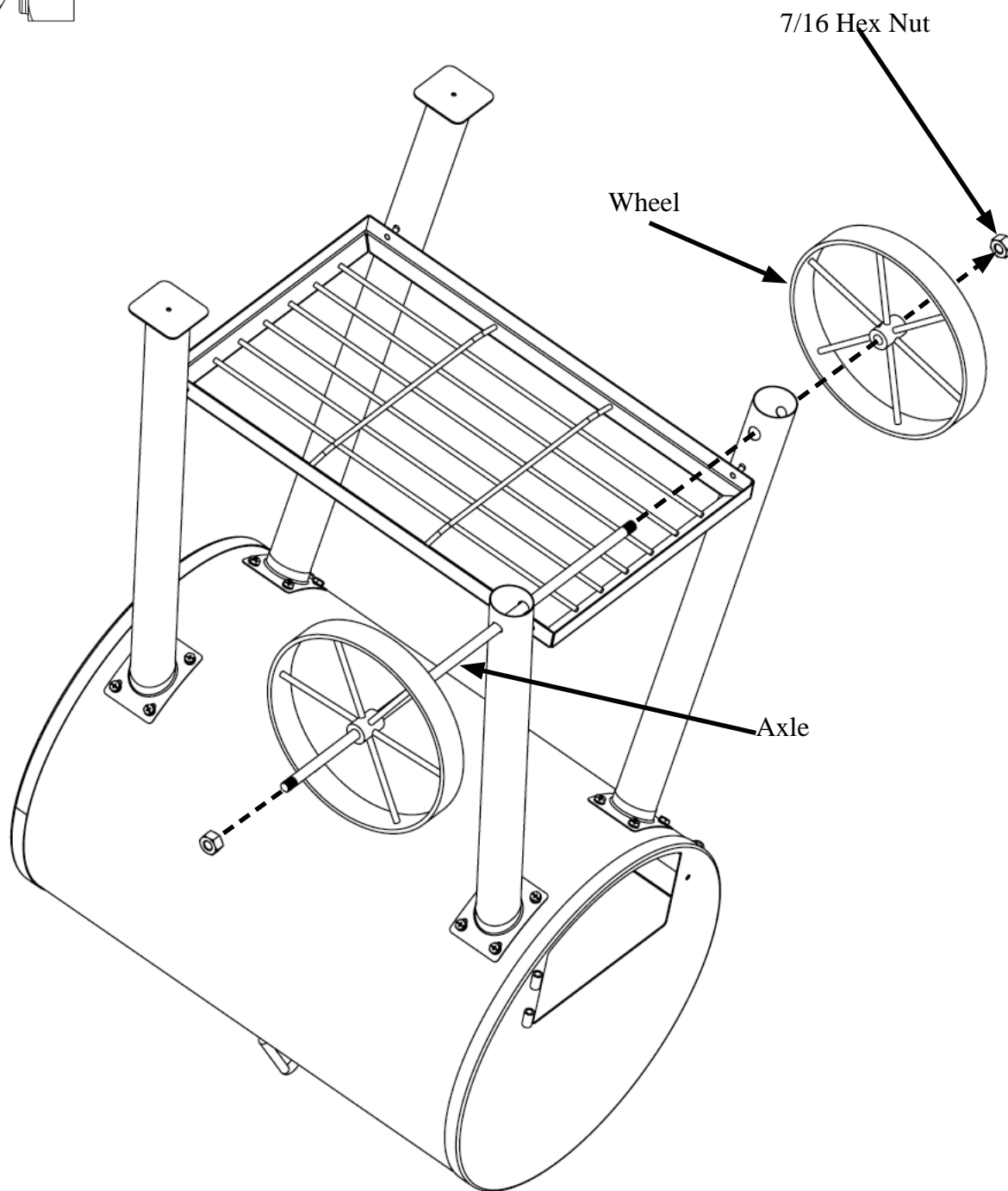

Step 4

Attach HOOD HANDLE to GRILL HOOD using two (2) ¼-20 x ½" HEX BOLTS and two (2) ¼-20 HEX NUTS.

Hardware:

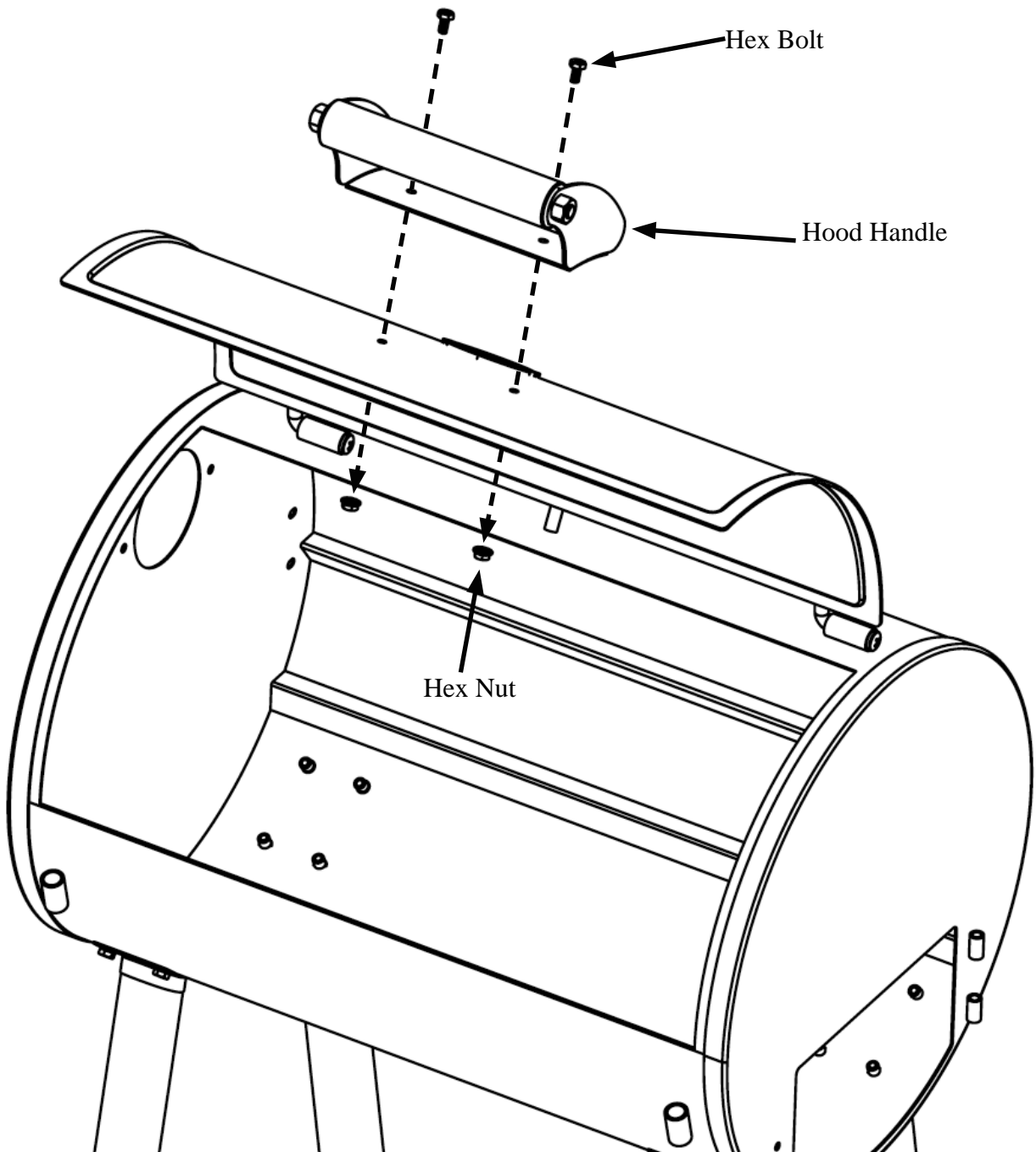
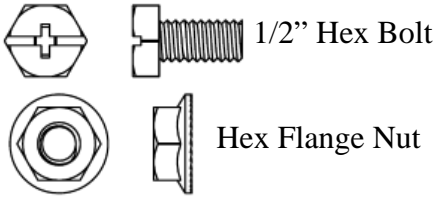



Step 5

Place THERMOMETER through hole in GRILL HOOD, and secure with included WINGNUT and FLAT WASHER, as shown. (NOTE: Hardware came attach on THERMOMETER.)

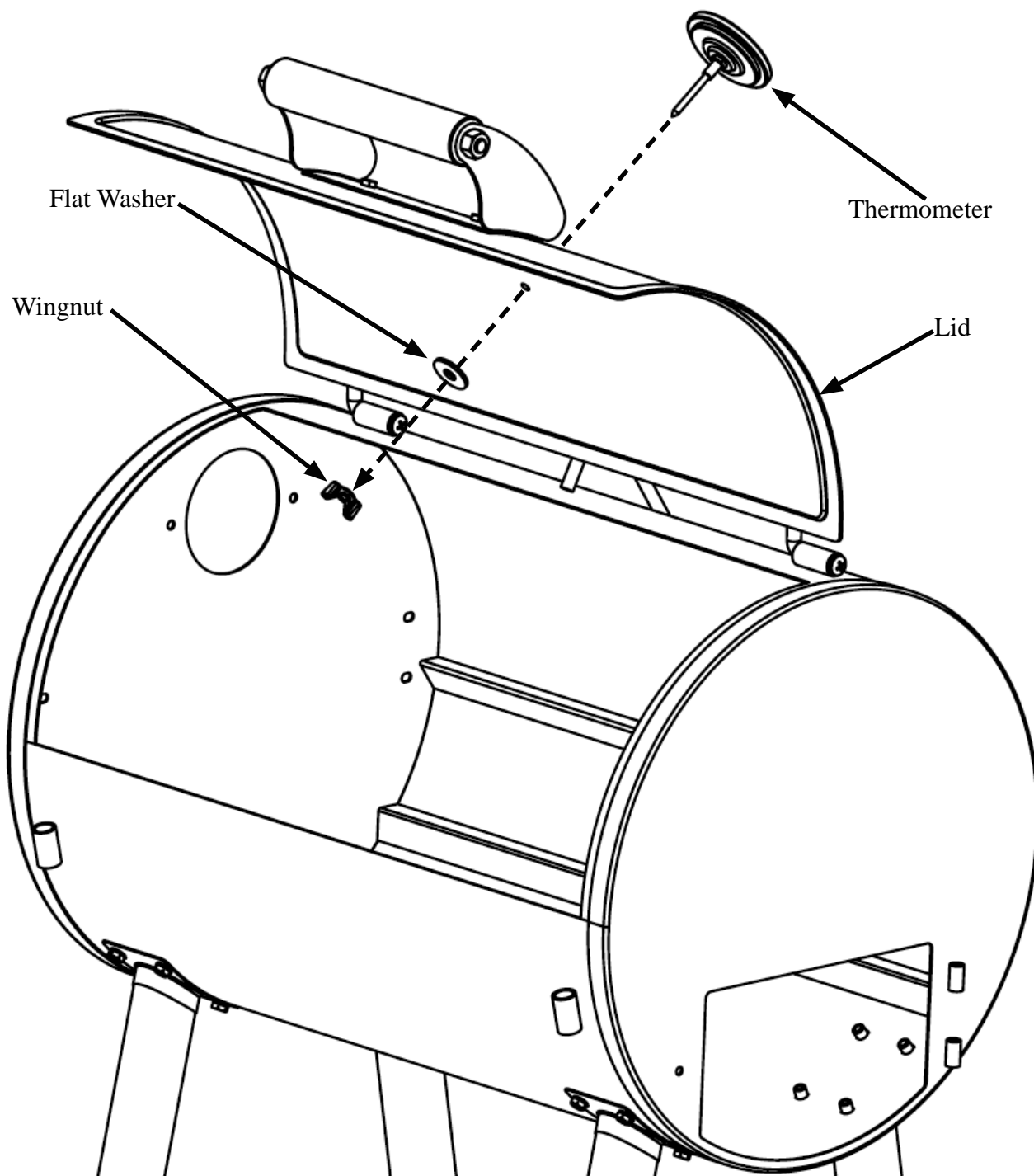

Step 6

Attach SIDE HANDLE to GRILL BODY using four (4) ¼-20 x ½" HEX BOLTS and four (4) ¼-20 HEX FLANGE NUTS.

Hardware:

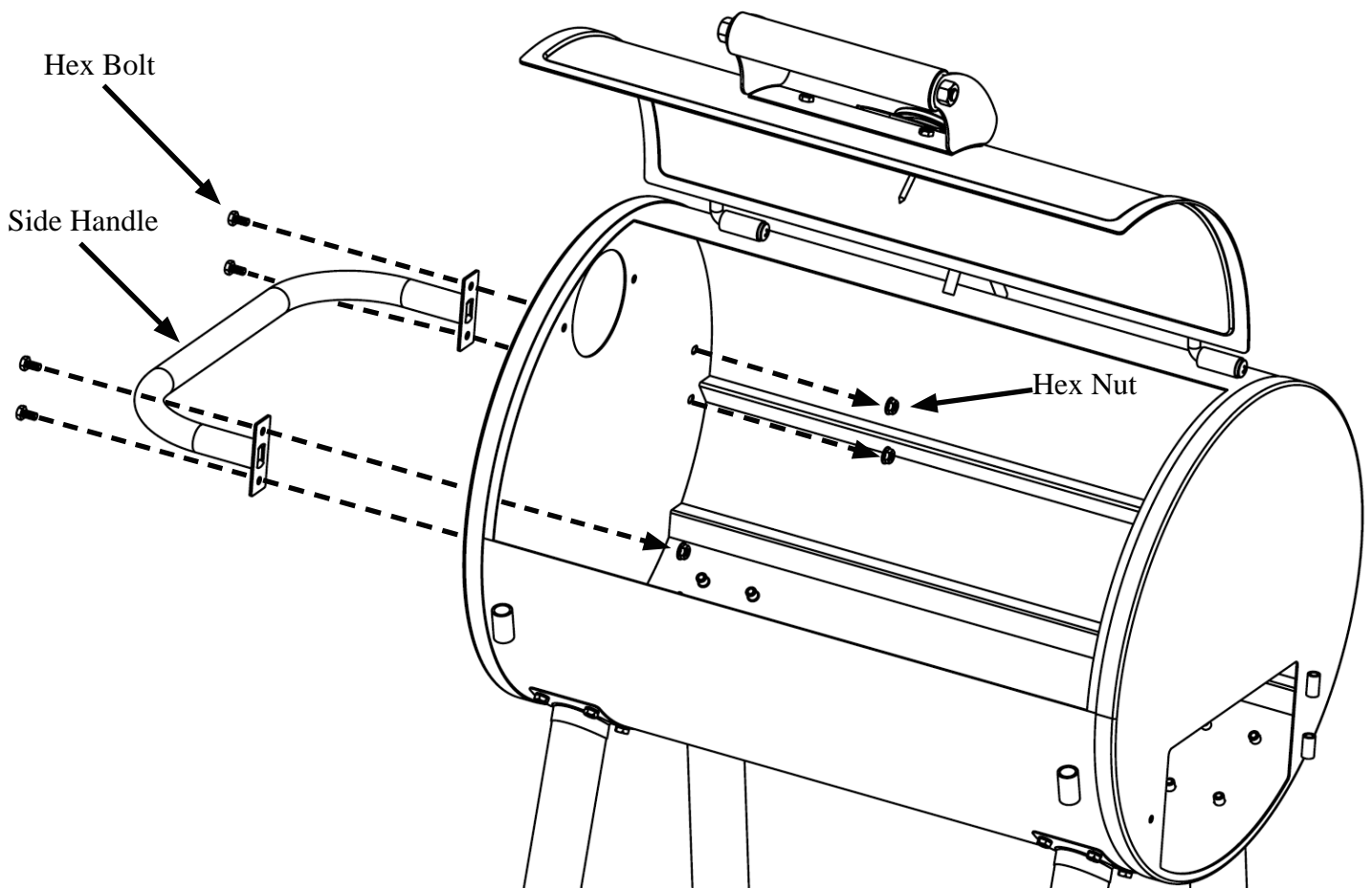
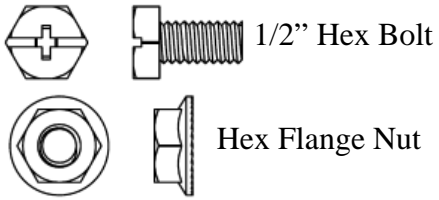



Step 7

Attach SMOKESTACK to GRILL BODY using four (4) 1/4-20 x 1/2" HEX BOLTS and four (4) 1/4-20 HEX FLANGE NUTS.

Hardware:

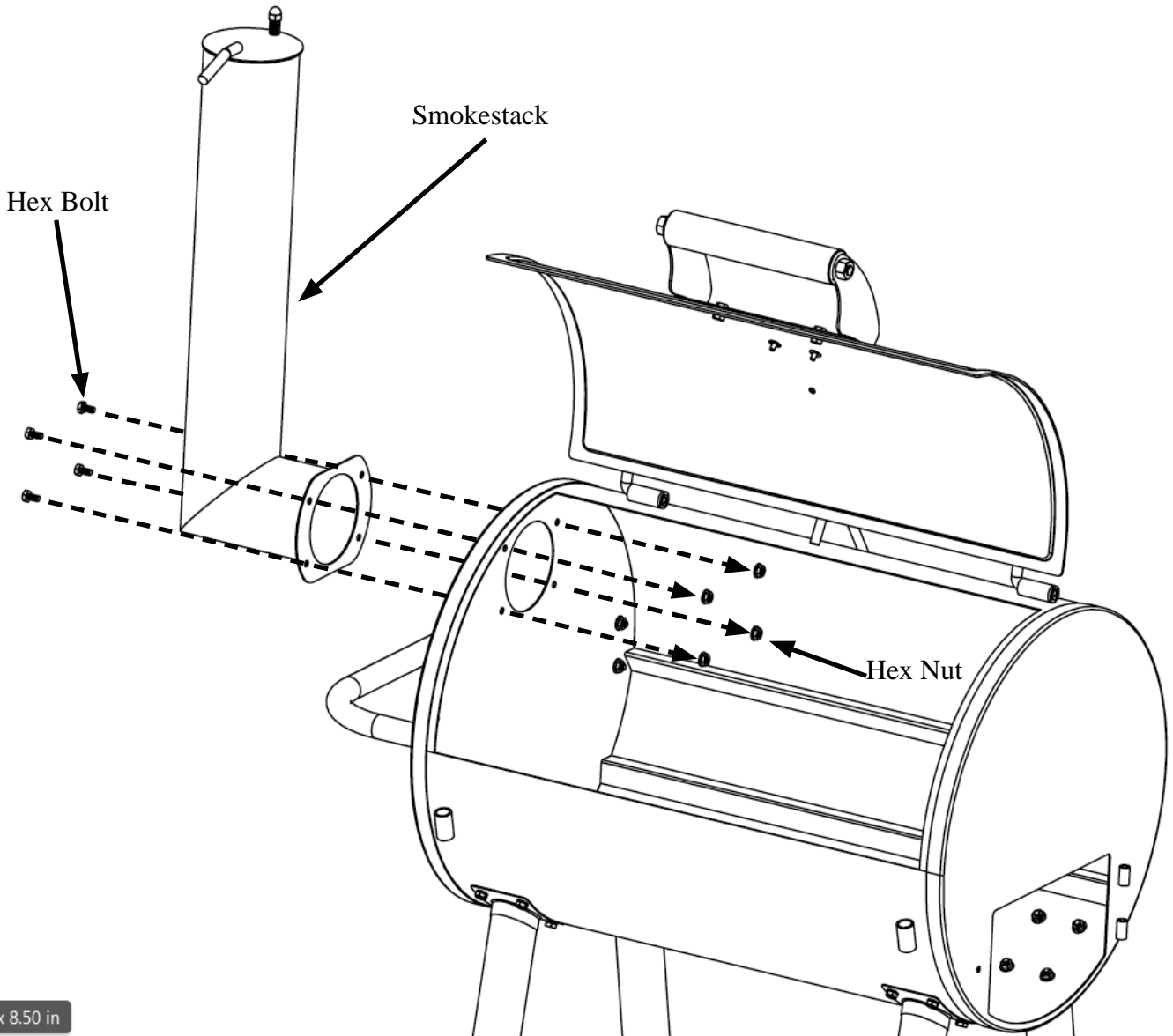
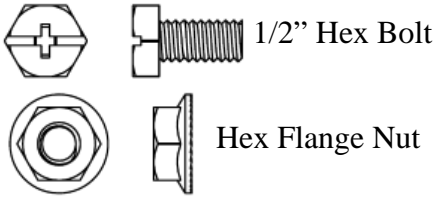

Step 8

Attach SIDE DOOR to side of GRILL BODY using one (1) ¼-20 x ½" SHOULDER BOLT and one (1) ¼-20 HEX FLANGE NUT.

Hardware:

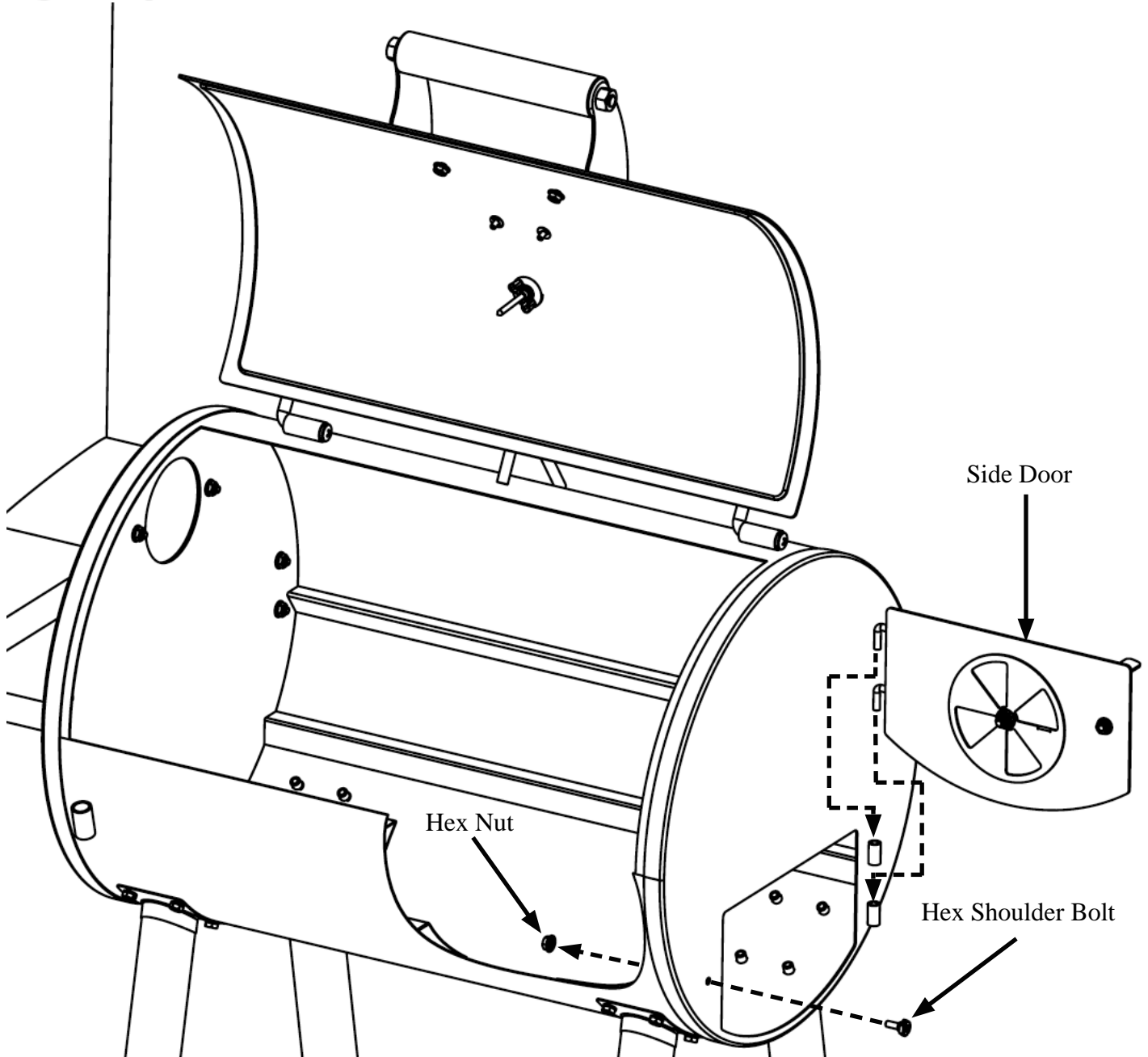
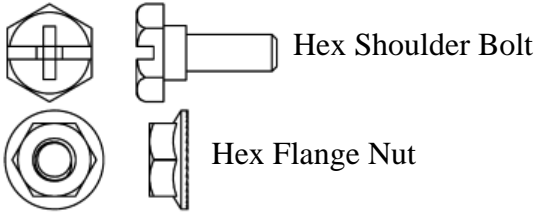

Step 9

Place CHARCOAL GRATES inside GRILL BODY on charcoal grate support, as shown.

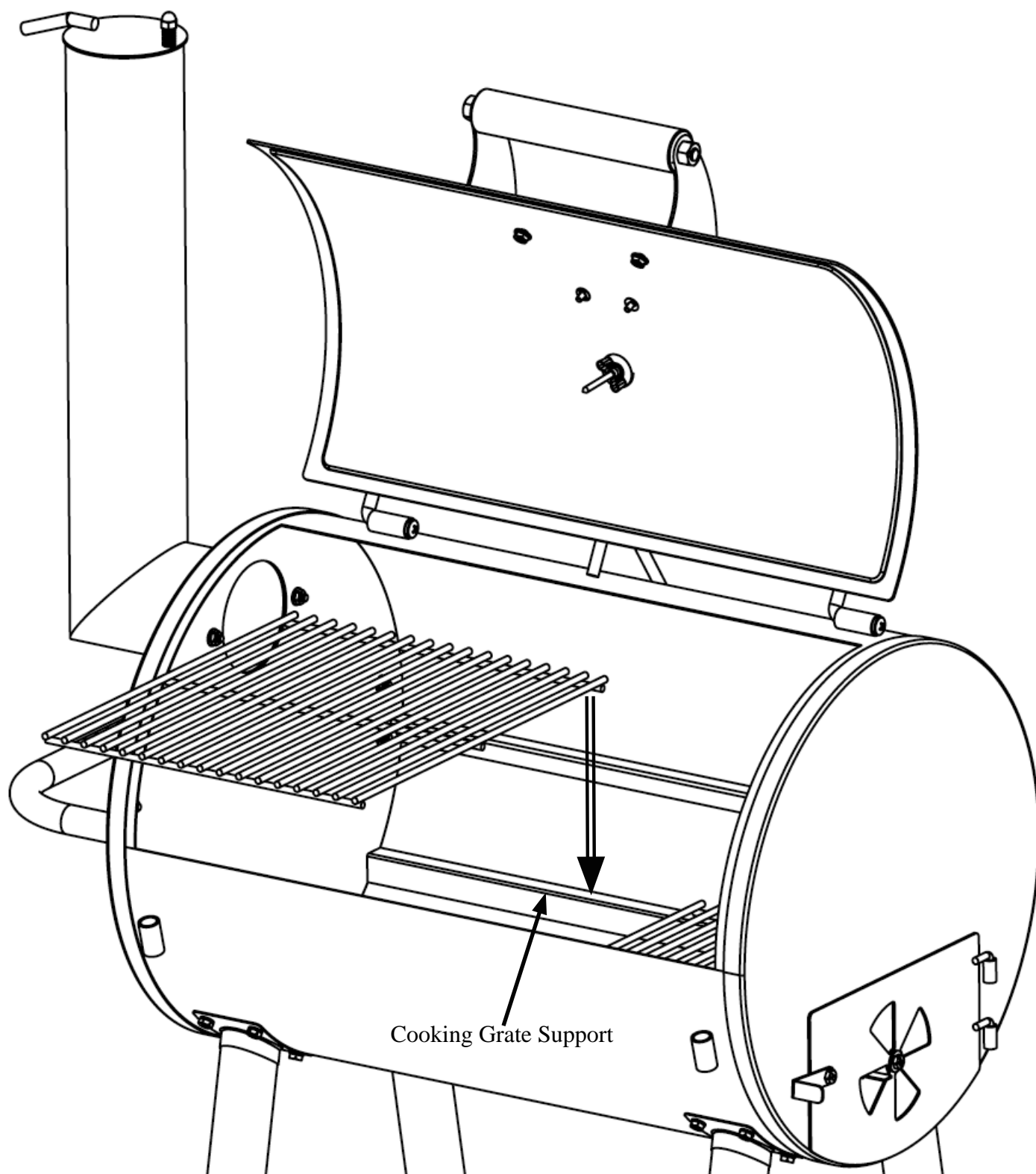

Step 10

Place COOKING GRATES inside GRILL BODY on cooking grate support, as shown.

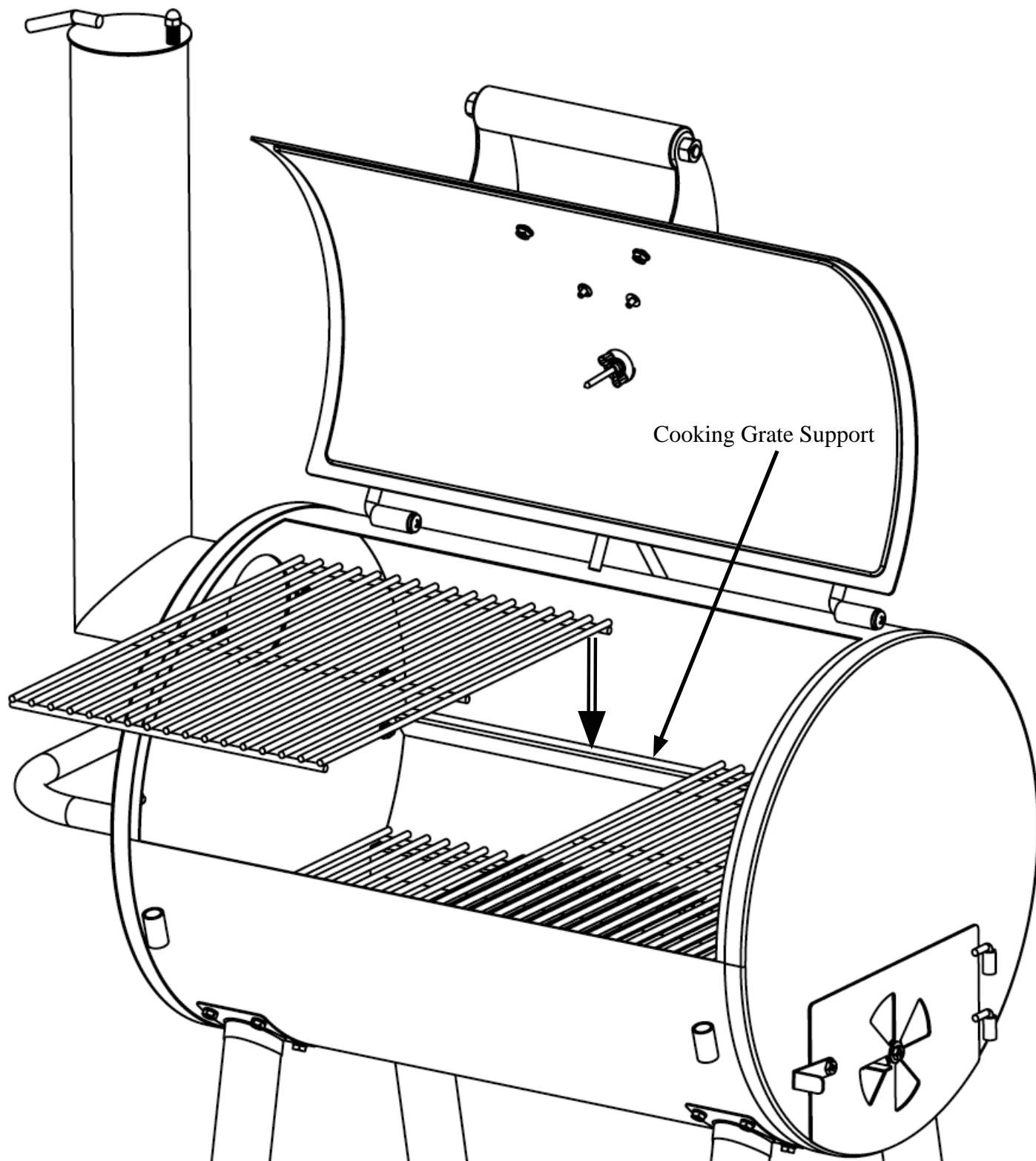

Step 11

Attach FRONT SHELF to front of GRILL BODY, as shown.

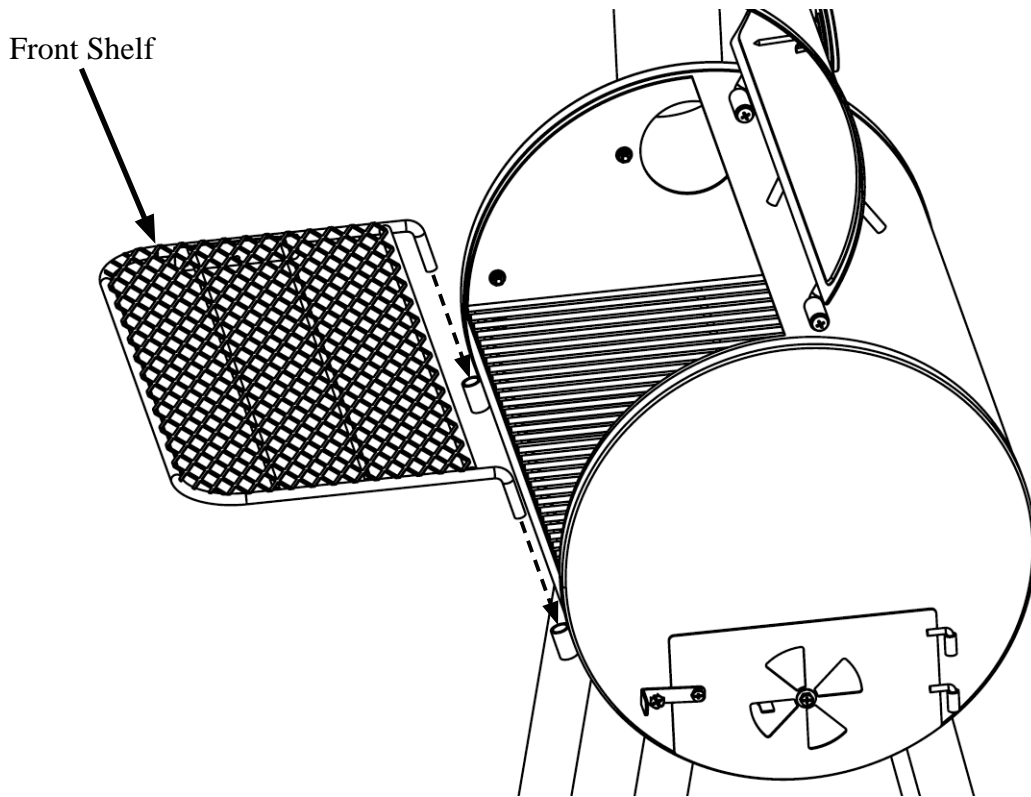

Step 12

Attach UTENSIL HOOKS to FRONT SHELF, as shown.

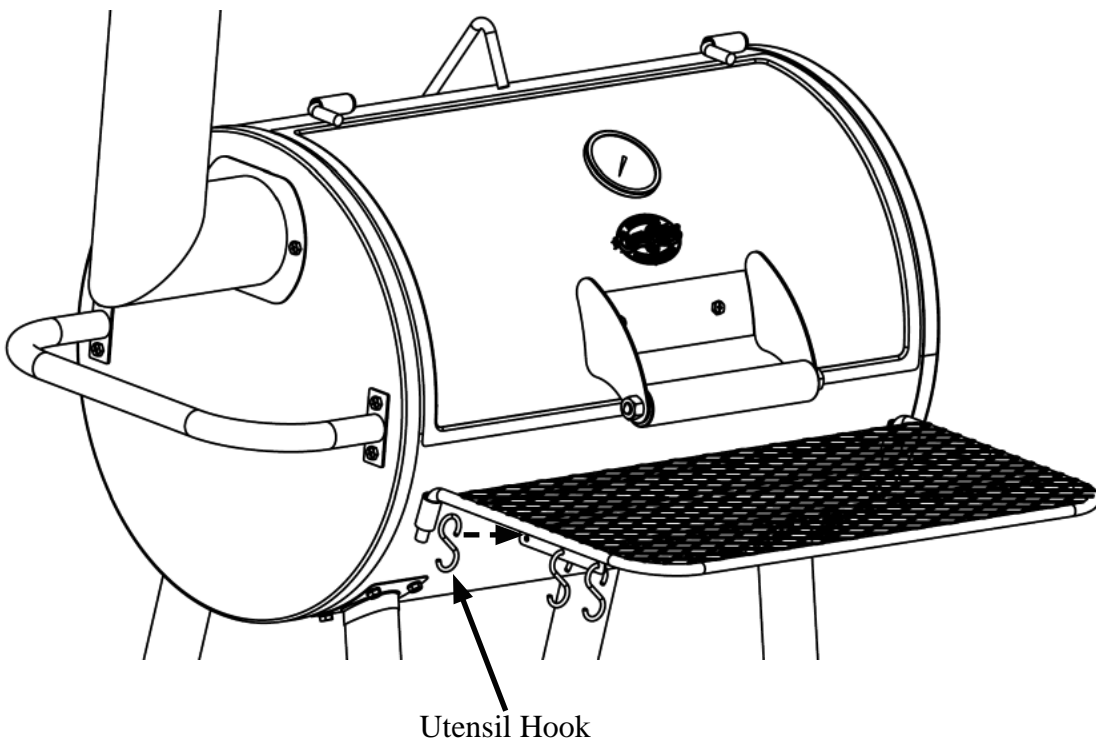

GRILL PREPARATION & OPERATING INSTRUCTIONS

PLEASE NOTE: NO RETURNS ON USED GRILLS

Read all safety warnings and instructions carefully before assembling and operating your grill. **NOTE:** Grill interiors are not painted, rather coated with vegetable oil. **DO NOT** remove this coating.

Cure both grills prior to cooking to protect interior and exterior finishes and prevent adding unnatural flavors to your food:

1. Lightly coat ALL INTERIOR SURFACES (including INSIDE OF BARREL, AND COOKING GRATES) with additional vegetable oil (spray vegetable oil is easiest but KEEP AWAY FROM HOT COALS, FIRE OR FLAME).
 2. Build a medium sized fire on the fire grate. Stack 2 lbs of charcoal (approximately 30 briquettes) in a pyramid and saturate with lighter fluid. **DO NOT** use gasoline. Light coals in several places. When charcoals ash over or turn gray, spread out from pyramid into flat single layer. Close CHARCOAL GRILL HOOD. ALWAYS follow charcoal and lighter fluid manufacturers' instructions and warnings. Do not use more than 3 lbs of charcoal.
 3. Maintain 250°F temperature on grill for two (2) hours. Control heat with DUAL DAMPERS and ADJUSTABLE FIRE GRATE. Adjust GRATE one end at a time. More airflow means more heat.
 4. NEVER EXCEED 450°F (230°C) AS THIS WILL DAMAGE THE FINISH AND CONTRIBUTE TO RUST. PAINT IS NOT WARRANTED AND WILL REQUIRE OCCASIONAL TOUCH-UPS. THIS UNIT IS NOT WARRANTED AGAINST RUST.
- For fewer flare-ups, cook with lid in the down position.
 - Add water-soaked wood chips to CHARCOAL GRILL for smoky flavor. (See Recipes section)
 - Ashes left in bottom of CHARCOAL GRILL for too long hold moisture and may cause rust if not cleaned out.
 - GRILL is made of steel and cast iron, which WILL rust, especially without proper care.
 - Do not use self-starting charcoal, as it gives off an unnatural flavor. Burn lighter fluid off completely before cooking.
 - After use, coat bare metal with vegetable oil to reduce rust. Remove EXTERIOR rust with wire brush and touch up with high heat paint, available at most hardware/auto stores.
 - Make sure to empty GREASE TRAY after every use once completely cooled.
 - HEAT GAUGES maintain moisture, which will result in steam during cooking.
 - Fill unwanted holes with extra nuts and bolts (not provided). Note: Smoke will escape from other areas than smokestacks. This will not affect cooking.
 - Grill must be installed on stable, flat surface.
 - It is recommended that CHARCOAL GRILL be heated up and fuel kept red hot for at least 30 minutes prior to first time cooking. Do not cook before briquettes have turned gray with ash.
 - WARNING! Accessible parts may be very hot. Use outdoors only.
 - WARNING! Do not use spirit or petrol when lighting or relighting.
 - WARNING! Keep children and pets away from appliance.

CUTS OF MEAT

BEEF CUTS

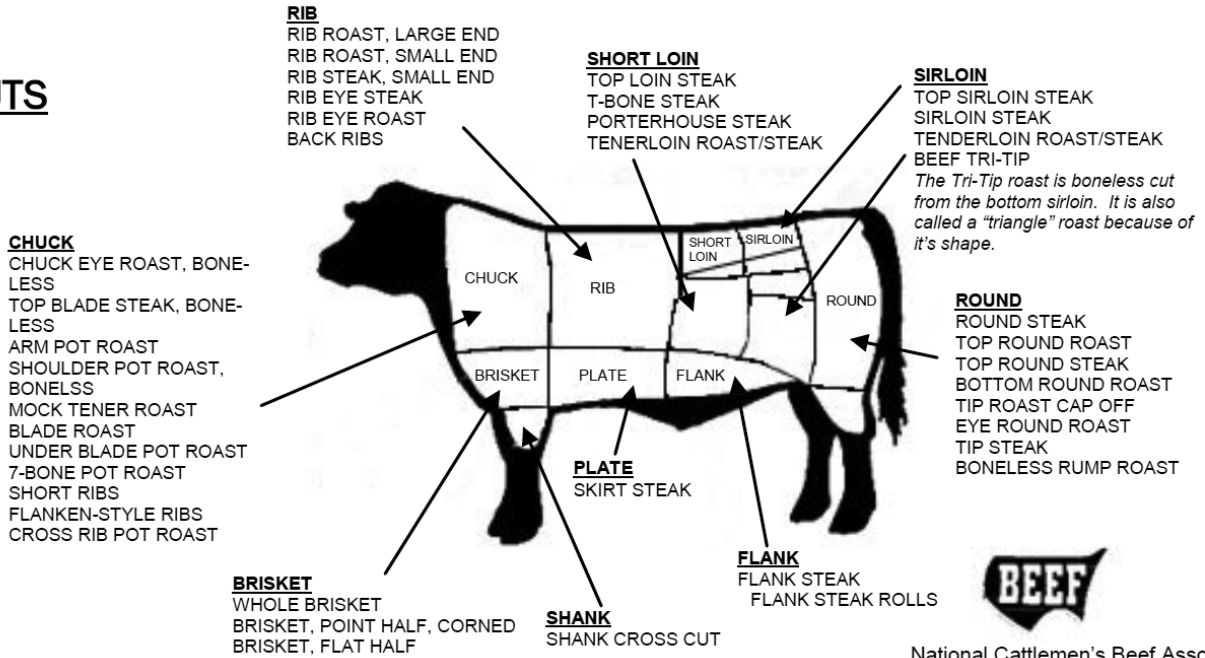

National Cattlemen's Beef Association
444 North Michigan Avenue
Chicago, Illinois 60611
(312) 467-5520

PORK CUTS

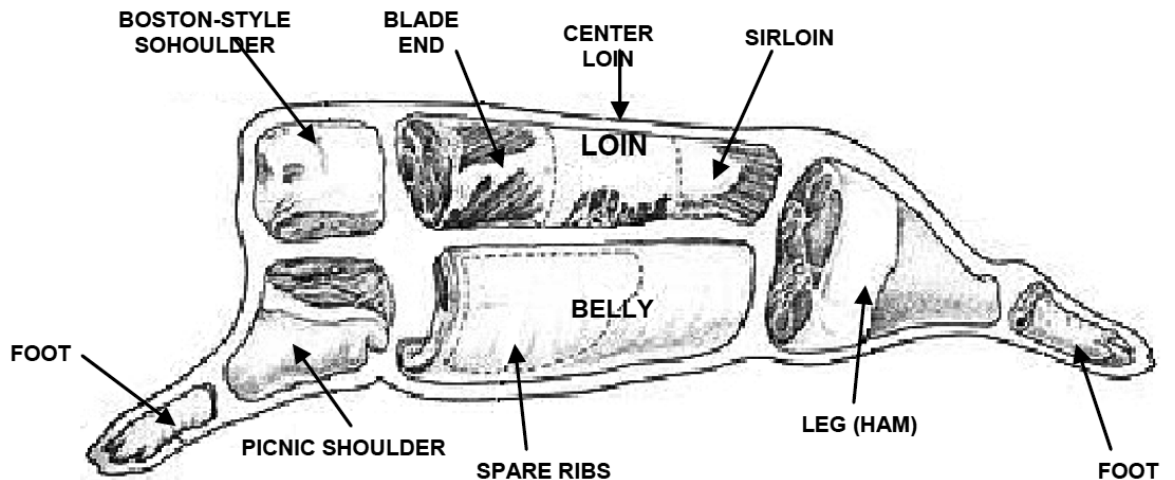

GRILLING RECIPES

Direct Heat

- Direct Heat is a high heat method used to cook foods that take less than 25 minutes to cook. Typically, this means foods that are relatively small or thin such as steaks, chops, boneless chicken breasts, fish fillets, hamburgers, etc.
- Cooking with a MEAT THERMOMETER ensures food is fully cooked. Insert into the thickest part not touching bone, and allow five minutes to register.
- Internal temperatures for FOWL should be 170°F to 180°F.
- Internal temperature for meat should be 140°F for rare, 160°F medium, and 170°F for well done.

STEAK (& ALL MEATS):

- Cook food directly above coals/heat.
- Control heat with adjustable fire grate.

Tip: Place grilled meat back in the marinade for several minutes before serving – it will become tastier and juicier.

CAUTION: Boil extra marinade first to kill bacteria remaining from the raw meat.

MARINATED FLANK STEAK:

- Mix marinade ingredients in nonmetal dish.
- Let steak stand in marinade for no less than 4 hours in refrigerator.
- Brown each side for 5 minutes, but center should remain rare.
- Cut steak diagonally across the grain into thin slices before serving.
- Grill with fire grate in high (hot) position with lid open or closed.

Meat Marinade

1/2 cup vegetable or olive oil
1/3 cup soy sauce
1/4 cup red wine vinegar
2 tbsp lemon juice
1 tsp dry mustard
1 minced clove garlic
1 small minced onion
1/4 tsp pepper



QUAIL OR DOVES:

- Cover birds in Italian dressing (Good Seasons or Kraft Zesty) and marinate overnight.
- Pour remaining dressing and cover with Texas Pete Hot Sauce for 6 hours.
- Wrap birds in thick bacon secured by a toothpick.
- Place on grill. Keep turning until bacon is black.
- Grill for 20 minutes. Sear with lid open and fire grate in high (hot) position for 1 minute on each side before lowering grate and closing lid.
- To SMOKE, place birds in center of GRID with fire in both ends of FIRE BOX.

KABOBS:

- Alternating on skewers any combination of meat, onions, tomatoes, green peppers, mushrooms, zucchini, circular slice of corn-on-the-cob, or pineapple. Meat could consist of chunks of shrimp, scallops, lobster, chicken, sausage, pork, beef, etc.
- Marinate the meat in refrigerator for several hours.
- Grill each side approximately 7 minutes turning occasionally while basting with marinade. Leave a small amount of room between pieces in order to cook faster.
- Grill with lid up and the fire grate in the lowest position. See marinade recipe on last page.

Kabob Marinade:

1 cup soy sauce
½ cup brown sugar
½ cup vinegar
½ cup pineapple juice
2 tsp salt
½ tsp garlic powder

- Mix all ingredients in a saucepan and bring to boil.
- Allow marinade to cool before marinating your meat in it.
- Marinate beef in mixture a minimum of 4 hours.

HOT DOGS:

- Grill with lid up and fire grate in high (hot) position for approximately 6 minutes.
- Turn every few minutes.

HAMBURGERS:

See Meat Marinade on page 40.

You may also marinate by allowing to stand in marinade for 1 or 2 hours at room temperature before cooking, or let stand in covered dish in refrigerator up to 24 hours.

- Bring to room temperature before cooking.
- Mix in chopped onions, green peppers, salt, sear 3/4 inch patties on each side with fire grate in high position for a few minutes.
- Lower fire grate to medium position and grill with lid down to avoid flare-ups.
- Cook each side 3 to 7 minutes according to desired doneness.
- Cook ground meat to 150 internally or until juice runs clear (free of blood) for prevention of E-coli.
- Burgers can be basted with marinade when turning and/or other ingredients can be mixed in with the ground beef such as chili sauce or powder.

SHRIMP (Peeled) & CRAYFISH:

- Place on skewers.
- Coat with melted butter and garlic salt.
- Grill 4 minutes on each side or until pink. Cocktail sauce optional.

BAKED POTATOES:

- Rub with butter and wrap in foil and cook on grill with lid down for 50 minutes.
- Turn after 25 minutes (no need to turn if smoked).
- Squeeze to check for doneness.

SWEET CORN IN HUSKS:

- Trim excess silk from end and soak in cold salted water 1 hour before grilling.
- Grill 25 minutes – turning several times.

SMOKING RECIPES

Indirect Heat

SMOKING TIMES



Food	Weight	Water Pan Smokin'	Side Fire Box	Temperature on Meat Thermometer
Beef Roasts, Beef Brisket	3 – 4 lbs.	1 – 1½ hours	4 – 5 hours	140° rare
Lamb Roasts, Venison	5 – 7 lbs.	1¾ – 2½ hours	5 – 6 hours	160° medium
Large cuts of Game	7 – 9 lbs.	2½ – 3½ hours	7 – 10 hours	170° well done
Pork Roasts	3 – 4 lbs.	1¾ – 2½ hours	5 – 6 hours	170°
	5 – 8 lbs.	2½ – 3 hours	7 – 8 hours	170°
Pork/ Beef Ribs	Full grill	1½ – 2 hours	4 – 6 hours	Meat pulls from bone
Pork Chops	Full grill	¾ – 1¼ hour	4 – 6 hours	Meat pulls from bone
Sausage Links	Full grill	2 – 2¾ hours	4 – 5 hours	170° for fresh sausage
Ham, Fresh	10 lbs.	3 – 4 hours	7 – 8 hours	170°
Ham, Cooked	All sizes	1½ – 2 hours	3 – 4 hours	130°
Chicken (Cut up or split)	1-4 fryers, cut up or split	1 – 1¼ hours	4 – 5 hours	180° / leg moves easily in joint
Chicken (Whole)	1-4 fryers	1¼ – 1½ hour	5 – 6 hours	180° / leg moves easily in joint
Turkey (Unstuffed)	8 – 12 lbs.	1¾ – 2½ hours	7 – 8 hours	180° / leg moves easily in joint
Fish, small whole	Full grill	½ – ¾ hours	2 – 3 hours	Flakes with fork
Fish, filets, steak	Full grill	¼ – ½ hours	1 – 3 hours	Flakes with fork
Duck	3 – 5 lbs.	1 – 1¾ hours	5 – 6 hours	180° / leg moves easily in joint
Small game birds	Full grill	¾ – 1 hour	4 – 5 hours	180° / leg moves easily in joint

Pan not included. Disposable bread pan is recommended. SMOKE BY COOKING SLOWLY (See chart above).

1. Place water/drip pan on left side of fire grate.
 2. Place hot coals on right side (damper end) of fire grate. The charcoal basket accessory helps confine coals to one side.
 3. Place meat above water pan.
 4. Place fire grate in low position.
 5. Close lid & control heat with dampers & adjustable grate.
- You may want to sear certain foods before smoking by placing meat directly above coals with LID open and FIRE GRATE in high (hot) position for several minutes. Add flavor soaked wood chips to the fire and add 1 part marinade, beer, or wine to 3 parts water to the drip pan.
 - OPENING THE SMOKING CHAMBER WILL EXTEND COOKING TIME. Cooking with meat thermometer ensures food is fully cooked. Insert thermometer into thickest part not touching bone, and allow five minutes to register. Internal temperature for birds should be 170°F to 180°F or when leg moves easily in joint. Meat should be cooked to internal temperature of 140°F for rare, 160°F for medium and 170°F for well done. Check the water level when cooking more than 4 hours or when you can't hear the water simmering. Add water by moving meat over and pouring water through GRILL into WATER PAN.
 - IF THE SMOKE IS WHITE, THE FIRE'S RIGHT. IF THE SMOKE IS BLACK, ADD SOME DRAFT.

SMOKED TURKEY:

- Empty cavity rinse and pat dry with paper towel.
- Tuck wing tips under the back and tie legs together.
- Place in center of cooking grid directly above foil drip pan of water.
- Smoke for 12 minutes per pound. Allow several extra minutes per pound if stuffed to allow for expansion.
- Use a meat thermometer for best results (190F internal).

SMOKED BAKED HAM:

You can smoke fully cooked canned ham or smoked and cured whole ham or shank or butt portion.

Glaze

1 cup of light brown sugar, firmly packed
1/2 cup orange juice
1/2 cup honey

- Combine sugar, juice and honey. Let glaze sit for at least 4 hours.
- Place fire grate in the lowest position and a drip pan under the meat.
- Remove rind and score fat diagonally to give a diamond effect.
- Insert a whole clove into the center of every diamond.
- Place ham with fat side up in center of cooking grid directly above drip pan. Close lid.
- About 9 minutes per pound is suggested for fully cooked hams. Smoked or cured ham, which is not fully cooked, should be cooked to an internal temperature of 160°F.
- Baste with ham glaze 3 or 4 times during last 30 minutes of cooking time.
- Garnish with pineapple rings about 15 minutes before end of cooking time.

SMOKED HOT DOGS STUFFED:

- Slit hot dogs lengthwise, within 1/4 inch of each end.
- Stuff hot dogs with cheese and relish and wrap in bacon.
- Place on cooking grid over drip pan and smoke 15-20 minutes or until bacon is crisp.

SMOKED CHICKEN PARTS AND HALVES:

- Rinse pieces in cold water and pat dry with paper towels.
- Brush each piece with vegetable oil and season to taste with salt and pepper.
- Brown pieces directly above coals with lid open and grate in high or medium position for several minutes.
- Then place pieces on cooking grate directly above drip pan.
- With the grate in the low position, cook with lid down for 55 to 60 minutes or until done. Do



not use vegetable oil or salt and pepper if using marinade.
SMOKED VENISON:

Venison Marinade:

- 1 cup Balsamic or wine vinegar
- 1 cup olive oil
- 2 oz. Worcestershire
- 1/2 oz. Tabasco
- 2 tbsp. Season All
- 1-2 chopped jalapenos
- 3 oz. soy sauce

Bacon Marinade

- 2 oz. wine vinegar
- 2 oz. Worcestershire
- 4 dashes Tabasco

- Place leg of venison in a container or “hefty bag” and marinate for 2-4 days, turning daily. Marinate bacon overnight in its marinade.
- Remove roast from refrigerator at least an hour before cooking.
- Season generously with seasoned salt and coarse ground black pepper.
- Wrap 1 lb. Bacon over the top of the roast, and smoke 20/25 minutes per pound, or until tender. Do not overcook.

SMOKED SHRIMP & CRAYFISH:

- Mix in a foil pan 1/2 cup butter, two cloves of crushed garlic, Tabasco, sliced green pepper, 1 tablespoon each of minced onions, salt and juices from one lemon.
- Add shrimp and/ or crayfish and smoke 45 minutes.

SMOKED VEGETABLES:

- Turnips, potatoes, carrots, okra, mushrooms, peeled onions, zucchini, squash, etc.
- Put in pan and cover with water and cook for several hours while cooking the meat. Or place vegetables on grill and smoke for 50 minutes, either wrapped in foil or not.

SMOKED FISH:

- Marinate in brine (1/4 cup dissolved in 1 qt of water) or marinate fish in 1 cup white wine, 1 cup soy sauce mixed with 1 cup lemon juice.
- Marinate overnight in covered dish in refrigerator.
- Let air on rack 20 minutes before placing on Pam-sprayed grill.
- Smoke 25 minutes.

SMOKED SPARE/BACK RIBS:

- Peel off tough layer of skin on back side.
- Rub all surfaces with seasoning.
- Place ribs in center of grid above drip pan and smoke approximately 1 1/2 hours or until meat pulls away from bone.
- Baste with barbecue sauce during last 30 minutes.

CHICKEN MARINADE:

Combine

1/2 cup soy sauce
1/4 cup vegetable oil
1/4 cup red wine vinegar
1 teaspoon oregano
1/2 teaspoon sweet basil
1/2 teaspoon garlic powder with parsley
1/4 teaspoon pepper

- Pour over chicken pieces in non-metal dish
- Cover and refrigerate overnight, turning occasionally. Use marinade to baste chicken while cooking.

MEAT MARINADE: (For steaks, chops, and burgers)

Combine

1/4 cup soy sauce
2 coarsely chopped large onions
2 cloves garlic (halved)

- Combine ingredients in an electric blender, cover, and process at high speed 1 minute or until mixture is very smooth.
- Stir in 1/4 cup bottle gravy coloring (Kitchen Bouquet and Gravy Master) and 2 teaspoons Beau Monde seasoning (or substitute 1 teaspoon MSG and 1 teaspoon seasoned salt).
- Allow meat to stand in marinade at room temperature for 2 hours or refrigerate up to 24 hours in a covered dish.
- Bring meat to room temperature before cooking.



SHISH KABOB MARINADE:

Mix

1 cup soy sauce
1/2 cup brown sugar
1/2 cup vinegar
1/2 cup pineapple juice
2 teaspoons salt
1/2 teaspoon garlic powder

- Mix ingredients and bring to a boil.
- Marinate beef in mixture a minimum of 4 hours.

ACCESSORIES

Custom Fit Cover #8195
Weather Resistant
Protects Grill Finish



Charcoal Basket
Confines Coals to One Side for
Smoking
Indirect Cooking



Apron #8805
Machine Washable
Two Front Pockets
Adjustable Straps

For Pricing or to Order,

Visit www.CharGriller.com

CALL: 912-638-4724



P.O. Box 30864
Sea Island, GA 31561
912-638-4724
www.CharGriller.com
Service@CharGriller.com

