

ASSEMBLY INSTRUCTIONS

SKU: WF191894

IMPORTANT NOTE:





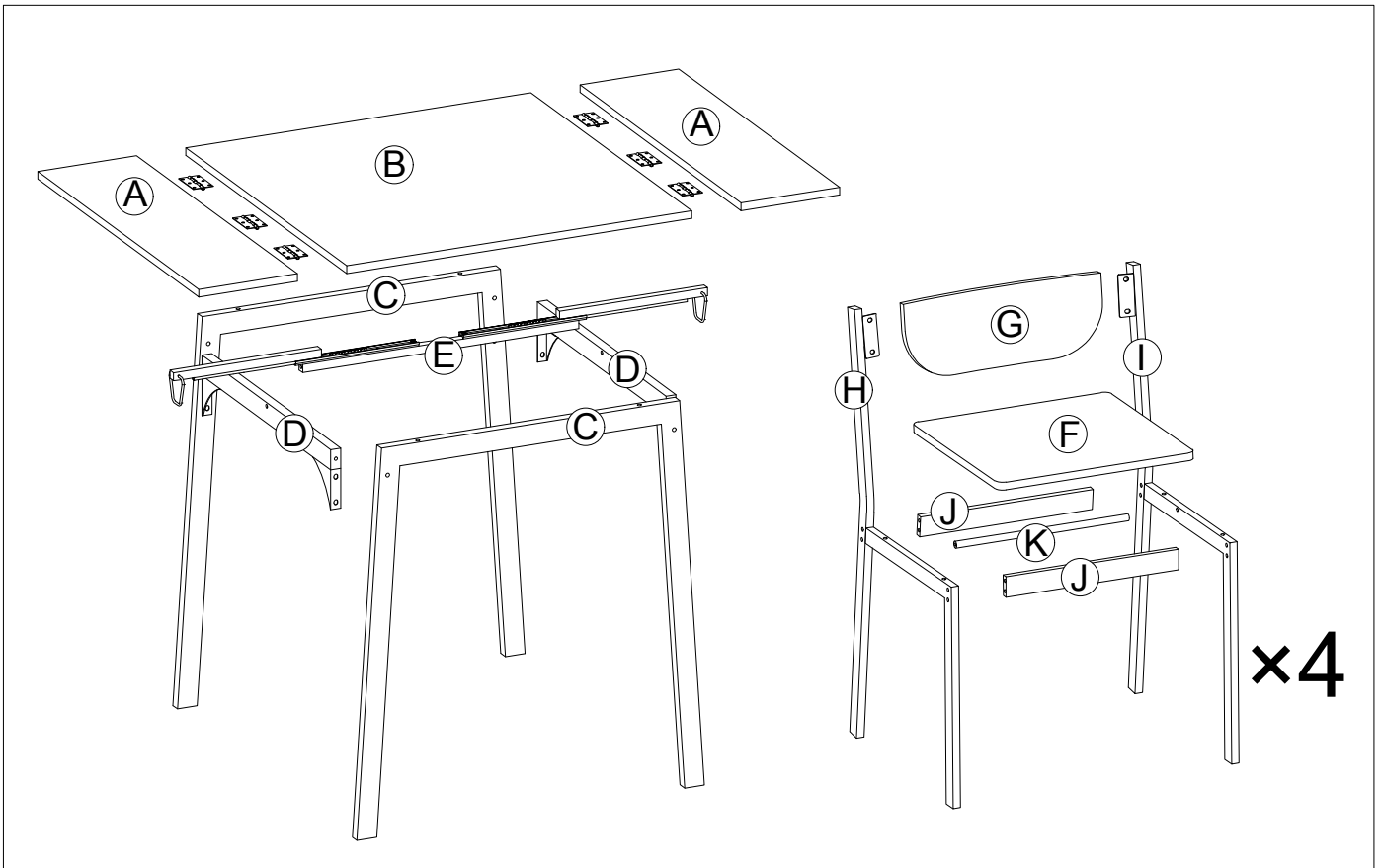
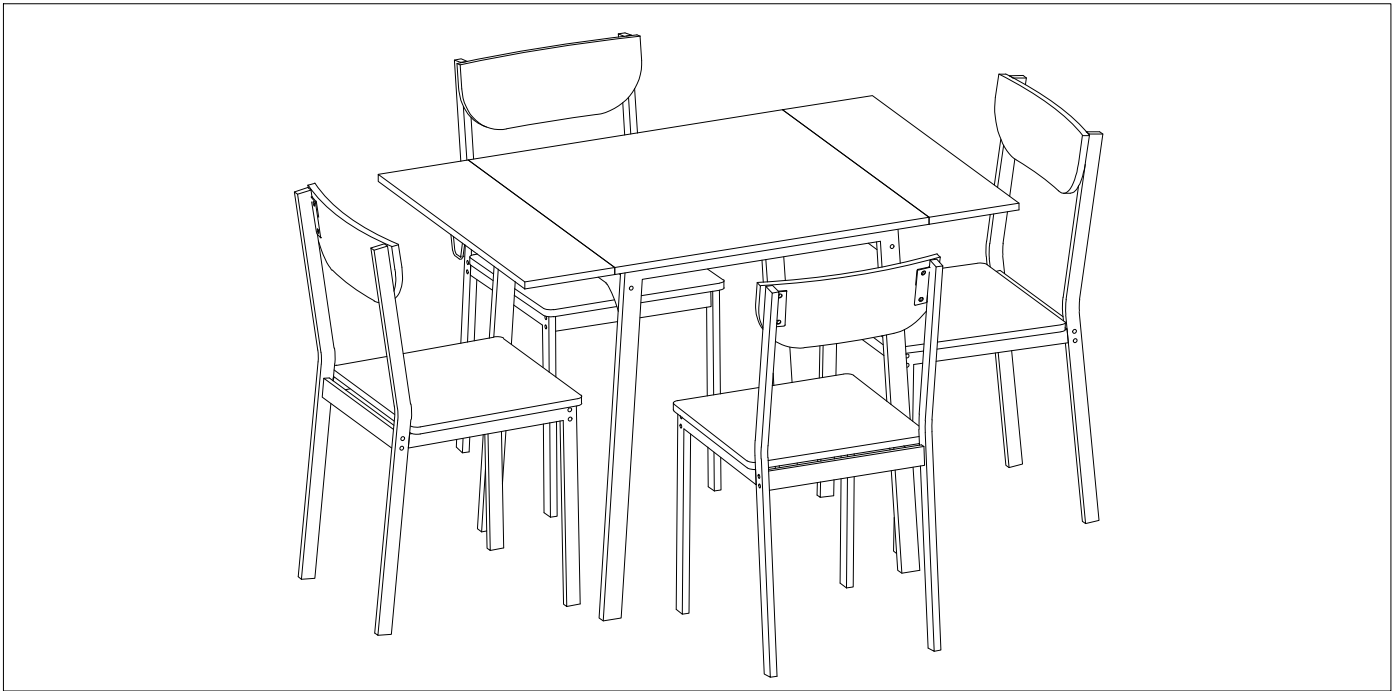

**PLACE ALL PARTS ON A CLEAN AND SMOOTH SURFACE SUCH AS A RUG OR CARPET TO AVOID THE PARTS FROM BEING SCRATCHED.

**BEFORE YOU BEGIN, KINDLY FOLLOW THE ASSEMBLY INSTRUCTIONS STEP BY STEP.

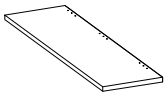
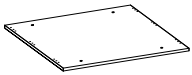
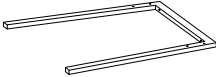



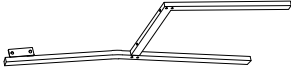
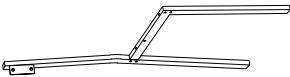

**DO NOT TIGHTEN ALL SCREWS AND BOLTS UNTIL THE CHAIR IS FULLY SET-UP.

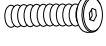
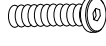
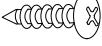

Part List

	
A×2pcs	B×1pc
	
C×2pcs	D×2pcs
	
E×1pc	F×4pcs
	
G×4pcs	H×4pcs
	
I×4pcs	J×8pcs
	
K×4pcs	

Hardware List

	
M6×12mm ①×20pcs	M6×32mm ②×40pcs
	
M6×40mm ③×22pcs	M6×50mm ④×4pcs
	
4×12mm ⑤×24pcs	Ø18×6×1.5t ⑥×4pcs
	
74×46mm ⑦×4pcs	M4 ⑧×1pc

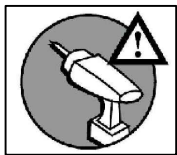

PLEASE BE CAREFUL DO NOT DAMAGE THE HOLE POSITION WHEN YOU USE POWER TOOLS !

Step 1

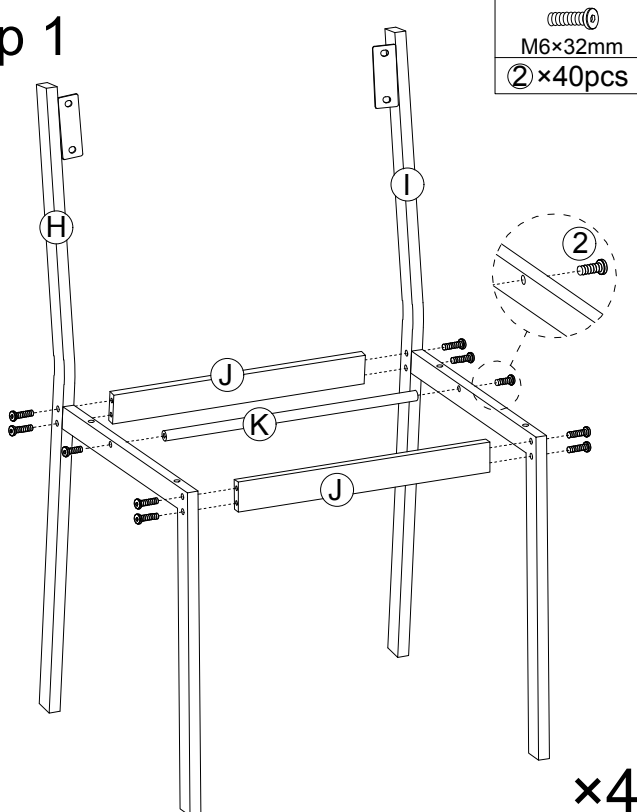

Step 2

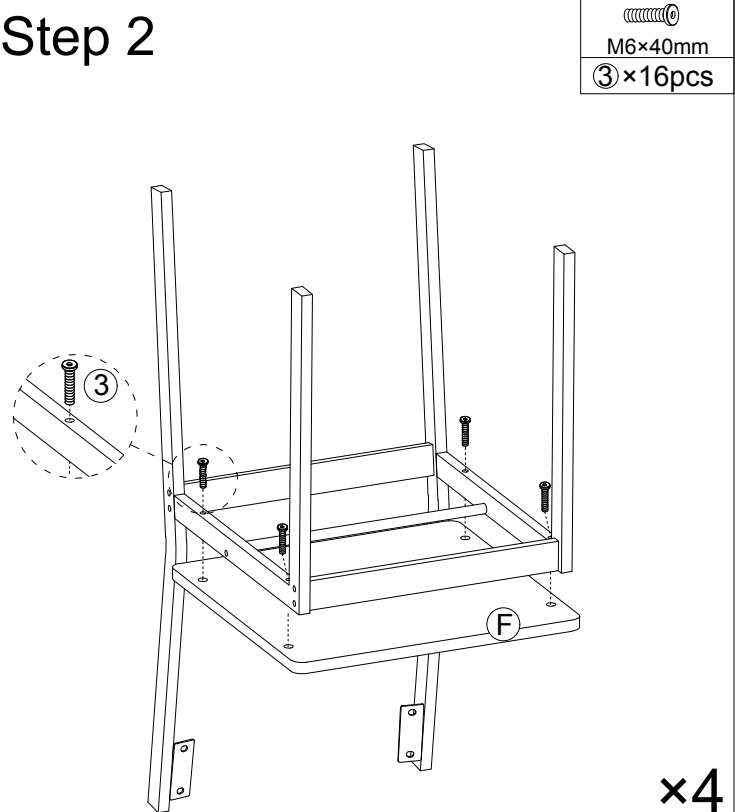

Step 3

 M6×12mm
①×16pcs

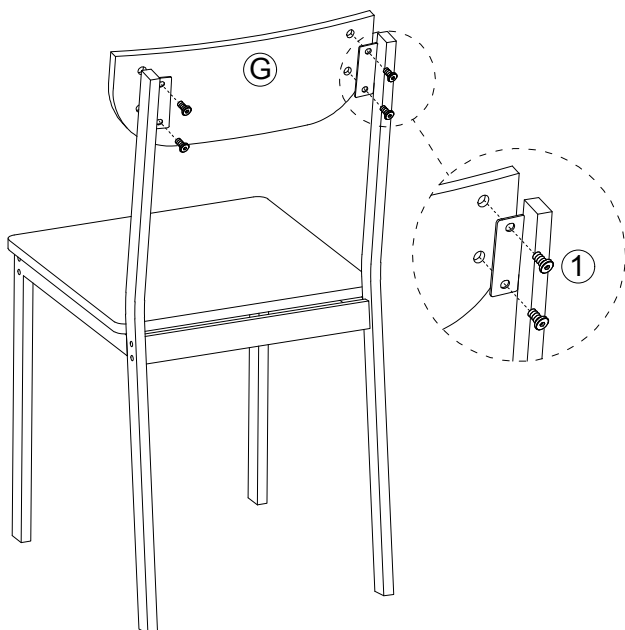

×4

Step 4

 M6×40mm
③×2pcs

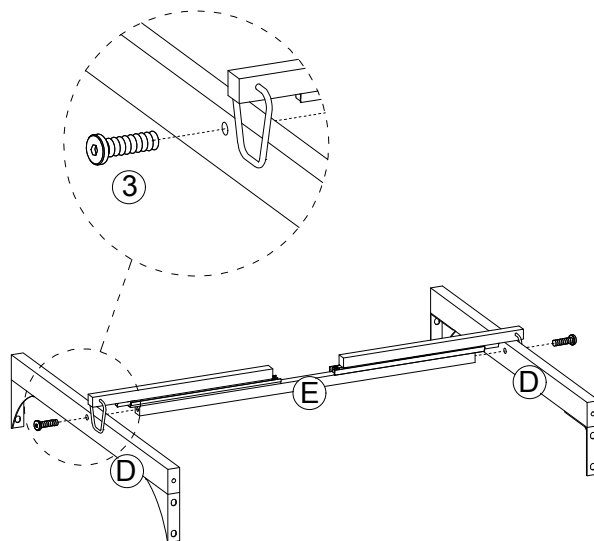

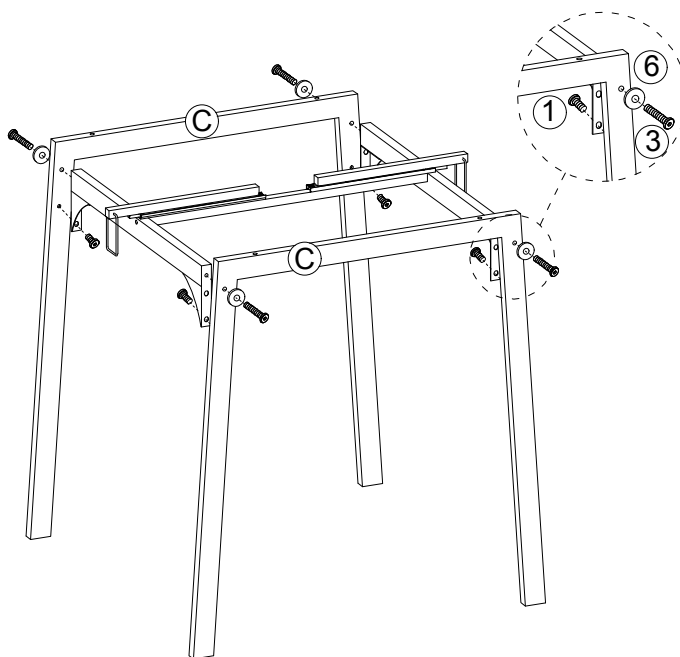

Step 5

 M6×12mm ①×4pcs	 M6×40mm ③×4pcs	 Ø18×6×1.5t ⑥×4pcs
---	---	--



Step 6

 4×12mm ⑤×24pcs	 74×46mm ⑦×4pcs
---	---

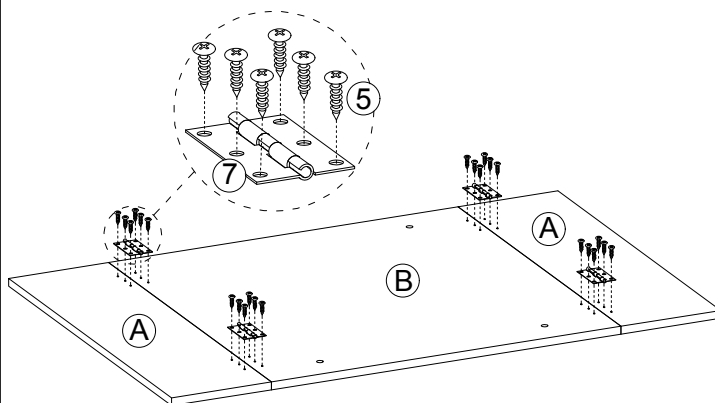

Step 7

M6×50mm
④×4pcs

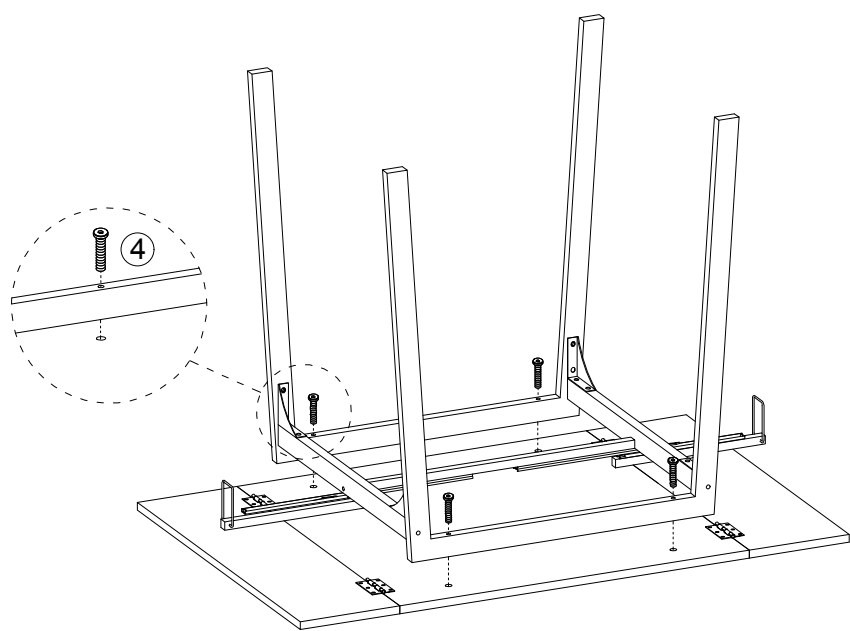

Step 8

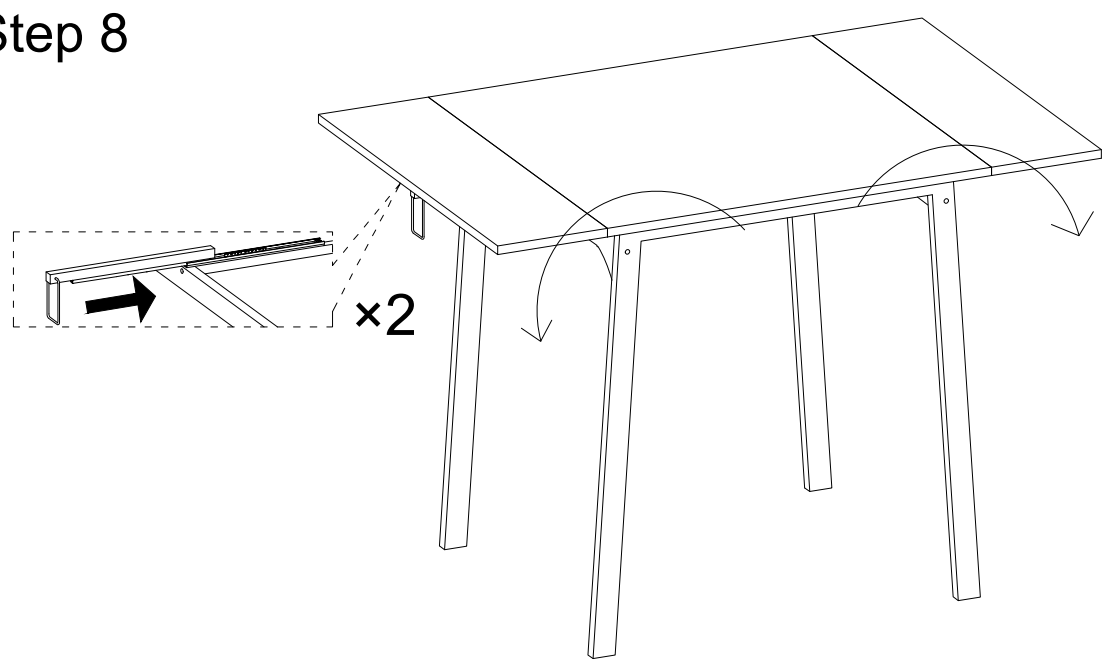

Step 9

