



**Two Shelf Polypropylene
Service Cart
Model # 73002**



INSTRUCTION MANUAL

For questions concerning this product, please contact our customer service department at

(800) 232-1195 Mon. through Fri. 8am - 5pm CST

Or email us at: partsandservice@greatlakespec.com

Thank you for purchasing the Wen Service Cart. You will enjoy using the cart to transport up to 500lbs of material in whatever setting you use the cart.

We advise keeping this Instruction Manual and recording the Purchase Date : _____ and saving the receipt by attaching it to the Instruction Manual in case you need to exercise the Warranty located on the last page of this manual.

SPECIFICATIONS

| | |
|-------------------|--|
| Model: | 73002 |
| Maximum Capacity: | 500 lbs |
| Tray Size: | 30"L x 16"W x 3"Deep |
| Casters: | 2 fixed and 2 swivel, 5" Diameter x 1" Wide, Non-marring casters |

IMPORTANT SAFETY INSTRUCTIONS

Safety Warnings and Precautions

Warning: When using product, basic safety precautions should always be followed to reduce the risk of personal injury and damage to equipment.

Read all instructions before using this product!

1. **Keep work area clean.** Cluttered areas invite injuries.
2. **Observe work area conditions.** Keep work area well lighted.
3. **Store idle equipment.** When not in use, the Service Cart must be stored in a safe and clean location. Always secure products and keep out of reach of children.
4. **Use the right product for the job.** There are certain applications for which the Service Cart was designed. Do not modify the Service Cart and do not use the Service Cart for a purpose for which it was not intended.
5. **Check for damaged parts.** Before using any product, any part that appears damaged should be carefully checked to determine that it will operate properly and perform its intended function. Check for any broken or damaged parts and any other conditions that may affect its operation. Replace or repair damaged or worn parts immediately.
6. **Replacement parts and accessories.** When servicing, use only identical replacement parts. Use of any

other parts will void the warranty.

7. **Do not operate product if under the influence of alcohol or drugs.** Read warning labels on prescriptions to determine if your judgment or reflexes are impaired while taking drugs. If there is any doubt, do not operate the product.
8. **Use eye protection.** Always wear ANSI approved impact safety goggles.
9. **Do not exceed the product's maximum load capacity of 500 lbs (250 lbs per shelf).**
10. **Only use on a flat surface capable of supporting the Service Cart and its maximum capacity load of 500 lb.** It is easy to lose control of the Service Cart if attempting to pull a load on a sloping or uneven surface.
11. **Do not allow children to play on, stand upon or climb on the Service cart.** The Service Cart is not for carrying people or animals.
12. **Always check hardware and assembled parts after assembling.** All connections should be tight and hardware tightened.
13. **Always distribute objects in the Service cart evenly.** Uneven weight distribution could cause tipping. Do not lean or climb on the Service Cart.

Warning: The warnings, cautions, and instructions discussed in this instruction manual cannot cover all possible conditions and situations that may occur. It must be understood by the operator that common sense and caution are factors which cannot be built into this product, but must be supplied by the operator.

UNPACKING

When unpacking your Service Cart, please check the parts list and make sure all components are included. The parts list can be found on Page 4.

ASSEMBLY

NOTE: Please refer to the Assembly Diagram for the following assembly instructions:

1. Select the shelf tray with the uninterrupted flat surface identified as (part 1) and place it upside down on a flat work surface.
2. Locate the push handle, (part 3), turn it upside down with the cup holder towards the shelf tray, using a rubber mallet, tap the push handle down into the grooves on the tray. Make sure the handle is all the way on the shelf tray. Helpful Hint: To overcome the friction between two plastic surfaces, rub a little petroleum jelly onto the grooved surface. The two parts should slide together with a few gentle taps of the rubber mallet.

3. Since all 4 legs, (parts 5 & 6) look alike, positioning of the legs can be confusing. Here is an easy way to assemble the legs on the cart. Locate the two legs, (part 5) (note the positions of the bottom flanges) and place one nearest the handle (part 3) and the other diagonally across the shelf tray corner as shown on the assembly diagram. Using a rubber mallet, tap the legs onto the shelf tray (part 1) until the tab with the 3 screw holes is in contact with the shelf tray. Repeat the process with the other two legs (part 6) so all four legs are in solid contact with the shelf tray.
4. Insert and tighten the three screws per leg so that the legs are solid in the shelf tray (part 1). Hint: Rub some soap on the screw before inserting and tightening it. The soap acts as a lubricant and makes tightening the screw easier.
5. Now for the second tray (part 2). Turn the shelf tray upside down and place it onto the 4 legs (parts 5 & 6). The flanges on the 4 legs should fit into the depressions in shelf tray (part 2). Everything should fit together if all 12 screws were secured through the 4 legs into the shelf tray (part 1). Gently tap shelf tray (part 2) onto the 4 legs until the tabs and shelf tray depressions are in contact with each other.
6. Insert the carriage bolts (part 10) up through the leg tabs and the shelf tray (part 2) and begin the attachment of the casters. NOTE: The swivel casters (part 8) are located on the same side as the tray (part 3). With the carriage bolt held in place, position the appropriate caster (part 8 or 9) over the bolt, add the split washer (part 11) and hand tighten the nut (part 12). When all 4 nuts are in place, use an adjustable wrench. Repeat process with the other 3 legs until all casters are secured in place.
7. Turn the Service Cart upright. Make certain all hardware is tight. Make certain the casters roll properly and enjoy using the cart.

PARTS LIST

| Part | Description | Qty | Part | Description | Qty |
|-------------|--------------------|------------|-------------|--------------------|------------|
| 1 | Tray | 1 | 9 | Fixed Casters | 2 |
| 2 | Second Tray | 1 | 10 | Carriage Bolts | 16 |
| 3 | Handle | 1 | 11 | Washers | 16 |
| 4 | Pole on Handle | 1 | 12 | Nuts | 16 |
| 5 | Legs | 2 | | | |
| 6 | Legs | 2 | | | |
| 7 | Screw | 12 | | | |
| 8 | Swivel Casters | 2 | | | |

ASSEMBLY DIAGRAM

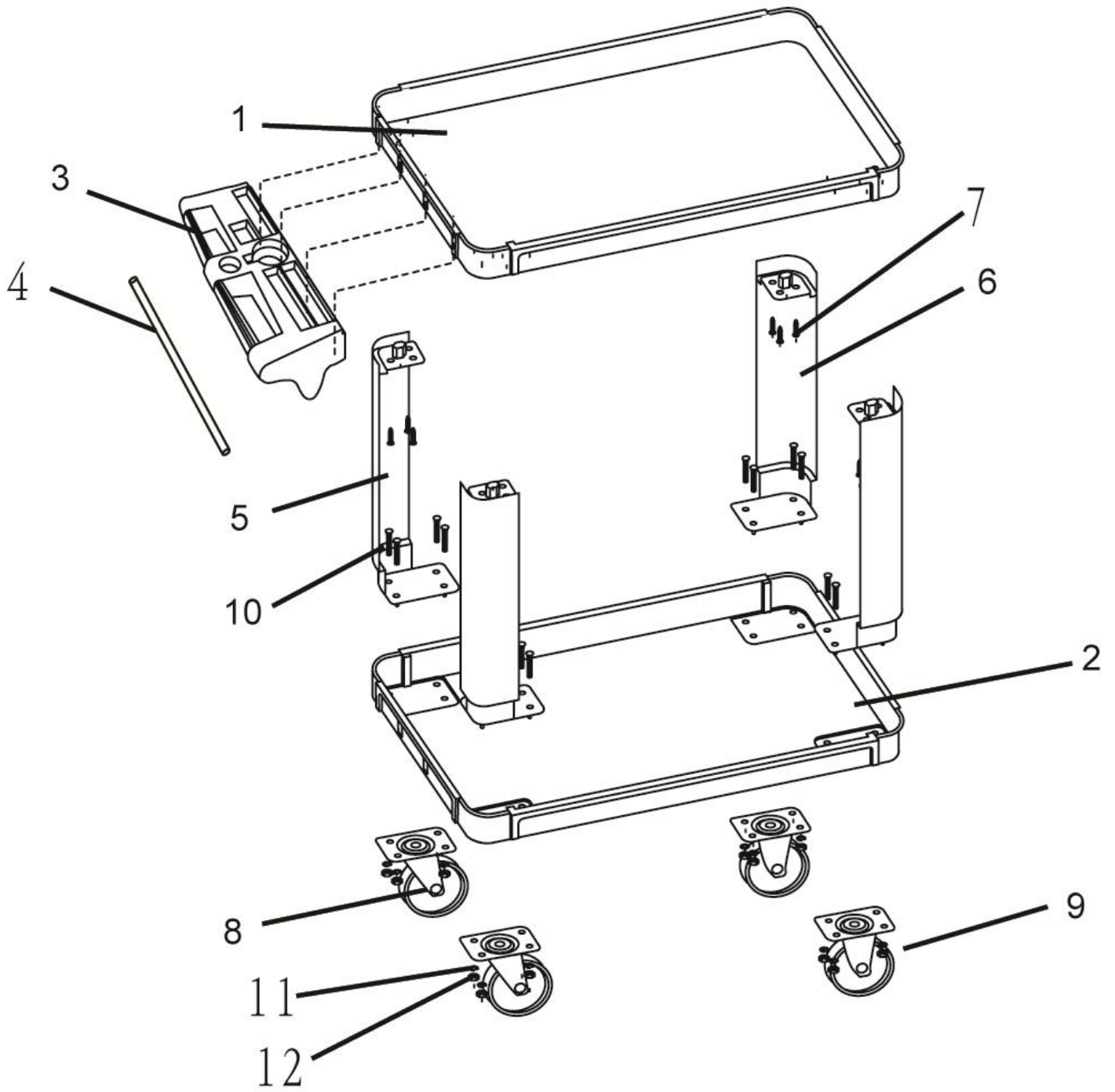

WARRANTY

1 Year Limited warranty

If during normal use, the Wen Service Cart fails in any manner due to a defect in materials and/or workmanship, Great Lakes Technologies, LLC will replace the cart within the first year from the date of purchase. Please call 800-232-1195 and a Customer Service Representative will assist you with a warranty claim. This warranty is null and void should the cart be used in a commercial or rental setting or if the cart weight limits are exceeded or used in a way that damages the cart.

The warranty does not cover any loses, injuries to persons/property or costs associated with the need to replace the cart under the warranty. This warranty does give you special legal rights and you may have other rights, which vary from state to state.

For questions/comments/technical assistance/repair parts:

Call 800-232-1195 (Mon.- Fri. 8AM - 5PM CST)