

MANUAL

ITEM # 07494

49" x 29-1/2" x 8" HITCH HAULER



WARNING:

To avoid personal injury and/or property damage, please read and follow ALL of these instructions before assembling and operating.

Only use the cargo carrier with a properly installed 2 in hitch receiver capable of supporting the Cargo Carrier and its load. Refer to Hitch Manufacturers specifications and load capacities before using

Tools Required:



Open Wrench
Size = 24 mm



Open Wrench
Size = 16 mm



Adjustable Wrench
Size = 30 mm



Hex Key
Size = 6 mm

CARRIER ASSEMBLY

Step 1: Attaching Support Bracket

- Place the carrier (#1) on a flat and secure work area that is able to support the weight of the carrier.
 - Align the square holes on the support bracket (#3) with the square holes on the edge of the carrier.
 - To secure the support bracket to the carrier, slide the M10 Carriage Bolts (#2) through the square holes and tighten using the U-Clamp (#4) and M10 Lock Nut (#5)
 - See FIG 1 for illustration.
- à travers les orifices carrés et resserrez-les à l'aide d'une l'attache en "U" et d'un contre-écrou M10.
- Consultez le dessin de la FIG 1.

PARTS NEEDED

- #1. Carrier
- #2. M10 Carriage Bolt
- #3. Support Bracket
- #4. U Clamp
- #5. M10 Lock Nut

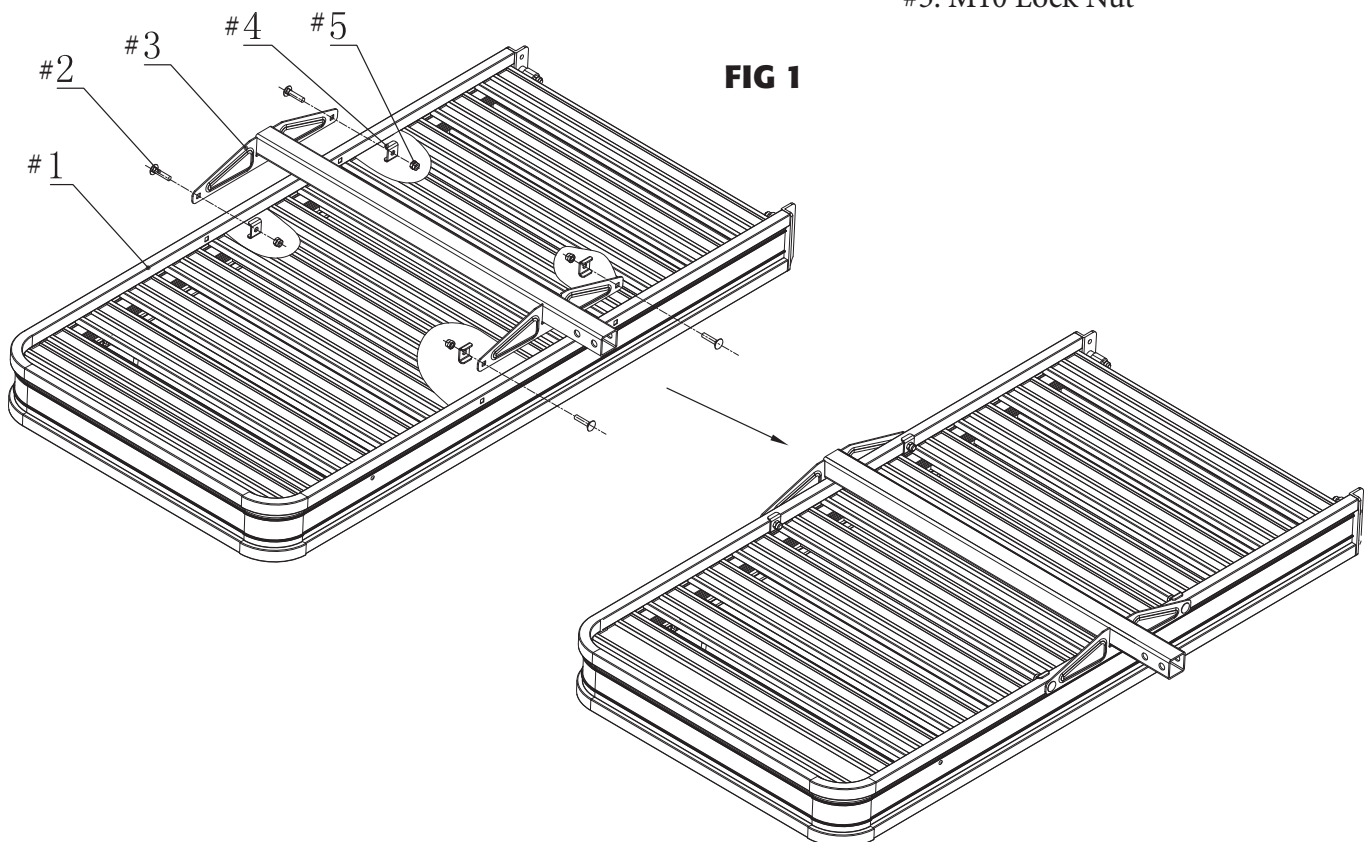

STEP 2: ATTACHING HARDWARE

- Flip the carrier 180 degrees so the support bracket is now on the bottom.
- Align the left side locking plate (#8) with the top two holes on the corner of the carrier.
- Use Insert the Lifting Bolt (#7) with M10 Lock Nut (#5) in the top hole and M10 Hexagon Socket Button Head Screws Screw (#6) with M10 Lock Nut in the bottom hole.
- Repeat the above steps with the right side. (Only 1 plate in Parts List)
- See FIG 2 for illustration.

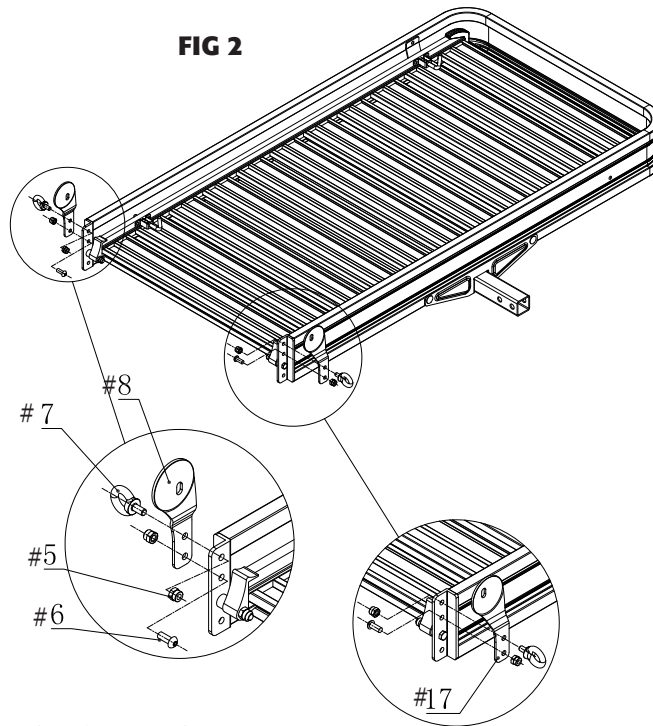

PARTS NEEDED

- #5 M10 lock nut
- #6 M10 head screw
- #7 Lifting bolt
- #8 Locking Plate

STEP 3: ATTACHING FOLDING BAR

- Align the top two holes one on the Folding Bar (#9) with the holes on the end of Support Bracket.
- Slide the M16 Bolt (#12) through the holes closest to carrier and tighten with M16 Lock Nut (#11).
- Slide the 5/8" Locking Pin (#13) through the holes closest to the vehicle and secure with the Safety Pin Pin Clip (#10).
- See FIG 3 for illustration.

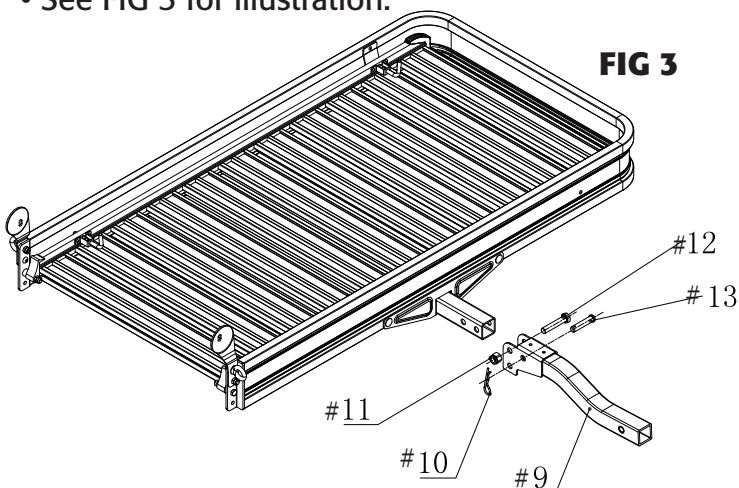

PARTS NEEDED

- #9. Folding Bar
- #10. Safety Pin
- #11. M16 Lock nut
- #12. M16 Bolt
- #13. 5/8" Locking Pin

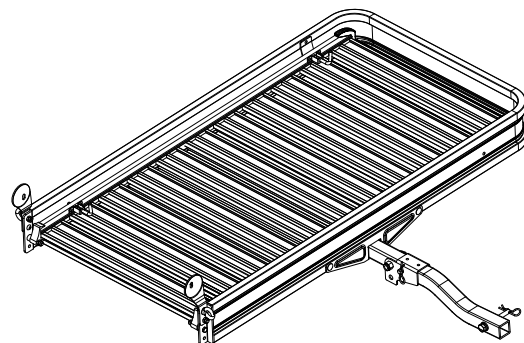

STEP 4: ATTACHING TO HITCH RECEIVER

- Insert Folding Bar (#9) into Hitch Receiver (Attached to vehicle, not included).
- Slide the M16 Spring Washer (#15) and M16 Flat Washer (#16) onto the M16 Threaded Pin (#14) then insert that through Hitch Receiver and Folding Bar and secure with Safety Pin (#10).
- See FIG 4 for illustration.

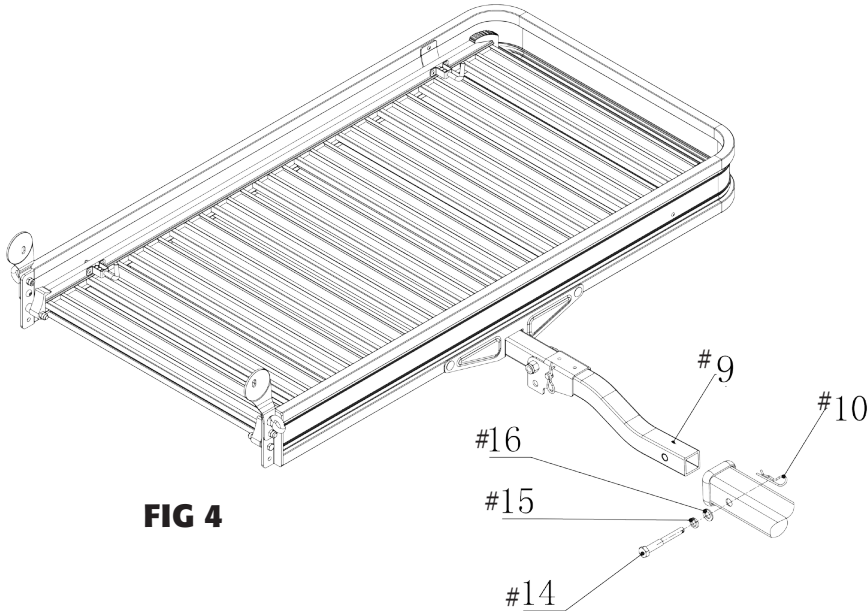

FIG 4

PARTS NEEDED

- #9. Folding Bar
- #10. Safety Pin Pin Clip
- #14. M16 Threaded Pin
- #15. M16 spring washer
- #16. M16 flat washer

Ramp Folds up



Ramp Folds down and in



Ramp Folds up against the vehicle



PARTS	Description	Q'ty
1	Carrier	1
2	M10 carriage bolt	4
3	Support bracket	1
4	U clamp	4
5	M10 lock nut	8
6	M10 hex socket button head screw	2
7	Lifting bolt	2
8	Locking Plate	2
9	Folding Bar	1
10	Safety Pin	2
11	M16 Lock nut	1
12	M16 Bolt	1
13	5/8" Locking Pin	1
14	M16 Threaded Pin	1
15	M16 spring washer	1
16	M16 flat washer	1
17	Right spoon-shaped mounted plate	1

