



INSTRUCTION MANUAL

Eat well, drink well and live well with Omega

www.omegajucers.com

NC800/NC900 Masticating Juicer



English, May 2013

PLEASE READ THESE INSTRUCTIONS CAREFULLY BEFORE USE

IMPORTANT SAFEGUARDS

When using electrical appliances, basic safety precautions should always be followed, including the following:

1. Read all the instructions before using the juicer.
2. To protect against risk of electrical shock, do not put the main body (motor) in water or any other liquid .
3. Close supervision is necessary when any appliance is used by or near children.
4. Unplug from outlet when not in use, before assembling or taking off parts and before cleaning
5. Avoid contact with moving parts.
6. DO NOT operate appliance with a damaged cord or plug or after the appliance malfunctions, or is dropped or damaged in any manner. Return appliance to the nearest authorized service facility for examination, repair or electrical or mechanical adjustment.
7. The use of attachments not recommended or sold by the manufacturer may cause fire, electric shock or injury.
8. DO NOT let cord hang over edge of table or counter.
9. Always make sure juicer locking clip is locked while juicer is in operation.
10. Be sure to turn switch to OFF position after each use of your juicer. Make sure the motor stops completely before disassembling.
11. DO NOT put your fingers or other objects into the juicer opening while it is in operation. If food becomes lodged in the opening, use the food plunger or another piece of fruit to push it down. When this method is not possible, turn the motor off and disassemble juicer to remove the remaining food.
12. Read all the instructions and operating procedures before plugging in and using appliance.
13. DO NOT unplug from electrical outlet by pulling on the cord. To unplug, grasp the plug, not the cord and pull.
14. Turn off all controls before unplugging from or plugging into an electrical outlet.

WARNING: This appliance has a polarized plug (one blade is wider than the other). To reduce the risk of electrical shock, this plug will fit in a polarized outlet one way. If the plug does not fit fully into the outlet, reverse the plug. If it still does not fit, contact a qualified electrician. DO NOT attempt to modify the plug in any way.

OMEGA MODEL NC800 NUTRITION CENTER

This heavy-duty juicer features a patented, stone mill-like auger, made of hygienic U.S. FDA-approved melamine.

The Omega NC800/NC900 Nutrition Center's low speed of 80 RPMs ensures full taste and the highest nutritional value.

The Omega NC800/NC900 Nutrition Center is easy to assemble and disassemble for quick cleaning.

The Omega NC800/NC900 Nutrition Center assures you many years of trouble-free, dependable service.

MULTI-PURPOSE JUICER/FOOD PROCESSOR

To care for your blender, please read the tips as follows:

1. **Fruit Juice Extractor**

The Omega efficiently juices soft and hard fruits, even citrus fruits, one of the hardest fruits to juice.

2. **Vegetable Juice Extractor**

The Omega efficiently juices all kinds of vegetables, including celery, carrots, peppers, radishes, and cabbage without destroying the natural flavor and nutrition. Fresh taste and full nutrition is guaranteed with this unique extraction process.

3. **Grass Juice Extractor**

Wheat grasses, aloe leaves and pine tree leaves are just some of the other natural products you can juice with the Omega. Enjoy the best that nature offers in raw foods of all kinds. Juice them for full nutritional benefits.

4. **Processing /Chopper Functions**

The Omega also chops and processes, garlic, scallions, red pepper, ginger, radish and many other foods, including herbs and seasonings, providing natural flavor and nutrition. Soft foods for babies and geriatric patients are quick and easy to prepare with the processing strainer.

5. **Pasta Maker**

Make fresh noodles in just minutes with the pasta nozzles.
See page 13 for more information.

6. **Homogenizer**

Make fresh frozen desserts, natural baby food, and nut butters.

7. **Grinder**

Grind coffee beans and flour.



Locking Clip

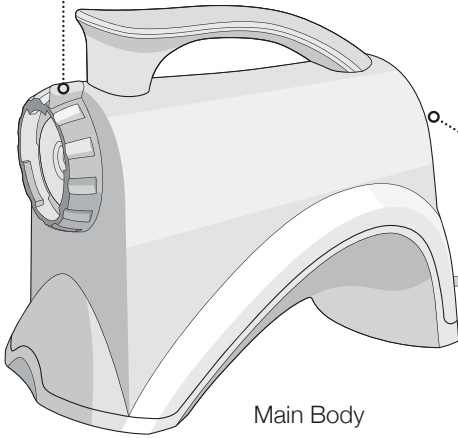

Main Body



ON-OFF
Switch

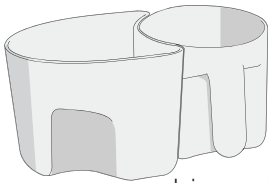
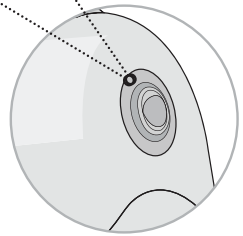

Pulp container

Juice container



Cleaning brush

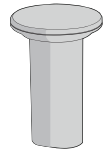

Food pusher

Parts for juicing

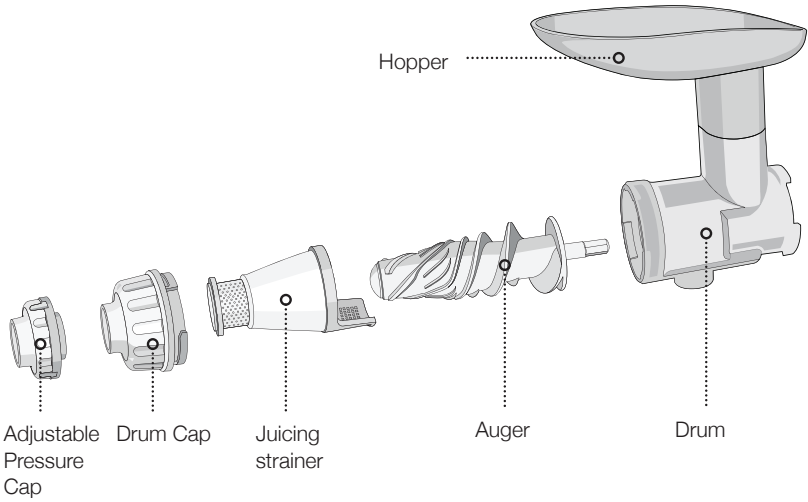

Parts for Processing

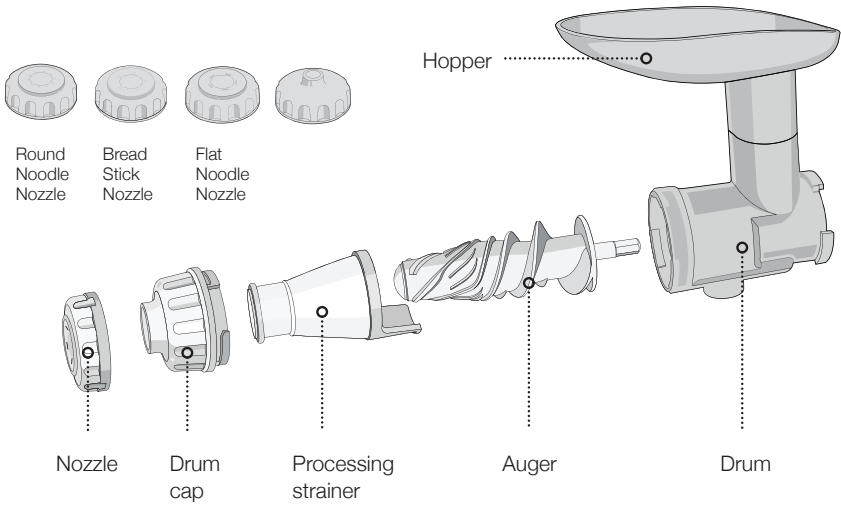



Juice fruits and vegetables
Juice grasses
Mince herbs & seasonings
Make noodles and bread sticks
Make baby food and sorbets

Specifications

Model Name	OMEGA NC800/NC900
Dimensions	Length: 484 mm Width: 183 mm Height: 328 mm
Voltage	120V/60Hz (150W power)
Motor	Single-phase induction
Auger RPM	75-85
Fuse	65TL 250V 8A
Certified	UL

Parts and Accessories Included with Your Juicer

1 User Manual	1 Processing Strainer
2 Bowls	1 Food Pusher
2 Round Noodle Nozzle	1 Hopper
2 Flat Noodle Nozzle	1 Cleaning Brush
1 Auger	1 Drum Cap
1 Drum	1 Adjustable pressure cap consisting of juicing nozzle with a tube ring.
1 Juicing Strainer	

Total of 16 parts including this manual

1. Thoroughly wash unpeeled fruit and vegetables before juicing.
2. Cut fruit or vegetables into small pieces (about 2 inches) so juice may be extracted more thoroughly.
3. Turn on the machine. Let it run without interruption until all the juice has been extracted.
4. If the juicer starts to vibrate slightly during operation, turn off the machine. Empty the drum set. Re-assemble and resume normal operation.
5. After placing the last pieces of fruits or vegetables into the hopper, keep the machine running for a few seconds to ensure the machine has extracted the last drops of juice.
6. Turn off machine.
7. Clean drum set after each use.
8. Do NOT run the machine for more than 30 minutes at a time.

CLEANING INSTRUCTIONS

Wash the auger and parts in warm, soapy water in your kitchen sink and rinse well.
Do not place parts or accessories in your dishwasher.
Do not immerse unit in water. Clean with a damp cloth.

MAKING JUICE

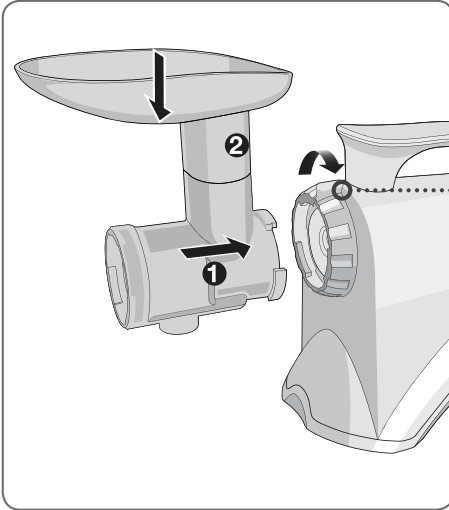

Assembly 1

Connect drum with main body by turning locking clip clockwise (about 60°).
Place hopper onto guide.

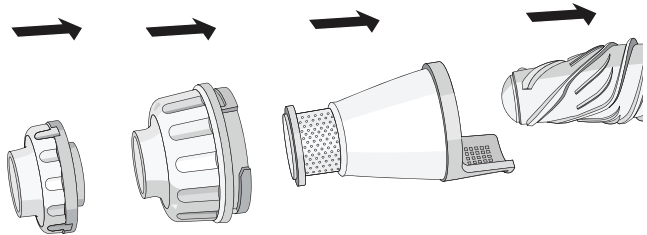
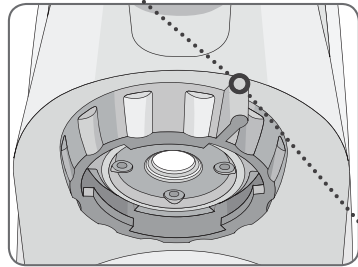

Assembly 2

For juicing function:

Place the auger into the drum.

Insert the juicing strainer into the drum.

Place the drum cap onto the drum end and turn it counter clockwise until it clicks firmly into place. Attach adjustable pressure cap to the drum cap end.

Turn to "5" on the adjustable pressure cap for maximum pressure. This is best for carrot, beetroot and the leafy greens.

Turn to "1" or "2" for soft fruits like orange, strawberry etc..

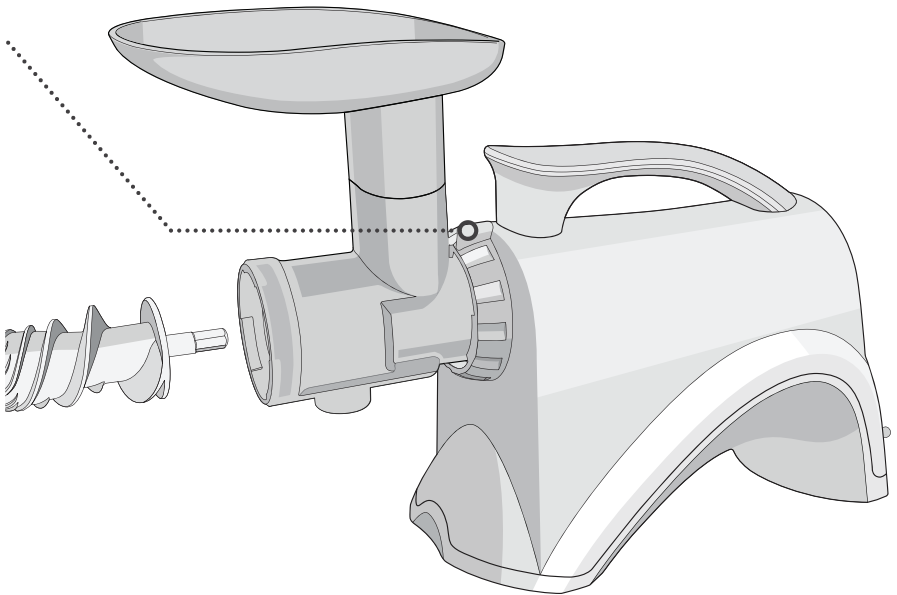

ASSEMBLY INSTRUCTIONS

Food Processor Function

For processing function:

Place the auger into the drum.

Insert the juicing strainer into the drum.

Place the drum cap onto the drum end and turn it counter clockwise until it clicks firmly into place.

If interested in making pasta, u-dong or noodles please refer to the "Making Pasta" section.

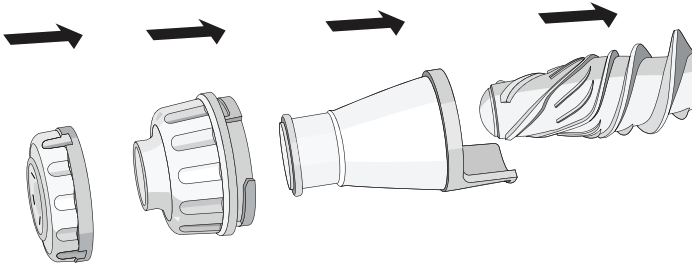

Assembly 3

When juicing, place juice bowl and pulp bowl under drum set. When processing, you won't need the juice bowl. Plug power cord into wall outlet.

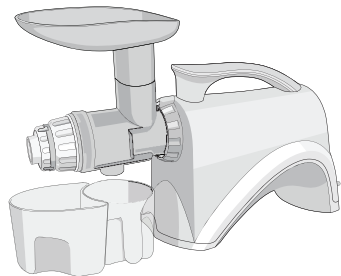

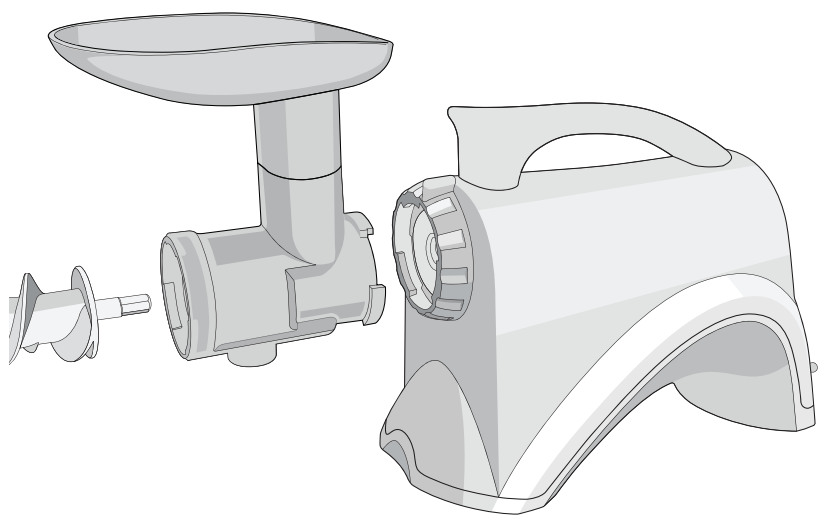

Assembly 4

Press the ON button. Place a few pieces of cut fruit or vegetables, one at a time into the guide. Use the food pusher to press the fruit or vegetables gently down the guide. Leave the machine on as you feed in the fruits/vegetables.

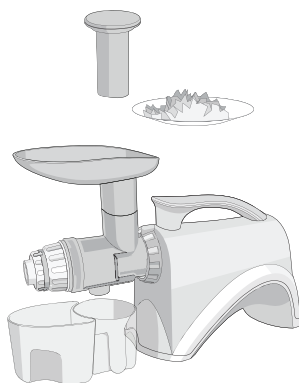

ASSEMBLY INSTRUCTIONS

Assembly 5

DO NOT place any metal objects into the hopper. If the drum set is clogged or the machine stops operating, press the reverse button 2 to 3 times which will clear the clogging and press the on button again to resume normal operation.

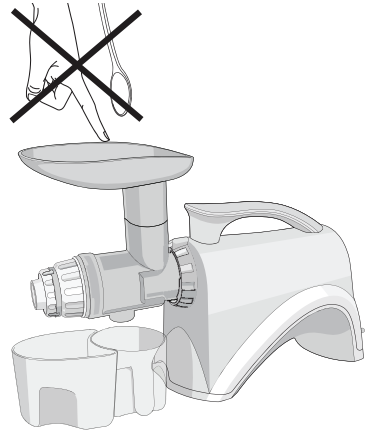

Assembly 6

Switch the juicer OFF before changing accessories or touching any moving parts. Remove the drum set from the main body by turning the locking clip counter-clock wise. Pull the auger forward to disassemble it from the drum set. After juicing wash all parts in warm soapy water. Do NOT place any of the juicer accessories in the dishwasher.

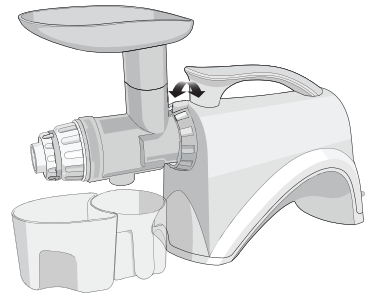

Assembly 7

DO NOT run juicer for more than 30 minutes continuously at any one time.



MAKING PASTA, U-DONG, NOODLE, BREADSTICK

Assembly 1

For processing function:

Replace juicing strainer with processing strainer

Place the desired nozzle into the front end of the processing strainer. Turn drum cap counter-clockwise until it clips firmly into place.

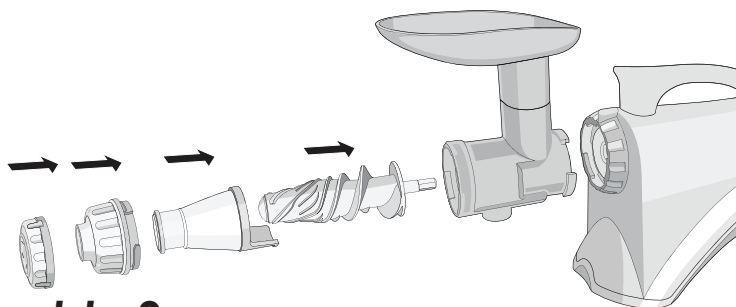

Assembly 2

Sprinkle a small amount of wheat flour on the holding dish placed under the spout.

Press ON button.

Push pasta dough through the food guide without stopping.

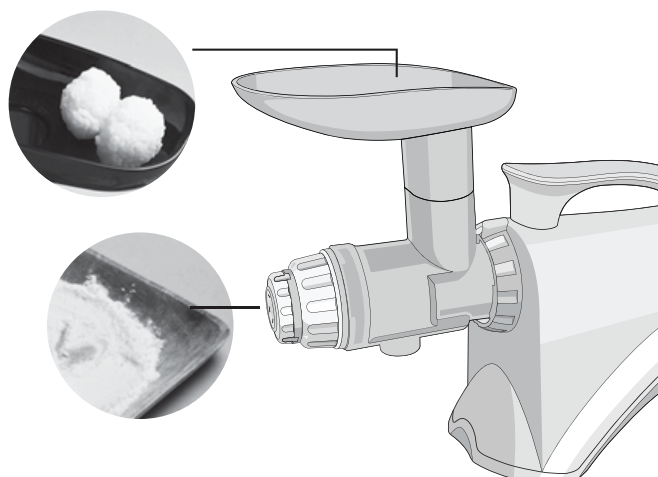

Assembly 3

Use scissors to cut the pasta to desired lengths. Cook according to recipe used.

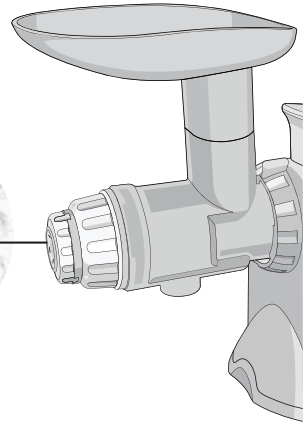

Assembly 4

Disassemble unit and rinse all parts and accessories first in cold water. Then wash in warm soapy water in your sink – NOT in your dishwasher.

Choosing the Right Strainer

MATERIAL	STRAINER
Apples, Oranges, Pears, Grapes, Strawberries, Kiwi fruit, Tomatoes, Avocados, Aloe, plant, pine tree leaves, kale, Radishes, Beet tops, (fruit) spinach, carrots, yams wheat grass.	Juicing strainer
Red/ green pepper, garlic, ginger, herbs, soaked rice and beans.	Processing strainer
Pasta, U-dong, Noodle Breadstick, Ice cream, Nut butter.	Processing strainer



OMEGA PRODUCTS, INC.
3355 ENTERPRISE AVENUE, SUITE 160
FORT LAUDERDALE, FL 33331
PHONE: 877.368.2797
FAX: 954.202.7337