



Item #555-179  
Model #FW-HUNCACHF-12

# USE AND CARE GUIDE

---

## CIBOLA CORNER ARM CHAIR



Questions, problems, missing parts? Before returning to the store,  
call Hampton Bay Customer Service  
8 a.m. - 6 p.m., EST, Monday-Friday

**1-877-527-0313**

**HAMPTONBAY.COM**

---

### THANK YOU

*We appreciate the trust and confidence you have placed in Hampton Bay through the purchase of this Cibola Corner Arm Chair. We strive to continually create quality products designed to enhance your home. Visit us online to see our full line of products available for your home improvement needs. Thank you for choosing Hampton Bay!*

# Table of Contents

Table of Contents.....	2	Assembly .....	4
Safety Information.....	2	Maintenance .....	5
Warranty .....	2	Care and Cleaning .....	6
5 YEAR FRAME / 1 YEAR FABRIC WARRANTY .....	2	Service Parts .....	8
Pre-assembly.....	3		
Package Contents .....	3		

# Safety Information



**WARNING:** Chairs have a 250 lb. weight capacity. Hang the cushion over the chair frame to dry if it gets wet to prevent mold/mildew.



**IMPORTANT:** Place the chair on a carpeted, flat surface to prevent scratching.



**NOTE:** Please read the instructions carefully and thoroughly before assembling. Check the parts against the parts list to ensure you have all the parts needed for proper assembly. Familiarize yourself with the inventory of parts and the accompanying illustrations to ensure safe and proper assembly.

# Warranty

## 5 YEAR FRAME / 1 YEAR FABRIC WARRANTY

### WHAT IS COVERED

We warrant the frame to be free of manufacturing defects to the original purchaser for five years and the fabric for one year.

### WHAT IS NOT COVERED

It remains the customer's responsibility for freight and packaging charges to and from our service center. This warranty does not cover commercial use, hardware, acts of nature, fire, freezing and abusive use. In addition, purchased parts are not covered under this warranty. We reserve the right to make substitutions with similar merchandise, if the model in question is no longer in production.

Contact Customer Care at 1-877-527-0313 or visit [www.hamptonbay.com](http://www.hamptonbay.com).

# Pre-assembly

## PACKAGE CONTENTS

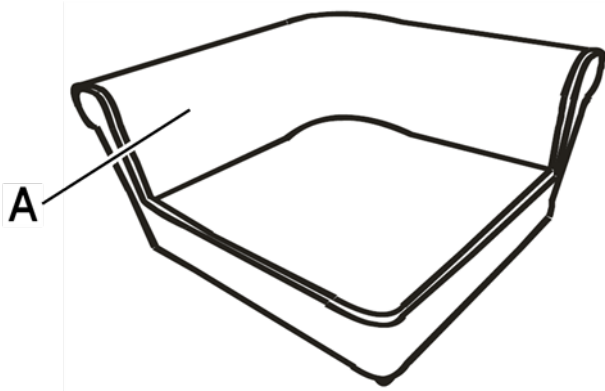

A

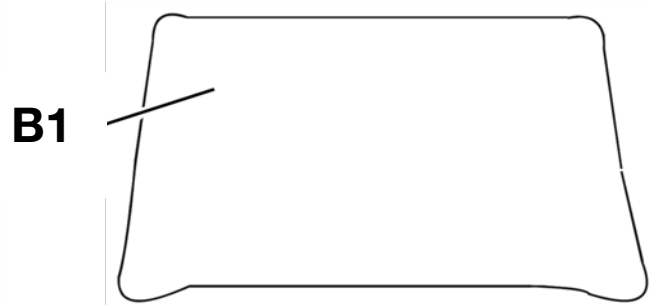

B1

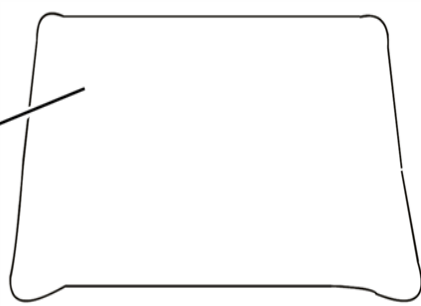

B2

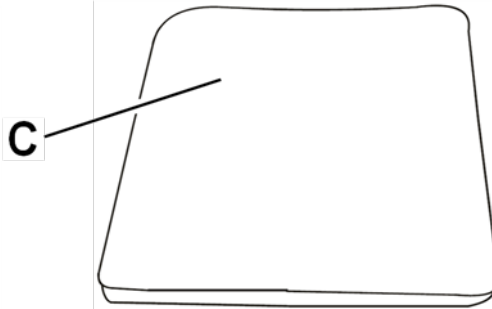

C

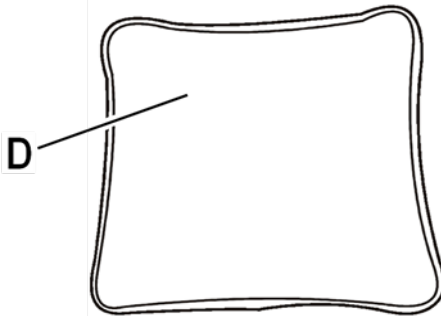

D

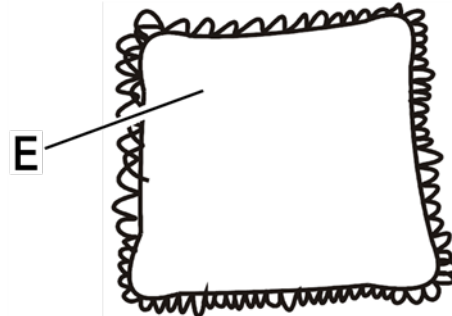

E

Part	Description	Quantity
A	Chair Frame	1
B1	Long Back Cushion	1
B2	Short Back Cushion	1
C	Seat Cushion	1
D	Throw Pillow – Flagship Baybrown with Cord	1
E	Throw Pillow –Morocco Nutmeg with Fringe	1

## Assembly

---

**1** Removing the cushions and pillows from the bottom of the chair frame

**2** Placing the cushions and pillows on the chair

## Assembly

- Carefully turn the chair frame (A) upside down on a soft surface.
- Remove the cushions (B2) and the throw pillows (D and E) from the bottom of the chair frame (A).

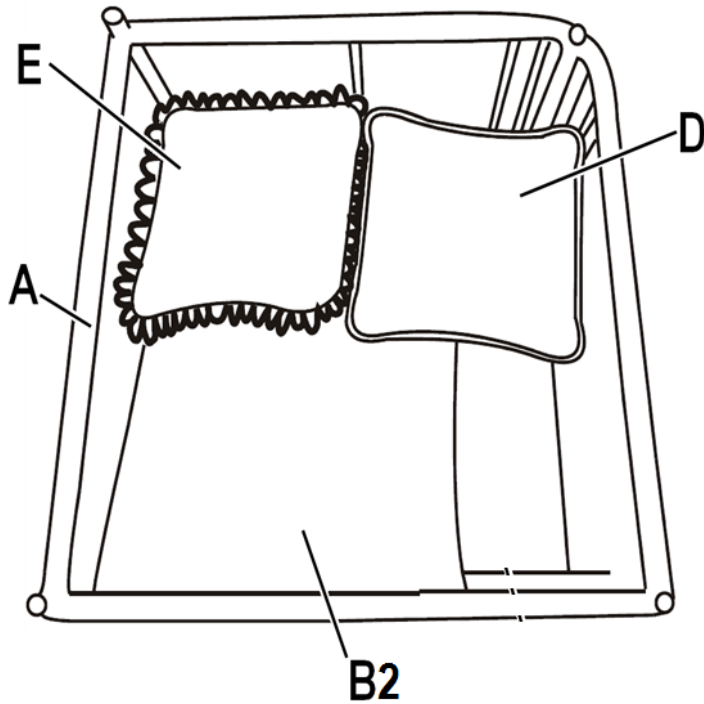

- Carefully turn the chair frame (A) to the upright position.
- Place the cushions (B1, B2 and C) and the throw pillows (D and E) on the chair frame (A).

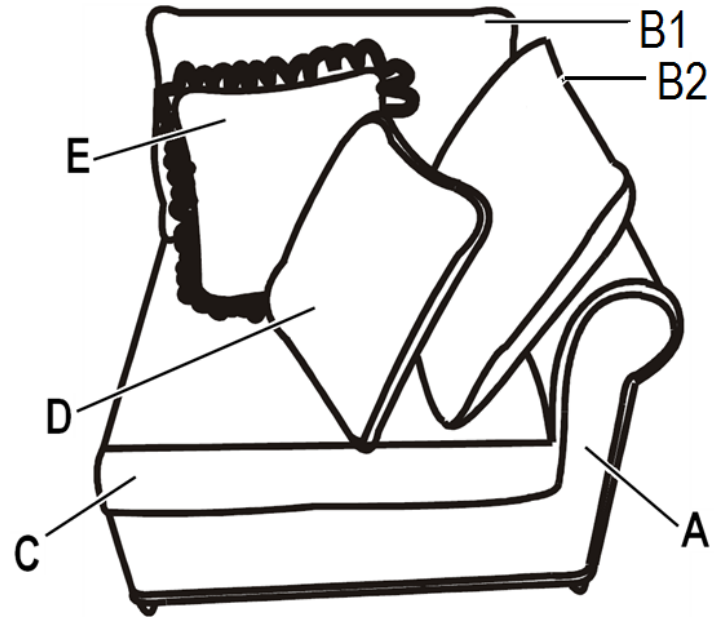

## Maintenance

## Frames

- Clean your outdoor furniture with a soft, wet towel using a mild soap and water solution.
- Dry completely with a soft towel.
- To maintain and protect your outdoor furniture, always cover it with an outdoor furniture cover or store it in a safe (covered and protected) interior area of your home when not in use for extended periods of time.



**WARNING:** Do not use bleach or strong solvents to clean any of your outdoor furniture, as it will harm the metal finish.



**CAUTION:** Caution should be used when using oils, lotions and other chemicals such as chlorine, or repeated exposure to extreme weather conditions (including heat), which may cause permanent discoloration of the frame. Caution should be used when using oils and lotions, as they can attract dirt which can harm your outdoor furniture's finish.



**NOTE:** Please note that some food items will harm your outdoor furniture's finish. Chemical spills and food spills should be removed immediately from your furniture.

## Cushions

- Store cushions in a clean, dry area of your home when not in use.
- Do not machine wash or dry the cushions.

### Sunbrella® fabric

- One of the best ways to keep Sunbrella® fabric looking good and to delay deep or vigorous cleaning is to properly maintain the fabric. This can be accomplished by simply brushing off dirt before it becomes embedded in the fabric, wiping up spills as soon as they occur, or spot cleaning soon after stains occur.
- If your Sunbrella® fabric has mildew or mold, it can be removed easily with mild soap and water. Mildew grows on dirt, pollen and other organic matter, so simple routine cleanings will prevent mildew from forming.

# Care and Cleaning

## General or light cleaning

- Brush off any loose dirt.
- Prepare a cleaning solution of 2 ounces (1/4 cup) mild soap per gallon of lukewarm water (less than 100°F/38°C).
- Use a sponge or a soft bristle brush to clean.
- Allow the cleaning solution to soak into the fabric.
- Rinse thoroughly to remove all soap residues.
- Allow the fabric to air dry completely.

## Spot cleaning

- Apply a light mist of our recommended cleaning solution using a spray bottle.
- Work the solution into the stain by lightly scrubbing the area with a sponge or very soft bristle brush.
- Rinse thoroughly to remove all soap residues.
- Blot excess moisture with a clean, soft towel or sponge.
- Wet-vacuum or blot excess water.
- Repeat these steps until the stain is removed.

## Care and Cleaning (continued)

### Heavy cleaning for stubborn stains and mildew

Sunbrella® fabric does not promote mildew growth. However, mildew may grow on dirt and other foreign substances that are not removed from the fabric. To clean mildew or other stubborn stains:

- Prepare a solution of 8 ounces (1 cup) of bleach and 2 ounces (1/4 cup) of mild soap per gallon of clean water.
- Spray on the entire area and allow it to soak into the fabric.
- Scrub vigorously with a soft bristle brush, sponge or clean towel.
- Rinse thoroughly to remove all soap residues.
- Allow the fabric to air dry.
- If the stain and/or mildew are severe, bleach quantities may be increased.



**CAUTION:** Excessive soaking in bleach can deteriorate sewing threads and other non-Sunbrella components.

Sunbrella® fabrics have a special finish that enhances water repellency. The finish is designed to last for several years of normal use, but may be refreshed after a thorough cleaning or extended use. Sunbrella® recommends 303 High Tech Fabric Guard™ as the preferred re-treatment product for Sunbrella® fabrics. For more information, please visit [www.303products.com](http://www.303products.com).

### Professional cleaners

In evaluating the services of a professional firm, you should inquire about the firm's experience in working with Sunbrella® fabrics and knowledge of cleaning and re-treatment requirements. **DO NOT** dry clean Sunbrella® fabrics.

### Helpful hints

Protect the area around your Sunbrella® fabric when using a bleach solution – bleach may discolor and/or deteriorate non-Sunbrella® fabrics. Always rinse the Sunbrella® fabric thoroughly to completely remove the bleach. Sunbrella® fabric air-dries very quickly. Machine drying is not necessary and may damage the fabric. If the fabric has some wrinkling, use an iron, if necessary, but only on the synthetic setting. As some irons exceed the recommended 100°F/38°C temperature on the synthetic setting, test a small inconspicuous area before ironing the entire piece. **DO NOT** use a steamer or iron set to steam setting.

# Service Parts

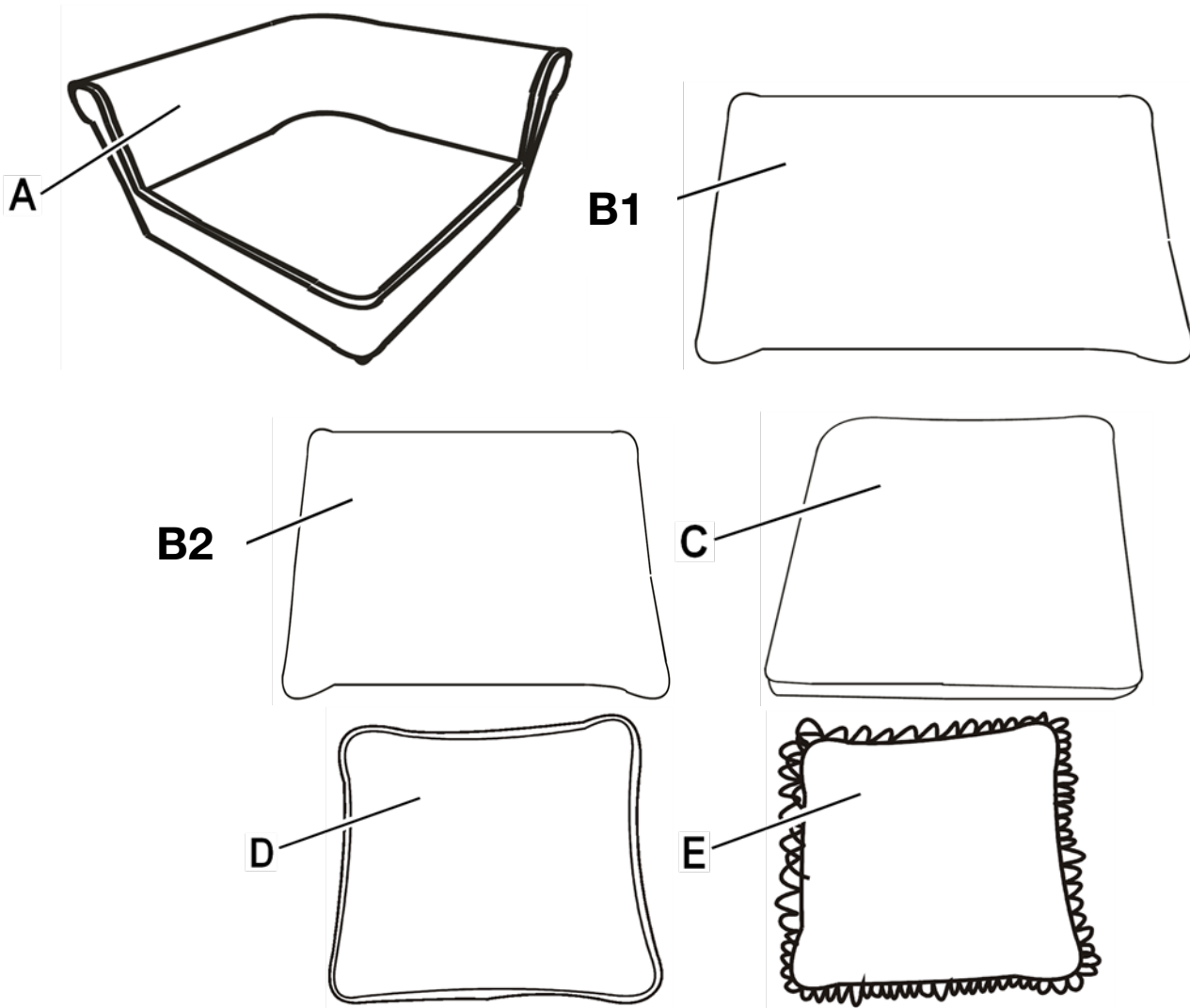

Part Number	Description
PF-555179-A-HD12	Chair Frame
PF-555179-B1-HD12	Long Back Cushion
PF-555179-B2-HD12	Short Back Cushion
PF-555179-C-HD12	Seat Cushion
PF-555175/179-D-HD12	Throw Pillow Morocco Nutmeg with Cord
PF-555175/179-E-HD12	Throw Pillow Flagship Baybrown with Fringe





Questions, problems, missing parts? Before returning to the store,  
call Hampton Bay Customer Service  
8 a.m. - 6 p.m., EST, Monday-Friday

**1-877-527-0313**

**HAMPTONBAY.COM**

Retain this manual for future use.