



MM-B80

MINI BIKE

OWNER'S MANUAL

THIS OWNER'S MANUAL CONTAINS IMPORTANT INFORMATION.
READ THOROUGHLY BEFORE RIDING FOR THE FIRST TIME.



MINI BIKE

MM-B80



OWNER'S MANUAL

Monster Moto

1001 South Jupiter Road | Garland, TX 75042 | 855-833-6483
info@monstermoto.com | www.monstermoto.com



**IF YOU HAVE PROBLEMS, DO NOT RETURN TO STORE!
CONTACT MONSTER MOTO AT 855-833-6483
OR INFO@MONSTERMOTO.COM!**

Failure to follow the instructions in this manual could result in serious injury or death. Failure to follow the instructions in this manual could also prevent the mini bike from operating properly.

This owner's manual contains important information. Each rider of the mini bike must read this owner's manual thoroughly before riding the mini bike for the first time and must always follow all of the instructions outlined in this manual. This manual must remain with the vehicle if the vehicle is transferred to a new owner. Do not discard this owner's manual as it must be reviewed by each rider prior to his or her operation of the vehicle. If a minor is operating the vehicle, it is the responsibility of the minor's guardian to ensure that the minor understands the information contained in this manual.

This manual contains the latest product information available before printing. You may view the most recent version of this owner's manual online at www.monstermoto.com. Due to product improvements or production changes, there could be discrepancies between the information contained in this owner's manual and actual product specifications. Monster Moto reserves the right to make changes to its products at any time without notice and without obligation to make the same or similar changes to any vehicle previously built or sold.

© Monster Moto, LLC

No part of this publication may be reproduced or copied without written permission from Monster Moto.

TABLE OF CONTENTS

Introduction	3
Laws & Regulations	4
Maintenance Requirements.....	4
Safety	5
Getting Started: Assembling & Breaking In The Mini Bike.....	7
Basic Operation: Starting, Riding, Stopping & Storing The Mini Bike	9
Maintenance Procedures	12
Fuel	12
Engine Oil.....	15
Air Filter.....	17
Brakes.....	18
Tires.....	19
Drive Chain.....	20
Appearance & Care	21
Troubleshooting.....	22
Warranties.....	24
Limited Warranty.....	25
Emissions Control Warranty	25
Specifications.....	26
Registration	28

INTRODUCTION

Congratulations on the purchase of your new Monster Moto MM-B8o! We hope that your new mini bike provides years of fun experiences and epic moments. Monster Moto is dedicated to providing you with an exceptional experience. If you are not happy with your mini bike, don't return it! Instead, contact Monster Moto at 855-833-6483 or info@monstermoto.com, and we will do our best to provide you with outstanding customer support.

Since owning a mini bike requires regular maintenance and upkeep, the information contained in this owner's manual will be understood best by our customers who are mechanically inclined. If you ever have questions about servicing or maintaining your mini bike, do not hesitate to reach out to Monster Moto customer service for help. Our goal is to provide you with a seamless ownership experience! When contacting Monster Moto customer service, please have your vehicle identification number (VIN) and engine number handy to help us best assist you. See page 9 for help locating your mini bike's VIN and engine number.

Below is a list of resources which we believe you will find helpful as a mini bike owner:

- » **Warranty Information:** Your mini bike is covered by a limited warranty and an emissions control system warranty. Please see the *Warranties* section of this owner's manual for complete warranty information. If you would like to submit a warranty claim, please contact Monster Moto customer service.
- » **Maintenance Resources:** A library of instructional maintenance videos is available for you to view online at www.monstermoto.com. In addition to this manual, you may reference the maintenance videos for step-by-step instructions outlining how to perform basic maintenance procedures on your MM-B8o.
- » **Replacement Parts:** If you would like to order replacement parts for your vehicle, contact Monster Moto customer service. A parts list is not contained in this owner's manual. Visit www.monstermoto.com to view the most recent parts list for the MM-B8o.
- » **Service Centers:** In the instance that you have a problem with your mini bike and need to have it serviced, visit www.monstermoto.com to find an Authorized Monster Moto Service Center near you. If you cannot find one, please contact Monster Moto customer service and we will find one to suit your needs.

Congratulations again on your purchase, and we hope you enjoy your mini bike for many years to come!

Happy Trails,

Your friends at Monster Moto

LAWS & REGULATIONS

It is the responsibility of any rider of this vehicle to be familiar with and fully comply with all laws, rules, and regulations governing the operation of this vehicle. Laws vary by jurisdiction. Monster Moto has no responsibility or liability for the costs to comply with all applicable laws and regulations or for mini bike damage or human injury resulting from an owner or operator's failure to follow all relevant laws and regulations. These laws include, but are not limited to:

- » **Vehicle Operation Laws:** It is illegal to operate this off-road vehicle on public streets, roads, and highways. It is illegal to operate this vehicle under the influence of drugs or alcohol, even on private property. Other vehicle operation laws might apply in your area.
- » **Vehicle Title & Registration Laws:** You may need to title and/or register your new mini bike with one or more state or municipal government agencies. You are solely responsible for titling and/or registering your mini bike and for all related costs. Keep your mini bike's Certificate of Origin; it may be required to title and/or register your vehicle.
- » **Vehicle Modification Laws:** Do not modify your mini bike or attach after-market accessories. Modifications to the carburetor and exhaust systems are a violation of the law and are subject to prosecution by the Environmental Protection Agency.
- » **Vehicle Maintenance Laws:** Always follow all relevant vehicle maintenance laws, which include, but are not limited to, laws regulating the handling and disposal of flammable and dangerous materials such as gasoline and oil.

MAINTENANCE REQUIREMENTS

Maintenance requirements are a normal part of owning and operating a mini bike. The operator of the mini bike is responsible for properly maintaining the vehicle and for understanding when and how the mini bike must be serviced. The exact timing in which maintenance procedures must be performed will vary based on the type of maintenance, riding conditions, and riding frequency. The maintenance procedures outlined in this manual are simply guidelines for how and when to perform basic maintenance procedures. Other than the procedures referenced in this manual, there are many other more complicated maintenance procedures which will need to be performed on your mini bike during your ownership of the product.

Failure to properly maintain your vehicle could prevent the mini bike from operating properly and could also result in harm or fatal injury to the rider or others. Monster Moto has no responsibility or liability for the costs to properly maintain the vehicle (unless explicitly covered by warranty) or for mini bike damage or human injury resulting from an owner or operator's failure to service and maintain the mini bike properly.

SAFETY

The MM-B80 mini bike has the potential to cause serious injury or death.

Although the risks associated with riding a mini bike can never be eliminated completely, following all of the instructions contained in this manual will reduce the risk of harm to the operator and others. Any rider of the mini bike must always review and follow the instructions outlined in this manual. It is not possible to warn the mini bike owner or operator of all possible hazards associated with operating and maintaining a mini bike. All operators must exercise good judgment in operating and maintaining the vehicle. Monster Moto has no responsibility or liability for mini bike damage or human injury resulting from an owner or operator's failure to safely operate or service the vehicle.

⚠️ WARNING: Never allow children under the age of 16 to ride the mini bike.

The mini bike is designed for riders who are 16 or older. Riders younger than age 16 should not operate the mini bike.

⚠️ WARNING: Never allow unsupervised or unqualified minors to ride the bike.

If the operator of the mini bike is a minor, the rider's guardian is responsible 1) for ensuring that the rider meets the physical and developmental levels necessary to safely ride the bike and 2) for supervising the minor while he or she is riding the mini bike.

⚠️ WARNING: Always wear protective safety gear while riding the mini bike.

Protective safety gear includes, but is not limited to, a Department of Transportation approved full-face motorcycle helmet with a chin strap, goggles, boots, gloves, long riding pants with hip and knee pads, and a long sleeved riding jersey with elbow, chest, and shoulder pads.

⚠️ WARNING: Always secure hair while riding the mini bike.

Loose hair has the potential to get caught in the mini bike. Always keep hair tightly secured while operating the bike.

⚠️ WARNING: Never operate the bike under the influence of alcohol or drugs.

The use of alcohol and/or drugs will impair the rider's ability to safely operate the mini bike.

⚠️ WARNING: Never operate the mini bike with a passenger.

The mini bike is designed for one rider at a time.

⚠️ WARNING: Never ride the mini bike on hard surfaces.

The mini bike's tires are designed for operation in dirt, gravel, or similar materials and are not stable on any hard surfaces including, but not limited to, concrete or asphalt.

⚠️ WARNING: Never ride the mini bike at night.

The mini bike is not equipped with lights.

⚠️ WARNING: Never ride the mini bike alone.

Because unexpected situations can occur, always ride in proximity of your base and of other people who can provide assistance in case of a problem.

PROBLEMS? DO NOT RETURN TO STORE! CALL US AT

⚠ WARNING: Never ride the mini bike if it is not in proper riding condition.

Always inspect your mini bike before you ride to ensure that it is in proper riding condition. If you have any indication that your mini bike is not running correctly, stop riding immediately. Do not ride your mini bike back to your base. Find another method of transportation. Once you are back to safety, refer to the *Maintenance Procedures* and *Troubleshooting* sections of this manual to service your mini bike.

⚠ WARNING: Always exercise good judgment while riding the mini bike.

It is the responsibility of the operator of the mini bike to use sound judgment in the operation and use of the vehicle. Ride within your skill level at comfortable speeds. Be cautious of potential hazards and difficult terrain. Exercise extra caution in muddy or wet riding conditions. Always keep both hands and feet on the handlebars and foot pegs. Do not brake or accelerate while turning. Do not attempt tricks or stunts or go off jumps.

⚠ WARNING: Never operate the mini bike in an enclosed space with poor ventilation.

The mini bike's exhaust gas contains poisonous carbon monoxide which can collect rapidly in an enclosed area and result in illness or death.

⚠ WARNING: Never modify the mini bike or attach after-market accessories.

Modifications and after-market accessories reduce the rider's ability to control and ride the mini bike safely. Monster Moto is not liable for any damage or injury caused by any after-market accessory.

⚠ WARNING: Always perform the necessary maintenance on the vehicle.

Failure to perform necessary maintenance on the vehicle could result in harm or fatal injury to the operator or others.

⚠ WARNING: Always exercise caution while servicing the mini bike.

Performing most maintenance procedures on the mini bike involves handling potentially dangerous and flammable materials such as oil and gasoline. Recognize the risk that injury could potentially occur while you are servicing your mini bike and always use good judgment. Wear the necessary protective gear. Keep flames and cigarettes away from the mini bike. If you are uncomfortable with the risks, refer to an Authorized Monster Moto Service Center to perform maintenance tasks for you.

⚠ WARNING: Never perform maintenance on the vehicle while it is running.

To reduce the risk of potential harm or burns from hot or moving parts, always ensure that the engine stop switch and the fuel valve lever are both in the "off" position before performing maintenance on your mini bike. Never touch any of the mini bike's parts while the mini bike is running.

⚠ WARNING: Always wash hands after handling the mini bike.

Certain components of this product and package contain chemicals known to the State of California to cause cancer, birth defects, or other reproductive harm.

GETTING STARTED: ASSEMBLING & BREAKING IN THE MINI BIKE

After the mini bike has been removed from the cardboard shipping box, a protective metal frame will be exposed.

REMOVING THE PROTECTIVE METAL FRAME

1. Unscrew the two handlebar bolts holding the mini bike to the metal frame.
2. Unscrew the metal frame's four corner bolts. Removal of the corner bolts will allow the top of the metal frame to be removed.
3. Remove the top of the metal frame to expose the mini bike.
4. Unscrew the two frame bracket bolts and rest the mini bike on its extended kickstand.
5. Wheel the mini bike from its protective frame to continue assembly.

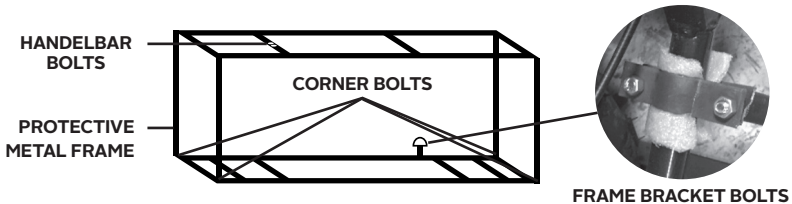

ASSEMBLING YOUR MINI BIKE ATTACHING THE FRONT PLATE

1. Park your mini bike on a firm, level surface.
2. Locate the front plate, which was included in the mini bike parts bag.
3. Remove the two screws and two washers from the front plate brackets.
4. Using the washers and screws removed in step 2, mount the front plate to the front plate brackets.

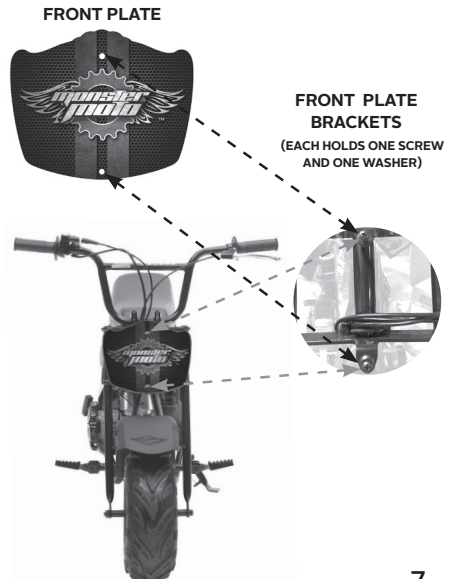

PROBLEMS? DO NOT RETURN TO STORE! CALL US AT

ATTACHING THE HANDLEBARS

1. Park your mini bike on a firm, level surface.
2. Locate the handlebar assembly hardware, which was included in the mini bike parts bag.



2. The diagram below illustrates how to attach the mini bike's handlebars to the mini bike.

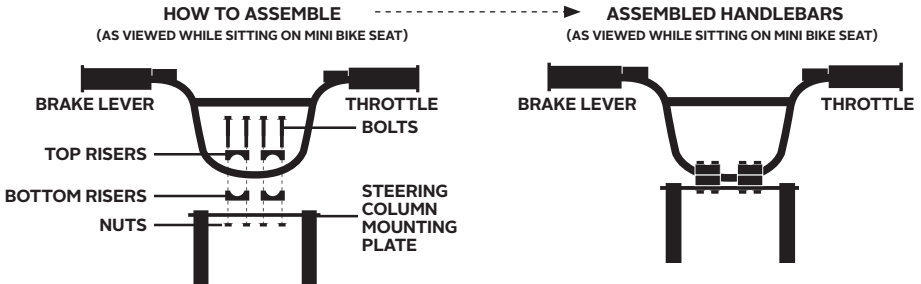

3. Once the handlebars are attached according to the diagram above, sit on the mini bike to ensure the handlebars are in an appropriate position. Tighten the bolts when you are comfortable with the placement of the handlebars. Do not overtighten.

GETTING YOUR MINI BIKE READY TO RIDE

1. Remove the twine holding up the mini bike's foot pegs.
2. Your mini bike will come with engine oil either already in the engine or in a separate bottle included in the box. Check the engine oil level and add oil if necessary. Do not ride the mini bike until the oil is at the appropriate level.
3. Add gasoline to the fuel tank.
4. Learn more about how to start, ride, stop, and store your mini bike in the *Basic Operation* section of this manual.

BREAKING IN YOUR MINI BIKE

To protect your new engine, enjoy optimum performance, and extend the life of the vehicle, break in your mini bike properly. To do this, avoid full throttle starts and rapid acceleration for the first fifteen miles.

BASIC OPERATION: STARTING, RIDING, STOPPING & STORING THE MINI BIKE



CHOKE LEVER
(LEFT IS RUN/RIGHT IS START)



FUEL VALVE LEVER
(LEFT IS OFF/RIGHT IS ON)



PULL STARTER CORD



VEHICLE IDENTIFICATION NUMBER

(ETCHED INTO METAL PLATE ON BOTTOM OF MINI BIKE)

ENGINE NUMBER

(ETCHED INTO OIL TANK)



THROTTLE

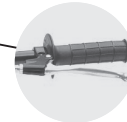

REAR BRAKE LEVER

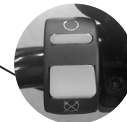

ENGINE STOP SWITCH

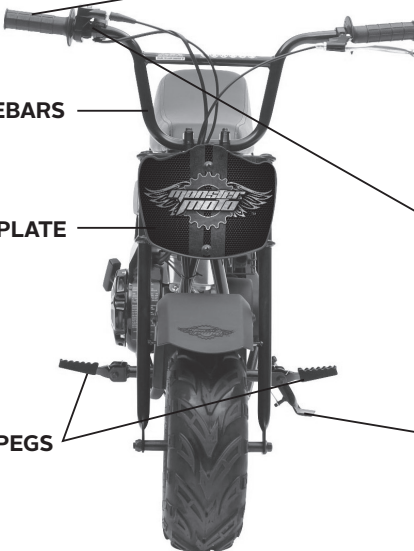

HANDLEBARS

FRONT PLATE

FOOT PEGS



KICKSTAND

INSPECTING YOUR MINI BIKE

Before turning on and riding your mini bike, inspect the vehicle to ensure it is in proper operating condition:

- » Examine the tires for proper inflation and to detect excessive wear.
- » Visually inspect the entire mini bike for damage.
- » Check the engine oil level and the fuel level, and ensure that the fuel cap and the oil filler cap are securely tightened.
- » Test to ensure that the brakes and the throttle are working properly.
- » Visually inspect the mini bike for fuel or oil leaks.
- » Inspect all nuts and bolts to ensure they are properly tightened.
- » Ensure that the handlebars move smoothly.
- » Complete any maintenance procedures which are necessary to ensure your mini bike is in proper riding condition. Do not ride your mini bike if it is not in operating condition. Refer to the *Troubleshooting* section of this manual or call Monster Moto customer service to remedy any problems you find.

STARTING YOUR MINI BIKE

1. Turn the engine stop switch to the “on” position, as indicated by the  symbol.
2. Turn the fuel valve lever to the “on” position.
3. Ensure that the choke lever is in the correct position:
 - a. If the engine is warm, move the choke lever into the “run” position.
 - b. If the engine is cold, move the choke lever into the “start” position.
4. Pull the pull starter cord in rapid succession until the engine starts running. To avoid potential damage to your mini bike, never pull the starter cord all the way out of its housing.
5. Once the engine has started, move the choke lever into the “run” position if it was not already there. Having the choke lever in the “start” position will help you start the mini bike; however, the mini bike will not operate properly with the choke lever in the “start” position. Always move the choke lever to the “run” position once the engine is running.
6. Once the choke lever is in the “run” position, use your foot to disengage the kickstand and you are ready to ride!
7. If the mini bike stops running after you move the choke lever into the “run” position, repeat the steps above to restart the engine, this time allowing the engine to idle with the choke lever in the “start” position for one to two minutes before you move the choke lever into the “run” position. This will allow the engine to achieve a higher operating temperature.

RIDING YOUR MINI BIKE

- » **To Go:** The speed of the mini bike is controlled by the throttle. Twisting the throttle towards the rider increases the speed of the mini bike and releasing pressure from the throttle causes the mini bike to gradually slow down until it comes to a stop. When the throttle is twisted towards the rider and the mini bike is moving, the throttle is “open.” When the throttle is in its resting position, it is “closed.”
- » **To Stop:** To stop or slow the mini bike, release the throttle and squeeze the rear brake lever firmly and smoothly. The more braking pressure you apply, the quicker you will slow down and stop. When you come to a stop, put your foot down to balance the mini bike.

STOPPING YOUR MINI BIKE

1. When you have finished riding, use your foot to lower the kickstand. The kickstand will keep the mini bike upright when it is parked.
2. Turn the engine stop switch to the “off” position, as indicated by the  symbol. Turning the engine stop switch off while the mini bike is running will stop the mini bike immediately.
3. Turn the fuel valve lever to the “off” position.

STORING YOUR MINI BIKE

Store the mini bike on a flat surface, preferably sheltered from the elements. Storing the mini bike in the sun, wind, rain, or snow or in similar conditions will potentially reduce the lifespan of the vehicle.

If you will not be using the mini bike for an extended period of time, stop the mini bike by turning the fuel valve lever into the “off” position and allowing the mini bike to stop on its own. This uses up the fuel that remains in the carburetor and protects the carburetor from gasoline varnish, a problem that can arise when your mini bike is stored for long periods of time.

MAINTENANCE PROCEDURES

FUEL



- 1. FUEL FILTER**
- 2. FUEL FILTER CLAMP**
- 3. FUEL LINE**



- 1. CARBURETOR SEDIMENT CUP**
- 2. CARBURETOR DRAIN SCREW**
(THE SCREW ON THE SIDE OF THE CUP, NOT DIRECTLY ON THE BOTTOM OF THE CUP)



- FUEL TANK**

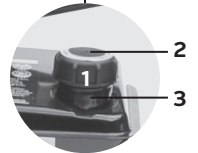

- 1. FUEL CAP**
- 2. FUEL CAP VENT**
(SMALL HOLE ON TOP OF FUEL CAP)
- 3. FUEL FILLER NECK**

ADDING FUEL

Before each ride, check the mini bike's fuel level and add fuel if necessary. Use any unleaded gasoline with an octane rating of 87 or higher in your mini bike. Never use ethanol blended fuel, stale or contaminated fuel, or fuel that has been mixed with oil. Follow the steps below to refuel your mini bike:

1. Park the mini bike on a firm, level surface and turn the engine stop switch to the "off" position.
2. Unscrew the fuel cap and remove the cap from the fuel tank.
3. Add fuel to the tank. The tank is full when the fuel level reaches the bottom of the fuel filler neck.
4. Screw the fuel cap back onto the fuel tank and tighten it securely.
5. Using a cloth, wipe away any spilled fuel.

REMOVING SEDIMENT FROM THE FUEL SYSTEM

Avoid getting dust, dirt, water, and/or debris in the fuel tank. If the fuel tank has become contaminated, it will need to be drained and new fuel will need to be added. Certain fuel system components will also need to be cleaned. Follow the steps below to remove contamination from the fuel system:

1. Park the mini bike on a firm, level surface and turn the engine stop switch to the "off" position.
2. Turn the fuel valve lever to the "on" position.
3. Locate a secondary container, such as a plastic bucket, to catch the gasoline that you will drain from the tank.
4. Take a pair of pliers and release the pressure on the fuel filter clamp that holds the fuel line and the fuel filter together.
5. Pull the fuel line off of the fuel filter and let the gasoline flow through the fuel filter into the secondary container. If no fuel drains, your fuel filter might be clogged. With a wrench, remove the fuel filter so gasoline can flow directly from the tank into the secondary container.
6. Drain the entire tank.
7. If you have not already done so in step 3 above, use a wrench to remove the fuel filter.
8. Clean the filter thoroughly to remove all debris.
9. If you notice excessive debris in the drained fuel or in the fuel filter, you will need to run additional fuel through the tank to clear out any remaining debris. Add gasoline to the tank, letting it flow through the tank and into the secondary container. Continue adding fuel until no debris remains in the tank.
10. Screw the fuel filter back into the fuel tank.
11. Attach the fuel line to the fuel filter and secure the fuel filter clamp back into its original position.
12. Refuel with fresh gasoline.
13. If sediment has been found in the fuel tank, you will also need to clean the carburetor sediment cup. Unscrew the carburetor drain screw. Let the gasoline flow into a secondary container until the fuel flows clean. Reinsert the carburetor drain screw.
14. If necessary, add additional fuel to the tank to replace the fuel you drained in step 11.
15. Use a cloth to wipe away any gasoline that spilled on or around the mini bike.
16. Start the mini bike and visually examine the fuel system for leaks before riding.

CLEARING A FLOODED ENGINE

If the engine fails to start after repeated attempts, it may be flooded with excess fuel. Follow the steps below to clear a flooded engine:

1. Park the mini bike on a firm, level surface and turn the engine stop switch to the “off” position.
2. Turn the fuel valve lever into the “off” position.
3. Push the choke lever into the “run” position.
4. Twist the throttle and hold it in the “open” position.
5. Firmly grip the pull starter cord and pull in rapid succession for about 30 seconds. This step clears excess fuel from the engine.
6. Turn both the engine stop switch and the fuel valve lever to the “on” position, and start your mini bike with the choke lever in the “run” position.

CLEANING THE FUEL CAP VENT

If the mini bike is not starting or is not performing well, you might have a clogged or partially obstructed fuel cap vent. Park the mini bike on a firm, level surface and turn the engine stop switch to the “off” position. Remove the fuel cap to allow air into the fuel tank and then screw the fuel cap back onto the fuel tank. Try starting the engine. If the engine starts after air has been let into the tank, the fuel cap vent is probably clogged. To remedy the problem, clean dirt and debris from the fuel cap vent.

ENGINE OIL

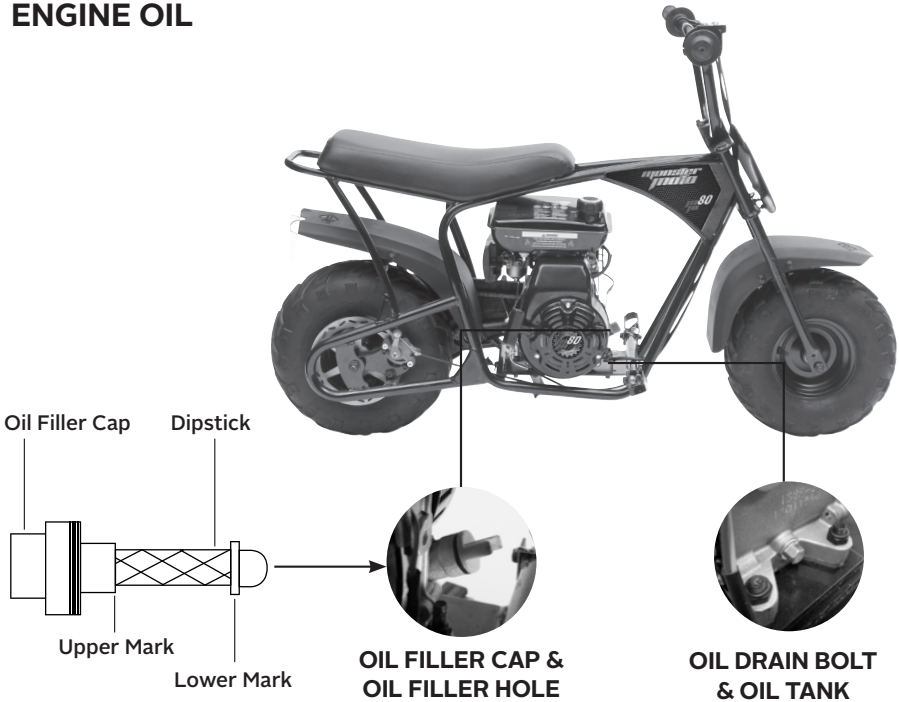

CHECKING & ADDING ENGINE OIL

Before each ride, check the mini bike's engine oil level and add oil if necessary. The Society of Automotive Engineers (SAE) 10W-30 oil is recommended for most climates. If you live in an extreme climate, refer to an SAE approved oil viscosity chart to determine the appropriate type of engine oil for your environment. Follow the steps below to check and add oil:

1. Park the mini bike on a firm, level surface and turn the engine stop switch to the "off" position.
2. Use a clean cloth to wipe on and around the oil filler cap.
3. Unscrew and remove the oil filler cap.
4. Wipe the entire dipstick clean using a clean cloth.
5. Hold the mini bike upright so that it is not resting on the kickstand.
6. Insert the oil filler cap back into the oil filler hole until it rests, but do not screw it in.

PROBLEMS? DO NOT RETURN TO STORE! CALL US AT

7. Remove the oil filler cap and check for dark-colored oil on the dipstick. If the oil level is at or near the upper mark, you do not need to add oil. If the oil level is at or near the lower mark, continue to step 8.
8. Pour oil into the oil filler hole. Repeat steps 4 through 8 until the oil reaches the correct level. Do not overfill the oil tank.
9. Reinsert the oil filler cap and screw it in tightly.
10. Start the mini bike and let it run for several minutes.
11. Stop the mini bike and repeat the steps above to ensure that the oil is still at the correct level.
12. Once the oil level is correct, start your mini bike and check for oil leaks. If you see oil leaking out of the oil tank, tighten the oil filler cap and the oil drain bolt.

CHANGING THE ENGINE OIL

Change the engine oil in your mini bike as part of your regular maintenance routine. The frequency in which you will need to change the oil depends on how often you ride and the riding conditions; however, Monster Moto recommends changing the oil at least every six months and potentially more if you ride frequently in dusty environments. Follow the steps below to change the engine oil:

1. Park the mini bike on a firm, level surface.
2. Start your mini bike and let it run for five to ten minutes to warm up the engine oil.
3. Stop your mini bike by turning the engine stop switch to the “off” position.
4. Place a device, such as an oil drain pan, under the oil drain bolt to catch the used oil.
5. Using a wrench, unscrew and remove the oil drain bolt to start draining the oil.
6. After the oil has drained, lift up the mini bike from the rear frame to ensure all oil has drained from the engine.
7. After all oil has drained, screw in the oil drain bolt firmly but do not overtighten.
8. Refill the oil tank to the proper level. The oil tank capacity is twelve ounces.
9. Dispose of the waste oil at a government certified oil drop off location. Failure to do so is harmful to the environment and illegal in most states.

AIR FILTER



**AIR FILTER
COVER**



**AIR FILTER
HOUSING TAB**



AIR FILTER
(AIR FILTER COVER HAS BEEN REMOVED)

CLEANING THE AIR FILTER

The mini bike's air filter must be clean in order for the mini bike to operate properly. Inspect the air filter in your mini bike as part of your regular maintenance routine and clean it whenever it appears dirty. Follow the steps below to clean the air filter:

1. Park the mini bike on a firm, level surface and turn the engine stop switch to the "off" position.
2. Using a hard metal object like a key or the end of a tool, firmly press down on the tab that secures the air filter cover. See the air filter housing tab image above for the tab's precise location. Once you press hard enough, the air filter cover will pop off, exposing the sponge-like air filter.
3. Remove the air filter from the housing that holds it in place.
4. Wearing gloves and eye protection, dampen the air filter using a specialized air filter cleaner or a non-flammable solvent.
5. Squeeze the excess cleaner from the air filter, taking care to not damage the filter.
6. Allow filter to dry completely.
7. Wearing gloves and eye protection, dampen the air filter using a quality air filter oil.
8. Squeeze the excess oil from the air filter, taking care to not damage the filter.
9. Reinstall the air filter and the air filter cover.

BRAKES

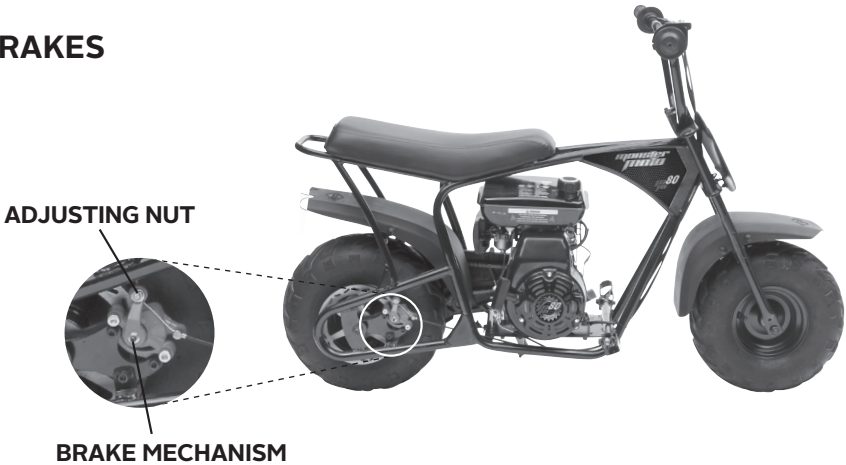

ADJUSTING THE BRAKES

If you cannot stop your mini bike properly, you will most likely need to adjust its rear disc brake. You will also need to adjust the brake as part of your regular maintenance routine, as regular use of the mini bike will cause the brake to loosen over time. Follow the steps below to complete a brake adjustment:

1. Park the mini bike on a firm, level surface and turn the engine stop switch to the "off" position.
2. Using a wrench, loosen the adjusting nut.
3. Pivot the brake mechanism toward the front of the mini bike until there is a very small amount of tension on the pivot arm. This is the optimal position for your brake. Do not rotate the brake mechanism as far forward as it can go, as this will cause your brake to be constantly engaged.
4. Using a wrench, tighten the adjusting nut.
5. Carefully lift up the back of the bike while holding the remainder of the bike steady. Do not apply the brake lever. Spin the back wheel to ensure that it spins freely. If it does not spin freely, repeat steps 1 through 4 above. This time, do not rotate the brake mechanism so far forward.
6. Lower the mini bike back to the ground and apply the brake lever. Without starting the mini bike, try to roll it forward. If the back wheel does not rotate, your brakes are properly adjusted. If the back wheel is still spinning (even slightly), repeat steps 1 through 5 above. This time, rotate the brake mechanism farther towards the front of the mini bike.

TIRES

INSPECTING YOUR TIRES

Regularly perform an in-depth inspection of your tires as part of your maintenance routine. Park the mini bike on a firm, level surface and turn the engine stop switch to the “off” position. Look for bumps or bulges in the sidewall of the tire and inside of the treads. Look closely for cuts, slits or cracks. Check for signs of excessive wear. Check for rocks, screws, nails or other objects embedded in the tires or tread. Replace all tires before the tread depth gets below .12 inches or anytime you notice a reduction in traction. Remove any foreign objects. Replace any tire if you can see a fabric or cord showing through or if there are any bumps or bulges.

Inspect your rims. If you notice the rims are bent or dented, take your mini bike to the nearest Authorized Monster Moto Service Center. Never ride with a bent or dented rim.

ADDING AIR TO YOUR TIRES

The mini bike's tires should be inflated to 15 psi in order for the mini bike to operate properly. As part of your regular maintenance routine, use a tire pressure gauge to check the air pressure in both of the tires. If necessary, use a hand pump or an electric air pump to inflate the tires to the recommended level. Always check the air pressure when your tires are cold. If you check the air pressure when the tires are warm, you will receive an artificially high reading. Never check or add air to your tires while the mini bike is running.

REPAIRING YOUR TIRES

Your mini bike has tubeless tires. If your tire has been damaged, take it to an Authorized Monster Moto Service Center to have it repaired immediately. If the tire is damaged beyond repair, please call us at 855-833-6483 or email us at info@monstermoto.com to purchase a replacement tire. Monster Moto will also help direct you to an Authorized Monster Moto Service Center who can install the replacement tire for you.

DRIVE CHAIN

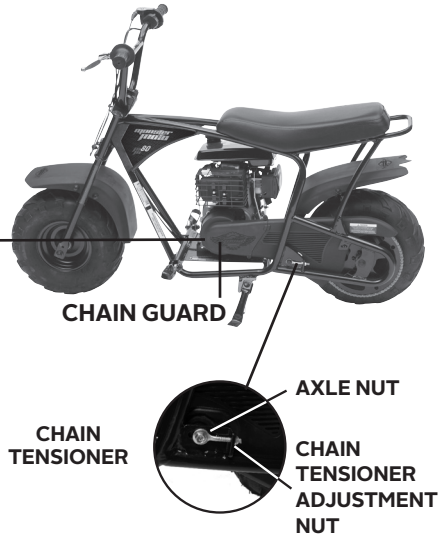
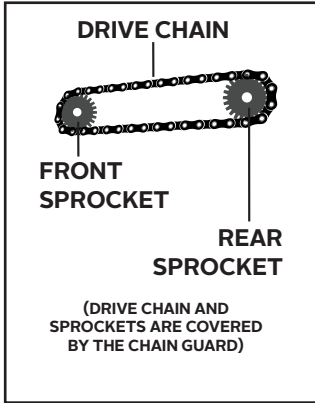

ADJUSTING THE DRIVE CHAIN

The drive chain needs to have a small amount of slack to operate properly. No slack or excessive slack in a drive chain can cause damage to the bike. Normal use of the mini bike will cause the chain to stretch over time, therefore it is necessary to adjust the tension on the chain as part of routine maintenance. Follow the following procedure to adjust the drive chain slack:

1. Park the mini bike on a firm, level surface and turn the engine stop switch to the "off" position.
2. Reach over the top of the chain guard and pull upward on the drive chain midway between the sprockets. The vertical movement of the drive chain should measure approximately $1/2$ of an inch.
3. Repeat the previous step along several points of the drive chain. The slack should remain constant throughout. If it does not, follow the steps below to make an adjustment.
4. Loosen both the axle nut and the chain tensioner adjustment nut.
5. Slide the axle nut either forwards (towards the front of the bike) to tighten the drive chain or backwards (towards the back of the bike) to loosen the drive chain. Repeat until there is approximately $1/2$ of an inch drive chain slack.
6. Tighten the axle nut and the chain tensioner adjustment nut.
7. If the chain tensioner is as tight as possible and slack still remains, the chain is worn beyond its service limit. Contact Monster Moto customer service for assistance or take your mini bike to an Authorized Monster Moto Service Center.

LUBRICATING THE DRIVE CHAIN

The drive chain needs to be properly lubricated in order for the mini bike to operate properly. Normal use of the mini bike will cause the chain to dry and rust over time, therefore it is necessary to lubricate the chain as part of routine maintenance. Follow the steps below to lubricate the drive chain:

1. Park the mini bike on a firm, level surface and turn the engine stop switch to the “off” position.
2. Using chain lubricating oil or any lightweight lubricating oil, apply oil to the drive chain visible on the rear sprocket with either a spray on applicator or an oil can. Take a rag and wipe off any excess oil with a rag.
3. Rotate the rear tire until there is a new length of the drive chain visible on the rear sprocket. Repeat step 2 above to lubricate the new length of the drive chain.
4. Repeat steps 2 and 3 until you are comfortable that the entire drive chain has been lubricated.

APPEARANCE & CARE

You may clean your mini bike using water, mild neutral detergents, and/or mild spray cleaners. Avoid using products that contain harsh detergents or chemical solvents that can damage the mini bike's metal, paint, and plastic. Monster Moto recommends that you use a garden hose and a soft sponge to wash your mini bike, as high pressure washers and harsh brushes can damage certain parts of the mini bike. To avoid damaging the mini bike, never aim water directly at the engine or surrounding components. Never wash the mini bike while the engine is running. Always lubricate the drive chain after cleaning and drying the mini bike.

TROUBLESHOOTING

If you are having problems with your mini bike, please reference the troubleshooting steps below. If you have completed all of the troubleshooting steps and your mini bike is still not running properly, contact Monster Moto at 855-833-6483 or info@monstermoto.com or take your mini bike to an Authorized Monster Moto Service Center. Remember, always feel free to contact Monster Moto customer service with any questions. Our goal is to provide you with a seamless mini bike ownership experience!

IF THE ENGINE DOES NOT START	
POTENTIAL PROBLEM	SOLUTION
Engine stop switch in “off” position	Turn the engine stop switch to the “on” position. See step 1 under <i>Starting Your Mini Bike</i> on page 10 for more information.
Fuel valve switch in the “off” position	Turn the fuel valve switch to the “on” position. See step 2 under <i>Starting Your Mini Bike</i> on page 10 for more information.
Improper choke operation	Ensure that the choke lever is in the correct position. See steps steps 3 through 7 under <i>Starting Your Mini Bike</i> on page 10 to ensure you are operating the choke correctly.
Empty fuel tank	Add fuel to the fuel tank. See <i>Adding Fuel</i> on page 12 for refueling instructions.
Flooded engine	Clear the flooded engine. See <i>Clearing A Flooded Engine</i> on page 14 for relevant instructions.
Clogged fuel cap vent	Clean the fuel cap vent. See <i>Cleaning The Fuel Cap Vent</i> on page 14 for relevant instructions.
Contaminated fuel system	See <i>Removing Sediment From The Fuel System</i> on page 13 and <i>Adding Fuel</i> on page 12 for more information.

IF THE MINI BIKE IS NOT PERFORMING WELL

POTENTIAL PROBLEM	SOLUTION
Improper choke operation	Ensure that the choke lever is in the correct position. See steps 3 through 7 under <i>Starting Your Mini Bike</i> on page 10 to ensure you are operating the choke correctly.
Incorrect oil level	Ensure oil is at the proper level. See <i>Checking And Adding Engine Oil</i> on page 15 for more information.
Partial obstruction in fuel cap vent	Clean the fuel cap vent. See <i>Cleaning The Fuel Cap Vent</i> on page 14 for relevant instructions.
Use of poor quality fuel	Drain the tank and refuel the mini bike with a higher octane fuel. See <i>Removing Sediment From The Fuel System</i> on page 13 and <i>Adding Fuel</i> on page 12 for more information.
Contaminated fuel system	Remove sediment from the fuel system and refuel the mini bike. See <i>Removing Sediment From The Fuel System</i> on page 13 and <i>Adding Fuel</i> on page 12 for more information.
Dirty air filter	Clean the air filter. See <i>Cleaning The Air Filter</i> on page 17 for relevant instructions.
Low or flat tire	Refill, repair, or replace the tire. See <i>Tires</i> on page 19 for more information.
Excess drag on the engine	Perform a rear brake adjustment. See <i>Adjusting The Brakes</i> on page 18 for more information.

IF THE MINI BIKE DOES NOT STOP

POTENTIAL PROBLEM	SOLUTION
Unresponsive brakes	Perform a rear brake adjustment. See <i>Adjusting The Brakes</i> on page 18 for more information.

IF THE MINI BIKE HANDLES POORLY

Never ride a mini bike that has handling problems. Poor handling is an indication of a bent rim, a damaged frame, or damaged forks. These problems need to be fixed by an Authorized Monster Moto Service Center. Do not continue to operate the mini bike. Take it to an Authorized Monster Moto Service Center for repair.

WARRANTIES

LIMITED WARRANTY

WHAT IS COVERED

Monster Moto warrants only to the original retail purchaser of this product that this product is free from defects in material and/or workmanship for a period of ninety (90) days from the date of purchase. At Monster Moto's sole discretion, Monster Moto agrees to either repair, provide replacement parts for, or replace without charge, any product or component having a material defect, except as limited below. Monster Moto may require the purchaser to return to Monster Moto, at the purchaser's expense, the part(s) or product component(s) claimed to be defective for Monster Moto's inspection and sole determination of defect. At that time, the returned part(s) or product component(s) become the property of Monster Moto and will not be returned. This product is also covered by an Emissions Control System Warranty which is separate from and in addition to this warranty.

WHAT IS NOT COVERED

This warranty does not cover any conditions caused by misuse, neglect, negligence, accident, or operation in any way contrary to the operating instructions located in the owner's manual. Damage to the product resulting from normal wear and tear, alteration or modification of the product, improper or inadequate maintenance, use of unauthorized replacement parts, or service provided by anyone other than an Authorized Monster Moto Service Center is not covered under this warranty. This warranty does not cover minor surface blemishes, rips, tears, or other cosmetic damages due to normal use, or due to intentional or unintentional damage to the product. This limited warranty will not cover any damage which results from the application of improper cleaners, solvents, or chemicals to the product, from smoke or soot, or from exposure to saltwater, sea breeze, or salt. This limited warranty will not cover any damage resulting from storing the product with exposure to the elements. Without limiting the above, this warranty is void with respect to any product that has sustained damage resulting from impacts, accidents, or uses considered by Monster Moto to be outside of the scope of normal and safe operation, including, but not limited to, performing tricks, stunts, or jumps.

LIMITATIONS OF LIABILITY

This warranty is non-transferable after the product's initial sale. Any unapproved modifications to the product or its performance will void this limited warranty. This warranty does not cover products used for rental or commercial purposes, nor does it cover products used in competition. This limited warranty covers only the cost of replacing and/or repairing parts which have a manufacturer's defect in material or workmanship. This warranty does not cover the cost of transportation, towing, lost time, inconvenience, or any incidental or consequential damages of any type. This limited warranty does not cover costs resulting from improper repairs or misdiagnosis of problems. Except with respect to the emissions control system warranty required

by the Environmental Protection Agency, Monster Moto makes no other warranty of any kind, express or implied. All implied warranties of merchantability and fitness for a particular purpose which exceed the obligations and time limits stated in this warranty are disclaimed and excluded from this warranty. You may have additional or different rights under your state's laws.

OWNER'S RESPONSIBILITIES

As the mini bike owner, you are responsible for ensuring all required maintenance is performed on your product. You are also responsible for maintaining a record of and all receipts for maintenance performed on your product. Your warranty claim may be denied solely due to your failure to ensure the completion of all scheduled maintenance or keep the maintenance records or receipts.

KEEP YOUR RECEIPT

Proof of purchase will be required to substantiate any warranty claim. As the mini bike owner, warranty coverage may be denied if your mini bike or one of its parts has failed due to abuse, neglect, improper maintenance, or unapproved modifications.

EMISSIONS CONTROL WARRANTY

WHAT IS COVERED

Monster Moto warrants to the initial retail purchaser and each subsequent purchaser of this vehicle that the vehicle's new engine, including all parts of its emissions control system, meets two conditions:

1. It is designed, built, and equipped so it conforms at the time of sale to the initial retail purchaser with the requirements of the Environmental Protection Agency (EPA).
2. It is free from defects in materials and workmanship that may keep it from meeting the requirements of the EPA.

This emissions control warranty is valid for 30 months from the date the vehicle is sold to the initial retail purchaser.

The emissions control system warranty covers all components whose failure would increase an engine's emissions of any regulated pollutant, including components listed in 40 CFR part 1068, Appendix I (published by the EPA), and components from any other system designed to control emissions. The emissions control warranty does not cover components whose failure would not increase an engine's emissions .

WHAT IS NOT COVERED

Warranty claims will be denied if the vehicle operator caused the problem through improper maintenance or use, as described in 40 CFR 1068.115. (published by the EPA)

SPECIFICATIONS

RECOMMENDATIONS	
Recommended Age	16 +
Recommended Fuel Type	Unleaded 87 Octane Gasoline
Recommended Engine Oil Type	SAE 10W-30
SPECIFICATIONS	
Engine Displacement	79.8 cc
Strokes per Cycle	Four Strokes per Cycle
Cylinder Head Configuration	Overhead Valve (OHV)
Transmission	Automatic Centrifugal Force Clutch
Maximum Speed	26 mph
Starter Type	Pull Start
Fuel Tank Capacity	.32 gal
Oil Tank Capacity	12 oz
Spark Plug Gap	0.6 - 0.7 mm
Brake Type	Cable Rear Disc
Tire Pressure	15 psi
Number of Cylinders	1
Valves per Cylinder	2
Rated Power	1.1 kW @ 3,600 rpm
Rated Torque	3.1 Nm @ 3,240 rpm
Horsepower	2.5 hp
Bore and Stroke	52.0 mm x 37.4 mm
Number of Carburetors	1
Number of Barrels per Carburetor	1
Basic Ignition Timing (10°, Electronically Controlled)	28 BTDC
Gear Ratio	6.81:1
Compression Ratio	8.5:1
Valve Clearance	0.05 - 0.1 mm Int and Ex
Idle Speed	1,600 +/- 150 rpm
Final Drive	Chain
Number of Teeth in Front Sprocket	11
Number of Teeth in Rear Sprocket	75
DIMENSIONS	
Assembled L x W x H	50.0" x 26.0" x 33.0"
Assembled Weight	78 lb
Carton L x W x H	50.3" x 15.0" x 25.5"
Carton Weight	99 lb
Wheelbase	36.5"
Ground Clearance	4.5"
Seat Height	23.0"
Front and Rear Tire Size	14.0X5.7R6.0 Pneumatic
Front and Rear Rim Size	7.0"
Turn Radius	122.0"



MINI BIKE MM-B80



PRODUCT REGISTRATION

Monster Moto

1001 South Jupiter Road | Garland, TX 75042 | 855-833-6483
info@monstermoto.com | www.monstermoto.com



Please help us serve you better by registering your new mini bike. You may register your product by calling us at 855-833-6483, by emailing us at info@monstermoto.com, or by mailing the registration form below to us at 1001 South Jupiter Road, Garland, TX 75042.

PERSONAL INFORMATION

Name _____ Age _____

Address _____

City _____ State _____ Zip _____

Email _____

Home Phone (____) _____ Cell Phone (____) _____

Gender _____ Occupation _____

How did you hear about the product? _____

Have you owned a similar product before? _____

PRODUCT INFORMATION

Purchase Date _____ Purchased From _____

Vehicle Identification Number (VIN)

--	--	--	--	--	--	--	--	--	--	--	--	--	--	--	--	--	--	--	--

(See page 9 for help locating the VIN.)

**IF YOU HAVE PROBLEMS,
DO NOT RETURN TO STORE!**

**CONTACT MONSTER MOTO AT
855-833-6483
OR
INFO@MONSTERMOTO.COM!**

**Monster Moto will handle all
service, warranty, and return
arrangements.**



Monster Moto

1001 South Jupiter Road | Garland, TX 75042 | 855-833-6483
info@monstermoto.com | www.monstermoto.com

