

The bottom right of the cover representing: "read this user manual carefully before you use the appliance and keep it for future reference."

## Preface

Respected users,

Thank you for using XXX electric baking oven (air fryer). This specification is only applicable to YJ993A products. All the contents of the manual are only for reference for the users using and maintenance, not completely matters, welcome to consult the customer service department of the company.

May XXX electric baking oven (air fryer) will bring your life with warm, convenient and healthy.

## Content

Chapter I Safety Instructions.....	1
Chapter II Parts and its function.....	x
Chapter III Operation panel and its function description.....	x
Chapter IV Operating instructions.....	x
Chapter V Cleaning & Care .....	x
Chapter VI Troubleshooting Guide.....	x

## Chapter I Safety Instructions



Warning: please be vigilant about risk, serious injury, and major loss of property that may lead to personnel.

During work, the surface temperature of the front part, the left and right side and the upper part of the product will increase. The area / surface with the sign  will become hot during the work. Please be careful to be burned.



Note: please pay attention to the risks that may lead to injury to the person or damage to the articles.

1. This product is for household use only. Do not use it for other purposes.
2. This appliance is not intended for use by persons (including children) with reduced physical, sensory or mental capabilities, or lack of experience<sup>[SEP]</sup>and knowledge, unless they have been given supervision or instruction concerning use of the appliance by a person responsible for their safety. <sup>[SEP]</sup>Children should be supervised to ensure that they do not play with <sup>[SEP]</sup>the appliance. <sup>[SEP]</sup>
3. After the package opened, please put the plastic bag into the trash to avoid children

play and cause the danger of suffocation.

4. The packaging material must be taken off while using; otherwise during the working the product will lead to fire, burn and so on.

5. The input voltage of the product is 120V/60Hz, before connecting the product to the power supply, please check whether it is in line with the local power supply voltage, higher or lower voltage may damage the components or affect the performance of the product. In order to avoid loss, it is suggested that the regulator should be used.

6. This product is type I electric appliance, before using please ensure that grounding wire is in good condition, so as to avoid leakage accident.

7. It is necessary to use 10A or above grounding socket alone. The plugs must be inserted into the socket thoroughly, so as to prevent the elements from overheating and burn out, causing short circuit or fire hazards.

8. Please do not run this appliance in the mode of external timer or independent remote control system so as to prevent short circuit, self-ignition and other dangers.

9. The appliance is strictly prohibited for other purpose of using other than food baking.

**10. It is strictly forbidden to plug or pull the power plug with wet hand in order to avoid electric shock.**

11. Please operate the appliance on the even and stable surface. In case of fire please do not operate this product on flammable materials such as carpet, towel, plastic, paper and so on.

12. Please do not use this product on unstable, humid, high temperature, smooth and heat-labile countertops, so as to avoid injuries, accidents and property losses caused by electric shock, fire and slipping.

13. Please do not use this product with environment of gas and electric leakage; otherwise which will cause fire and electric shock.

14. Please do not use this product under or near the flammable materials such as curtains, and closets to prevent fire.

15. Please do not let the product working in the case of no one take care of it, in order to prevent food burnt causing fire and other dangers.

16. During appliance is used, there should be enough space for its working and keep at least 10cm distance from the surrounding objects in order to prevent the oil and smoke pollution of furniture, and even the danger of fire.

17. Please ensure that the power line does not contact with sharp edges, edges, other sharp objects or surface of high heat, in order to prevent electric leakage and cause electric shock or fire.

18. During working, please use the [handle of the frying basket](#). It is forbidden to touch the high temperature surface and interior of the product to avoid scalding.

19. This product shall not be air burned for a long time (without any food), in case of self-ignition causing damage accidents and property losses. It is suggested that it should not be used for more than [3 hours](#).

20. During operation, please don't put bagged, canned or bottled items, cotton cloth or flammable materials on the products' surface or cover products, to avoid fires and explosions.

21. It is forbidden to put any flammable materials such as paper, plastic and other kinds

of materials into the electric baking oven to avoid the danger of fire.

22. The explosive items such as glassware, closed containers and other items are not allowed to place in an electric baking oven to be heated so as to avoid the danger of explosion.

23. During the process to ensure that the food does not come up against the heating pipe shield; please do not bake large food, otherwise it will easily lead to smoke, fire.

24. It is strictly forbidden to touch the stirring blade and the high temperature parts in the pan during working or before cooling, so as to avoid scalding.

25. If acidic ingredients that PH value is less than 5 were baked (such as vinegar, lemon juice and other sauces), please be sure to use foil packs.

26. The product will generate high temperature and steam during the operation, do not touch or close your face to it. Especially when opening the upper cover you should be very careful to prevent the upper cover opening and bruising, and at the same time there may be hot steam coming out of the electric baking oven to prevent scalding.

27. Unplug the plug, must grasp and pull the plug, do not yank or distortion of power line, to avoid power line damage resulting in leakage risk.

28. Please use high temperature heat insulation objects to take high temperature items out to prevent scalding.

29. After each use, the frying pan, frying basket and stirring blade need to be cleaned, to prevent residual slag powder and oil when baking in the next time will cause smoke or fire.

30. After the use of the products, the surface of the heating element still has residual heat. In order to prevent scalding, please clean it after cooling.

31. When there is no one to use, clean or move the product, if the product fails, please remove the power plug to prevent damage caused by electric leakage or accidental start.

**32. If the power cord is damaged, in order to avoid danger, the manufacturer, its maintenance department or the professional staff of the similar department must replace it.**

33. Do not put this product into water or other liquid to wash or immerse, do not spray water on it to avoid components damage or leakage.

34. If the product has broken down or damaged, please stop using it and send it to the service shop of our company, do not repair it by yourself to avoid dangerous.

35. When discarding this product, please cut off the power line and turn it back to the qualified authorities to discard.

#### **Handy hints:**

- ◆ Please take the [air fryer](#), [frying basket](#) and [stirring blade](#) out using cleaning agent to clean prior to the first time using, after cleaning then put into [electrical baking oven](#) and set the time for 10 minutes to preheat so as to eliminate remaining odor in the process of packaging or transport.
- ◆ It may emit slight smoke or odor when using for the first time, which is normal with appliance.

- ◆ The use of original accessories that are recommended.
- ◆ The light in the machine is generated by heating tube, when the machine reaches the set temperature, the heating tube stop heating, light will temporarily disappear, when the temperature is lower than the set temperature, the heating tube back to work, light shows again, which is normal.
- ◆ Do not use heat-liable containers such as plastic or paper to carry food into the electric baking oven;
- ◆ Do not use glass or ceramic plate or cover;
- ◆ The air fryer is not a water components, when the water level of the air fryer is too high that causing water leakage, which is normal, it is recommended to put the air fryer into water pool for cleaning, don't put water into the appliance;
- ◆ The machine is in a period of time after the end of the work and working state, the outer surface and the air outlet temperature may be very high, do not touch, and move, so as to avoid danger.

## Chapter II Parts and its function

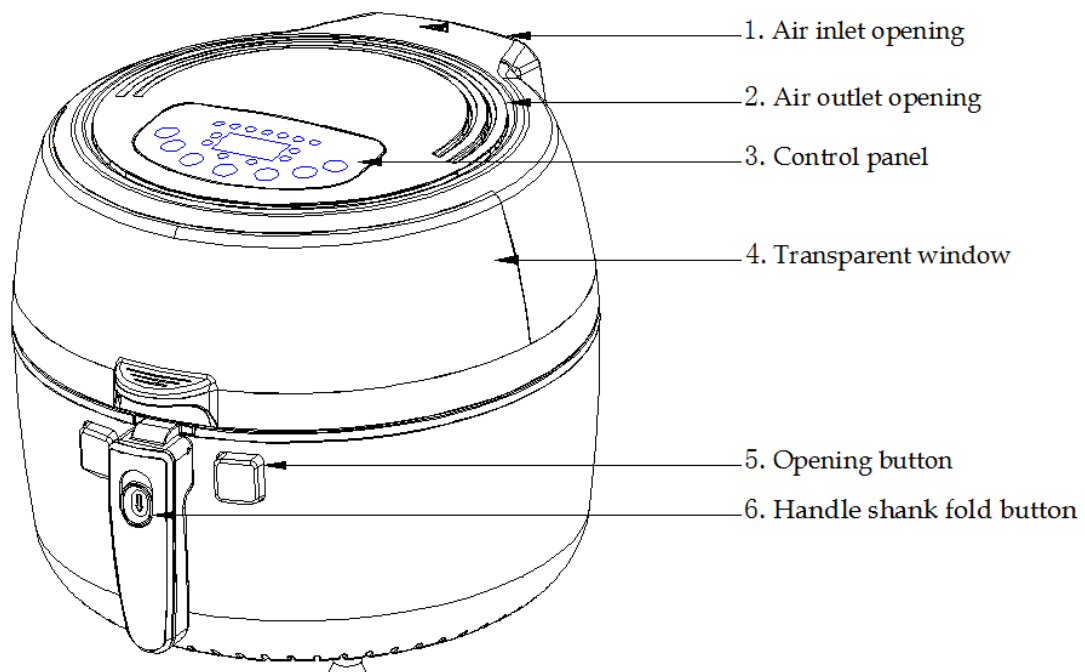

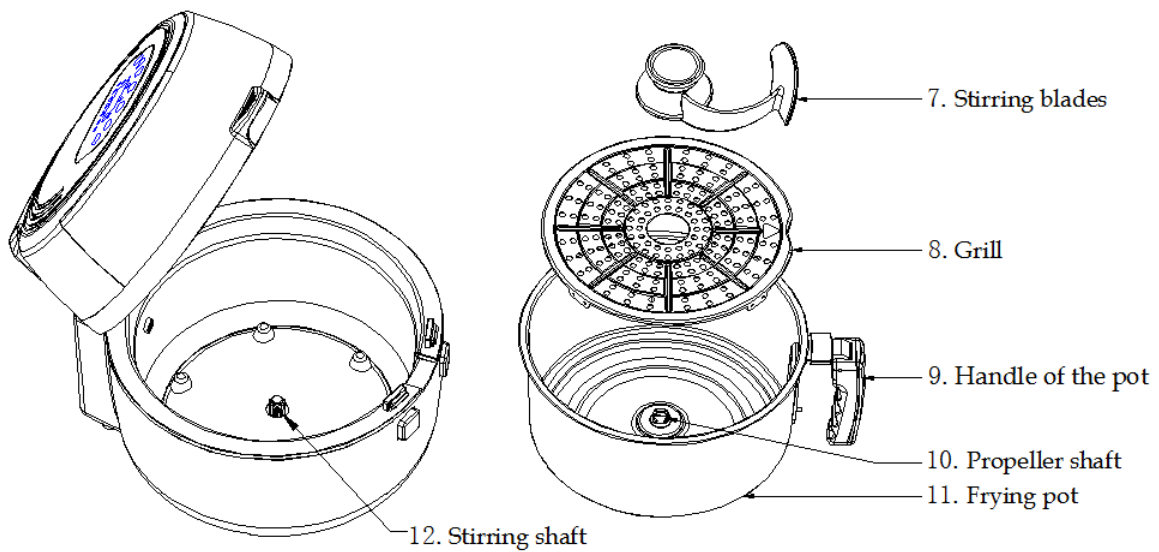

S.N.	Name of parts	Function
1	Air inlet opening	Sucking cold blast air for cooling down the appliance
2	Air outlet opening	Air outlet opening for eliminating hot air
3	Control panel	Setting for temperature, time, start/cancel
4	Transparent window	Using to observe the food baking status in it
5	Opening button	Press this two buttons with hands at the same time then the entire upper part will open to let you fetch and put food
6	Handle shank fold button	When hand hold the knobs, slide to the direction of the palm of the hand meanwhile turn the knobs downward then can realize the fold of the knobs.
7	Stirring blades	Using to stir the foods so as to ensure it is heated evenly.
8	Grill	For carrying foods
9	Handle of the pot	Folding handle can be used to operate pot.
10	Propeller shaft	Using to delivery power of stirring shaft to stirring blade
11	Frying pot	Using to place foods and other accessories, when installation and place please use hot temperature mitts, so as to avoid danger of scalding.
12	Stirring shaft	Using to provide power of stirring.

### Chapter III Operation panel and its function description



Functional keys corresponding menu options

Tem. "+" , Tem. "-"

Time "+" , Time "-"

Function selection, start/cancel, stirring

WIFI indicator light, stirring indicator light, subscribe indicator light, time indicator light, temperature indicator light

**Hint: The "start" and "cancel" functions of the electric baking oven are set on the same**

**icon** .

1. Function menu: the function menu key has the default mode and the independent mode.

The corresponding diet temperature and time in the default mode are all set, and the ingredients are prepared according to the amount and method of the diet. Finally press

the "start / cancel"  icon on the panel;

2. Adjusting temperature

After cooking mode selected, determine the temperature required for cooking. Please use the temperature adjustment button to adjust to the required temperature. There are two icons of "+" and "-" on the operation panel, each one of them is pressed, then the temperature setting value increases or decreases by 5 centigrade. When one of the icons is pressed, the temperature will increase or decrease rapidly at 5 centigrade. (Temperature adjustment range: 80-200 centigrade, recyclable)

Note 1: if the product starts to run and is heated, it can also adjust the time and temperature.

### 3. Adjusting time:

Determine the time required for cooking food. Please use the time adjustment button to adjust to the time required. There are two icons of "+" and "-" for time adjustment on the operation panel. When each icon is pressed, the time setting value increases or decreases by 1 minute. When one icon is pressed, the time increases rapidly or decreases in 1 minute. (Time adjustment range: 01-60min, recyclable)

Note 1: if the product starts to run and is heated, it can also adjust the time and temperature.

### 4. Start/cancel

After determining the temperature and time required for the cooking food, please press the "start/cancel"  icon on the operating panel. The display screen every 5S will display the temperature and time alternately (from time to start)

If you need to turn off the machine in halfway, you can turn it off manually. To do this, press the "start /cancel" button on the operation panel. After the work is finished, if you need to continue to work, please operate the buttons and adjust it according to the above mentioned steps. )

### 5. Stirring function

When you need to use the stirring function, please assemble the stirring blade, close the upper cover to adjust the corresponding temperature and time, after press the "start /cancel"  icon, and then press "stirring" button, then the corresponding stirring indicator light will shine for long time. When the cooking is finished, the stirring blade will be taken out with the frying basket. Due to high temperature inside, precaution of scalding during operation

### 6. Reservation function

Press the "function" button to select the mode, after set the baking time and temperature, press "function" button, to start reservation mode, the reservation indicator lights is on, press the time "+" and "-" button can set reservation time, and then press "start/cancel" button, the machine will start countdown time. After time ends cooking is finished.

### 7. Preheating function

If you want to preheat, please set the cooking time and temperature first, then press the "stirring" button, At this time, the preheating indicator lamp will light up. After press the "start/cancel" button the machine will work for 5 minutes and keep preheating state. After the preheating is completed, put in foods, close the upper cover of the machine, press the "start /cancel" button again, and the machine enters the working state.

### Note:

1. When the machine ends, you will hear 5 times of "tick" hint, which indicating that the appliance reaches the setting time, and the interface will display "00 min". The fan will

stop working after 45S. After cooking complete take the fryer out from the product, and then place it on the heat-resistant surface (Note: if not exit to the main interface, then every 2 minutes will buzzer once for remind)

2.when opening machine, the main working parts of the machine such as stirring, fan and heating tube will be cut off. The control panel will still keep working state and will continue to work after closing the cover.

## Chapter IV Operating instructions

### ★Before first time use

1. Remove all the packing materials.
2. Take out the frying pan and frying basket remove packing bags.
- 3.Clean the frying pan and frying basket with warm water, wipe the inside and outside of the electric baking oven with a wet cloth immersed in detergent, when it is completely dry then use it.
4. Place the electric baking oven on an even and stable surface. Please use a single power supply line.
- 5.There should be enough space around the electric baking oven to ensure that its surface to other items keep at least 10cm distance, the air outlet cannot place any items.

### Note:

For the first time, it is necessary to preheat the electric baking oven for 5 minutes in order to remove the residual oil and smoke.

There may be bad smell when first time use, this is normal, and it is not the electric baking oven failure.

### ★Operating instructions step-by-step:

1.Place the frying pan into the machine, and place the frying basket into the frying pan, if need for stirring, to equip the stirring blade into to the stirring shaft.

2.Put food into frying basket and make sure that the height of the food does not exceed the height of the frying basket.

3.Close the machine cover; plug the power supply, the operation panel has sound and indicator light.

4.Press "function" button, select the independent mode or the default menu mode

5.The time and temperature can be adjusted in the independent mode. The default menu has the set time and temperature.

6. After the setting is completed, press the "start /cancel" button.



7. According to your need to press "stirring" button, to start the stirring function, at this time the stirring indicator light will keep long bright.

8. If you need to finish the baking ahead of time, press "start / cancel" button

9. After baking complete, the machine has a buzzer sound, press the open button and take out the food. For the oiled food, it is advised to take the frying pan frying basket and stirring blade together out, to prevent the oil drop to the desktop. In the process of operation, please pay attention to the scalding.



#### Tips:

※For better baking, it is recommended preheating 5 minutes before using.

※Some of the foods can be wrapped by foil for better baking;

※Time can be adjusted according to personal tastes, to observe from the window to avoid food scorched;

※While continuous baking the previous uses pan should be clean up, so as to avoid next time baking producing burning smoke or affect the appearance of food;

### Chapter V Cleaning & Care

1. Before cleaning the electric baking oven, please cut off the power and unplug, after it cools completely.
2. If there is oil at the electric baking oven, please wipe it with a soft damp cloth immersed with mild detergent.
3. Frying pan, frying basket, stirring blade and other accessories could be took out and then cleaned in water.
4. Do not immerse the whole unit in water or other liquid to clean, in order to avoid the danger of electric shock or functional failure.
5. After cleaning, wait until the product is dried and put it in a cool and dry place.

### Chapter VI Troubleshooting Guide

Problem	Possible	Resolution(s)
---------	----------	---------------

	<b>Cause(s)</b>	
Air fryer does not work	The appliance is not plugged in	Insert the plug into an appropriate grounded power socket
	Did not start	Start operation control panel
The ingredients fried in the fryer are not completely cooked	Too many ingredients were used	Place ingredients by batch into the fry basket
	The cooking temperature is too low	Set temperature control button at required temperature
	The cooking time is too short	To fry for a longer time
The food is fried unevenly	While cooking without stirring	Need ideal stirring
Fried snacks are not crisp	Used not the traditional ingredients	Use snacks designed to be baked in a traditional oven, or lightly brush some olive onto the snacks
Cannot slide the frying basket into the appliance properly	Frying basket handle is not placed correctly	Install frying basket properly, adjust the height of foods, place ingredients according to required capacity
	There are ingredients in air fryer	
	There are too much food in frying basket cannot close	
White smoke is coming out of the product	You are frying greasy foods	It is normal when you are preparing greasy ingredients in air fryer, large amounts of oil can smoke
	The pan contains greasy residue from previous uses	Make sure you clean the frying pan properly after each use
Stirring blade not working	Stirring blade was not properly constructed with synchronous motor	Press button, reconstruct it
	Stirring function not started	Check the status of stirring function
	The baked ingredients is too large, stirring blade blocked	Adjust the size of ingredients, start again
Display screen shows "E01"	Temperature sensor open ended	Contact customer service center or come to local special shop for maintenance

Display screen shows "E02"	Temperature sensor short circuit	Contact customer service center or come to local special shop for maintenance
When finish or cancel, fan not stop timely	Fan with 45 seconds time lapse shut down to protect machine	It is normal, after 45 seconds fan will be shut down automatically

- If the problem cannot be solved, do not knock down the machine. Please send it to the local after-sales service department for maintenance. For details, please refer to the "after-sales service" content or dial the Sunshine Service Hotline: 400-6186-999 for consultation.
- The above-mentioned if there is type or parts change that does not match with the physical appliance, according to the real object please, subject to change without notice, your attention will be appreciated.