

USL

SK19276C2
PORTLAND KICHEN CART
ASSEMBLY INSTRUCTIONS

Made In China

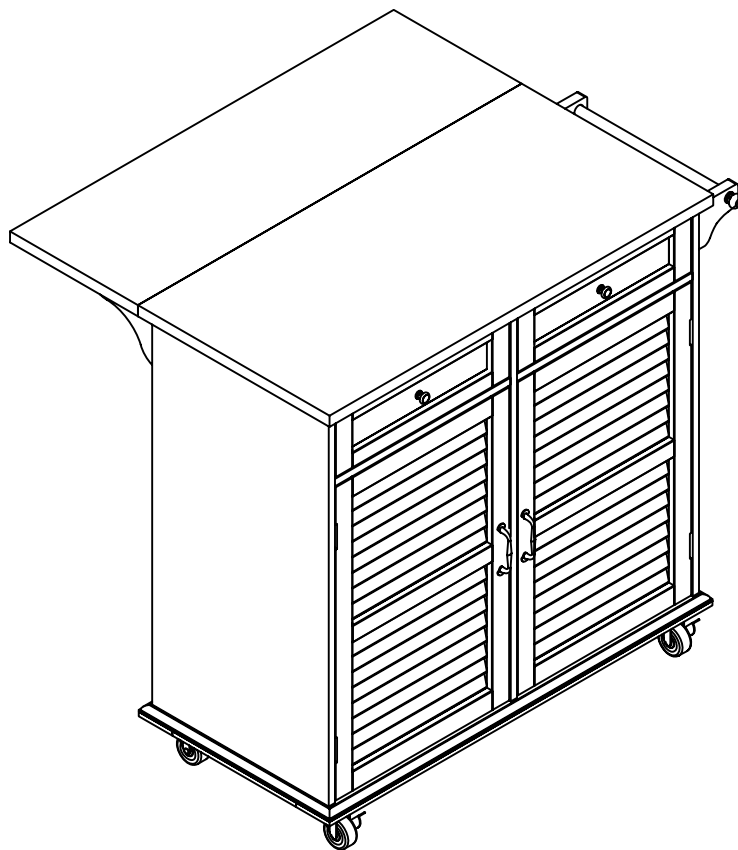

Thank you for purchasing this quality product. Be sure to check all packing material carefully for small parts, which may have come loose inside the carton during shipment. Count all parts and material hardware, then compare with parts list to be sure all parts are present. If any parts are missing or damaged, please contact our Customer Service Department for efficient and speedy service. Please indicate the model number and code letter of part(s) needed.

IMPORTANT NOTE: Follow instructions listed below in proper sequence as numbered to assure fast, easy and correct assembly.

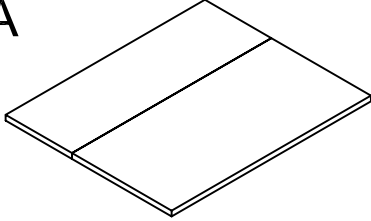
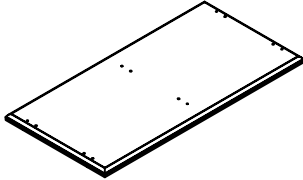
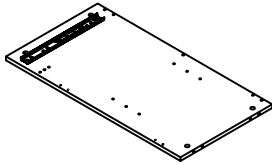
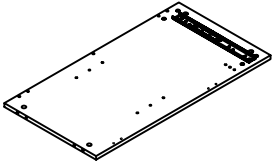
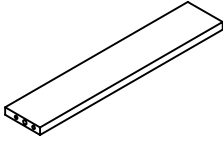
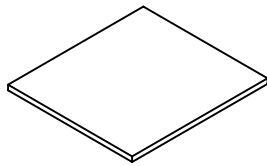
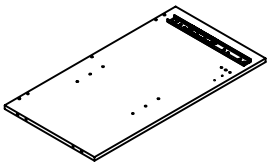
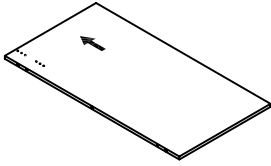
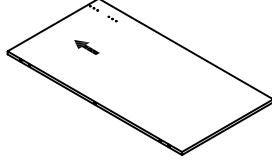
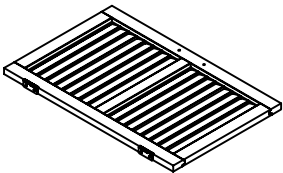
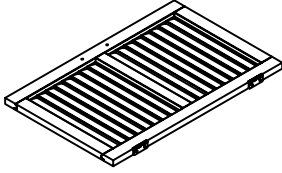
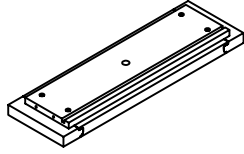
PARTS LIST		
A 	B 	C 
TOP PANEL -1PC	BOTTOM PANEL -1PC	LEFT SIDE PANEL -1PC
D 	E 	F 
RIGHT SIDE PANEL -1PC	CROSS BRACE -2PCS	ADJUSTABLE SHELF -2PCS
G 	H 	I 
PARTITION -1PC	RIGHT BACK PANEL -1PC	LEFT BACK PANEL -1PC
J 	K 	L 
LEFT DOOR -1PC	RIGHT DOOR -1PC	DRAWER FRONT PANEL -2PCS

M

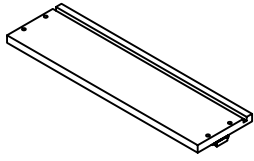

DRAWER
LEFT SIDE PANEL -2PCS

N

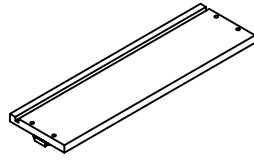

DRAWER
RIGHT SIDE PANEL -2PCS

O

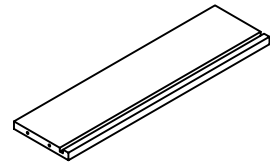

DRAWER BACK PANEL -2PCS

P

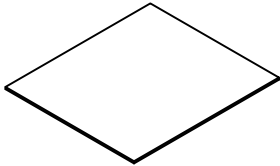

DRAWER
BOTTOM PANEL -2PCS

Q

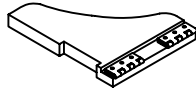

LEFT SIDE SUPPORT -1PC

R

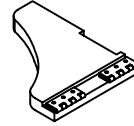

RIGHT SIDE SUPPORT -1PC

S



TOWEL RACK LEFT SIDE -1PC

T



TOWEL
RACK RIGHT SIDE -1PC

U

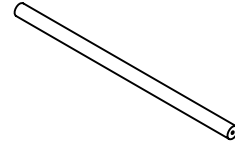

TOWEL RACK BAR -1PC

a



WOOD DOWEL-28PCS

b

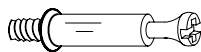





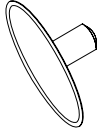
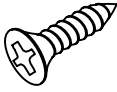

CAM
LOCK BOLT-28PCS

c

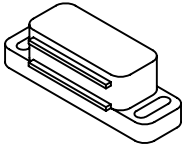
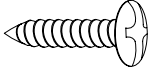
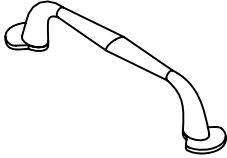

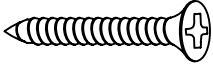
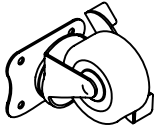
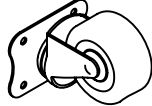
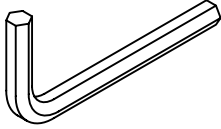
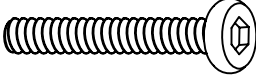
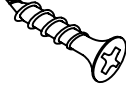
CAM LOCK-28PCS

<p>d</p>  <p>LONG PLASTIC COVER -6PCS</p>	<p>e</p>  <p>SHORT PLASTIC COVER -8PCS</p>	<p>f</p>  <p>1/2"L FLAT HEAD SCREW-20PCS</p>
<p>g</p>  <p>KNOB-2PCS</p>	<p>h</p>  <p>MAGNET-2PCS</p>	<p>i</p>  <p>5/8"L ROUND HEAD SCREW-4PCS</p>
<p>j</p>  <p>HANDLE-2PCS</p>	<p>k</p>  <p>HANDLE BOLT-6PCS</p>	<p>l</p>  <p>SHELF PIN-8PCS</p>
<p>m</p>  <p>1" L FLAT HEAD SCREW-16PCS</p>	<p>n</p>  <p>UNIVERSAL WHEEL WITH BRAKE -2PCS</p>	<p>o</p>  <p>UNIVERSAL WHEEL -2PCS</p>
<p>p</p>  <p>WRENCH-1PC</p>	<p>q</p>  <p>BOLT-4PCS</p>	<p>r</p>  <p>5/8"L FLAT HEAD SCREW-16PCS</p>
<p>s</p>  <p>KNOB-2PCS</p>		

NOTE:THE SURFACE WITH THE STICKER IS THE BACK SIDE

HOW TO REMOVE DRAWERS

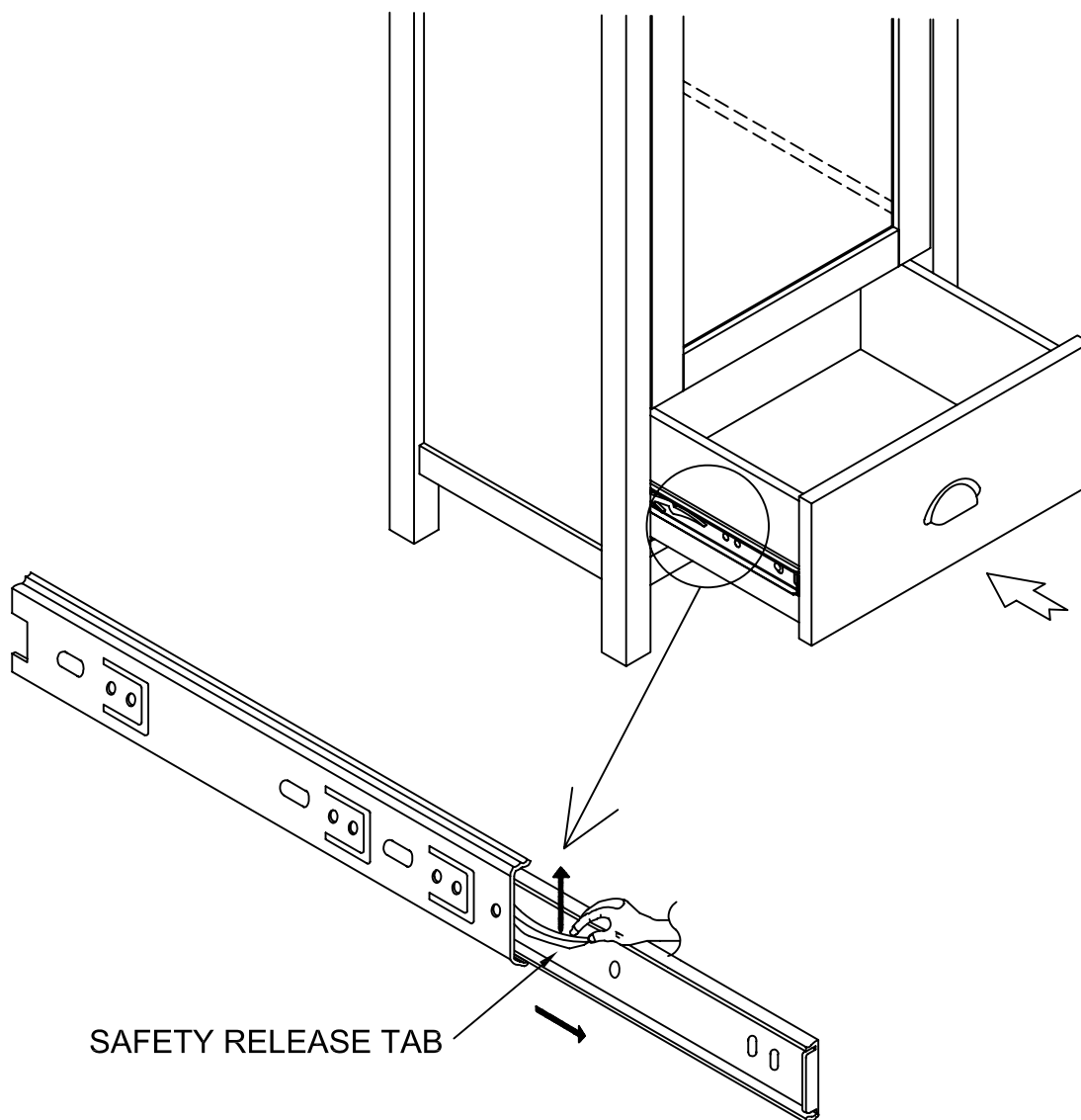

WHEN REMOVING DRAWERS, WE SUGGEST SEPARATING THE INNER GLIDES FROM THE OUTER-GLIDES, SIMPLY PULL THE LEFT/RIGHT INNER GLIDES FROM THE OUTER GLIDES EXPOSING A SMALL BLACK SAFETY RELEASE TAB, BY PUSHING THE SAFETY RELEASE TAB. YOU WILL BE ABLE TO SEPARATE THE GLIDES.

NOTE: • UPON OPENING, THOROUGHLY CLEAN ALL WOOD SURFACES TO REMOVE DUST AND DIRT THAT MAY HAVE SETTLED ONTO THE FINISH DURING SHIPMENT. IN ORDER TO PREVENT DAMAGE DURING ASSEMBLY. PLEASE ASSEMBLE THIS ITEM WITH AT LEAST TWO PEOPLE.

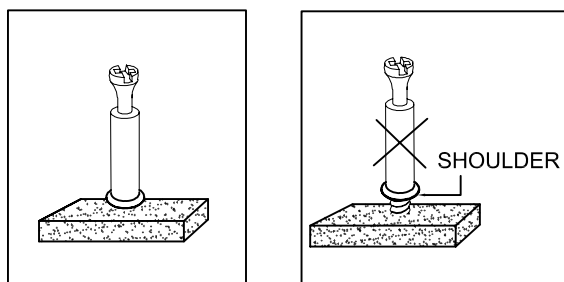

NOTE: TURN THE CAM-BOLT SCREWS UNTIL THEY ARE TIGHT, THE SHOULDER SHOULD BE AGAINST THE SURFACE OF THE PART.

HOW TO USE THE CAM-TOOL

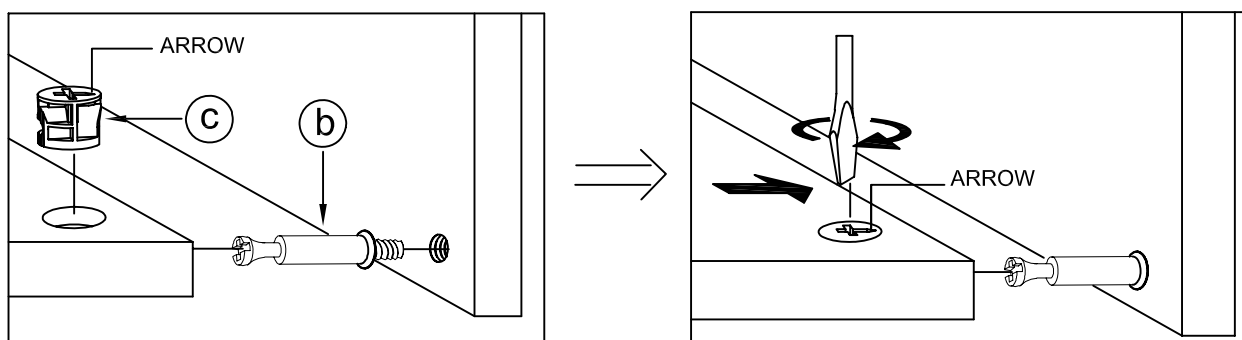

NOTE: • THE ARROWS ON THE HIDDEN CAM-LOCKS SHOULD POINT TO THE CAM-BOLTS.

FIG 1

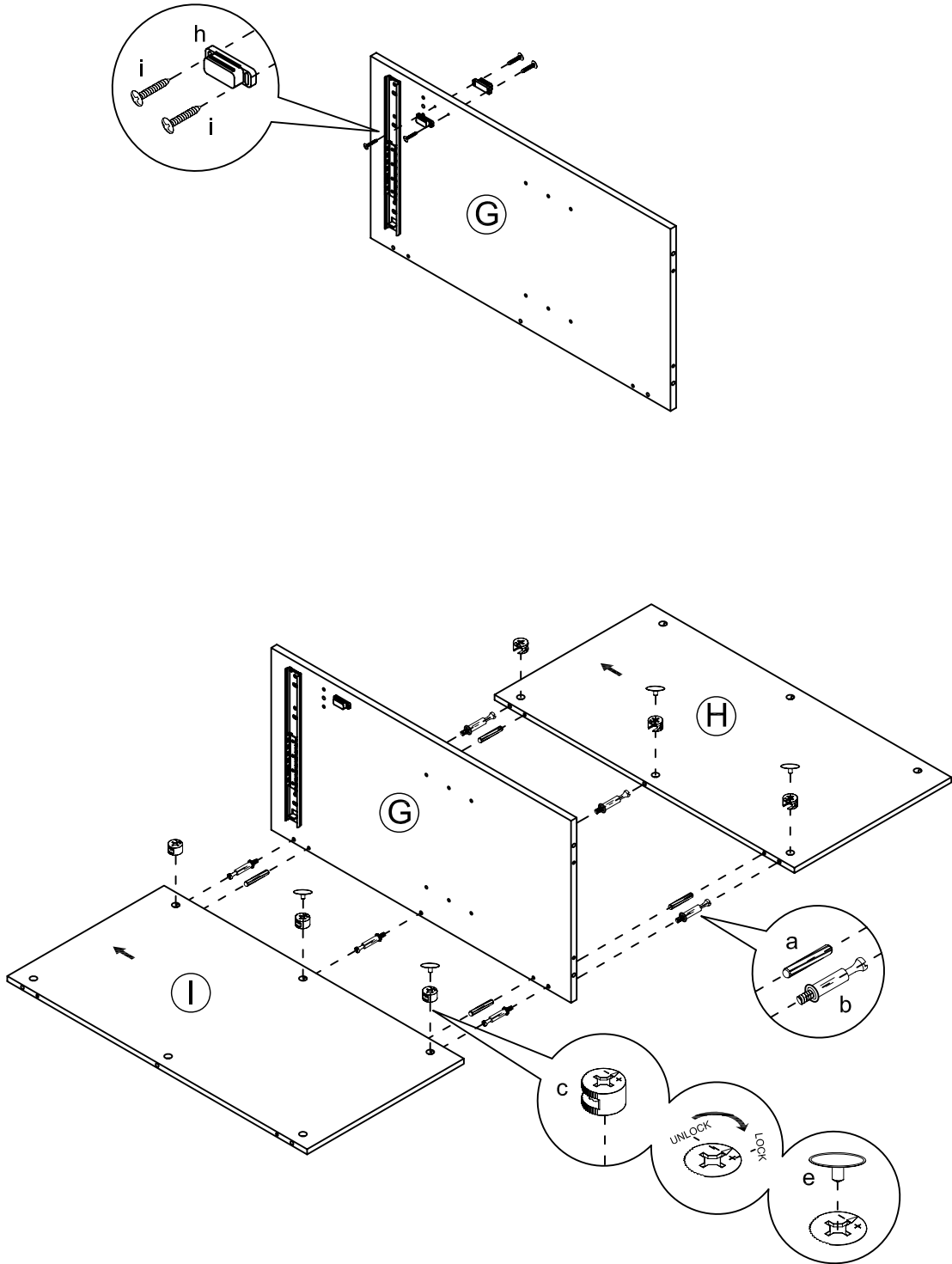

FIG 2

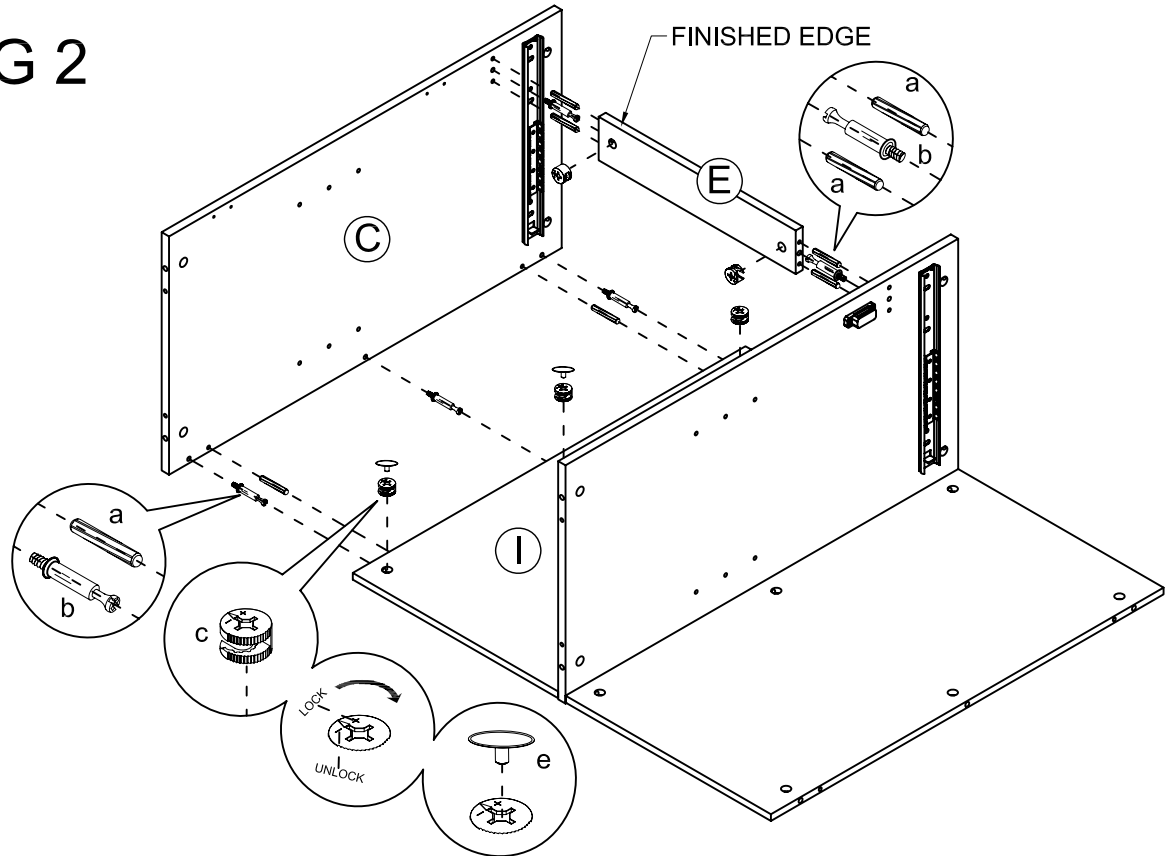

FIG 3

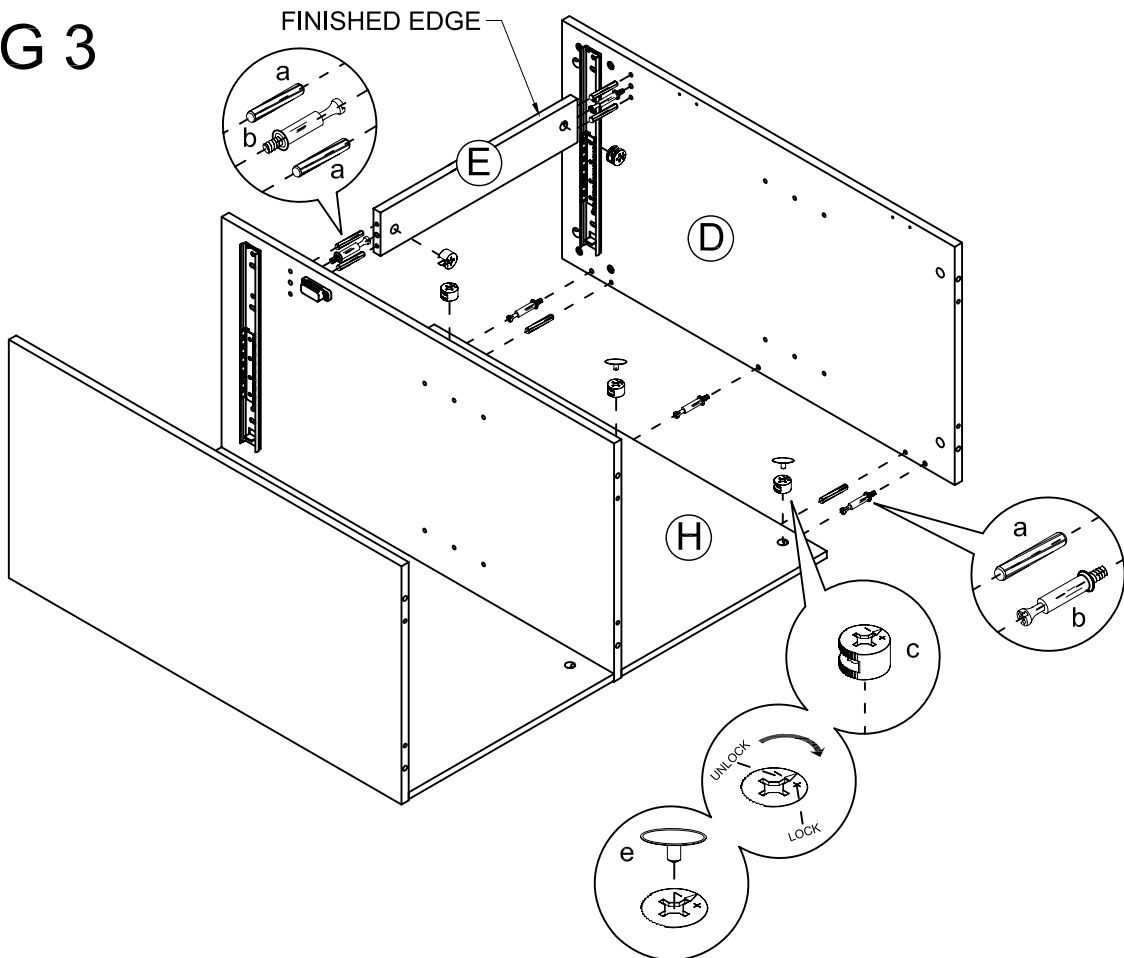

FIG 4

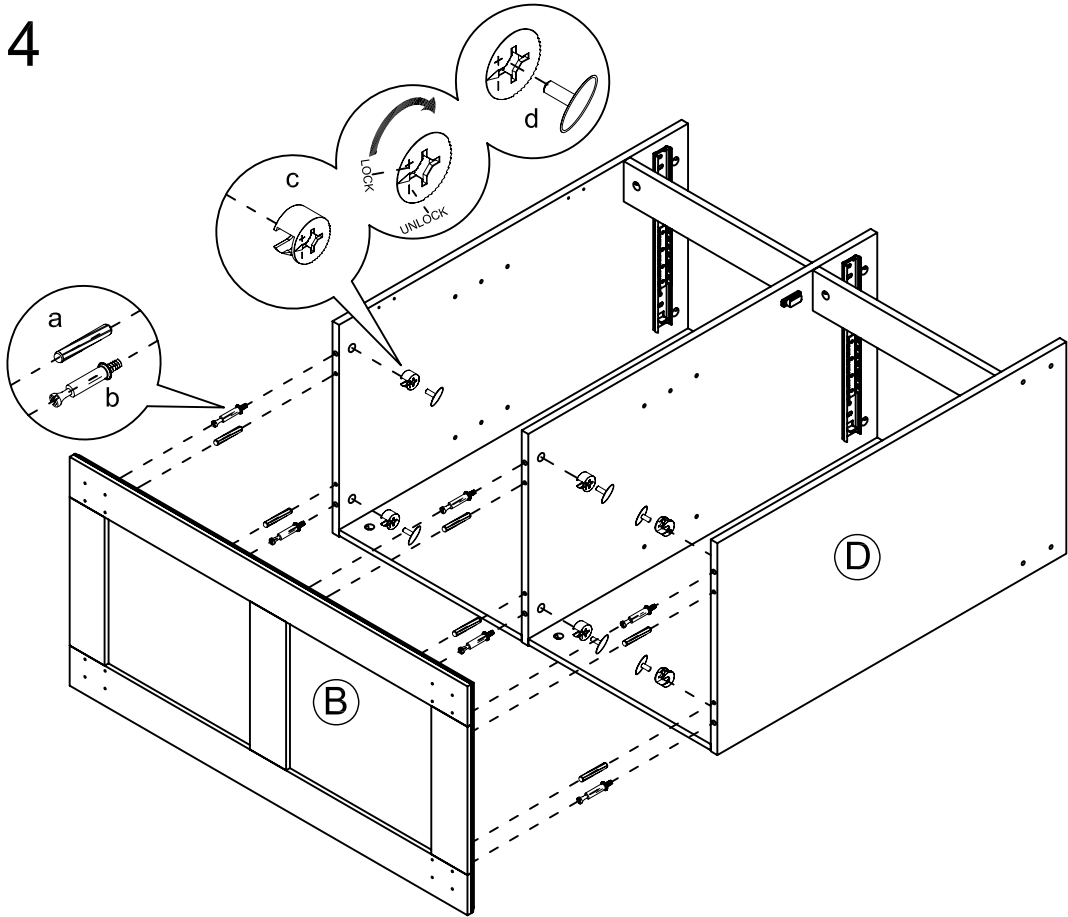

FIG 5

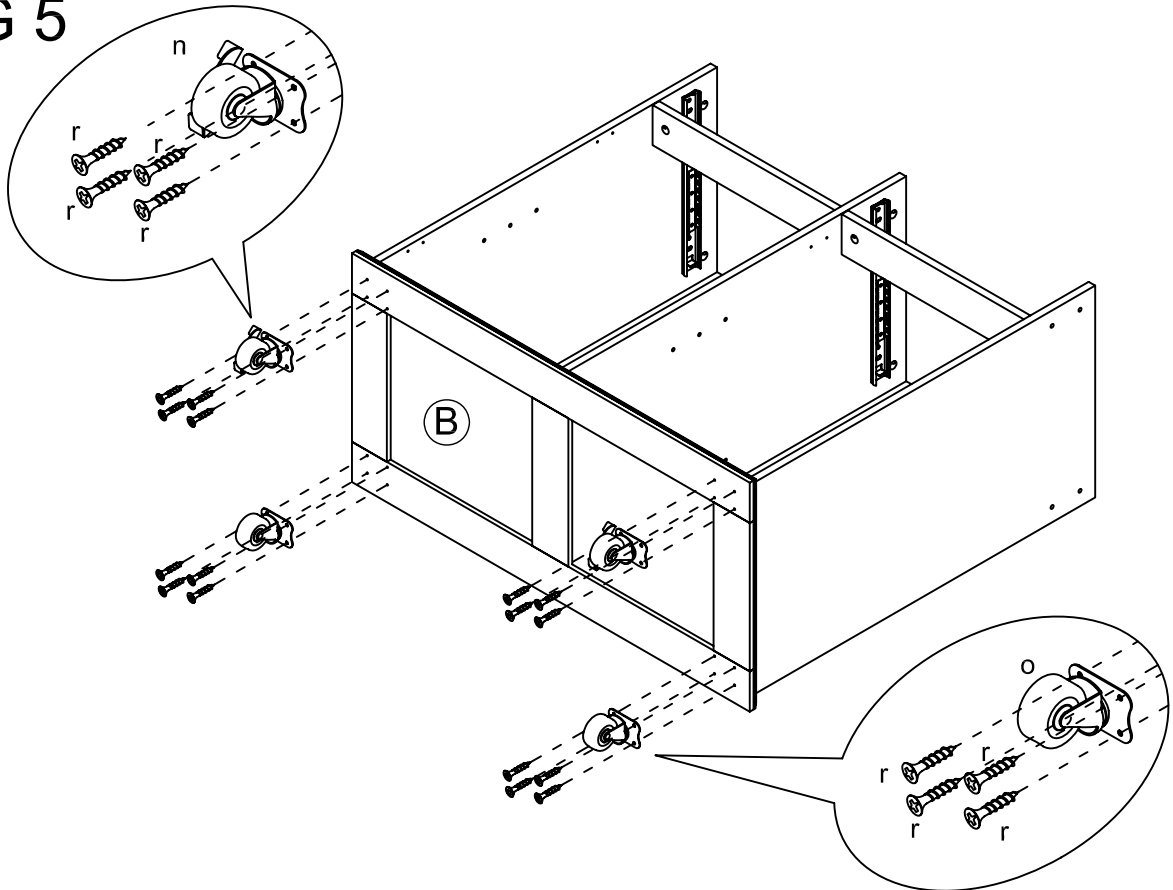

FIG 6

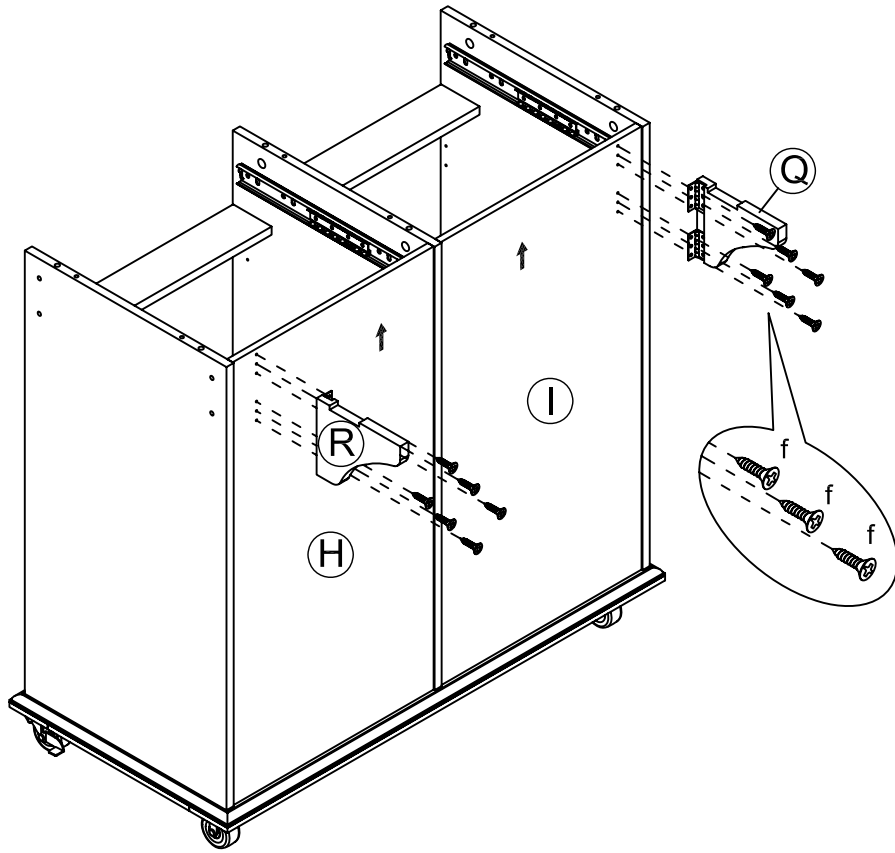

FIG 7

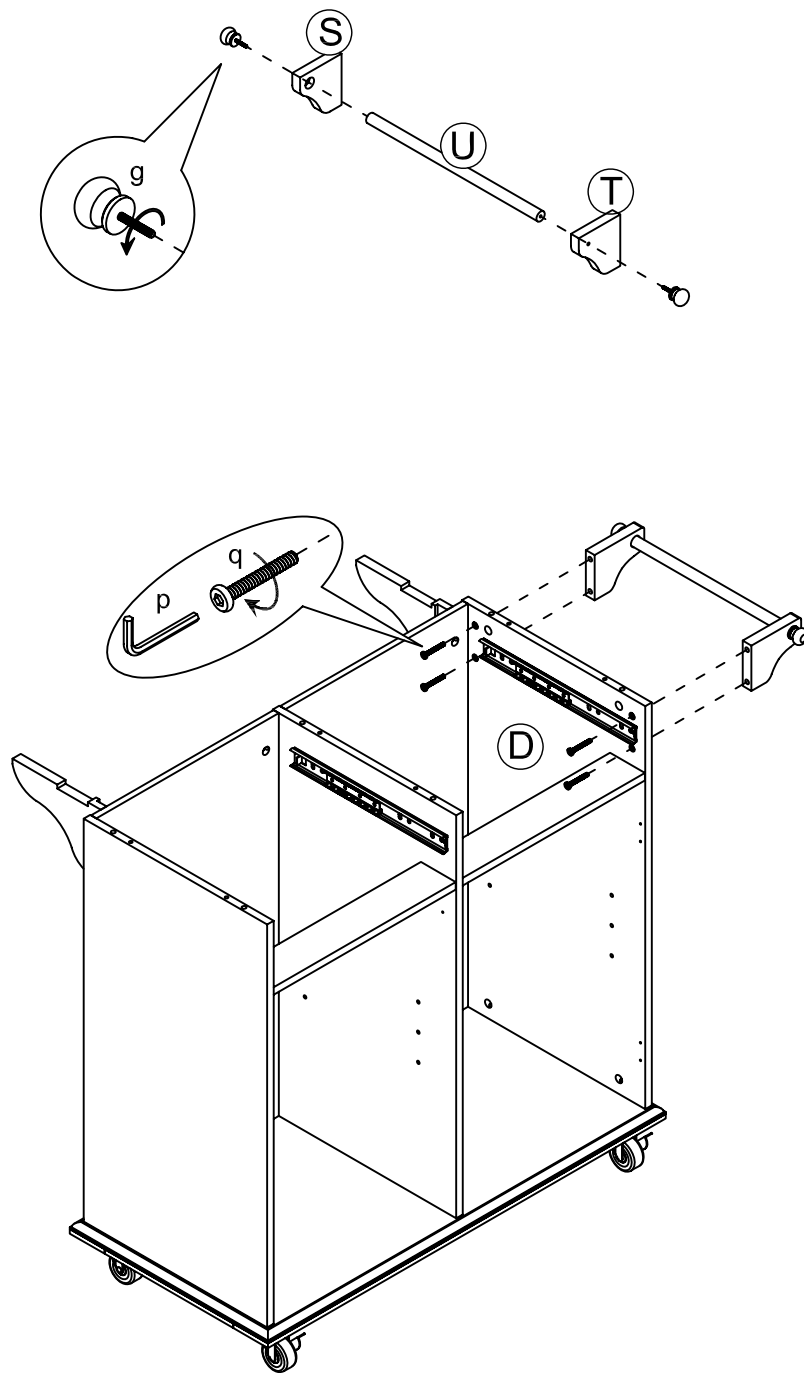

FIG 8

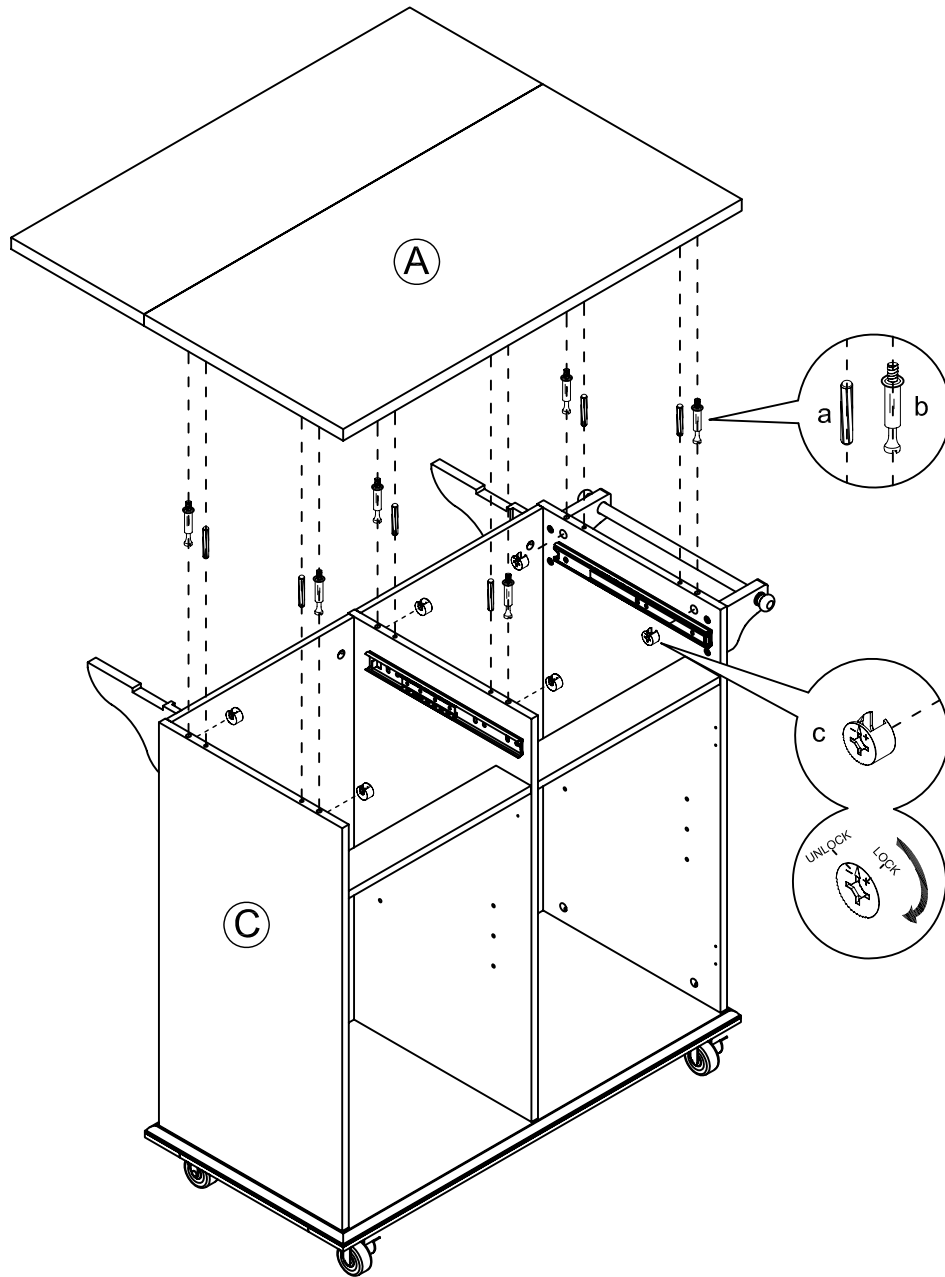

FIG 9

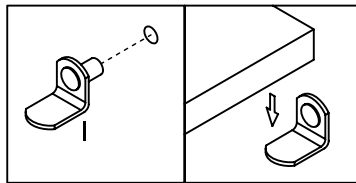
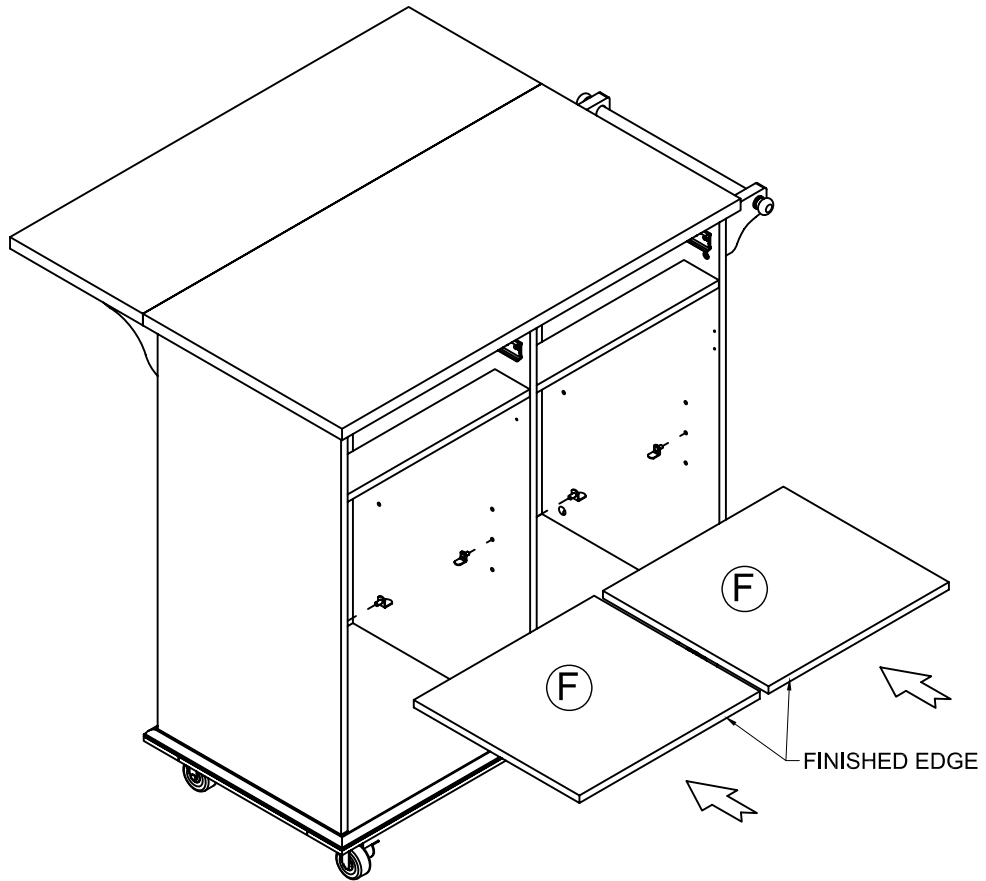

FIG 10

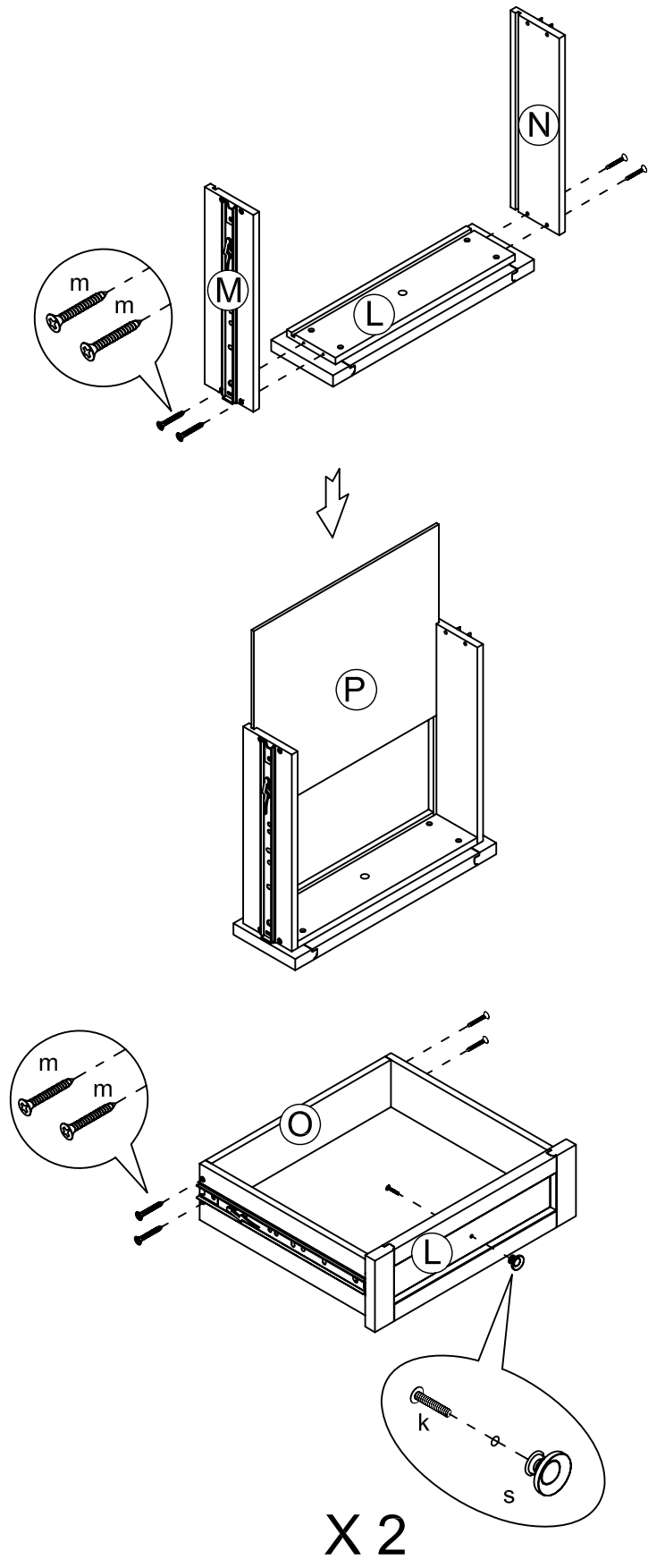

FIG 11

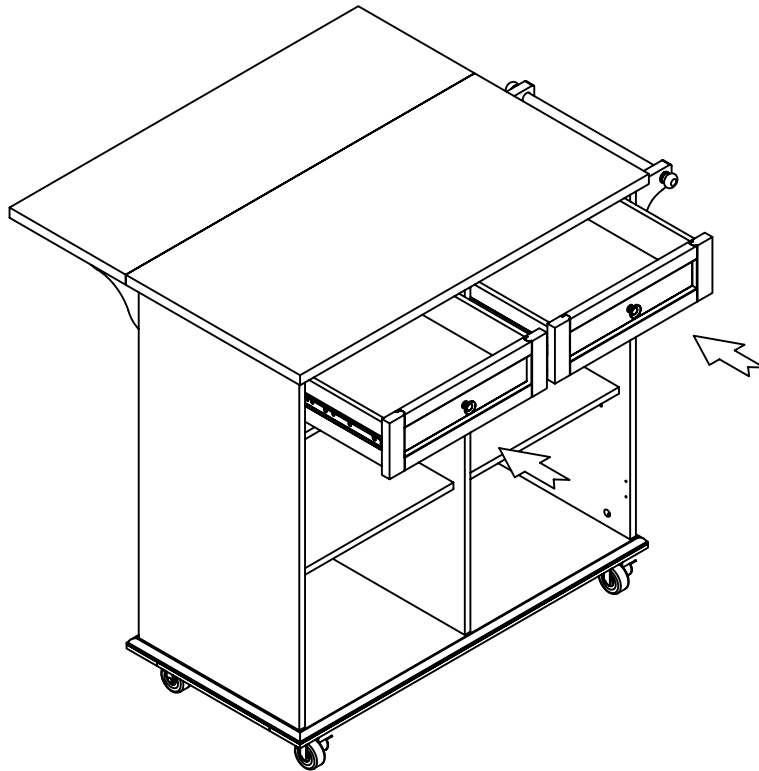

FIG 12

