

DOREL ASIA

FULL/QUEEN METAL HEADBOARD

Model No.:
WM5278Q

UPC CODE:
0-65857-15659-1

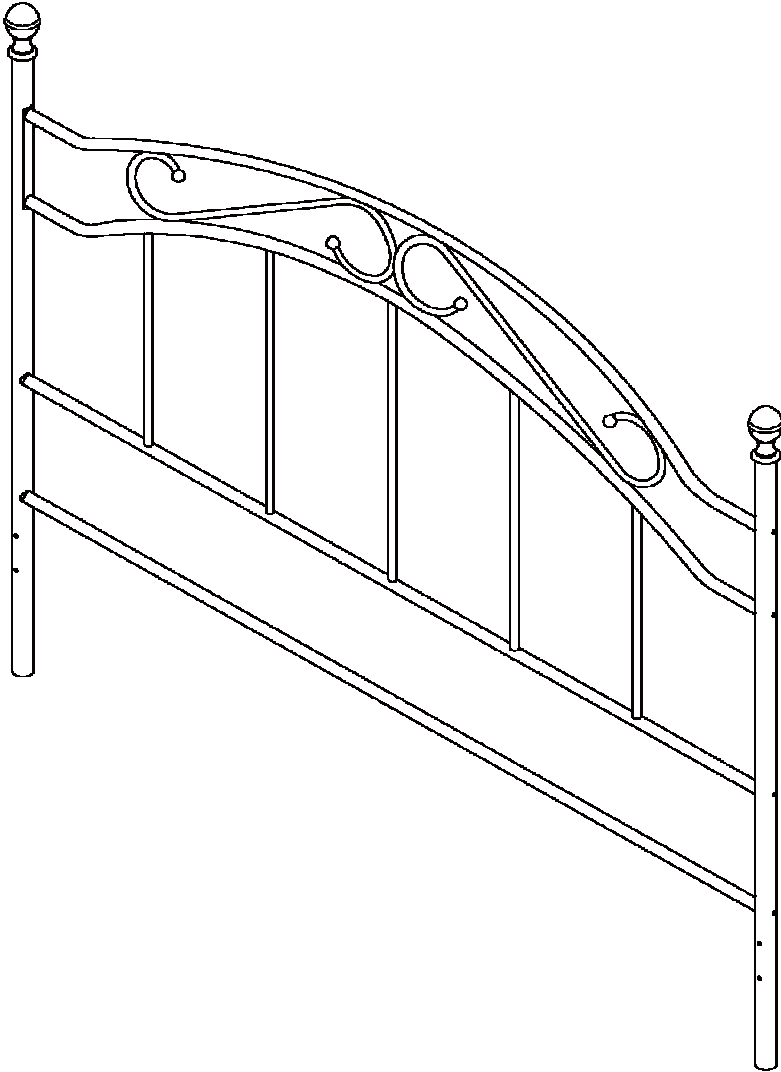

NOTE:

THIS INSTRUCTION BOOKLET
CONTAINS **IMPORTANT** SAFETY
INFORMATION. PLEASE READ AND
KEEP FOR FUTURE REFERENCE.

Lot number:
(TAKEN FROM CARTON)

Date of purchase:
____ / ____ / ____

DO NOT RETURN PRODUCT TO THE STORE.

If a part is missing or damaged, contact our customer service department. We will replace the part **FREE** of charge.



Tel # : 1-800-295-1980
E-Mail: das@dorel.com
Fax #: 514-353-7819

CUSTOMER SERVICE

If you are missing parts or have any questions about this product, contact our customer service representative first!



CALL 1-800-295-1980

You can also order parts by writing to the address listed below. Please include the product model number, color and a detailed description of the part.

**Customer Service Department No. 413
12345 Albert-Hudon Boulevard, Suite 100
Montreal, Quebec
Canada, H1G 3L1**

E-MAIL: das@dorel.com

NOTES

- * Ensure all parts and components are present before beginning assembly.
- * Assemble on a soft, smooth surface to prevent damage to the product finish.
- * Read all instruction before use.
- * **DO NOT** use power tools.
- * **CAUTION:** Adult assembly required.
- * Assembly may require two people.
- * Estimated assembly time: 25 minutes.

NOTE: Bed frame is not included and must be purchased separately.

CARE AND CLEANING

Dust this item regularly with a soft, lint-free cloth to prevent soil build up. Do not soak or wash in hot water. Wipe with a soft, damp cloth if necessary. Do not use abrasives, cleansers or polish.

MAINTENANCE

Check bolts/screws periodically and tighten them if necessary.

LIMITED WARRANTY





DOREL ASIA warrants its product to be free from defects in material and workmanship and agrees to remedy any such defect. This warranty covers 1 year from the date of original purchase. This warranty is valid only upon presentation of proof of purchase. This is solely limited to the repair or replacement of defective furniture components and no assembly labor is included. This warranty does not apply to any product which has been improperly assembled, subjected to misuse or abuse or which has been altered or repaired in any way. This warranty gives you specific legal rights and you may also have other rights which vary from State to State



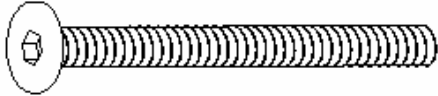

WARNING: Should this product become damaged, and/or components are broken or missing, DO NOT USE.

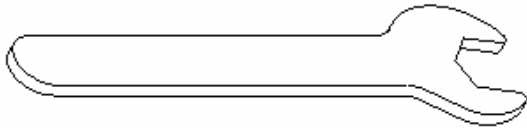
FULL/QUEEN METAL HEADBOARD WM5278Q

HARDWARE LIST



<div style="border: 1px solid black; padding: 5px; margin-bottom: 5px;"> <div style="border: 1px solid black; width: 30px; height: 30px; display: flex; align-items: center; justify-content: center; margin-bottom: 5px;">1</div>  <p style="text-align: center; margin-top: 5px;">$\Phi 1/4" \times 2"$</p> </div> <div style="border: 1px solid black; padding: 5px;"> <p style="text-align: center;">HEX SOCKET HEAD BOLT 12 PCS</p> </div>	<div style="border: 1px solid black; padding: 5px; margin-bottom: 5px;"> <div style="border: 1px solid black; width: 30px; height: 30px; display: flex; align-items: center; justify-content: center; margin-bottom: 5px;">2</div>  <p style="text-align: center; margin-top: 5px;">$\Phi 1/4" \times 1-1/4"$</p> </div> <div style="border: 1px solid black; padding: 5px;"> <p style="text-align: center;">THREADED PIN - 2 PCS</p> </div>
<div style="border: 1px solid black; padding: 5px; margin-bottom: 5px;"> <div style="border: 1px solid black; width: 30px; height: 30px; display: flex; align-items: center; justify-content: center; margin-bottom: 5px;">3</div>  <p style="text-align: center; margin-top: 5px;">HEX KEY 1 PC</p> </div>	<div style="border: 1px solid black; padding: 5px; margin-bottom: 5px;"> <div style="border: 1px solid black; width: 30px; height: 30px; display: flex; align-items: center; justify-content: center; margin-bottom: 5px;">4</div>  <p style="text-align: center; margin-top: 5px;">OPEN END WRENCH 1 PC</p> </div>
<div style="border: 1px solid black; padding: 5px; margin-bottom: 5px;"> <div style="border: 1px solid black; width: 30px; height: 30px; display: flex; align-items: center; justify-content: center; margin-bottom: 5px;">5</div>  <p style="text-align: center; margin-top: 5px;">$\Phi 6.5\text{mm} \times 16\text{mm} \times 1.0\text{mm}$</p> </div> <div style="border: 1px solid black; padding: 5px;"> <p style="text-align: center;">SPRING WASHER 4 PCS</p> </div>	<div style="border: 1px solid black; padding: 5px; margin-bottom: 5px;"> <div style="border: 1px solid black; width: 30px; height: 30px; display: flex; align-items: center; justify-content: center; margin-bottom: 5px;">6</div>  <p style="text-align: center; margin-top: 5px;">$\Phi 1/4" \times 11\text{mm} \times 8\text{mm}$</p> </div> <div style="border: 1px solid black; padding: 5px;"> <p style="text-align: center;">NUT 4 PCS</p> </div>

BED FRAME HARDWARE (FULL SIZE BED)

<div style="border: 1px solid black; padding: 5px; margin-bottom: 5px;"> <div style="border: 1px solid black; width: 30px; height: 30px; display: flex; align-items: center; justify-content: center; margin-bottom: 5px;">7</div>  <p style="text-align: center; margin-top: 5px;">$\Phi 1/2" \times 1/2"$</p> </div> <div style="border: 1px solid black; padding: 5px;"> <p style="text-align: center;">HEX SOCKET HEAD BOLT 4PCS</p> </div>	<div style="border: 1px solid black; padding: 5px; margin-bottom: 5px;"> <div style="border: 1px solid black; width: 30px; height: 30px; display: flex; align-items: center; justify-content: center; margin-bottom: 5px;">8</div>  <p style="text-align: center; margin-top: 5px;">$\Phi 6.5\text{mm} \times 16\text{mm} \times 1.0\text{mm}$</p> </div> <div style="border: 1px solid black; padding: 5px;"> <p style="text-align: center;">SPRING WASHER 4 PCS</p> </div>
<div style="border: 1px solid black; padding: 5px; margin-bottom: 5px;"> <div style="border: 1px solid black; width: 30px; height: 30px; display: flex; align-items: center; justify-content: center; margin-bottom: 5px;">9</div>  <p style="text-align: center; margin-top: 5px;">$\Phi 1/4" \times 11\text{mm} \times 8\text{mm}$</p> </div> <div style="border: 1px solid black; padding: 5px;"> <p style="text-align: center;">NUT 4 PCS</p> </div>	

FULL/QUEEN METAL HEADBOARD WM5278Q

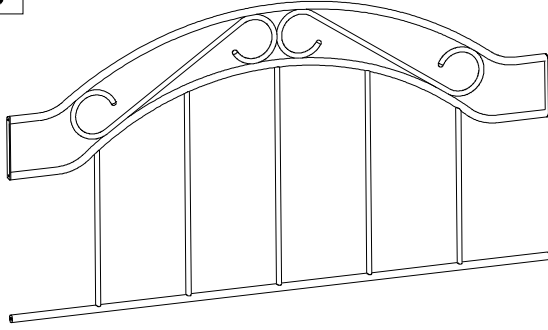
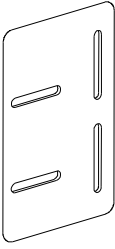
PARTS LIST

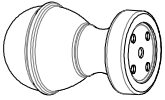
A 	B 	C 
	HEADBOARD - 1 PC	ADAPTER PLATE 2 PCS
	D 	E 
BED POST - 2 PCS	BOTTOM CROSS BAR 1 PC	FINIAL 2 PCS

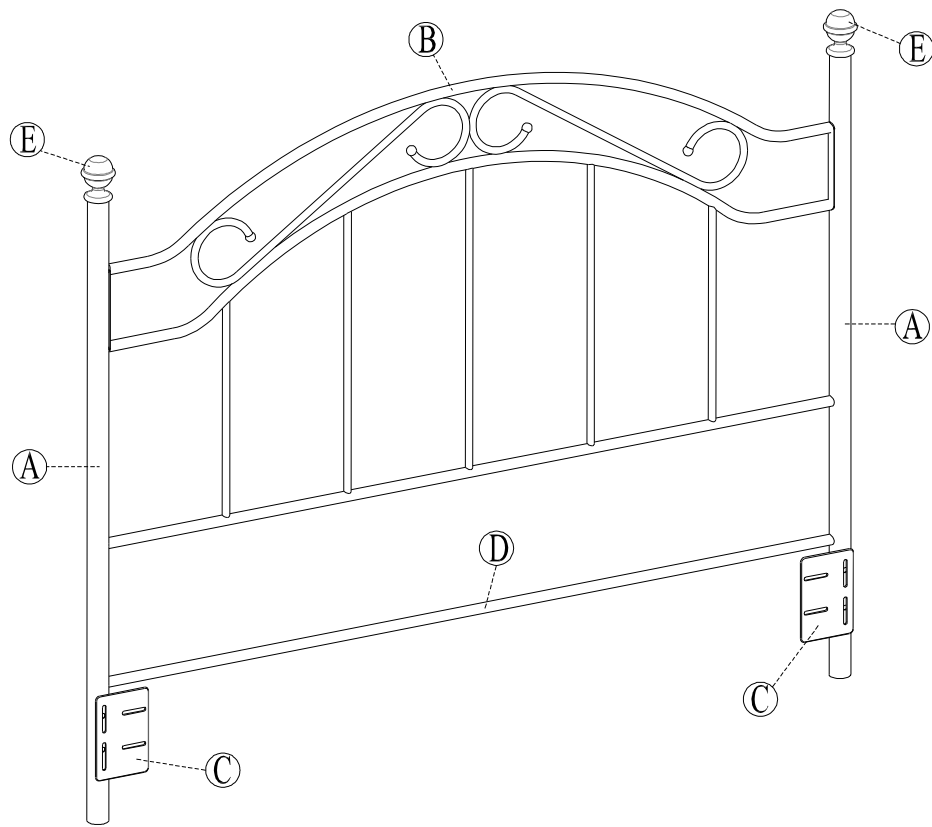

FULL/QUEEN METAL HEADBOARD WM5278Q

STEP 1

Attach finials (E) to bed posts (A) with threaded pins (2).

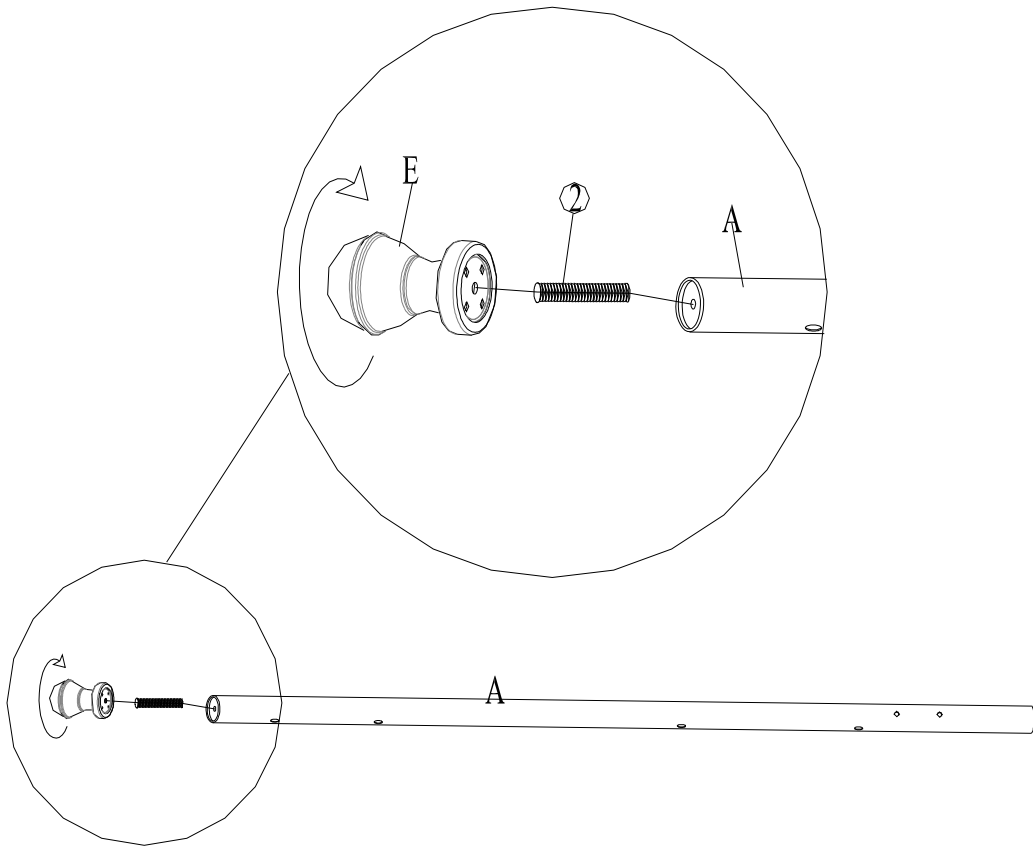

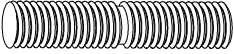
	
②	2 PCS

FULL/QUEEN METAL HEADBOARD WM5278Q

STEP 2

Attach bed posts (A) to headboard (B) and bottom cross bar (D) with hex socket head bolts (1). Leave the bolts loose to facilitate assembly.

Once all bolts are installed, use hex key (3) to tighten bolts (1).

NOTE: Headboard (B) and bottom cross bar (D) must be attached to the countersunk holes on bed posts (A).

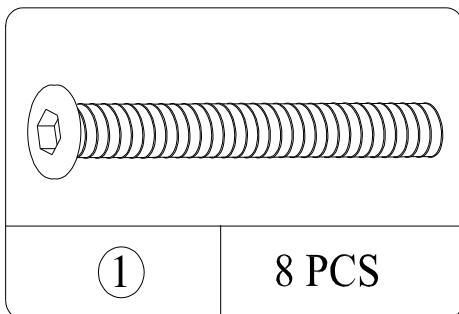
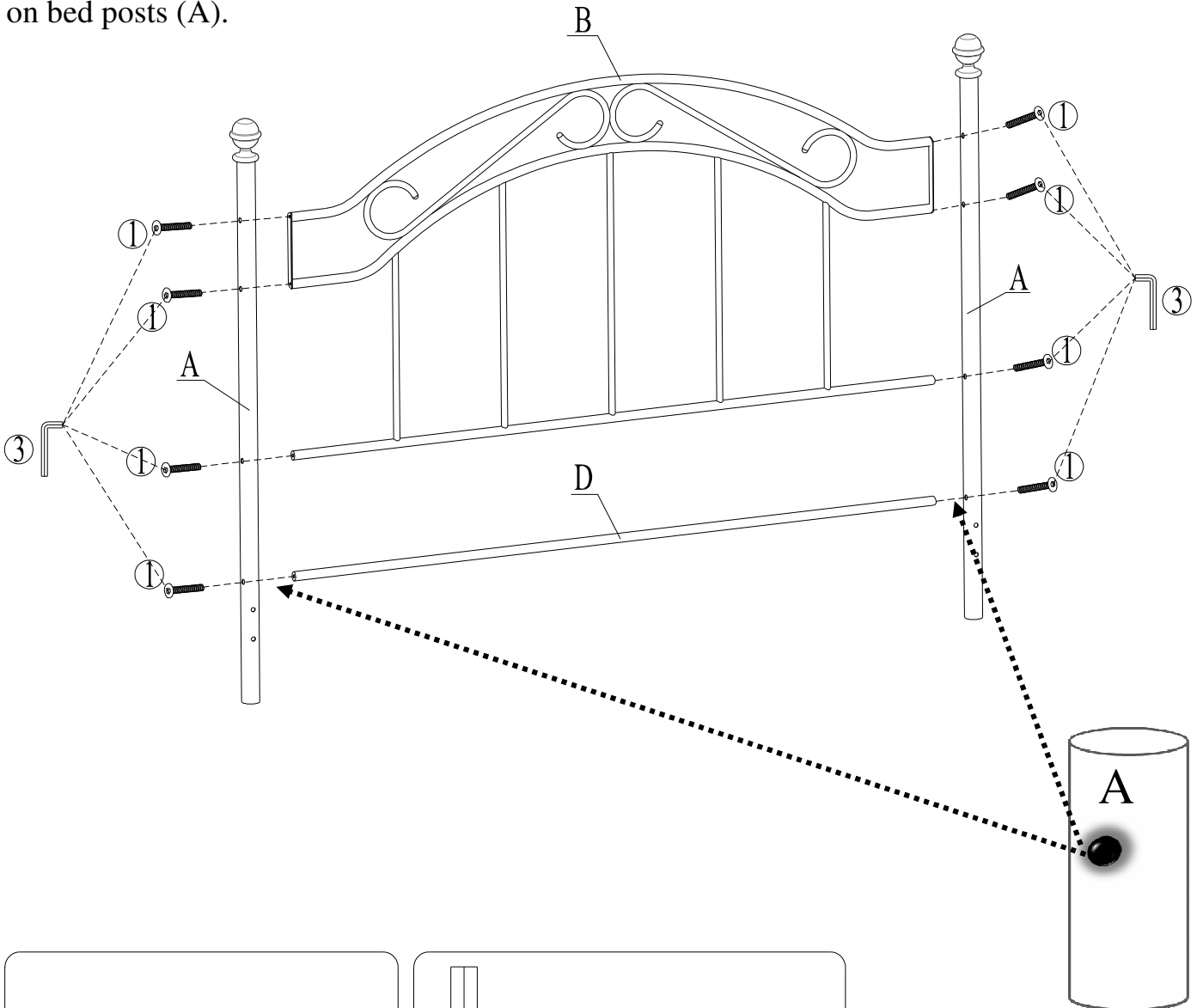

FULL/QUEEN METAL HEADBOARD WM5278Q

NOTE: THE BED FRAME IS NOT INCLUDED AND MUST BE PURCHASED SEPARATELY. THE FOLLOWING ILLUSTRATIONS ARE FOR REFERENCE ONLY.

Attaching the Bed Frame to make a Queen Metal Bed.

Attach bed frame (purchased separately) to bed posts (A) using bolts (1), spring washers (5) and nuts (6). Use hex key (3) to tighten bolts and open end wrench (4) to tighten the nuts.

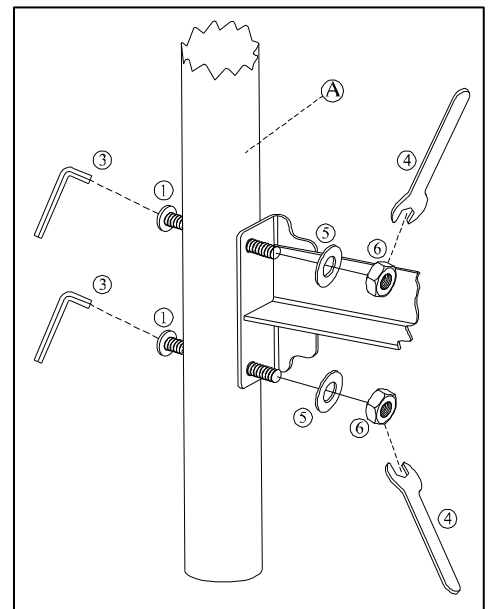
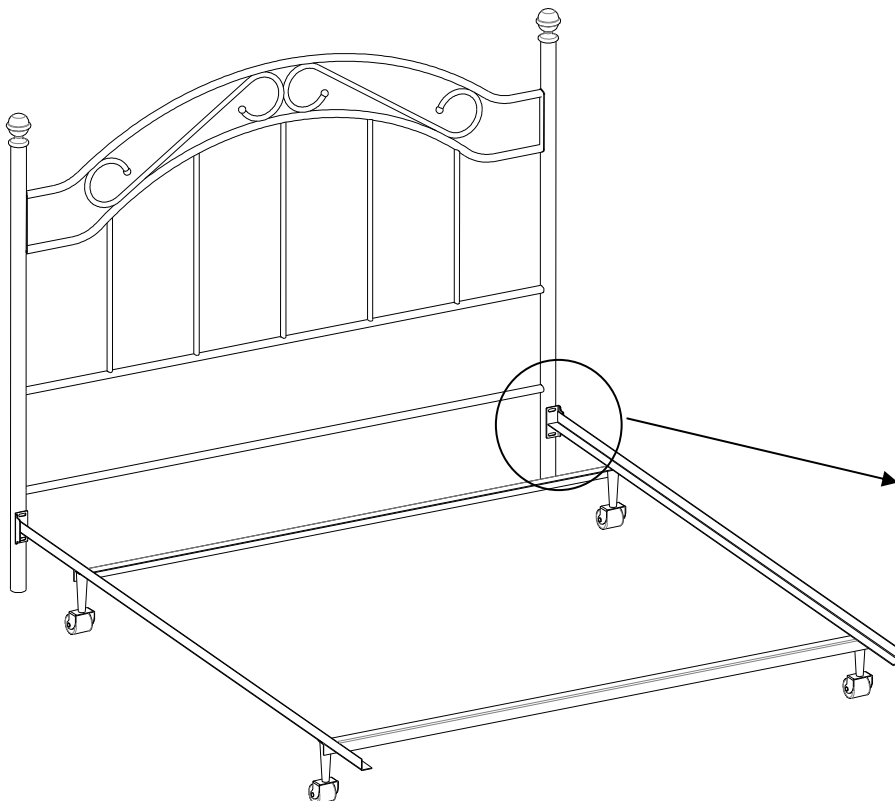
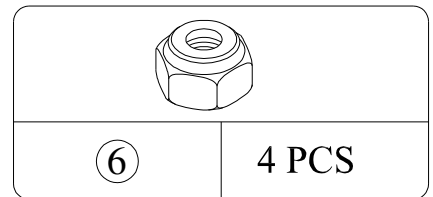
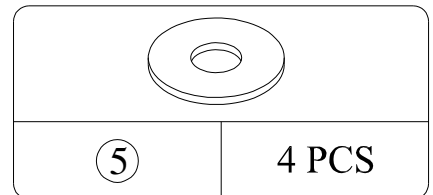
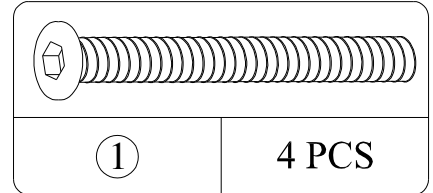
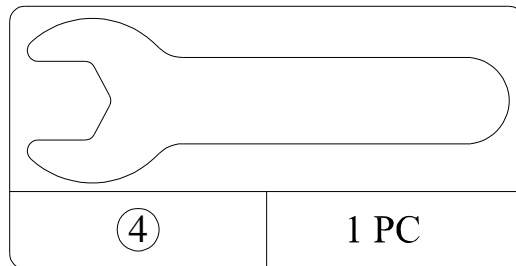
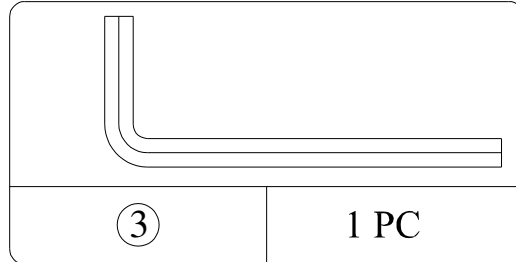

FULL/QUEEN METAL HEADBOARD WM5278Q

Attaching the Bed Frame to make a Full Size Bed

Step 1

Attach adapter plates (C) to bed posts (A) using bolts (1), spring washers (5) and nuts (6). Use hex key (3) to tighten bolts and open end wrench (4) to tighten the nuts.

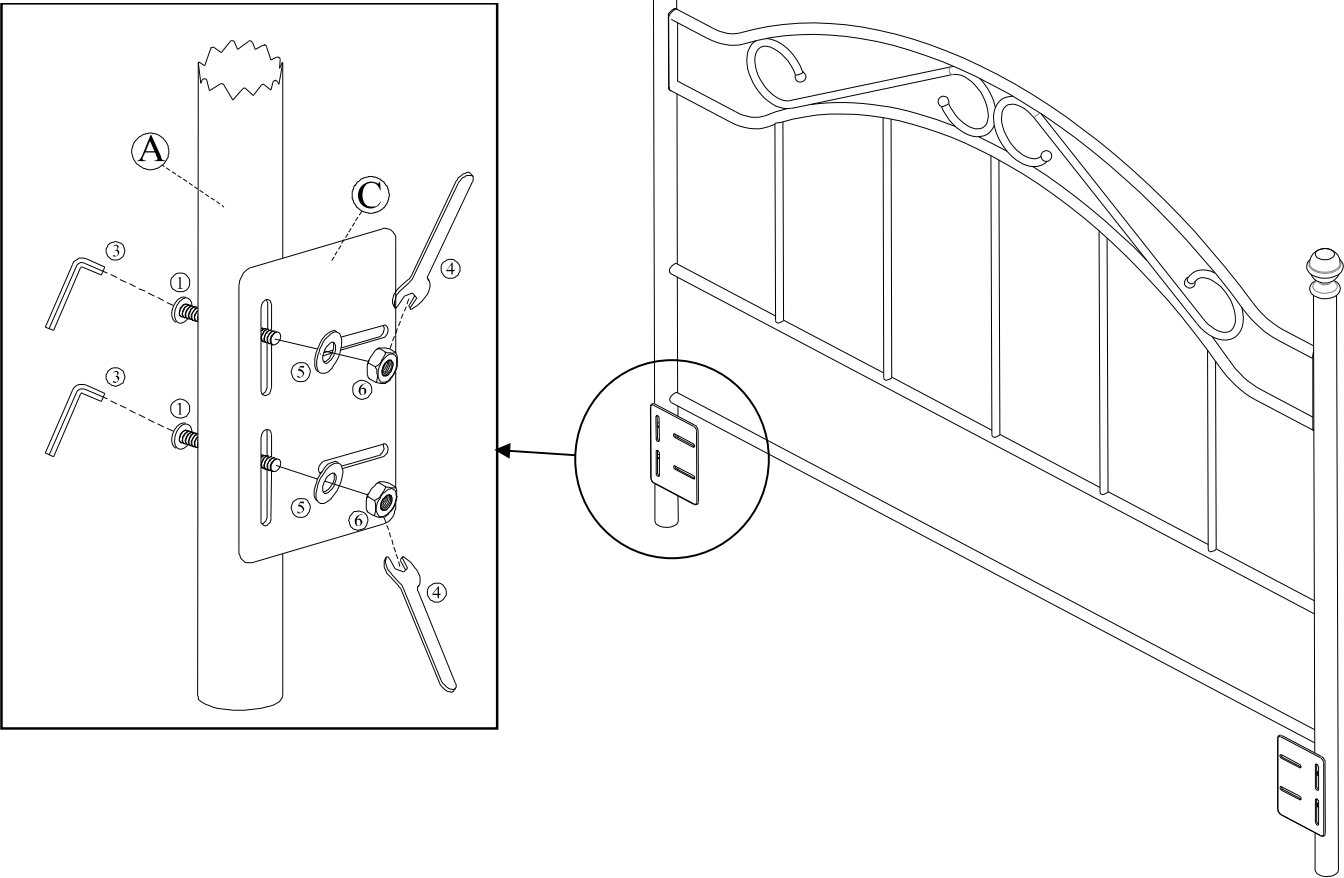
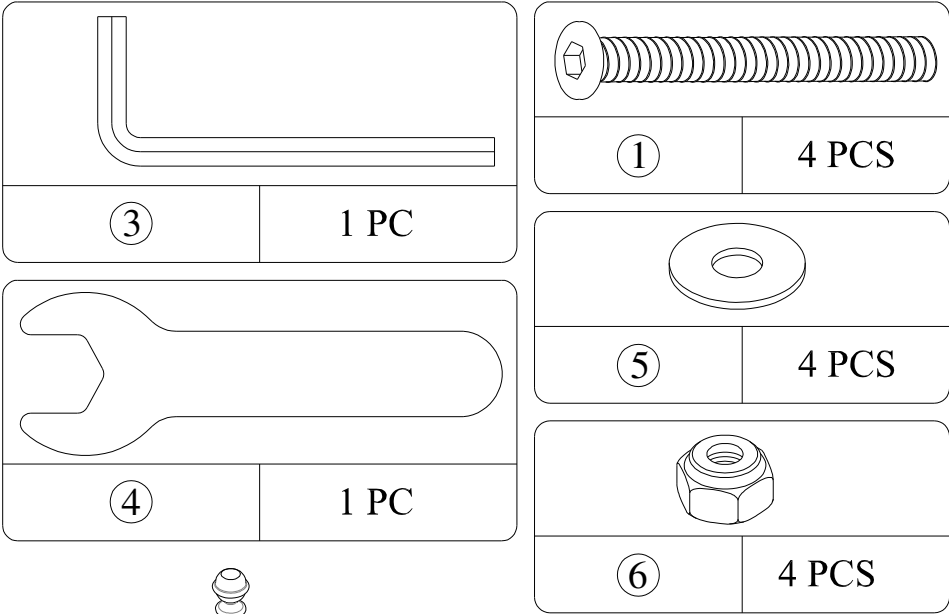

FULL/QUEEN METAL HEADBOARD WM5278Q

NOTE: THE BED FRAME IS NOT INCLUDED AND MUST BE PURCHASED SEPARATELY. THE FOLLOWING ILLUSTRATIONS ARE FOR REFERENCE ONLY.

Step 2

Attach the bed frame (purchased separately) to adapter plate (C) using bolts (7), spring washers (8) and nuts (9). Use hex key (3) to tighten bolts and the open end wrench (4) to tighten the nuts.

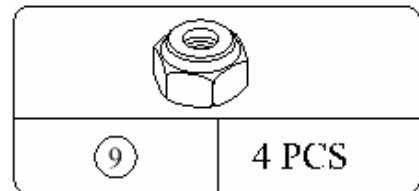
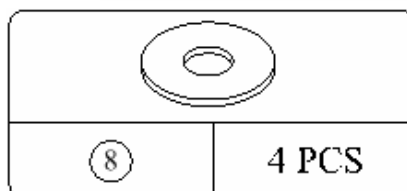
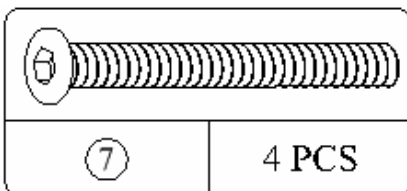
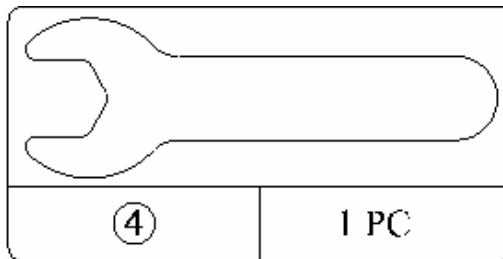
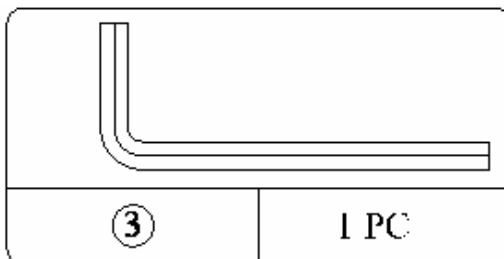
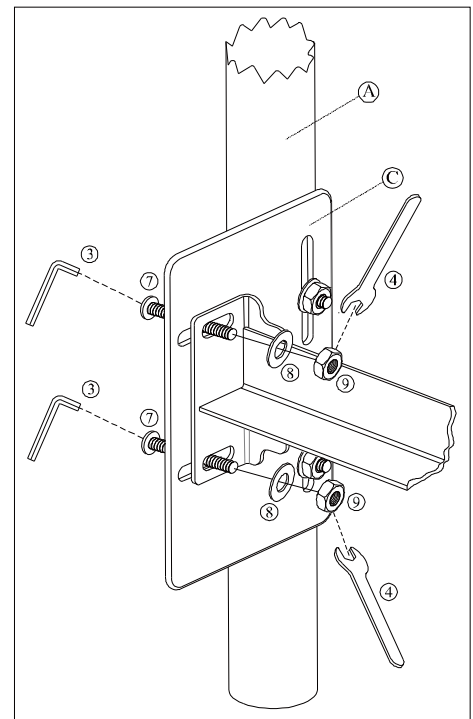
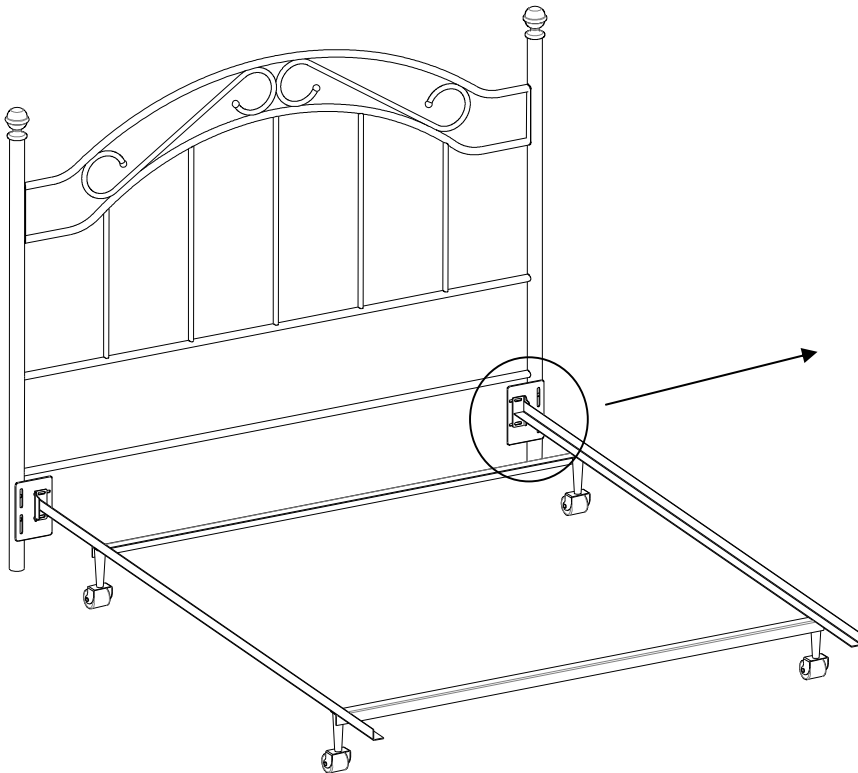

FULL/QUEEN METAL HEADBOARD WM5278Q



CAUTION: This unit is intended for use only with the products and/ or maximum weights indicated. Use with other products and/ or products heavier than the maximum weights indicated may result in instability or cause possible injury.

Dust this item regularly with a soft, lint-free cloth to prevent soil build up. Do not soak or wash in hot water. Wipe with a soft, damp cloth if necessary. Do not use abrasives, cleansers or polish.

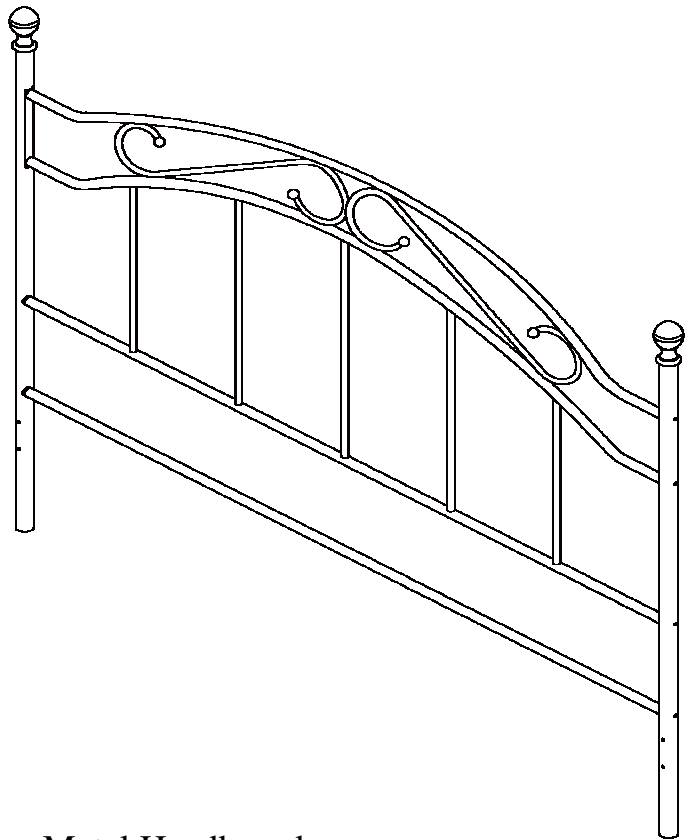

That's it! You've finished assembling your Metal Headboard.

DO NOT RETURN PRODUCT TO THE STORE.

If a part is missing or damaged, Contact our customer service department. We will replace the part **FREE** of charge.



Tel # : 1-800-295-1980
E-Mail: das@dorel.com
Fax #: 514-353-7819

Also available at Walmart & Walmart.com

Mainstays Adjustable Metal Bed Frame

Model # 3215098W / MS12-084-006-10

- 9 Gliders and Headboard attachment included
- Fits all standard headboards

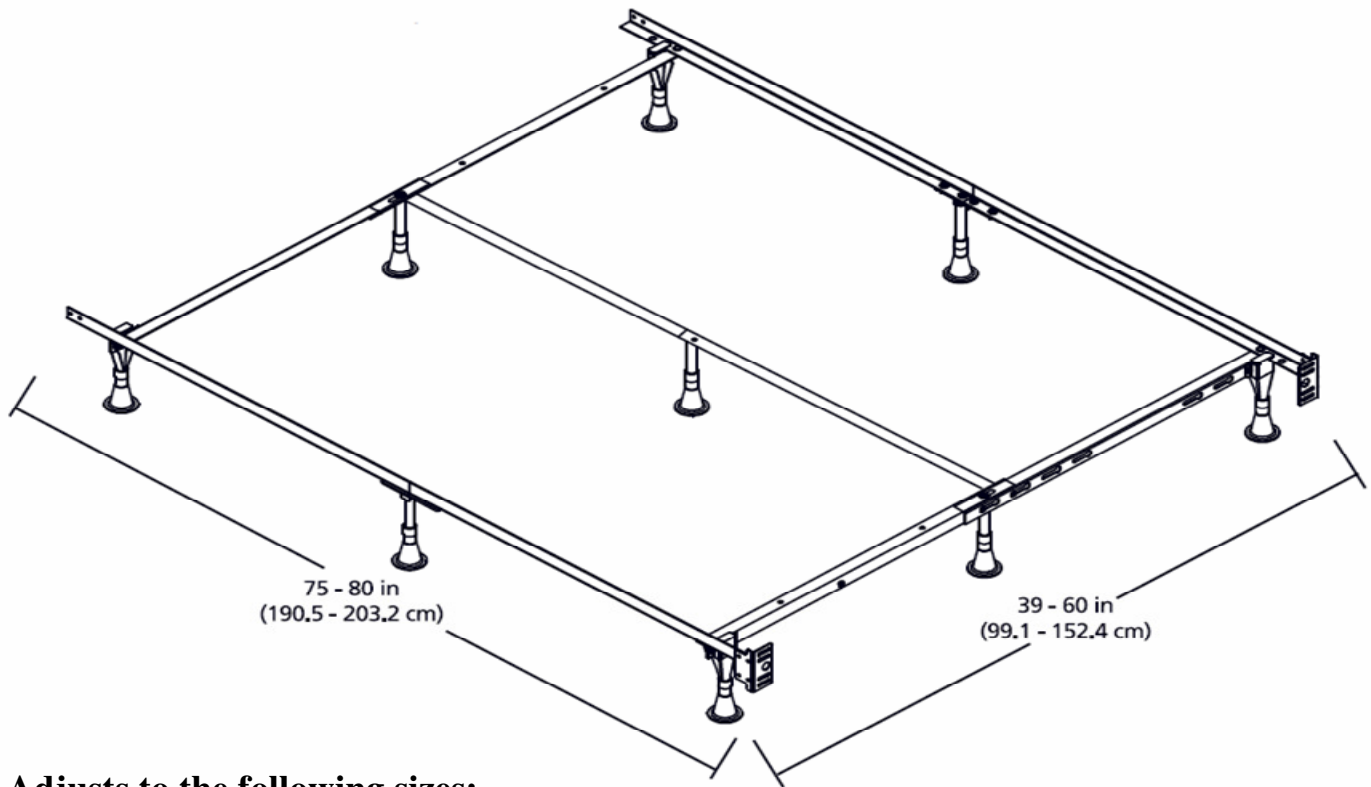

Adjusts to the following sizes:

- Twin - 39 in x 75 in
- Full - 54 in x 75 in
- Queen - 60 in x 80 in

Customer Service

PLEASE DO NOT RETURN THIS PRODUCT TO THE STORE

PLEASE CONTACT CUSTOMER SERVICE REPRESENTATIVES AT THE FOLLOWING NUMBERS SHOULD THERE BE ANY MISSING OR DEFECTIVE PART(S).

Customer Service Phone Number 1-800-295-1980

Email: das@dorel.com

Customer Service Fax Number 514-353-7819

Request Date:

Name:

Shipping Address:

Street & Number:

City & State:

Zip Code:

Day Time Phone Number:
(including area code)

Date & Place of Purchase:

Part(s) description and quantity: (Please be sure to list model number or SKN number)

Customer Service Representative Mailing Address:

Customer Service Department No. 413, 12345 Albert-Hudon Boulevard, Suite 100, Montreal, QC, Canada, H1G 3L1