

ProLED® HID Retrofit Installation Instructions



- Please read the below articles carefully to see how to use this product safely.
- Warning contents and attention contents related to product safety use, please be sure to follow it.

WARNING - Follow the installation instructions to install correctly.

- Disconnect power at the source before installation, inspection or removal. Do not simply switch off fixture.
- This item is rated at 120-277VAC/100-240VAC. Installer must determine whether line voltage 120-277VAC/100-240VAC is available at the luminaire before installation.
- Not intended for use with emergency exit fixtures or emergency exit lights.
- Not for use with luminaire ballast.
- Do not use if product is damaged.
- This lamp is non-dimmable. Not for use with dimmer.
- Do not make or alter any open holes in an enclosure of wiring or electrical components during kit installation.
- Risk of fire or electric shock. Do not open or modify. No user serviceable parts inside.
- Installers should not disconnect existing wires from lamp holder terminals to make new connections at lamp holder terminals. Instead installers should cut existing lamp holder leads away from the lamp holder and make new electrical connections to lamp holder lead wires by employing applicable connections.
- Suitable for damp locations. Suitable for use in wet locations when used in an outdoor -rated fixture. Not for use where directly exposed to the weather or water
- Complies with part 15 of FCC. Operation is subject to the following two conditions: (1) This device may not cause harmful interference , and (2) This device must accept any interference received including interference that may cause undesired operation.
- No external weight or mechanical force should be applied to lamp or components.

• THE RETROFIT ASSEMBLY IS ACCEPTED AS A COMPONENT OF A LUMINAIRE WHERE THE SUITABILITY OF THE COMBINATION SHALL BE DETERMINED BY UL OR AUTHORITIES HAVING JURISDICTION.

Product Dimension

1. Turn off the power to the fixture.
2. Remove existing HID lamp from the fixture.
3. Open the fixture 's junction box and bypass the HID ballast , igniter (If there) and the capacitor (If there) by disconnecting the line and neutral wires and socket black and white wires in the locations with "Cross" marks in the schematic diagram. Then connect the line to the black wire from the socket and the neutral to the white wire from the socket with wire nuts or connectors.
4. 'This luminaire has been modified to operate LED lamps' shall be marked on the retrofit luminaire where readily visible by the user during normal maintenance including re-lamping.

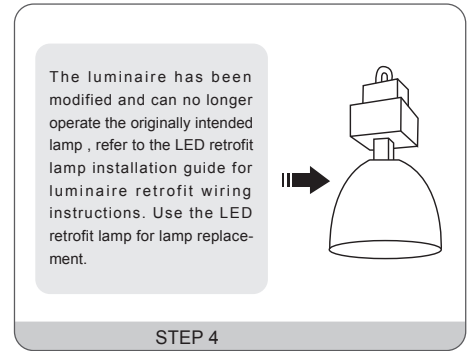
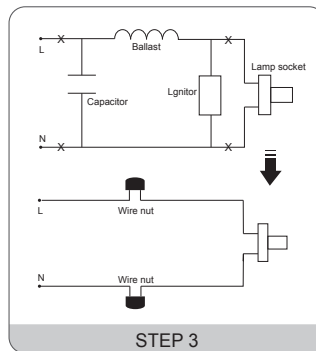
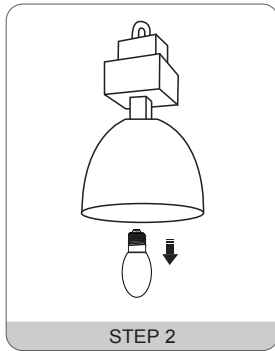
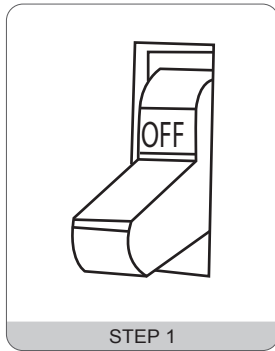

5. Install LED lamp into the socket.

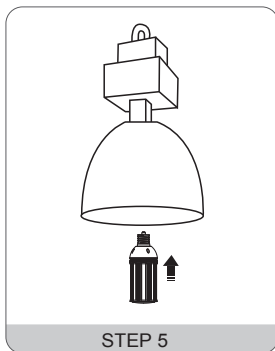

6. Turn on the power to the fixture.



Warranty Information:

This product is warranted for five years from the date of purchase.

If this product does not perform to the specifications supplied on this package, send an email or write to the address below for product return and replacement. This replacement is the sole remedy available. Liability for incidental or consequential damage is expressly excluded.

Visit www.halcolighting.com for full warranty details and compatibility information.