



# Parts Manual

Mfg. No: 020602-00  
1,800 PSI Briggs & Stratton



---

| Model Components                | Page |
|---------------------------------|------|
| Main Unit (80013107).....       | 4    |
| Torque Specification Chart..... | 6    |

Not For  
Reproduction

# Main Unit (80013107)

Note: Unless noted otherwise, use the standard torque specifications

Mfg. No: 020602-00

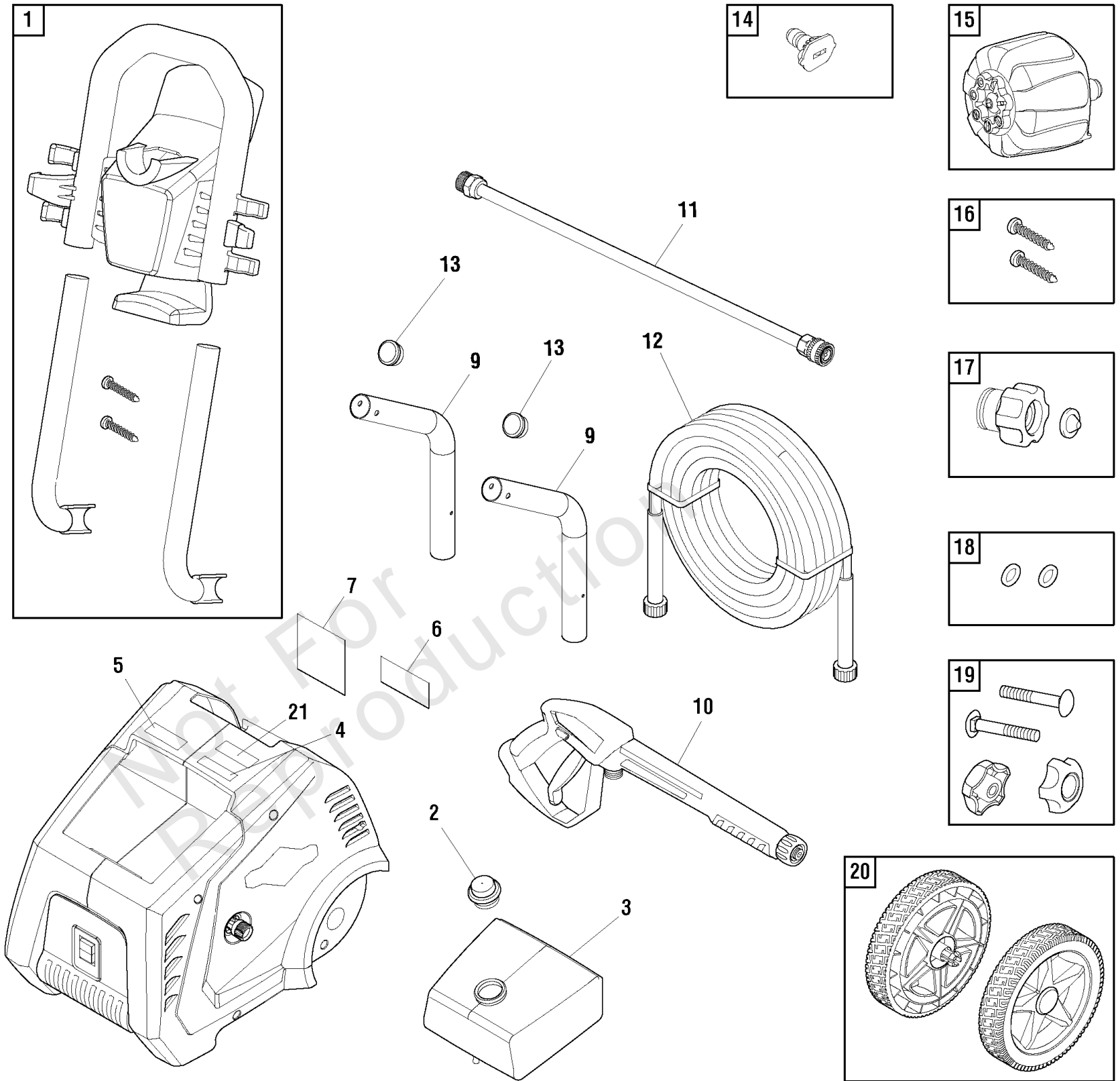

## Main Unit (80013107)

| REF NO | PART NO  | QTY | DESCRIPTION   |
|--------|----------|-----|---|
| 1      | 707472   |     | KIT-HANDLE  |
| 2      | 705369   |     | CAP   |
| 3      | 707001   |     | TANK-CHEMICAL                                       |
| 4      | 316391GS |     | DECAL   |
| 5      | 705745   |     | DECAL   |
| 6      | 205008GS |     | DECAL   |
| 7      | 707163   |     | DECAL   |
| 9      | 707161   |     | TUBE-SUPPORT  |
| 10     | 705838   |     | GUN   |
| 11     | 705373   |     | WAND  |
| 12     | 707003   |     | HOSE  |
| 13     | 707159   |     | CAP-END   |
| 14     | 707162   |     | NOZZLE  |
| 15     | 317349GS |     | NOZZLE-MULTI TIP                                    |
| 16     | 707158   |     | KIT-HANDLE HARDWARE                                 |
| 17     | 317429GS |     | ADAPTER   |
| --     | B2384GS  |     | FILTER-GARDEN HOSE                                  |
| 18     | 707005   |     | KIT-O-RINGS   |
| 19     | 707002   |     | HANDLE-HARDWARE                                     |
| 20     | 707004   |     | KIT-WHEEL   |
| 21     | 316607GS |     | DECAL   |
| --     | 317426GS |     | DECAL-WARNING, CORD<br>-(Not Illustrated)           |
| --     | 707740   |     | WIRE-CLEANING<br>-(Not Illustrated)                 |
| --     | 705001   |     | KIT-O-RINGS<br>-(Optional Accessory - Not Included) |

# Hardware Identification & Torque Specifications

| Torque Specification Chart                             |           |      |           |      |            |      |            |      |
|--|-----------|------|-----------|------|------------|------|------------|------|
| FOR STANDARD METRIC MACHINE HARDWARE (Tolerance ± 20%) |           |      |           |      |            |      |            |      |
| Property Class   | 5.6       |      | 8.8       |      | 10.9       |      | 12.9       |      |
|  | Class 5.6 |      | Class 8.8 |      | Class 10.9 |      | Class 12.9 |      |
| Size Of Hardware                                       | in/lbs    | Nm.  | in/lbs    | Nm.  | in/lbs     | Nm.  | in/lbs     | Nm.  |
|  | ft/lbs    |      | ft/lbs    |      | ft/lbs     |      | ft/lbs     |      |
| M3   | 5.88      | .56  | 13.44     | 1.28 | 19.2       | 1.80 | 22.92      | 2.15 |
| M4   | 13.44     | 1.28 | 30.72     | 2.90 | 43.44      | 4.10 | 52.56      | 4.95 |
| M5   | 26.4      | 2.50 | 60.96     | 5.75 | 5.97       | 8.10 | 7.15       | 9.7  |
| M6   | 44.64     | 4.3  | 7.3       | 9.9  | 10.3       | 14   | 12.1       | 16.5 |
| M7   | 5.2       | 7.1  | 12.1      | 16.5 | 16.9       | 23   | 19.9       | 27   |
| M8   | 7.7       | 10.5 | 17.7      | 24   | 25         | 34   | 29         | 40   |
| M10  | 15        | 21   | 35        | 48   | 50         | 67   | 59         | 81   |
| M12  | 26        | 36   | 61        | 83   | 86.2       | 117  | 103        | 140  |
| M14  | 42        | 58   | 101       | 132  | 136        | 185  | 162        | 220  |
| M16  | 64        | 88   | 147       | 200  | 210        | 285  | 250        | 340  |
| M18  | 89        | 121  | 202       | 275  | 287        | 390  | 346        | 470  |
| M20  | 126       | 171  | 290       | 390  | 405        | 550  | 486        | 660  |
| M22  | 169       | 230  | 390       | 530  | 559        | 745  | 656        | 890  |
| M24  | 217       | 295  | 497       | 375  | 708        | 960  | 840        | 1140 |
| M27  | 320       | 435  | 733       | 995  | 1032       | 1400 | 1239       | 1680 |
| M30  | 435       | 590  | 995       | 1350 | 1401       | 1900 | 1681       | 2280 |
| M33  | 590       | 800  | 1349      | 1830 | 1902       | 2580 | 2278       | 3090 |
| M36  | 759       | 1030 | 1740      | 2360 | 2441       | 3310 | 2935       | 3980 |
| M39  | 988       | 1340 | 2249      | 3050 | 3163       | 4290 | 3798       | 5150 |

| Torque Specification Chart                      |             |       |             |       |             |         |
|---|-------------|-------|-------------|-------|-------------|---------|
| FOR STANDARD MACHINE HARDWARE (Tolerance ± 20%) |             |       |             |       |             |         |
| Hardware Grade                                  | No Marks    |       | SAE Grade 5 |       | SAE Grade 8 |         |
|   | SAE Grade 2 |       | SAE Grade 5 |       | SAE Grade 8 |         |
| Size Of Hardware                                | in/lbs      | Nm.   | in/lbs      | Nm.   | in/lbs      | Nm.     |
|   | ft/lbs      |       | ft/lbs      |       | ft/lbs      |         |
| 8-32  | 19          | 2.1   | 30          | 3.4   | 41          | 4.6     |
| 8-36  | 20          | 2.3   | 31          | 3.5   | 43          | 4.9     |
| 10-24   | 27          | 3.1   | 43          | 4.9   | 60          | 6.8     |
| 10-32   | 31          | 3.5   | 49          | 5.5   | 68          | 7.7     |
| 1/4-20  | 66          | 7.6   | 8           | 10.9  | 12          | 16.3    |
| 1/4-28  | 76          | 8.6   | 10          | 13.6  | 14          | 19.0    |
| 5/16-18   | 11          | 15.0  | 17          | 23.1  | 25          | 34.0    |
| 5/16-24   | 12          | 16.3  | 19          | 25.8  | 29          | 34.0    |
| 3/8-16  | 20          | 27.2  | 30          | 40.8  | 45          | 61.2    |
| 3/8-24  | 23          | 31.3  | 35          | 47.6  | 50          | 68.0    |
| 7/16-14   | 30          | 40.8  | 50          | 68.0  | 70          | 95.2    |
| 7/16-20   | 35          | 47.6  | 55          | 74.8  | 80          | 108.8   |
| 1/2-13  | 50          | 68.0  | 75          | 102.0 | 110         | 149.6   |
| 1/2-20  | 55          | 74.8  | 90          | 122.4 | 120         | 163.2   |
| 9/16-12   | 65          | 88.4  | 110         | 149.6 | 150         | 204.0   |
| 9/16-18   | 75          | 102.0 | 120         | 163.2 | 170         | 231.2   |
| 5/8-11  | 90          | 122.4 | 150         | 204.0 | 220         | 299.2   |
| 5/8-18  | 100         | 136   | 180         | 244.8 | 240         | 326.4   |
| 3/4-10  | 160         | 217.6 | 260         | 353.6 | 386         | 525.0   |
| 3/4-16  | 180         | 244.8 | 300         | 408.0 | 420         | 571.2   |
| 7/8-9   | 140         | 190.4 | 400         | 544.0 | 600         | 816.0   |
| 7/8-14  | 155         | 210.8 | 440         | 598.4 | 660         | 897.6   |
| 1-8   | 220         | 299.2 | 580         | 788.8 | 900         | 1,244.0 |
| 1-12  | 240         | 326.4 | 640         | 870.4 | 1,000       | 1,360.0 |

The guides and ruler furnished below are designed to help you select the appropriate hardware.



Nut, M8

Thread Diameter (mm)

Inside Diameter (in)      Threads per inch

Nut, 1/2-16

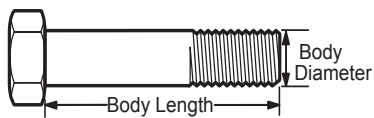

Screw, M8- 1.25 x 25

Thread Diameter (mm)      Distance between threads (mm)      Body Length (mm)

Body Diameter      Threads per inch      Body Length (in)

Screw, 1/2- 16 x 2



## Standard Hardware Sizing

When a washer or nut is identified as 1/2" (M8), this is the *Nominal size*, meaning the *inside diameter* is 1/2 inch (8mm metric thread diameter); if a second number is present it represents the *threads per inch* (distance between threads).

When bolt or capscrew is identified as 1/2 - 16 x 2" (M8 - 1.25 x 50), this means the *Nominal size*, or body diameter is 1/2 inch (8mm metric thread diameter), the second number, 16, represents the *threads per inch*, (*distance between threads*). The final number is the body length of the bolt or screw, 2 inches (50mm).

## NOTES

- These torque values are to be used for all hardware excluding: locknuts, self-tapping screws, thread forming screws, sheet metal screws and socket head setscrews.
- Recommended seating torque values for locknuts:
  - for prevailing torque locknuts - use 65% of grade 5 torques.
  - for flange whizlock nuts and screws - use 135% of grade 5 torques.
- Unless otherwise noted on assembly drawings, all torque values must meet this specification.

## Common Hardware Types

Hex Head Capscrew



Washer



Carriage Bolt



Hex Nut

## Wrench & Fastener Size Guide

|                                  |                                  |                                  |  |                                 |
|----------------------------------|----------------------------------|----------------------------------|--|---------------------------------|
|                                  |                                  |                                  |  |                                 |
| 1/4" Bolt or Nut<br>Wrench—7/16" | 5/16" Bolt or Nut<br>Wrench—1/2" | 3/8" Bolt or Nut<br>Wrench—9/16" | 7/16" Bolt or Nut<br>Wrench (Bolt)—5/8"<br>Wrench (Nut)—11/16" | 1/2" Bolt or Nut<br>Wrench—3/4" |
| M6 Bolt or Nut<br>Wrench—10mm    | M8 Bolt or Nut<br>Wrench—13mm    | M10 Bolt or Nut<br>Wrench—17mm   | M12 Bolt or Nut<br>Wrench—19mm                                 | M14 Bolt or Nut<br>Wrench—22mm  |

