

LIFETIME RESIDENTIAL WARRANTY PROGRAM

ENGINEERED PREFINISHED HARDWOOD FLOORING

The limited warranties set forth below apply only to pre-finished products and are effective with purchases made after February 8, 2018. All warranties are limited to the original purchaser only.

FINISH WARRANTY

Flooring Manufacturer warrants that the finish will not wear through to the wood for **Lifetime** as long as the original purchaser owns the floor, whichever is less. Please refer to the individual product brochure for more information on your particular product. EXCLUSIONS AND LIMITATIONS DO APPLY. SEE BELOW FOR DETAILS.

MATERIAL WARRANTY

Flooring Manufacturer warrants that the products have been manufactured in compliance with the grading rules of flooring manufacturer, and will be free from manufacturing defects for as long as the original purchaser owns the floor. Manufacturing defects do not include natural wood characteristics such as mineral streaks, knots, grain variations, normal minor differences between color of samples and the color of installed floors, color variations from board to board, or minor width variation. Due to the nature of wide width plank (3" and wider), some minor width variation is to be expected and is not considered a defect.

EXCLUSIONS AND LIMITATIONS

These warranties do not cover damage, indentations, scratches, or stains arising from negligence, accidents, abuse, fire or excessive heat, abnormal wear, construction, spike heels, grit, sand or other abrasives, dents, insect infestation after the product has left our factory, or domestic animals. Splits and cracks after move-in are not normally manufacturer related.

These warranties do not cover damage caused by use of the flooring for purposes other than those for which it was designed; damage caused by disasters such as fire, flood, wind, and lightning; damage during shipment; or any other abuse or misuse by the purchaser.

It is critical that all installations are done in compliance with the procedures outlined in the flooring manufacturer installation instructions, which can be found in each carton of flooring. No damage or defects caused by improper installation or failure to provide a suitable installation environment are covered by this warranty. Failure to install your flooring in accordance with the instructions will void all warranties.

The sole obligation and liability of the flooring manufacturer under our limited warranties is to repair, replace or refinish the floor at the flooring manufacturer's option. Only floors that were professionally installed will be eligible for labor cost reimbursement. If you installed the floor yourself, we will cover the cost of replacement materials only. (Any and all labor costs must be pre-approved by the flooring manufacturer Claims Department.)

These warranties EXCLUDE and will not pay consequential or incidental damages associated with any warranty claim. Flooring manufacturer will not pay costs associated with relocation during the repair process such as hotel, meals, or moving and storage of furniture. This limitation does not apply to claims for personal injury. Some states do not allow limits on warranties, or on remedies for breach in certain transactions. In such states, the limits in this paragraph may not apply.

No warranty coverage is provided for flooring that contains obvious defects of any kind that were installed nonetheless. If, before installation, you discover any flooring that has obvious defects, please immediately contact the dealer from whom the flooring was purchased and replacement flooring will be provided at no cost.

Only Flooring Manufacturer approved cleaning products are appropriate for use on Flooring Manufacturer products. Use of non-Flooring Manufacturer approved cleaning and maintenance products, including oil soap or ammonia based products, will void all warranties. For a current list of approved products, please call your local dealer or wood distributor.

The limited warranties do not cover color changes to any flooring which results from exposure to UV light. Normal exposure to sunlight will cause changes in the shading of any wood floor, and this is not considered a defect. Certain species including, but not limited to, American Cherry, Walnut, Brazilian Cherry, Tigerwood, and most Exotics, are especially susceptible to color change. Please contact your flooring retailer for more information. Area rugs should be moved occasionally, as they block sunlight and may give the appearance of discoloration under the rug.

After your floor is installed, it is critical to maintain the temperature and humidity of the home within the ranges set forth in the applicable installation instructions for the product. Failure to follow these guidelines, especially with regard to humidity range, can result in a performance failure or damage to your floor. In addition, it is important to maintain your floor in accordance with the flooring manufacturer maintenance instructions.

These warranties do not cover damage or unsatisfactory performance caused by excessive moisture or moisture vapor including, but not limited to, improper humidity inside the home, excessive ground moisture that migrates into the home for any reason, excessive sub-floor moisture, water leaks caused by broken pipes or appliances, improper cleaning methods such as wet mopping or automated cleaning machines, weather conditions or natural disasters such as flooding or excessive rainfall.

Since wood is a natural product, it will tend to expand and contract as moisture and humidity levels inside the home may change. Accordingly, normal expansion and contraction which results in minor separations between flooring boards are not covered by these warranties.

Any flooring manufacturer product which is designated as "cabin grade", "tavern grade", "second", or "as is" is not covered by the above warranties.

THERE ARE NO WARRANTIES WHICH EXTEND BEYOND THE DESCRIPTION ON THE FACE HEREOF, OR AS OTHERWISE SET FORTH HEREIN. NO OTHER WARRANTIES, EXPRESSED OR IMPLIED, BY OPERATION OF LAW OR OTHERWISE ARE MADE, INCLUDING BUT NOT LIMITED TO, MERCHANTABILITY OR FITNESS FOR A PARTICULAR PURPOSE. UNDER NO CIRCUMSTANCES SHALL FLOORING MANUFACTURER BE LIABLE FOR ANY LOSS OR DAMAGE ARISING FROM THE PURCHASE, USE, OR INABILITY TO USE THIS PRODUCT, FOR ANY SPECIAL, INDIRECT, INCIDENTAL OR CONSEQUENTIAL DAMAGES. SOME STATES DO NOT ALLOW LIMITATIONS ON HOW LONG AN IMPLIED WARRANTY LASTS, OR THE EXCLUSION OR LIMITATION OF INCIDENTAL OR CONSEQUENTIAL DAMAGES, SO THE ABOVE LIMITATIONS MAY NOT APPLY TO YOU. THIS WARRANTY GIVES YOU SPECIFIC LEGAL RIGHTS. YOU MAY ALSO HAVE OTHER RIGHTS WHICH VARY FROM STATE TO STATE. YOUR RIGHTS AND THE LIMITATIONS DESCRIBED ABOVE VARY FROM STATE TO STATE. THUS, IT IS IMPORTANT TO RETAIN THIS WARRANTY INFORMATION. NO INSTALLER, RETAILER, DISTRIBUTOR, AGENT, OR EMPLOYEE OF FLOORING MANUFACTURER HAS THE AUTHORITY TO INCREASE OR ALTER THE OBLIGATIONS OR LIMITATIONS OF THIS WARRANTY.

HANDLING OF CLAIMS

UNDER THIS WARRANTY

Claims must be filed within the coverage period, and information verifying the date of purchase may be required. Flooring manufacturer reserves the right to have a designated flooring manufacturer representative inspect the floors and remove samples for technical analysis.

If you need to file a claim under this warranty, first contact your flooring manufacturer retailer. If for some reason, your retailer is unable to satisfy your claim, you may contact us at: Flooring Manufacturer, Claims Department, P.O. Box 3549 Johnson City, Tennessee 37602.

Any and all disputes arising out of the purchase of flooring manufacturer products or this warranty shall be subject to mandatory and binding arbitration in Johnson City, Tennessee, pursuant to the rules of the American Arbitration Association. Any trials by jury are expressly waived.

FLOORING MANUFACTURER SOLID AND ENGINEERED PRODUCT FEATURES

PRODUCT	PAD & RECOAT	SAND & REFINISH *	INSTALL OVER RADIANT HEAT	WHERE TO INSTALL
SOLID	YES	YES	NO	ON GRADE ABOVE GRADE
ENGINEERED	YES	YES	YES (OAK ONLY)	ON GRADE ABOVE GRADE BELOW GRADE

*If your floor is sanded down to the bare wood and a new finish is applied, all finish warranties must be assumed by the finish manufacturer.

Engineered LOC

Floating Installation Instructions

FLOATING INSTRUCTIONS

ATTENTION

Inspect **ALL** materials carefully **BEFORE** installation. Warranties **DO NOT** cover materials with visible defects once they are installed.

It is the responsibility of the installer/owner to determine if the job site subfloor and job site conditions are environmentally and structurally acceptable for wood floor installation. Flooring manufacturer declines any responsibility for wood floor failure resulting from or connected with subfloor, subsurface, job site damage or deficiencies after hardwood flooring has been installed.

CHECKLIST

You find additional information to each section further below:

- Store the packages in the future room climate and open package after package when you install.
- This floor will be floating installed, i.e. always keep a minimum 3/8" distance to all walls and vertical obstructions.
- Check your subfloor, it must be dry (measure always!), clean, firm, and flat.
- Measure the room, decide installation direction. Note the limitations as per below – due to natural behavior of wood!
- Radiant Heat (OAK Only) – see special advices and requirements – follow the instructions from the system supplier!
- Check your floor continuously during the installation. Defective boards that are installed are not covered by warranty.
- Keep room climate 35-55% RH at 64-78°F, before, during, and after install.

GENERAL INFORMATION

Preparation of subfloor

Subfloor irregularities and undulation may cause any wood flooring installation to develop hollow spots between the flooring and subfloor. These hollow spots are NOT the result of any wood floor manufacturing defect and are NOT covered by the manufacturer warranty.

Note: Normal expansion space around the room should be the same distance as the thickness of the hardwood flooring or a minimum of 3/8".

Thoroughly clean subfloor:

Remove paint, wax, oil, plaster, "sheetrock mud" and other foreign materials, as well as obvious surface irregularities. #3-1/2 grit open coat paper may need to be used to grind a concrete subfloor. This will loosen any dirt, loose concrete or contaminates. Sweep or vacuum thoroughly. All previous or existing glues or adhesives must be removed before installing new hardwood floor. Concrete subfloors must be clean, flat, sound and sufficient compression strength (3000 lbs. P.S.I.) being sure that the surface is NOT slick.

Sections not flat due to waviness, trowel marks, etc. are to be flattened by grinding or the use of leveling compound. Especially along the walls, the subfloor flatness must be checked and if necessary improved. Flatten to 3/16" in 10' radius. In addition to cement subfloors, these wood flooring products can be installed over dry, flat subfloors such as plywood.

Time at which to install hardwood flooring: Lay only after sheetrock and tile work are thoroughly dried and all but the final woodwork and trim have been completed. The building interior should have been dried and seasoned and a comfortable working temperature (at least 60° F) and a relative humidity of 35 – 55% should exist during installation. If subfloor is concrete, check for dryness see below. If moisture is present, do not lay. All concrete subfloors on or below grade need to be tested.

Concrete subfloor Moisture Testing:

Electrical Impedance Test and Electrical Resistance Test (Concrete Moisture Meters) Follow Moisture Meter MFG Guidelines. If Meter shows possibility of excess moisture further testing is required. Calcium Chloride Test. See below.

Relative Humidity Test (Standard test method for determining relative humidity on concrete floor slabs using Situ Probes. If test shows over 75% vapor retarder must be used or wait for further curing.

Calcium Chloride Test ASTM F-1869 Readings over 3 lbs and up to 7 lbs vapor retarder needed.

As part of your subfloor preparation remove any existing base, shoe mold or doorway thresholds. These items can be replaced after installation, but should be replaced in such a way as to allow at least 3/8" room for expansion around the perimeter of the room. All door casings should be notched out or undercut to allow 3/8" room for expansion and to avoid difficult scribe cuts. This is easily done by placing a piece of the engineered product on the subfloor as a height guide for your handsaw or jamb saw.

The use of flooring putty to cover small cracks or face nail holes should be considered normal in hardwood flooring installation.

New wood type subfloors should also be checked for moisture using a moisture meter. In general, wood or plywood subfloors should not exceed 14% moisture content and no more than 4% MC difference between wood flooring and subfloor. Check with your local distributor for your geographical variances. If the plywood is used as an overlay over the existing subfloor, the thickness of the overlay material must be such as to yield a total 3/4" subfloor thickness.

Floor Heating – OAK SPECIES ONLY

Installation over subfloor heating – some important issues.
Max allowed temperature on top of the wood is 75°F.

Important: Follow the heating regulation recommendations given by the system supplier.

Please note two-in-one foam underlay must be placed on top of the sub-floor either made of cement screed/concrete, etc. or also over wood!

INSTALLATION PREPARATIONS

General

Measure the area to be installed and define the installation direction.

It is recommended to install the length direction of the planks parallel to the main light direction. (See figures on page 2.)

Floating Installation

Your floor is made to be installed floating. Leave an open expansion gap around the whole perimeter (use wedges), i.e. also at pipes, stairs, columns, door frames and thresholds.

The floor must be able to move free – do not connect or install tight to any construction part. Rooms with off square areas like for example L, T, U shapes, separate the areas with an expansion joint and especially always in door openings.

Contact your distributor for further information.

AFTER THE INSTALLATION

Room climate – humidifier or de-humidifier needed?

At all times, before, during and after installation, the recommended room relative humidity (RH) of 35-55% and temperature of 68-78°F should be kept. If necessary install a humidifier/dehumidifier to ensure the best climate for yourself, furniture, and your floor.

Installing the floor:

- The floor should be installed from several cartons at the same time to ensure color and shade mix.
- End joints should never be closer than 9 inches or half the distance of the plank from each other. (See figure 8.)
- Install base and molding after floor installation.

Floor protection furniture, entrances

Stick felt pads to chair and other pieces of furniture legs. Place doormats at out door entrances.

- Do not wet mop floors.
- Do not use tape on finish.
- Do not use automated cleaning machines.

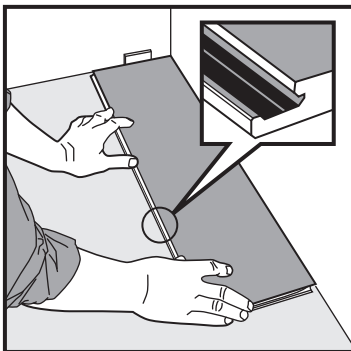

Fig 1.
First plank, first row. Start in a left-hand corner of the room with the locking strip (groove) facing the room. Remember to leave a gap between the wall (left) and the board. It is practical to adjust the gap between the long sides and the wall later, when three rows have been installed.

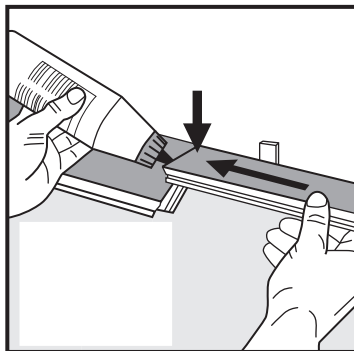

Fig 2.
Joining length cut panels. First row(s). Glue the joint with white glue, put a weight over until the glue has hardened.

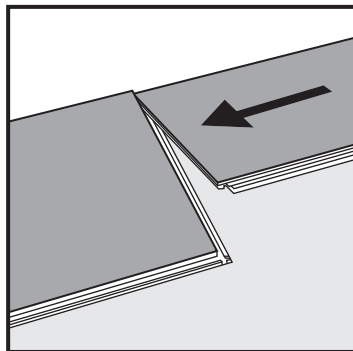

Fig 3.
Second plank, first row
Place next floorboard tight to the short end of the first one in the corner.

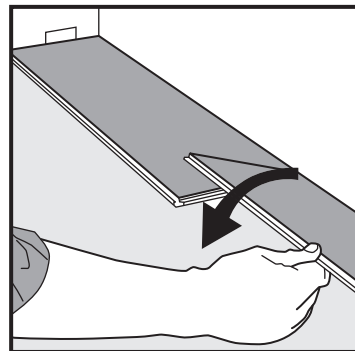

Fig 4.
Then fold down with a single action movement. Make sure the long sides of the planks make a straight line. Complete the first row in the same way.

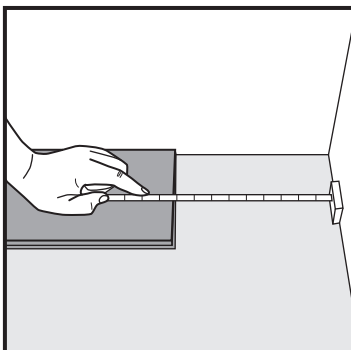

Fig 5.
At the end of the first row, put a distance of 3/8", to the wall and measure the length of the last plank to fit.

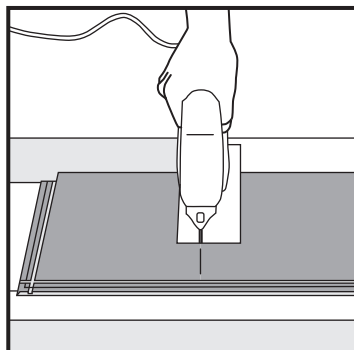

Fig 6.
Cut with a saw – hardwood turned down or with a hand saw with the hardwood visible.

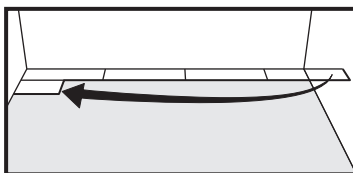

Fig 7.
Second row.

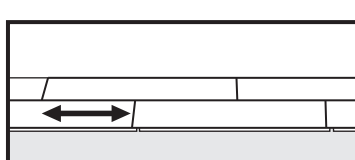

Fig 8.
General. Minimum distance between short ends of planks in parallel rows shall not be less than 9" or half the distance of the plank.

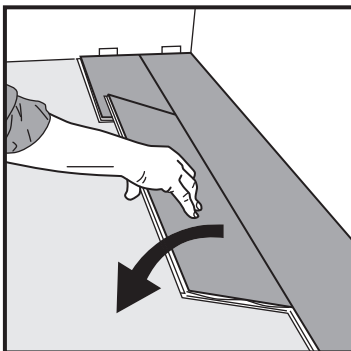

Fig 9.
Second plank second row. Place the floorboard tight to the short end of the previous panel and fold down in a single action movement.

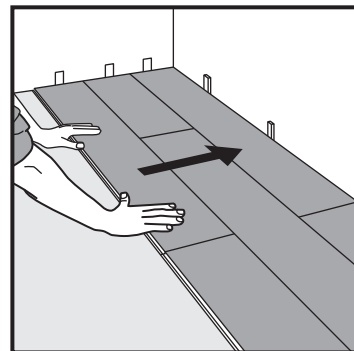

Fig 10.
After 2-3 rows. Adjust the distance to the front wall by placing distances $\approx 3/8"$.

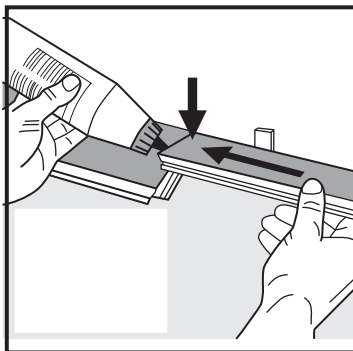

Fig 11.
Joining length cut panels. First/last row(s). Glue the joint with white glue, put a weight over until the glue has hardened.



Fig 12.
Horizontal installation (where angling is not possible). Cut off the locking element by using for example a chisel.

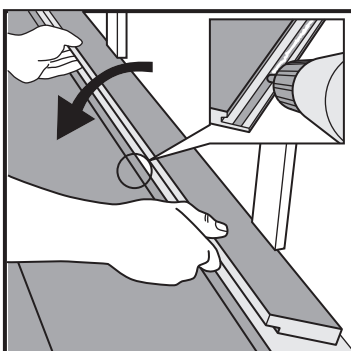

Fig 13.
Put white glue along the adjusted profile and press the panels horizontally together.

