

GREX® P650LXE

2" 23 Gauge Headless Pinner

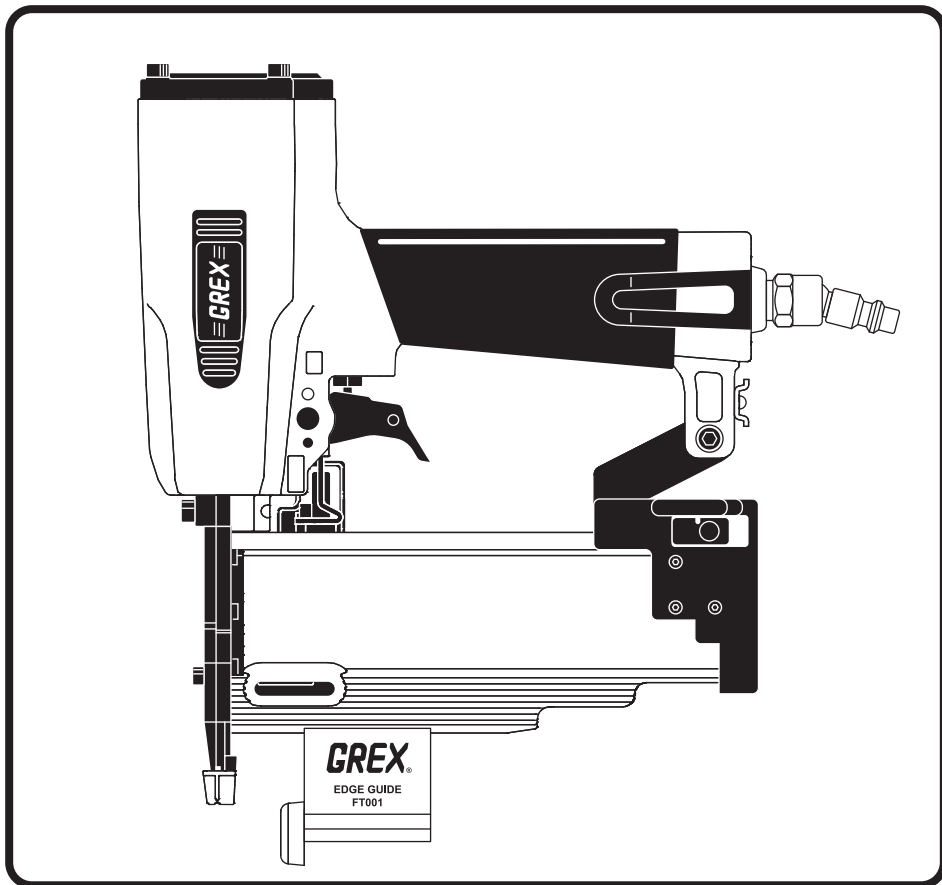

CAUTION: Before attempting to use or service this tool, carefully read and understand all rules and instructions for safe operation.



NOTE: This manual includes safety warnings, operation instructions, and tips on the maintenance and inspection of this tool.

Congratulations on your purchase of a **GreX 23 Gauge Headless Pinner**; a high performance precision tool that has become an industry standard in driving the smallest nails. Precision machining and carefully selected materials are employed in the manufacturing process of each tool to ensure consistent high performance and adherence to GreX's high quality standards. Because of the fine and narrow tip of the driver, to maintain your GreX 23 Gauge Headless Pinner at its peak performance, proper care and attention to its operation must be observed. Please take the time to read and understand this owner's manual so you can get the most out of your pinner and ensure long-lasting, reliable operation. **Thank you for choosing GreX.**

TABLE OF CONTENTS

1.0 Safety Instructions	1
1.1 Registering Your Tool	1
1.2 Employer's Responsibilities	1
1.3 Safety Instructions	1
2.0 Compressed Air System	4
3.0 Tool Specifications	5
3.1 Kit Contents	5
3.2 Suggested Applications	5
3.3 Technical Specifications	5
3.4 Tool Anatomy	6
4.0 Fastener Compatibility	7
5.0 Tool Operation	8
5.1 Pre-Operation Checklist	8
5.2 Testing the Tool	9
5.3 Adjusting Air Pressure	11
5.4 Loading Fasteners	12
5.5 Mode of Operation	13
5.6 Auto Lock-out with One-Touch Over-Ride	14
5.7 Edge Guide	15
5.8 No-Mar Rubber Tip	16
5.9 Adjustable Belt Hook	17
6.0 Maintenance and Inspection	18
6.1 Clearing Jammed Fasteners	18
6.2 Clean and Inspect Daily	19
6.3 Lubrication	19
6.4 Storage	19
6.5 Cold Weather Care	20
6.6 Troubleshooting	21

1.1 REGISTERING YOUR TOOL

IMPORTANT: Please fill out and return the enclosed Product Registration Card or register online at www.grexusa.com within the next ten days. By registering your tool, we will be able to acknowledge the limited warranty offered for your GreX product.

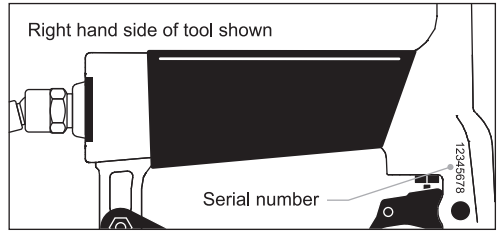

1.2 EMPLOYER'S RESPONSIBILITIES

1. Keep this manual available for use by all people assigned to use this tool.
2. Employer must enforce compliance with safety warnings & all instructions contained in this manual.
3. For personal safety & proper operation of this tool, read and follow all of these instructions carefully.
4. Ensure that tools are used only when operators & others in work area are wearing safety protection.
5. Enforce the use of safety protection, especially safety eyewear, by operators and others in area.
6. Keep tools in safe working order and maintain them properly.
7. Ensure that tools that require repair are not further used before repair.



IMPORTANT: Save this manual and review it frequently for continuing safe operation.

1.3 SAFETY INSTRUCTIONS



WARNING: Do not attempt to operate this tool unless you have read and fully understood all instructions and safety precautions contained in this manual. Failure to comply can result in serious injury to yourself and bystanders.



1. Always wear protective equipment.

To prevent eye injuries, safety glasses should be worn by the operator and others in the work area that conforms to requirements of ANSI Z87.1 & provides both frontal & side protection. Always wear other personal protective equipment such as hearing protection & hard hats.



2. Use only clean, dry, regulated compressed air.

Do not operate the tool on oxygen, carbon dioxide, combustible gases or any other bottled gases; the tool will explode and cause serious injury.



3. Operate within the proper air pressure range.

Do not exceed the maximum recommended air pressure of 110 psi (7.6 bar) and never connect the tool to air pressure which potentially exceeds 200 psi (13.7 bar) as the tool can burst.

1.3 SAFETY INSTRUCTIONS (continued)

4. Use the correct type of air hose.

Air hose must have a minimum working pressure rating of 150 psi (10.4 bar) or 150% of the maximum pressure produced in the system, whichever is higher.

5. Do not operate tool near flammable substances.

Volatile fumes from these substances can be drawn into the compressor and compressed together with the air, causing risk of explosion.

6. Never point tool toward yourself or anyone else.

Always assume tool contains fasteners. Keep tool pointed away from yourself and others at all times. Never engage in horseplay with your tool. Respect your tool as a working implement.

7. Keep visitors away.

Do not let visitors handle the tool. All visitors should be kept safely away from the work area.

8. Inspect tool condition and maintain with care.

Make sure screws and caps are securely tightened at all times. Never use tool if parts are missing or damaged, leaks air, or needs repair. Keep tool clean and lubricated for better and safer performance.

9. Check safety before use.

Make sure the safety operates properly before use. Never use the tool if the safety is not operating properly, otherwise the tool could drive a fastener unexpectedly. Never tamper with or remove the safety, otherwise the safety becomes inoperable.

10. Be careful of double fire due to recoil.

If the safety is unintentionally allowed to re-contact the work surface following recoil, an unwanted fastener will be driven accidentally. Read and understand section titled "**Mode of Operation**" to avoid this undesirable double fire.

11. Never drive nails from both sides of wall at the same time.

Nails can potentially be driven through the wall and hit a person on the opposite side.

12. Check for live electrical wires.

Avoid the risk of severe electrical shock by checking for live electrical wires that are hidden by walls, floors or ceilings. Turn off the breaker switch to ensure there are no live wires.

13. Drive fasteners carefully.

Never drive fasteners into materials too hard to penetrate. Do not drive fasteners into thin boards or near corners and edges of work piece; they may be driven through or away from work piece. Do not drive fasteners on top of other fasteners or with tool at too steep an angle; the fastener can ricochet and cause personal injury or injury to bystanders.

14. Never modify or alter the tool.

Doing so may cause it to malfunction and personal injuries may result.

1.3 SAFETY INSTRUCTIONS (continued)

15. Load fasteners carefully.

Always disconnect air supply from tool before loading fasteners. Have tool pointed downwards and away from yourself or any bystanders at all times.

16. Use only relieving couplers on tool and air supply hose.

The tool and air supply hose must have a hose coupling such that all pressure is removed from the tool when the coupling is disconnected. If not, the tool can remain charged with air after disconnecting and be able to drive a fastener even after being disconnected.

17. Only connect air hose when actively operating tool.

Disconnect tool from air before performing any tool maintenance, clearing jammed fasteners, leaving work area, moving tool to another location, or handing the tool to another person.

18. Empty fasteners from magazine when tool is not in use.

Remove all fasteners from tool before connecting air hose, doing tool maintenance, or when operation has been completed or suspended.

19. Dress properly.

Be sure not to wear clothing or jewelry that may be caught in moving parts. Rubber gloves and non-slip footwear are recommended when working outdoors. Wear protective hair covering to contain long hair.

20. Handle tool carefully and correctly.

Operate tool according to this manual. Never allow tool to be operated by children, individuals unfamiliar with its operation or unauthorized personnel. Do not drop tool or strike the tool against hard surfaces; and do not scratch or engrave signs on the tool. Doing so may result in cracks on the tool surface, which can be extremely dangerous because of the high pressures. Never carry tool by hose.

21. Keep work area clean.

Cluttered areas invite injuries. Clear work areas free of unnecessary tools, debris, furniture, etc.

22. Stay alert.

Watch what you are doing. Use common sense. Do not operate tool when tired, or under the influence of alcohol, drugs, or medication that causes drowsiness.

23. Do not overreach.

Keep proper footing and balance at all times.

24. Keep idle tool in storage.

When not in use, tool should be kept in dry, and high or locked-up places - out of reach of children.

25. Never use tool for application other than those specified in this manual.

Using tool for applications other than those intended for may harm the tool, cause personal injury to operator and injury to bystanders.

26. Use only parts, accessories or fasteners supplied or recommended by GREX.

Unauthorized parts, accessories, or fasteners may void your warranty and can lead to malfunction and resulting injuries. Do not modify the tool without written approval from GREX.

2.0 COMPRESSED AIR SYSTEM



NOTE: The following illustration shows the ideal mode of connection to the compressed air system which will increase the efficiency and useful life of the tool.

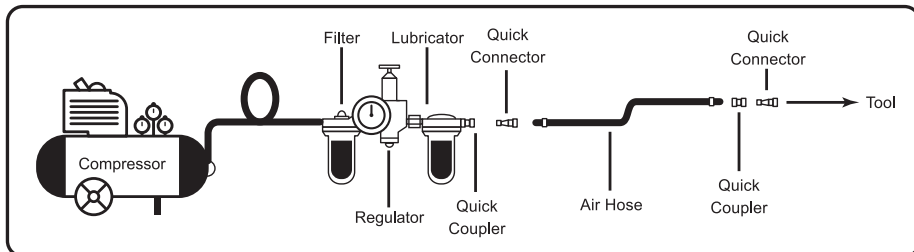

1. Power Source

- Use clean, dry, regulated compressed air as a power source for the tool.
- Air compressors used to supply air to this tool must comply with the requirements of the latest version of ANSI Standard B 19.3 "Safety Standard For Compressors For Process Industries".
- Refer to your compressor's owner's manual for proper safety instructions and operation.
- Moisture or oil in the air compressor may accelerate wear and corrosion in the tool.
- Never use oxygen, combustible gases or any other bottled gases.

2. Filter-Regulator-Lubricator

- Use a regulator with a pressure range of 0-120 psi (0-8.3 bar).
- Filter-regulator-lubricator units supply an optimum condition for the tool and extend tool life.
- These units should always be used:
 - » Filter The filter removes moisture and dirt mixed in the compressed air. Drain daily unless fitted with an automatic drain. Keep the filter clean by regular maintenance.
 - » Regulator The regulator controls the operating pressure for safe operation of the tool. Inspect the regulator before operation to be sure it operates properly.
 - » Lubricator The lubricator supplies an oil mist to the tool. Inspect the lubricator before operation to be sure the supply of lubricant is adequate.



NOTE: If manual lubrication is used, then a lubricator is not necessary. See "Lubrication" under the "Maintenance and Inspection" Section on page 17.

3. Air Hose

Air hose must have a minimum working pressure rating of 150 psi (10.4 bar, 10.6 kgf/cm²) or 150% of the maximum pressure produced in the system, whichever is higher.

4. Hose Coupling

Install a 1/4" NPT male plug at the air inlet of the tool. A female coupler must be installed on the air hose. The hose coupling (male-female coupler) must remove all pressure from the tool when disconnected. Never use a non-relieving coupler on the tool. Doing so will leave the tool charged with air after disconnecting and be able to drive a fastener even after being disconnected.

3.1 KIT CONTENTS

- **GreX 2" 23 Gauge Headless Pinner with Edge Guide**
- **Tool Carrying Case**
- **Owner's Manual**
with Parts Diagram and Product Warranty Card
- **Safety Goggle**
- **Bottle of Tool Oil**
After first use, to avoid oil from leaking, store the bottle upright in a safe place.
- **Hex Keys**
2.0mm, 2.5mm, & 4.0mm Hex Keys
3.0mm Hex Key (stored on tool)



3.2 SUGGESTED APPLICATIONS

Crown molding, Light wood assembly, Finish and trim work, Molding and decorative trim, Cabinet assembly, Mirror and picture frame assembly, Paneling, External softwood trim, Glazing strips, Craft work, Window beading, Display and sign work.

3.3 TECHNICAL SPECIFICATIONS

Model No.	P650LXE
Dimensions	9.75"L x 8.25"H x 2"W (24.8 x 21 x 5.1 cm)
Weight	3.25 lbs. (1.5 kgs.)
Operating Pressure *	60 ~ 110 psi (4 ~ 7.6 bars)
Fastener Type	23 gauge headless pins
Fastener Range †	3/8" ~ 2" (12mm ~ 50mm), 13 Total Lengths
Fastener Capacity	1 strip (approx. 100 nails)
Air Inlet	1/4" (6mm) NPT male plug

* Refer to section titled "Adjusting Air Pressure" on page 11 for optimal operating air pressure settings.

† Refer to section titled "Fastener Compatibility" on page 7 for details.

3.4 TOOL ANATOMY

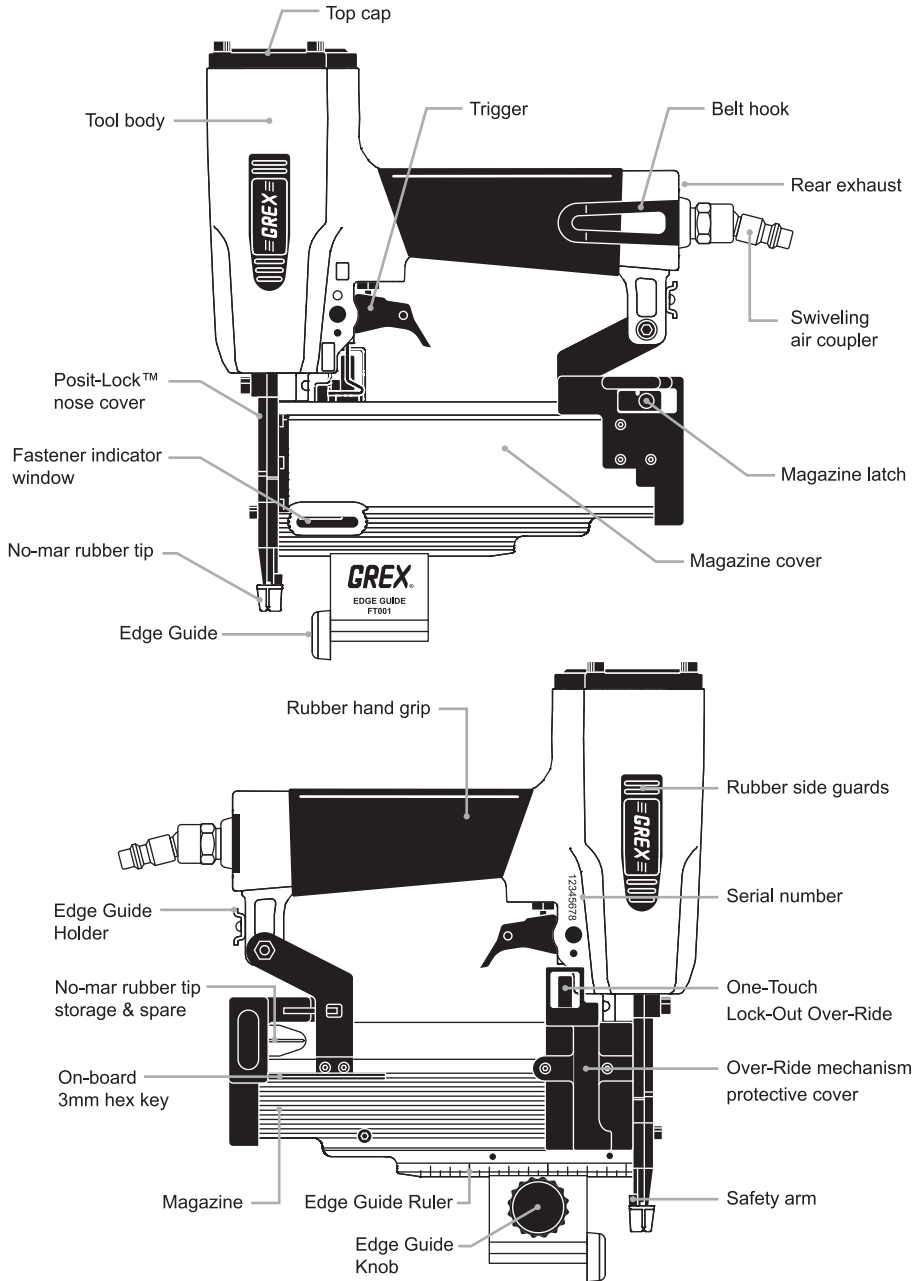

4.0 FASTENER COMPATIBILITY



WARNING

ONLY use fasteners designated as **23 GAUGE HEADLESS PINS**.

Do not use 23 gauge pins that have a brad or slight headed brad, doing so may cause jamming and damage to your tool.

DO NOT use 1-1/4" (32mm) length pins. Doing so may result in jamming, because the magazine is not designed to accommodate this pin length.

Although any brand of **23 GAUGE HEADLESS PINS** are compatible with your GreX Pinner, GreX pins are highly recommended due to the optimal tensile strength of the steel used. Using poor quality pins will cause jamming and damage to your tool.





Use the following chart to identify the product number for the types and different lengths of 23 Gauge Headless Pins available from GreX.

13 Total Lengths Fastener Lengths		Galvanized & Coated 10,000 pcs. per box	Galvanized & Coated 2,500 pcs. per pack	Stainless Steel 5,000 pcs. per box
3/8"	10mm	P6/10L	P6/10-2.5	P6/10-ST
1/2"	12mm	P6/12L	P6/12-2.5	P6/12-ST
5/8"	15mm	P6/15L	P6/15-2.5	P6/15-ST
3/4"	20mm	P6/20L	P6/20-2.5	P6/20-ST
7/8"	22mm	P6/22L	P6/22-2.5	
1"	25mm	P6/25L	P6/25-2.5	P6/25-ST
1-1/8"	28mm	P6/28L	P6/28-2.5	
1-3/16"	30mm	P6/30L	P6/30-2.5	P6/30-ST
1-3/8"	35mm	P6/35L	P6/35-2.5	P6/35-ST
1-1/2"	38mm	P6/38L	P6/38-2.5	P6/38-ST
1-9/16"	40mm	P6/40L	P6/40-2.5	
1-3/4"	45mm	P6/45L	P6/45-2.5	P6/45-ST
2"	50mm	P6/50L	P6/50-2.5	P6/50-ST
Multi-Pack Pins			Galvanized & Coated	Stainless Steel
3,000 pcs. total per pack; 500 pcs. each length 3/8" (10mm), 1/2" (12mm), 5/8" (20mm), 3/4" (20mm), 1" (25mm), 1-3/8" (35mm)			P6/MP-3 6 different lengths 3/8" ~ 1-3/8"	P6/MP-ST3 6 different lengths 3/8" ~ 1-3/8"
2,500 pcs. total per pack; 500 pcs. each length 1-3/16" (30mm), 1-3/8" (35mm), 1-1/2" (38mm), 1-3/4" (45mm), 2" (50mm)			P6/MP-L 5 different lengths 1-3/16" ~ 2"	P6/MP-STL 5 different lengths 1-3/16" ~ 2"

5.1 PRE-OPERATION CHECKLIST

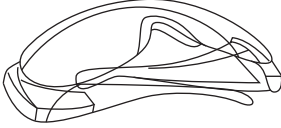

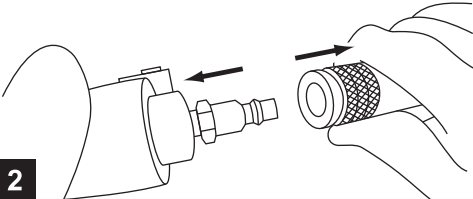
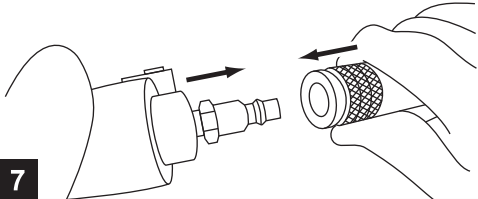
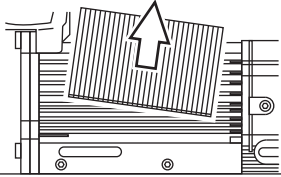
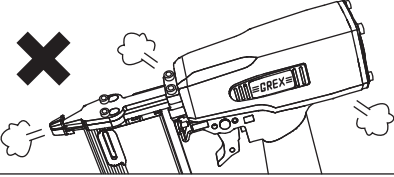
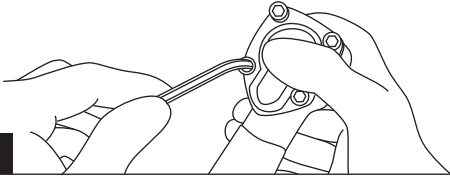
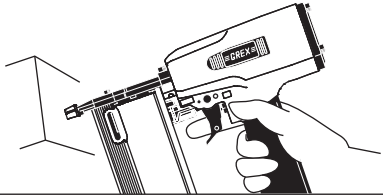
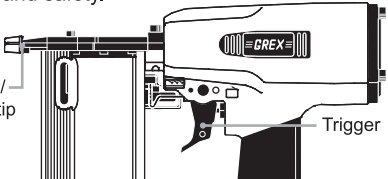
WARNING: Read section titled "Safety Instructions" on page 1 before operating tool.

<p>Wear safety glasses or goggles.</p>  <p>1</p>	<p>Adjust the air supply to 70 psi.</p>  <p>6</p>
<p>Disconnect the air supply.</p>  <p>2</p>	<p>Connect the air supply to the tool.</p>  <p>7</p>
<p>Remove all fasteners from tool.</p>  <p>3</p>	<p>Check for any air leakage. The tool must not leak air to operate properly.</p>  <p>8</p>
<p>Inspect all screw tightness.</p>  <p>4</p>	<p>Follow steps in section "Testing the Tool".</p>  <p>9</p>
<p>Check for smooth and proper operation of the trigger and safety.</p>  <p>5</p>	<p>Adjust operating air pressure by following steps in section "Adjusting Air Pressure".</p>  <p>10</p>

5.2 TESTING THE TOOL



WARNING

Read section titled "Safety Instructions" on page 1 before operating tool.

Never use tool unless safety is operating properly.

If abnormal operation occurs, contact Grex or an authorized service center immediately.

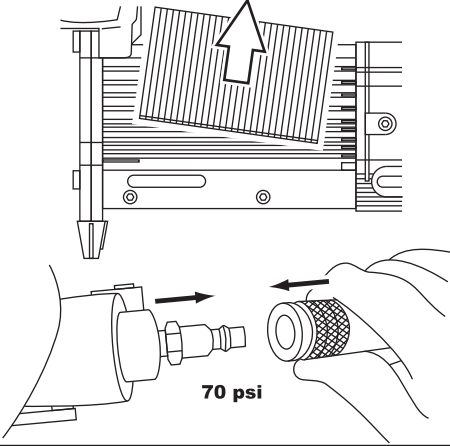
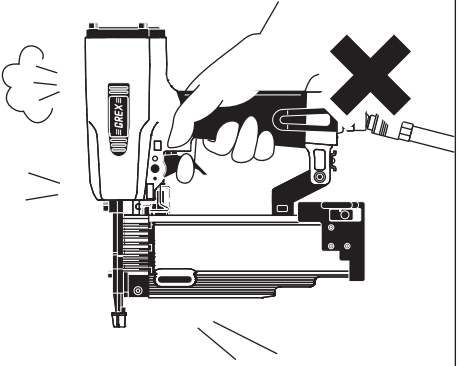
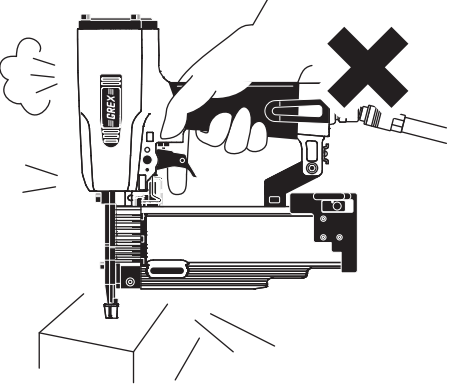
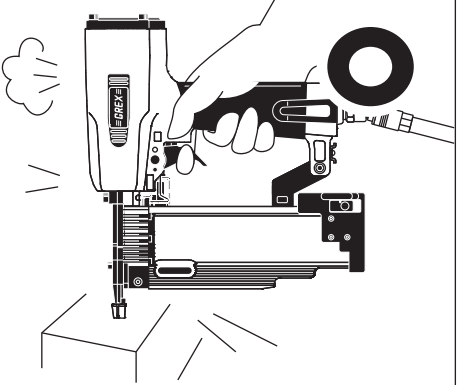
<p>1 With fasteners removed, set air supply to 70 psi and connect air hose. Keep the magazine slightly opened.</p> 	<p>3 Lift tool away from work piece. Hold tool pointed downward. Pull and hold trigger for 3 seconds. The tool must NOT drive. Release the trigger.</p> 
<p>2 Remove finger from trigger. Depress safety against work piece. The tool must NOT drive.</p> 	<p>4 Depress safety against work piece. Pull on trigger and hold. The tool MUST drive.</p> 

Instructions continued on following page.

5.2 TESTING THE TOOL (continued)



WARNING

Read section titled "Safety Instructions" on page 1 before operating tool.

Never use tool unless safety is operating properly.

If abnormal operation occurs, contact GreX or an authorized service center immediately.

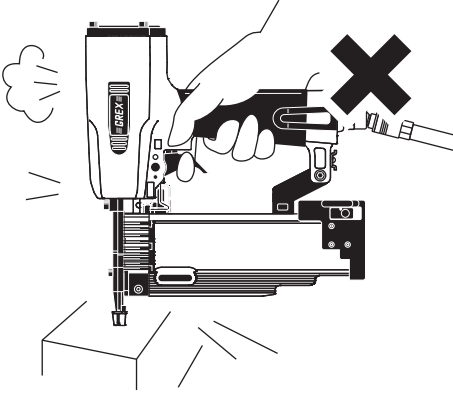
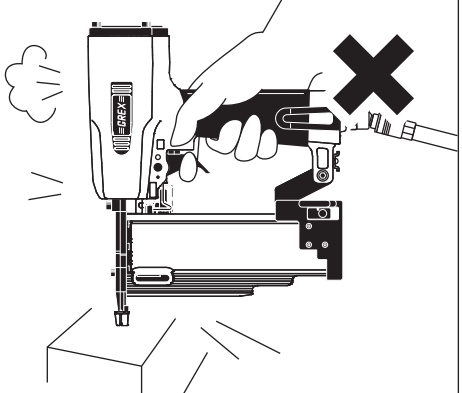
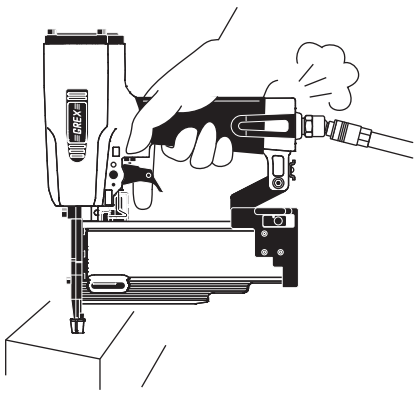
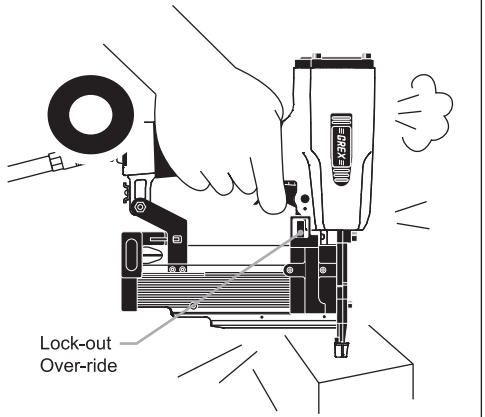
<p>5 While keeping trigger held. Lift tool off work piece. Again depress safety against work piece. The tool must NOT drive.</p> 	<p>7 Depress safety against work piece. Pull and release the trigger. The tool must NOT drive. Lift tool off work piece.</p> 
<p>6 Release trigger. The tool MUST return to ready mode. Lift tool off work piece. Close the magazine cover.</p> 	<p>8 Press and release the lock-out over-ride. Depress safety against work piece. Pull and release the trigger. The tool MUST drive.</p> 

If no abnormal operation is observed, you may load fasteners into the tool.

5.3 ADJUSTING AIR PRESSURE



WARNING

Read section titled "Safety Instructions" on page 1 before operating tool.

Insufficient operating air pressures will damage your tool. Your GreX Pinner is a precision tool capable of driving very fine 23 gauge pins. Optimal operating air pressures are required to minimize wear and prevent damage.

- Adjust the air pressure within the recommended operating pressure range of 60 - 110 psi (4.0 - 7.6 bar) according to the length of nails and hardness of the work piece.
- The correct air pressure is the lowest pressure which will set the nails at the required depth.
- Before driving fasteners into the work piece, test drive fasteners on similar materials to be used in the actual application to determine the optimal air pressure.
- Insufficient operating air pressures will prevent your tool from setting pins all the way into your work piece and also cause the driver to drive pins in at insufficient speeds. This forces the driver to "push" rather than quickly "punch" pins into the work piece resulting in excessive stress on the driver tip, which will lead to increased wear and damage.
- Excessive operating air pressures may set nails too deep into your work piece, damage the work piece, over stress the tool and increase driver wear.
- Use the guide below for a starting point to adjusting the operating air pressure for your tool. Note that driving pins into harder woods will generally increase driver wear.

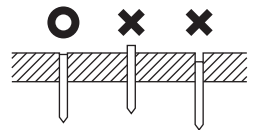

P650LX

- Begin with the recommended operating air pressure of **90 psi**.
- For pins **LONGER** than 1-3/8", maintain the operating air pressure at **90 psi** or more.
- For pins **SHORTER** than 1-3/8", adjust operating air pressure to **80 psi**
 - In hard woods, maintain the operating air pressure at **80 psi** or more.
 - In soft woods, the air pressure can be lowered to prevent setting pins too deep.



WARNING

This tool is **EXTRA POWERFUL**. Be **EXTRA CAREFUL**. This tool is designed with an extra powerful motor to accommodate smaller air compressors that have difficulty maintaining higher air pressures. Operating the tool at excessive air pressures will damage the tool.

DO NOT EXCEED 100 psi unless the combination of wood hardness and pin length used makes it necessary. For example, driving 2" long pins into extremely hard exotic woods.

When setting the operating air pressure for your tool, make sure your air compressor is capable of maintaining the recommended air pressures outlined above. Even if you regulate the air to a certain pressure, the actual line pressure may be lower due to the lower kick-in pressure set on your compressor. To constantly maintain sufficient air pressure for your tool, it may be necessary to adjust your compressor's kick-in pressure. Refer to your compressor's owner's manual for more information on your compressor's settings.

5.4 LOADING FASTENERS



WARNING

Read section titled "Safety Instructions" on page 1 before operating tool.

NEVER load different lengths and/or types of fasteners at the same time. Doing so, could result in jamming and/or damage to your tool.

Before loading fasteners, **ALWAYS** remove existing fasteners and/or fastener strip fragments in the nose area that may have been left over from the previous work session.

Your Grex 23 Ga. Headless Pinner is designed with the patented "adjust-free magazine". Adjustments are unnecessary when using different fastener lengths. Follow the fastener loading instructions below carefully. Improper loading may cause jamming and/or damage to your tool.

<p>Disconnect your tool from the air supply.</p> <p>1</p>	<p>Slide fasteners forward all the way into the tool nose.</p> <p>4</p>
<p>Push down on magazine latch and gently pull magazine cover back as far as possible.</p> <p>2</p>	<p>5</p>
<p>Insert a strip of fasteners into the magazine. Insert pins all the way down</p> <p>Arrows on pins must point down</p> <p>3</p>	<p>Push magazine cover forward until the magazine latch catches securely.</p> <p>6</p>



WARNING

When loading fasteners into the tool, do not depress the safety and/or the trigger.

Keep yourself as well as other persons away from the nose to avoid possible injury.

5.5 MODE OF OPERATION



WARNING

Read section titled "Safety Instructions" on page 1 before operating tool.

Before operating tool, make sure you have gone through the pre-operation checklist with no problems, adjusted the operating pressure correctly and loaded the fasteners correctly.

This tool is designed to only operate in **SEQUENTIAL FIRE MODE**. The tool will not operate unless the safety is first depressed on to the work piece before the trigger is pulled. After driving a fastener, it will not be possible to drive another fastener until the trigger is released and pulled again.



WARNING

Be careful of double firing due to recoil.

If the safety is unintentionally allowed to re-contact the work surface following recoil, an unwanted fastener will be driven accidentally. To avoid this undesirable double firing, pull and release the trigger rapidly and firmly each time.

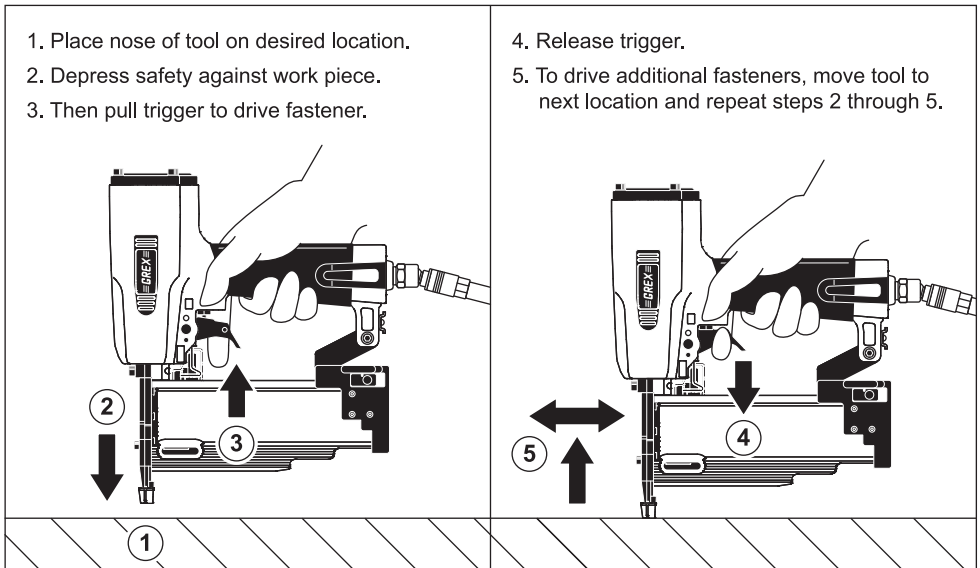

WARNING

DO NOT drive pins into metal. Doing so will damage the driver and may cause personal injury to yourself and/or bystanders. Make sure there is no hidden metal in the workpiece (such as screws and nails) that your pinner can potentially drive pins into.

DO NOT move or drag the nose of your tool across the workpiece surface. Doing so may damage and possibly break the tip of your driver.

5.6 AUTO LOCK-OUT FEATURE with ONE-TOUCH OVER-RIDE

When the tool magazine has approximately **10 or less fasteners remaining**, the auto lock-out mechanism will activate and prevent the tool from being fired. This feature offers the following benefits:

1. prevents empty holes in your work piece
2. minimizes tool damage and wear from empty firing
3. alerts operator to reload before the tool is empty

One-Touch Over-ride

Once the lock-out mechanism activates, the tool will **NOT** operate unless either more fasteners are loaded or the lock-out is over-riden by pressing and releasing once on the Over-Ride lever. The auto lock-out will permanently deactivate and allow all remaining fasteners to be driven. The next time the magazine cover is opened the auto lock-out mechanism will reset and will again activate when there are approximately 10 or less fasteners remaining in the tool magazine .

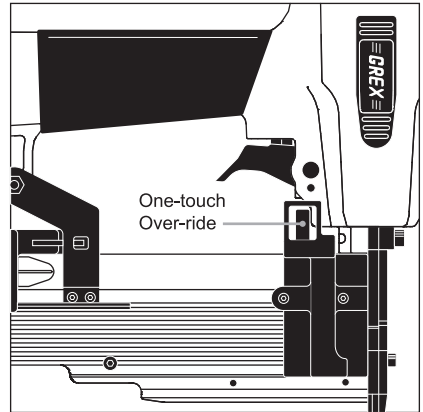

IMPORTANT After the lock-out is over-riden, there are only about 10 pins remaining and the lock-out will not re-activate unless the magazine cover is opened. If you choose not to reload more pins, keep a loose count when driving these last remaining pins to avoid empty firing the tool.

Removing Locked-Out Fasteners



Before loading fasteners, **ALWAYS** remove existing fasteners and/or fastener strip fragments in the nose area that may have been left over from the previous work session. Loading fasteners of different lengths may cause jamming and/or damage to the driver.

Activated lock-out mechanism may leave remaining fasteners in the nose hidden from the operator's view. These fasteners can be accessed by:

1. Disconnecting the tool from the air supply and opening the magazine cover.
 - Tilt tool back to allow remaining fasteners to fall back from the nose. Be sure to remove all fasteners.
2. If fasteners still remain, follow the steps in the "Clearing Jammed Fasteners" section on page 16.

5.7 EDGE GUIDE

Work up to two times faster and with more precision with the GreX Edge Guide. This patent pending design lets you easily drive nails at a consistent distance from a referenced edge. It also helps drastically minimize nails from blowing out the side of the workpiece and enables you to drive nails in difficult to see situations. The Edge Guide easily adjusts to distances up to about 3" from a reference edge.

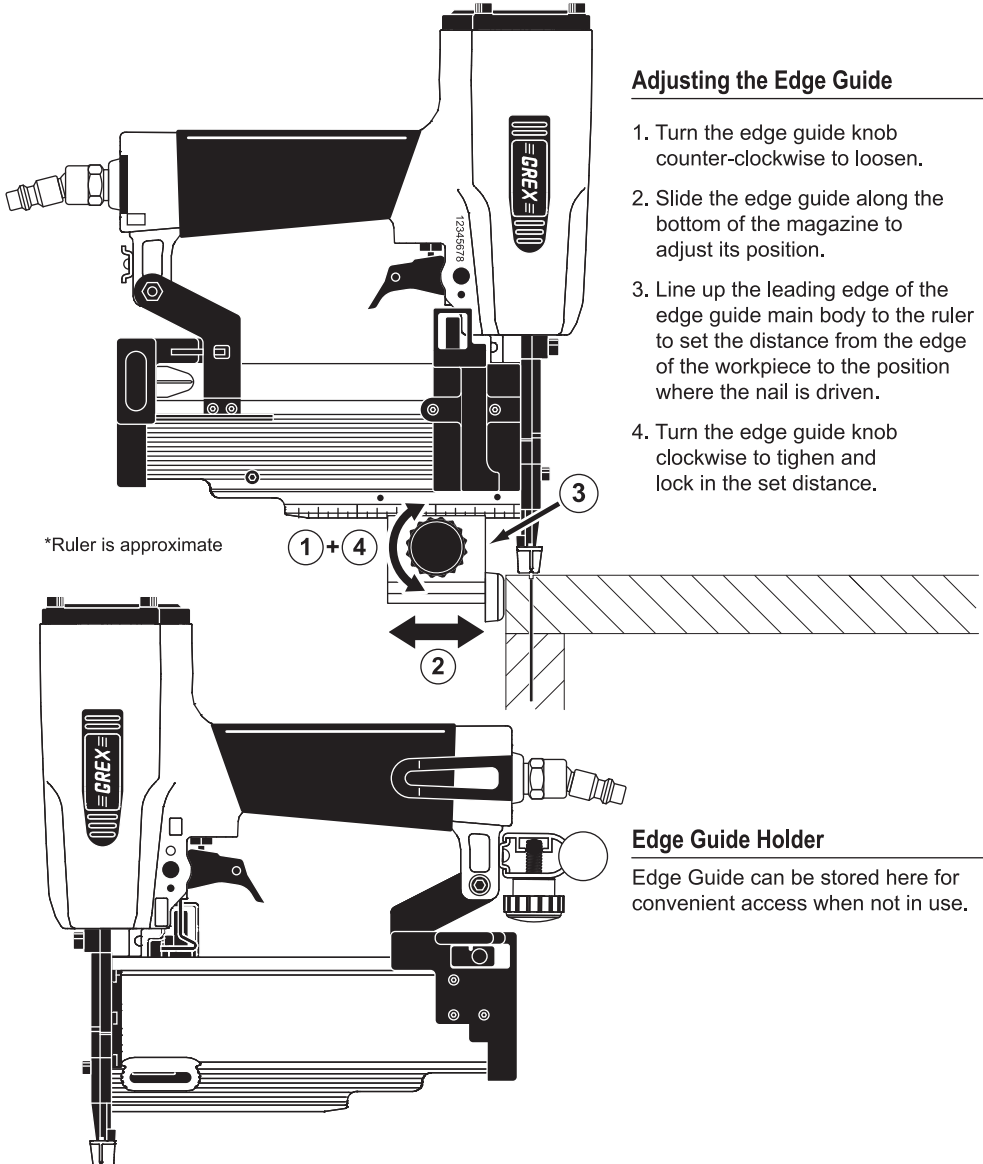

Adjusting the Edge Guide

1. Turn the edge guide knob counter-clockwise to loosen.
2. Slide the edge guide along the bottom of the magazine to adjust its position.
3. Line up the leading edge of the edge guide main body to the ruler to set the distance from the edge of the workpiece to the position where the nail is driven.
4. Turn the edge guide knob clockwise to tighten and lock in the set distance.

Edge Guide Holder

Edge Guide can be stored here for convenient access when not in use.

5.8 NO-MAR RUBBER TIP

The removable rubber tip prevents marring of your work material. It can also be easily removed and stored for safe-keeping behind the magazine cover end cap. Markings on the side of the tip create a 4-point alignment guide to precisely place fasteners.



WARNING: When detaching or attaching the no-mar tip, be sure to first disconnect the air hose from the tool and remove your finger from the trigger area.

Attaching the Rubber Tip - Firmly push tip onto the end of the safety as shown in **Fig. A**. To ensure the tip locks securely onto the safety, position the taller side of the tip towards the back.

Detaching the Rubber Tip - Slightly twist the no-mar tip backwards and pull off from the tool.

No-Mar Tip Storage - When the no-mar rubber tip is not necessary, it can be easily removed and stored for safe-keeping behind the magazine cover end cap. **Fig. B**

4-Point Alignment Guide - Markings on the side of the tip create a 4-point alignment guide to precisely place fasteners. As shown in **Fig. C**, the markings on each side of the tip indicates the precise location where fastener will be driven. Simply align the four marks as a target shown in the figure.

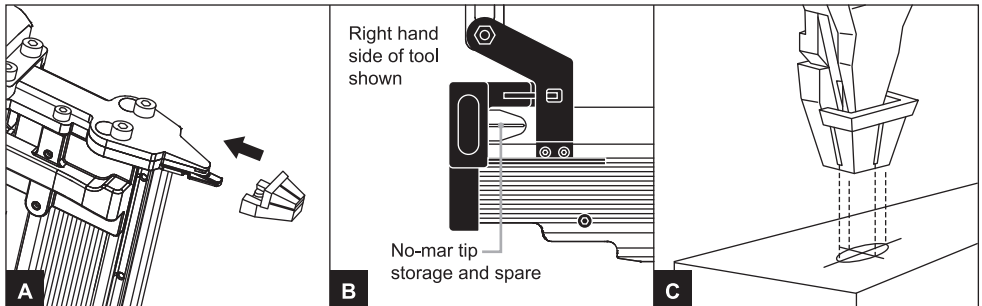

5.9 ADJUSTABLE BELT HOOK

The integrated belt hook allows the tool to be conveniently hung on your tool belt, thereby by freeing both of your hands to reposition your work piece and/or safely move up and down a ladder.

This belt hook, by default, is mounted on the tool for a right handed operator, however, it can easily be adjusted to accommodate a left handed operator by following these steps.

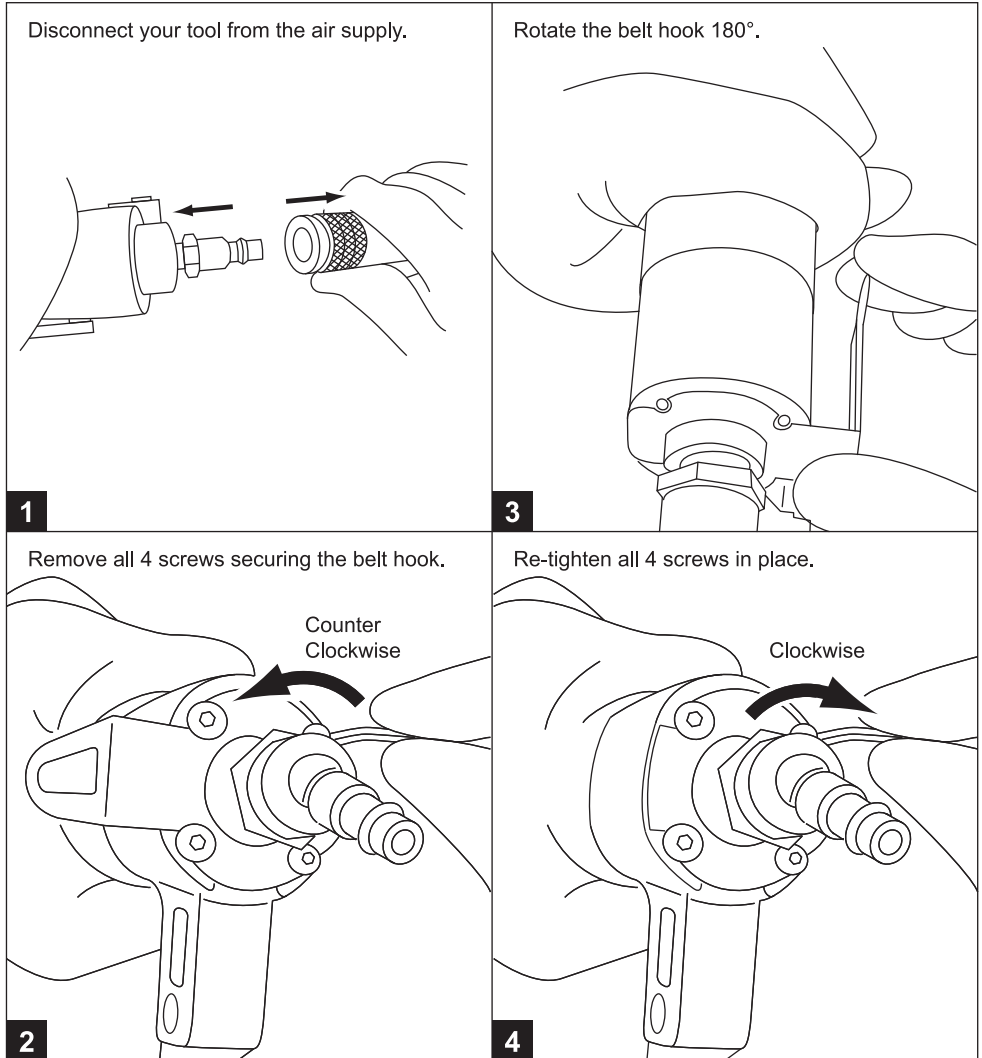

6.1 CLEARING JAMMED FASTENERS

Disconnect air hose from tool and remove any remaining fasteners in magazine. Remove no-mar rubber tip.

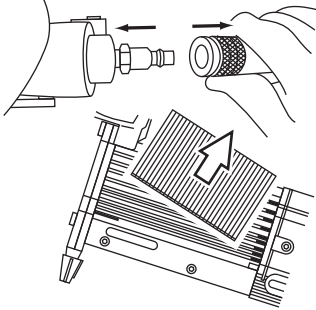

1

Remove the jammed fastener. It may be necessary to use a needle nose plier.

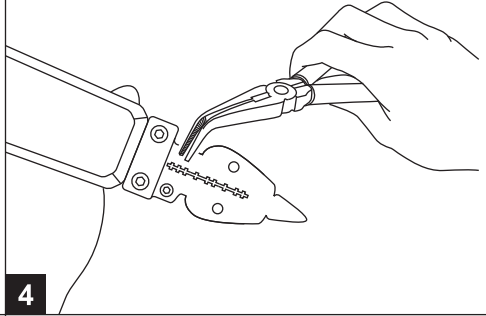

4

Loosen front nose plate screws using 3mm hex key stored on tool. Then slide down and lift off the front plate.

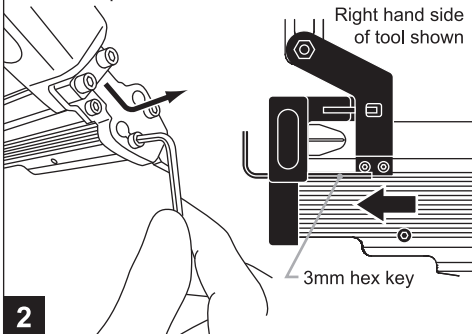

2

Align nose plate with screws, plate guide and driver blade. Then slide completely up.

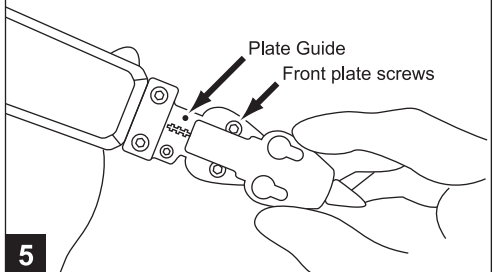

5

If the driver blade is in the down position, gently and carefully push it back into the tool. A flat-head screwdriver or something with a flat surface may be necessary.

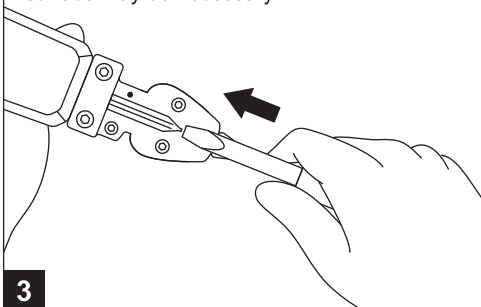

3

Tighten the front nose plate screws securely.

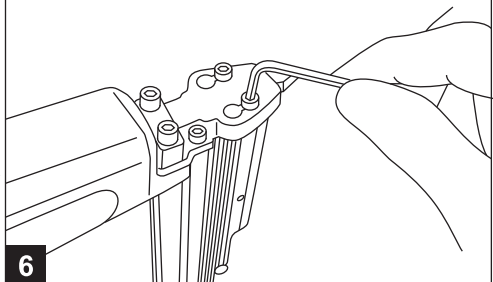

6



WARNING: Read section titled "Safety Instructions" on page 1 before performing maintenance and inspection on tool.

6.2 CLEAN AND INSPECT DAILY

DANGER: Never use gasoline or other flammable liquids to clean the tool. Vapors in the tool will ignite by a spark and cause the tool to explode and result in death or serious injury.

Wipe tool clean

Use non-flammable cleaning solutions to wipe exterior of tool only if necessary. **DO NOT SOAK** tool with cleaning solutions, such solutions can damage internal parts.

Remove tar buildup

Use kerosene #2 fuel oil or diesel fuel. Do not allow solvent to get into cylinder or damage may occur.

CAUTION: Dry off tool completely before use.

Clean the magazine

Remove wooden chips which may have accumulated in the magazine. Lubricate with tool lubricant.

CAUTION: Check that the magazine cover slides smoothly by pulling it with a finger. If not smooth, fasteners can be driven at an irregular angle and injure someone.

Maintain compressed air system

Drain air line filter daily to prevent accumulation of moisture and dirt by opening the manual petcock on your compressor. Keep lubricator filled to maintain proper lubrication to tool. Clean air filter element to prevent clogging of filter with dirt. Also drain the air compressor when not in use. **ALWAYS** follow your compressor's owner's manual for safe and proper operation.

6.3 LUBRICATION

1. Tool requires lubrication before first time use and occasionally depending on frequency of usage.
2. First disconnect the air supply from the tool before lubricating.
3. Put in a drop of spindle oil UNOCAL RX22, or 3-in-1 oil into air inlet. Never use detergent oil or additives. Operate tool briefly after adding oil.
4. Wipe off excess oil at exhaust. Do not over lubricate, excessive oil will damage o-rings, and can mix with spent air which may stain the work surface. Blank fire the nailer (without fasteners) to purge excess oil before beginning work.

If in-line oiler is used (refer to section titled "Compressed Air System" for more information), manual lubrication through the air inlet is not required on a daily basis.

6.4 STORAGE

- When not in use for an extended period, apply a thin coat of lubricant to the steel parts to avoid rust.
- Do not store tool in a cold weather environment. Keep tool in a warm area.
- When not in use, the tool should be stored in a warm and dry area - out of reach of children.



WARNING: Read section titled "Safety Instructions" on page 1 before performing maintenance and inspection on tool.

6.5 COLD WEATHER CARE

Do not store your tool in a cold weather environment. Keep your tool in a warm area until the beginning of work. If the tool is already cold, bring it to a warm area and use the following procedures to warm up the components:

1. Reduce regulated pressure to 70 psi.
2. Remove **ALL** fasteners from tool.
3. Connect air hose & blank fire the tool. Slow speed operation tends to warm up moving parts.
4. Once tool is warmed up, re-adjust regulator to working pressure and reload tool by following the instructions in the "Tool Operation" section on page 8.

6.6 TROUBLESHOOTING



WARNING

Read section titled "Safety Instructions" before attempting to troubleshoot tool.

Stop using the tool immediately if any of the following problems occur. Serious personal injury could occur. Most minor problems can be resolved quickly and easily by the table below. If problems persist, contact Grex or an authorized service center only.

Disconnect tool from air supply before performing any service procedures.

Symptom	Possible Cause	Remedy
Fasteners will not drive deep enough.	Driver blade rounded off and slipping off fastener head or broken.	Replace driver blade.
	Air pressure too low.	Increase to adequate air pressure.
Fasteners driven too deeply.	Worn bumper.	Replace bumper.
	Excessive air pressure.	Reduce to adequate air pressure.
Tool operates, but no fastener is driven.	There is a jam.	Clear jam.
	Pusher spring weakened or damaged.	Replace pusher spring.
Fastener misfire (skips).	Worn bumper.	Replace bumper.
	Dirt in nose.	Clean.
	Dirt or damage prevents fasteners from moving freely in magazine.	Clean and/or repair magazine .
	Inadequate air flow to tool.	Check fitting hose of air compressor.
	Worn o-ring on piston or lack of lubrication.	Replace o-ring or lubricate.
	Damaged o-ring in trigger valve.	Replace o-rings.
	Air leaks.	Tighten screws and fittings.
	Cap seal leaking.	Replace seal.
Air leaks between housing and nose.	Loose screws in housing.	Tighten screws.
	Damaged o-rings.	Replace o-rings.
	Damaged bumper.	Replace bumper.
Sluggish operation or power loss.	Tool not lubricated sufficiently.	Lubricate tool.
	Worn out o-rings.	Replace o-rings.
	Exhaust port in cap is blocked.	Replace damaged internal parts.
Fastener jamming.	Driver guide worn or damaged.	Replace driver guide.
	Fastener size not correct.	Fasteners recommended for tool must be used.
	Fasteners are bent.	Replace with undamaged fasteners.
	Magazine or nose screws loose.	Tighten screws.
Air leaks at trigger valve area.	O-rings in trigger valve are damaged.	Replace o-rings.

GreX Power Tools One Year Limited Warranty

GreX Power Tools warrants its professional power tools are to be free of defects from workmanship and material for a period of one year from the date of original date of purchase (exceptions: rubber o-rings, bumpers, seals & driver blades). We will repair or replace at our option, any parts of the product and accessories covered under this warranty, which after examination, proves to be defective in workmanship or material during the warranty period. For repair or replacement, contact GreX directly. Proof of purchase may be required.

This warranty does not apply to repair or replacement required due to misuse, abuse, normal wear and tear or repairs and alterations attempted or made by other than our Service Center or Authorized Service Stations. In no event shall GreX be liable for any indirect, incidental, or consequential damage from the sale or use of this product. This disclaimer applies both during and after the term of warranty.

This is the only warranty and our company makes no warranties expressed or implied, including merchantability and fitness for a particular purpose, after the one year term of this warranty.

This limited warranty gives you specific rights, and you may also have other rights, which vary from state to state.

All information, text and images contained in this publication are the property of GreX Power Tools. Unauthorized distribution, duplication, appropriation or reproduction in whole or in part is strictly prohibited.

© 2017 GREXUSA. All Rights Reserved.

GREX POWER TOOLS

1090 Monterey Pass Rd, Monterey Park, CA 91754
Tel. 323-318-2828 Fax. 323-318-2823
www.grexusa.com