

# Product & Packaging Specs

## JAWS II Full Wrap

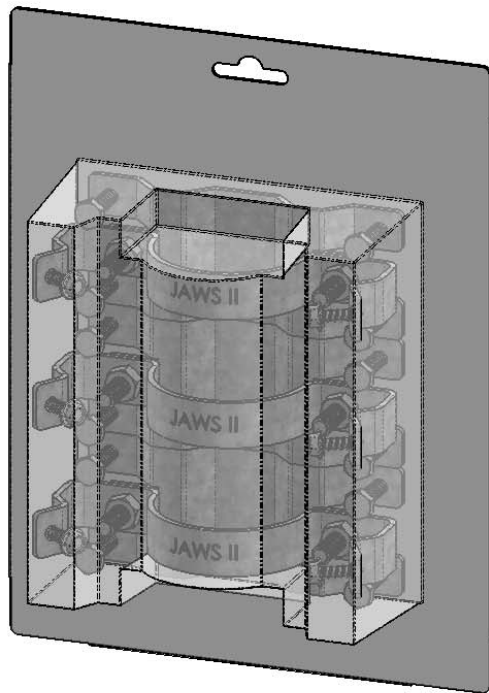

52803  
(3 Pack)

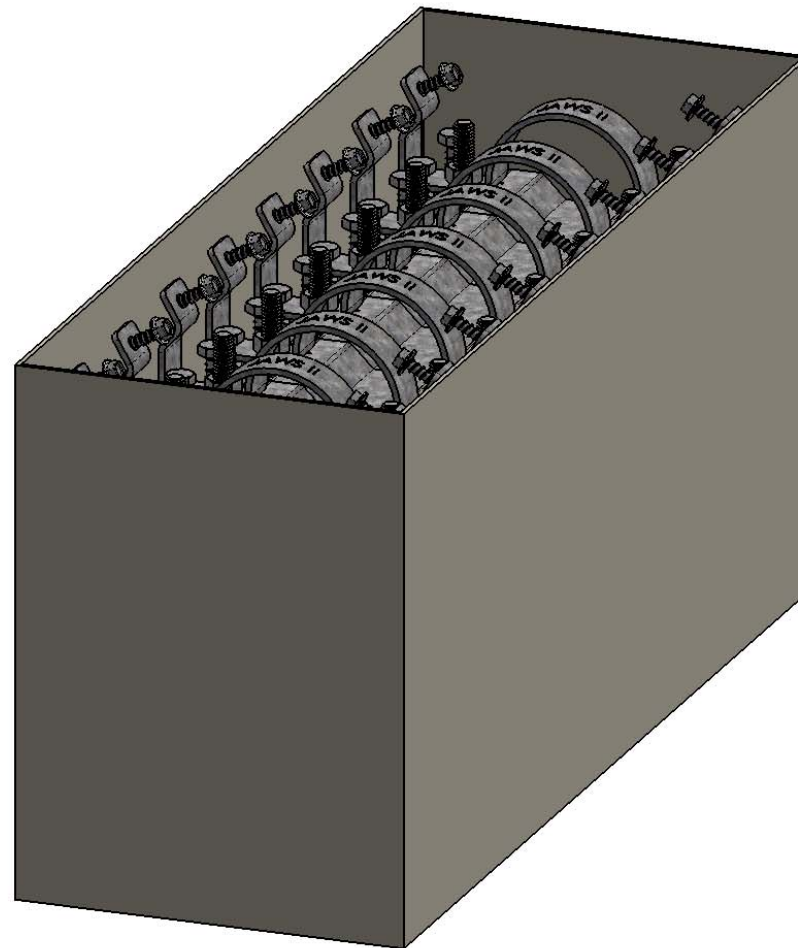

box shown  
without flaps  
for clarity

52824  
(24 Pack)



**OZCO** BUILDING PRODUCTS

# Product & Packaging Specs

## JAWSII Full Wrap

Item #: 50899

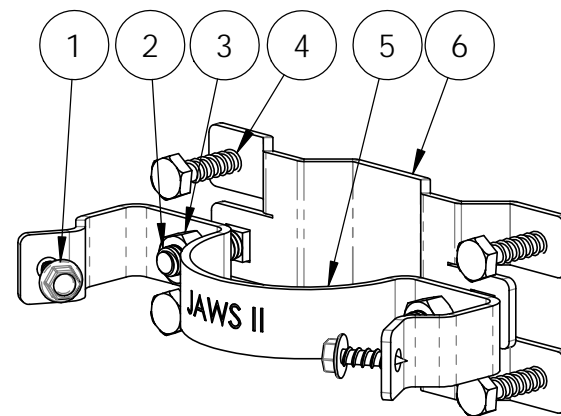
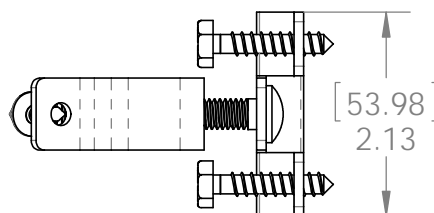
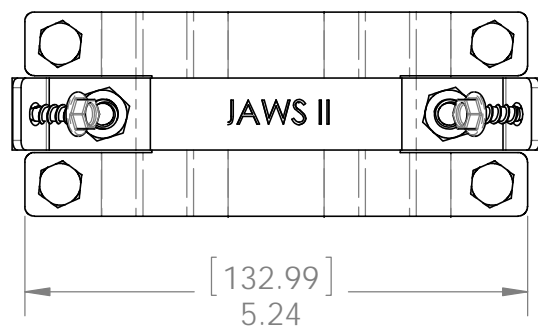
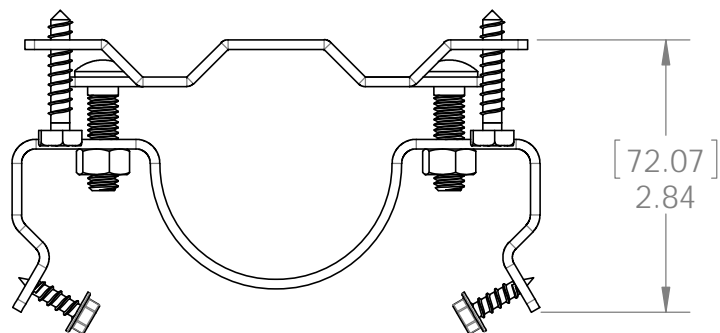

ITEM NO.	QTY.	PART NUMBER	DESCRIPTION
1	2	80520	Screw, 1/4-10" x 17mm, Flange Head Lag
2	2	Lag Bolt 5-16-18 x 30mm	Bolt, Carriage 5/16-18 x 30mm
3	2	80125	Nut, Hex 5/16-18
4	4	80055	Screw, Lag, 1/4" x 1-1/4"
5	1	50899-11	Bracket, JAWSII Full Wrap
6	1	50898-11	Bracket, JAWS Chassis

Weight: 13.31 LBS  
 Scale: 1:2  
 Last updated: 6/15/2015

Fasten-Ready Technology (pre-assembled as shown)



V1.00 - Installation Instructions effective May 1, 2015 and reflects information that available as of April 10, 2014. This information is updated periodically and should not be relied upon after May 1, 2015. Please visit [www.OZCOBP.com](http://www.OZCOBP.com) to get current information

50899

# Product & Packaging Specs

JAWS II Full Wrap

Item #: 50899

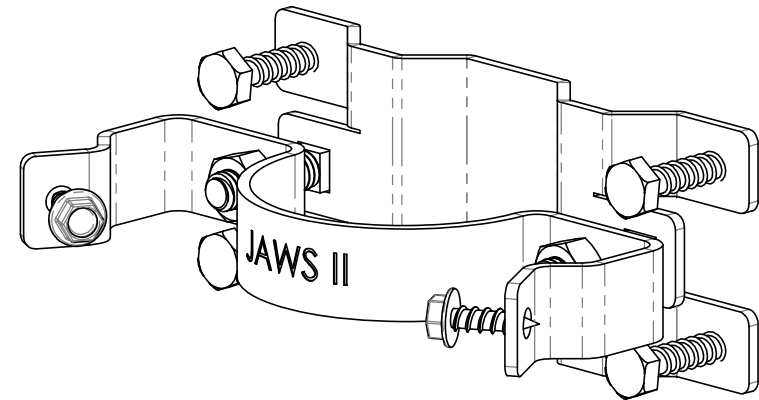
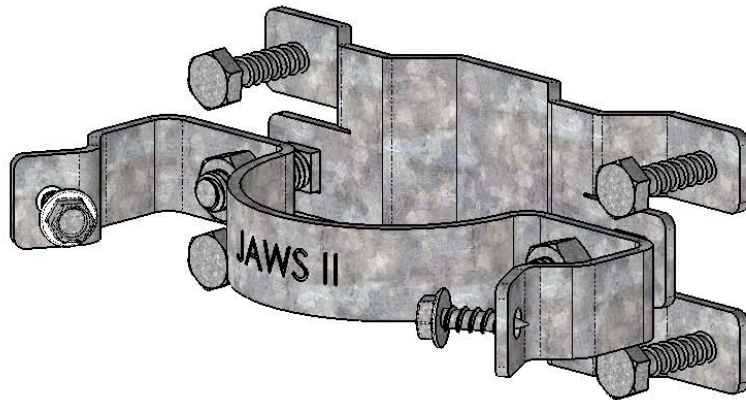

Weight: 13.31 LBS  
Scale: 1:1.5  
Last updated: 6/15/2015

50899

**JAWS II**

**OZCO** BUILDING PRODUCTS

V1.00 - Installation Instructions effective May 1, 2015 and reflects information that available as of April 10, 2014. This information is updated periodically and should not be relied upon after May 1, 2015. Please visit [www.OZCOBP.com](http://www.OZCOBP.com) to get current information

# Product & Packaging Specs

## JAWSII Full Wrap

Item #: Typical Installation & Basic Assembly

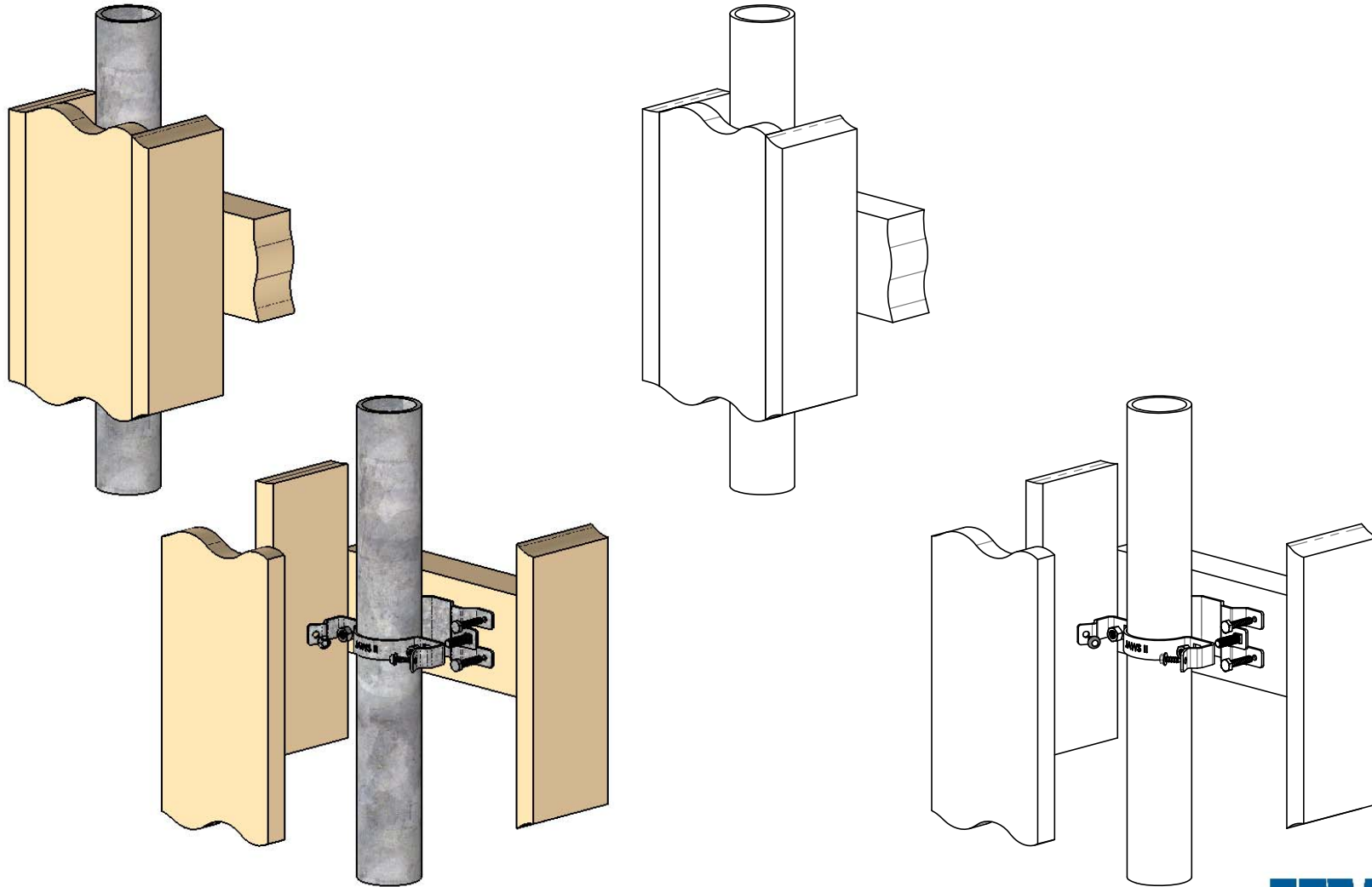

Weight: 13.31 LBS  
Scale: 1:6  
Last updated: 6/15/2015

50899

**JAWSII**  
FORME SPACETECH

**OZCO** BUILDING PRODUCTS

V1.00 - Installation Instructions effective May 1, 2015 and reflects information that available as of April 10, 2014. This information is updated periodically and should not be relied upon after May 1, 2015. Please visit [www.OZCOBP.com](http://www.OZCOBP.com) to get current information

# Product & Packaging Specs

## JAWSII Full Wrap

Item #: Typical Installation & Basic Assembly

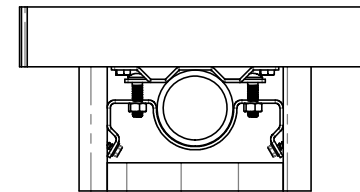
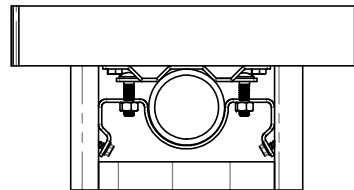
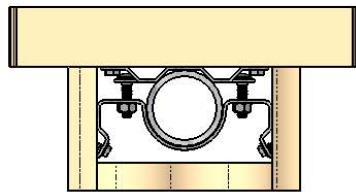

[139.70]  
5.50

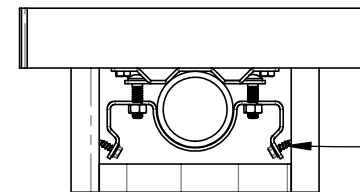
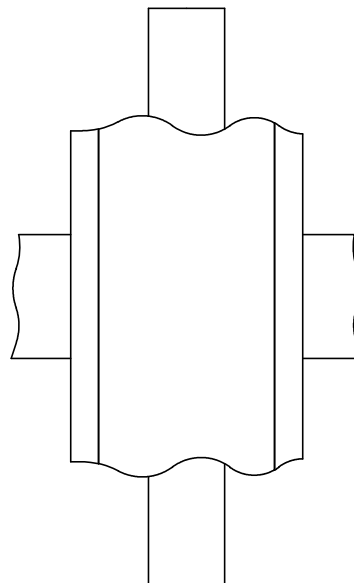
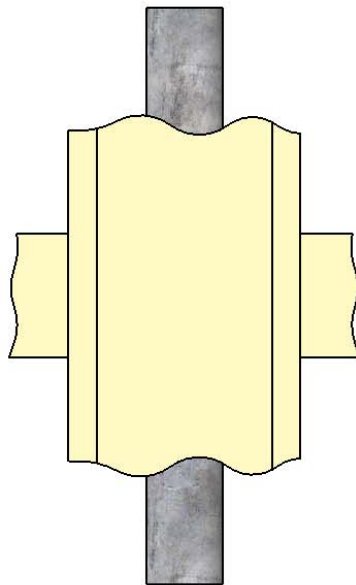

[152.40]  
6.00

tighten until  
bracket  
touches  
wood on  
wider boards

Weight: 13.31 LBS  
Scale: 1:6  
Last updated: 6/15/2015

50899



V1.00 - Installation Instructions effective May 1, 2015 and reflects information that available as of April 10, 2014. This information is updated periodically and should not be relied upon after May 1, 2015. Please visit [www.OZCOBP.com](http://www.OZCOBP.com) to get current information

# Product & Packaging Specs

## JAWSII Packaging Back

Item #: Packaging Back

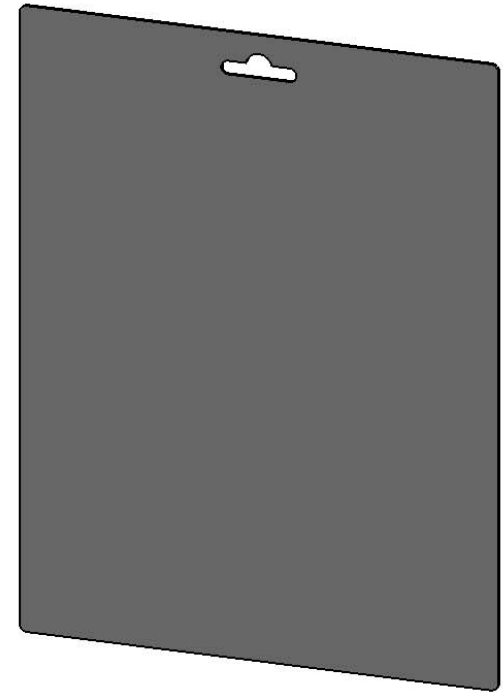
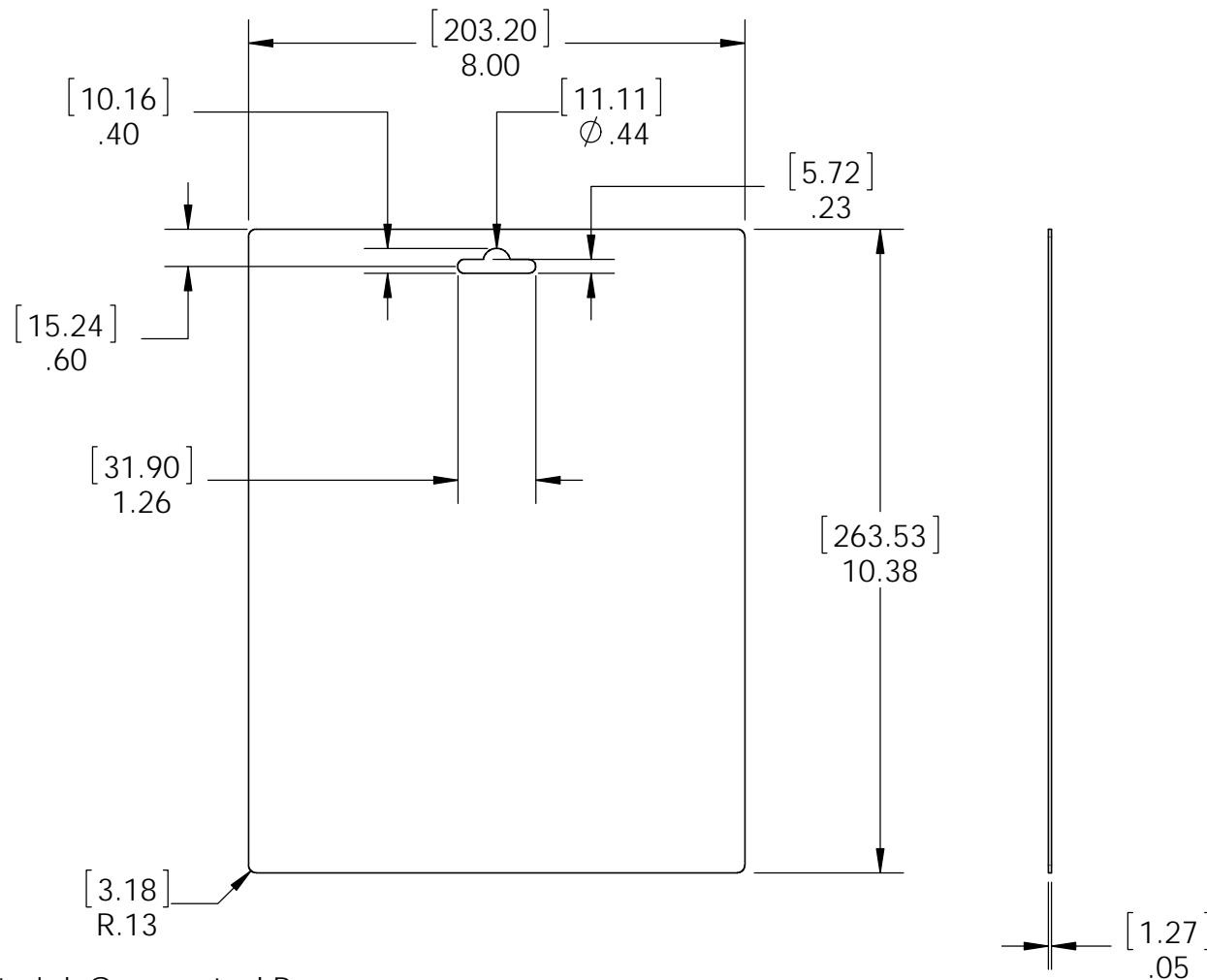

Material: Corrugated Paper  
Finish: See Artworks  
Weight: 0.02 LBS  
Scale: 1:8  
Last updated: 6/15/2015

50899



V1.00 - Installation Instructions effective May 1, 2015 and reflects information that available as of April 10, 2014. This information is updated periodically and should not be relied upon after May 1, 2015. Please visit [www.OZCOBP.com](http://www.OZCOBP.com) to get current information

# Product & Packaging Specs

## 50899 Packing

Item #: 52803 (3 Pack)

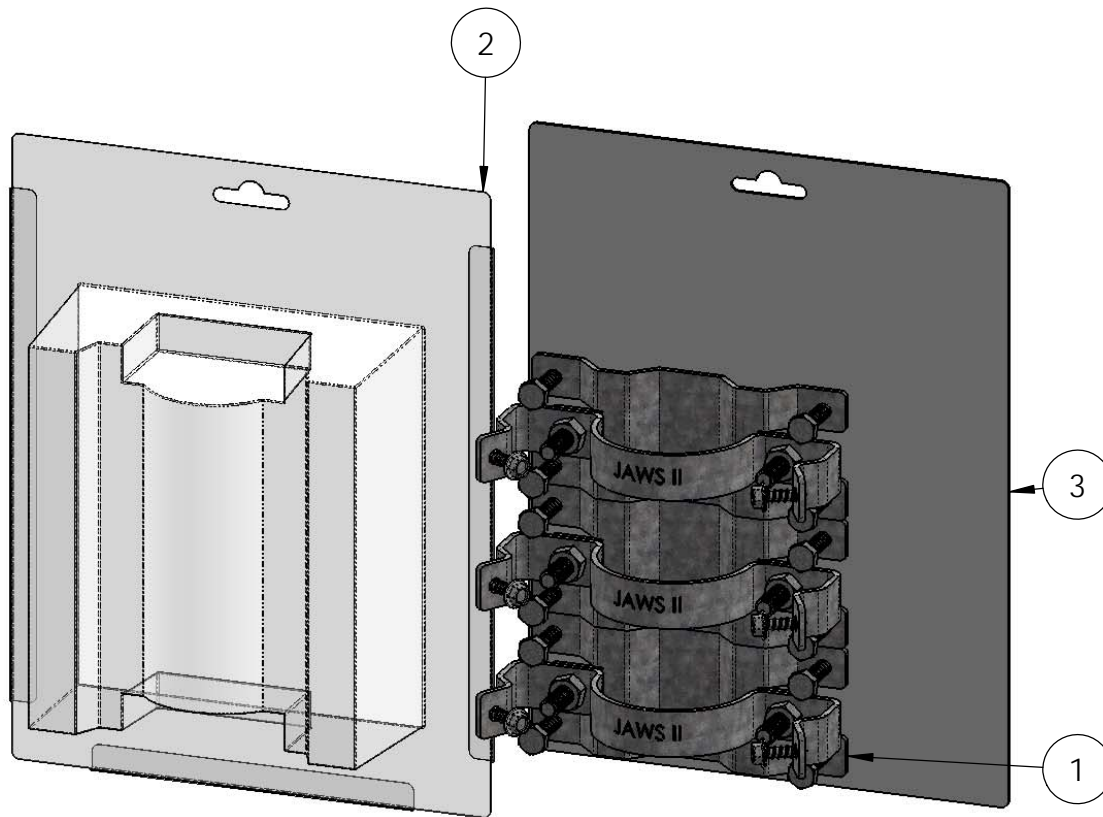

ITEM NO.	QTY.	PART NUMBER	DESCRIPTION
1	3	50899	JAWSII Full Wrap
2	1	JAWSII Packaging	JAWSII Packaging
3	1	JAWSII Packaging Back	JAWSII Packaging Back

Weight: 2.20 LBS  
 Scale: 1:3  
 Last updated: 6/15/2015

50899



V1.00 - Installation Instructions effective May 1, 2015 and reflects information that available as of April 10, 2014. This information is updated periodically and should not be relied upon after May 1, 2015. Please visit [www.OZCOBP.com](http://www.OZCOBP.com) to get current information

# Product & Packaging Specs

Case **Packaging**

Item #: **51804**

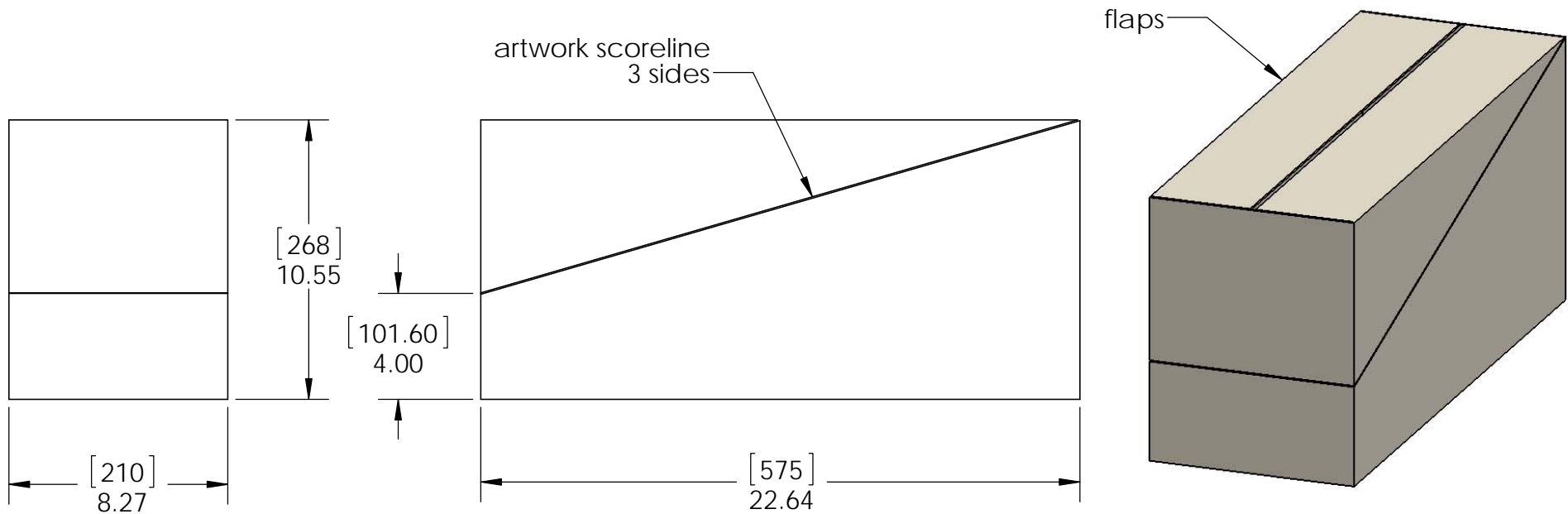

Material: Corrugated Paper  
Finish: See artworks  
Weight: 0.45 LBS  
Scale: 1:6  
Last updated: 6/15/2015

50899



**OZCO** BUILDING PRODUCTS

V1.00 - Installation Instructions effective May 1, 2015 and reflects information that available as of April 10, 2014. This information is updated periodically and should not be relied upon after May 1, 2015. Please visit [www.OZCOBP.com](http://www.OZCOBP.com) to get current information



# Product & Packaging Specs

**Case Packing**

Item #: **51804**

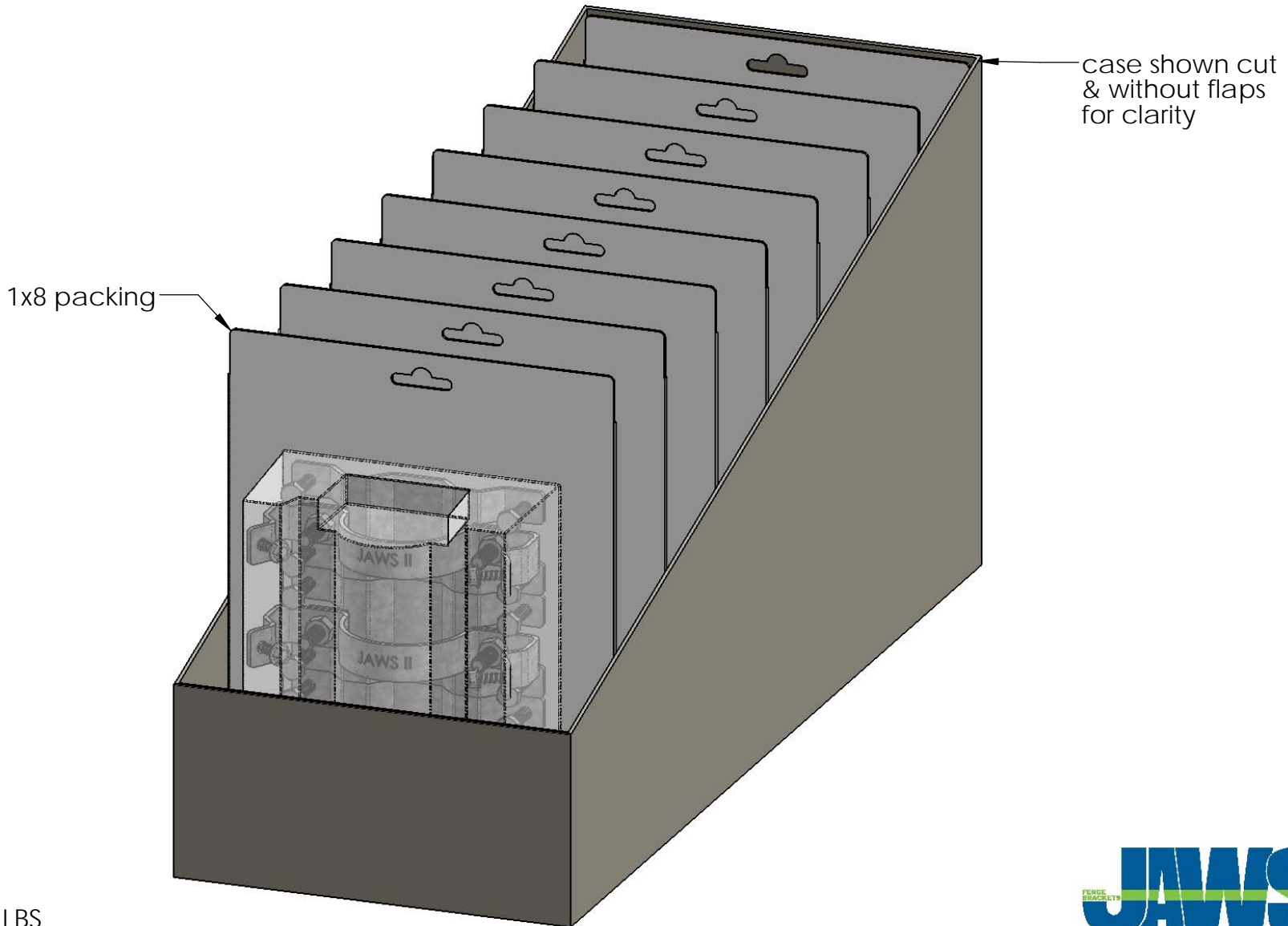

Weight: 18 LBS  
Scale: 1:3  
Last updated: 6/15/2015

50899



V1.00 - Installation Instructions effective May 1, 2015 and reflects information that available as of April 10, 2014. This information is updated periodically and should not be relied upon after May 1, 2015. Please visit [www.OZCOBP.com](http://www.OZCOBP.com) to get current information

# Product & Packaging Specs

**Pallet Packing**

Item #: **51825**

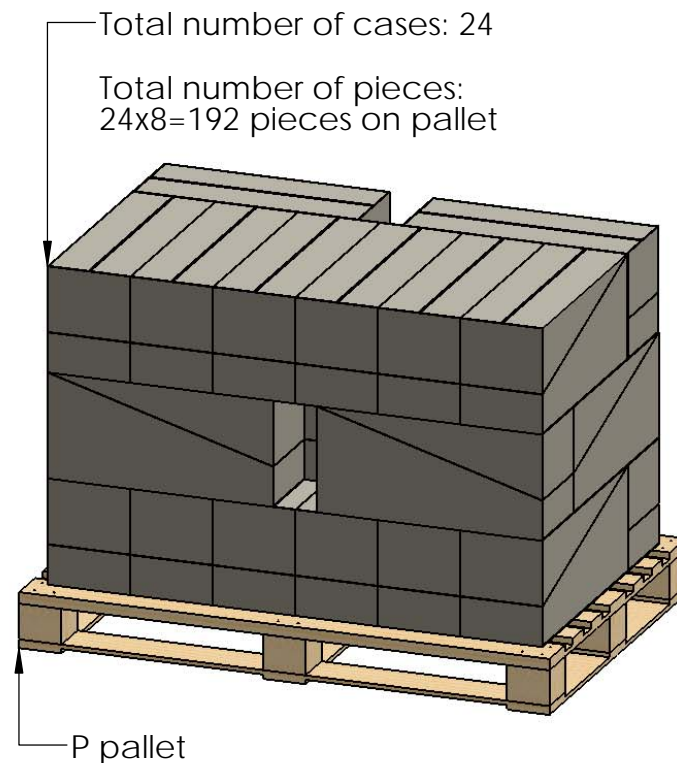
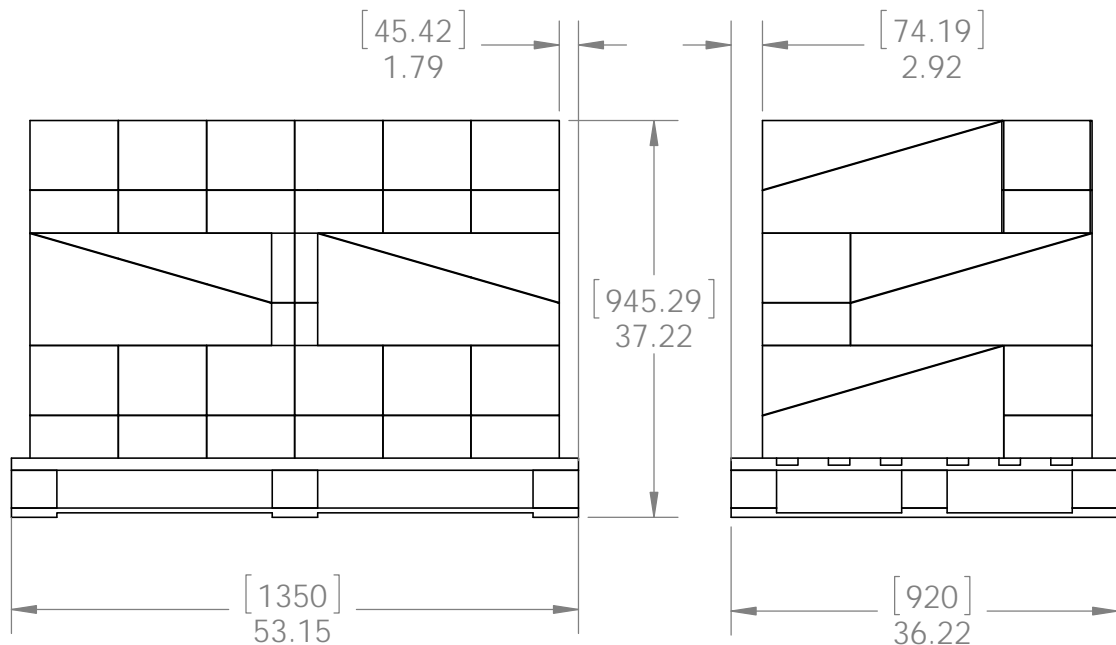

additional pallet packing instructions  
plywood on top layer  
strap to pallet  
clear wrap around boxes

**JAWS II**

**OZCO BUILDING PRODUCTS**

V1.00 - Installation Instructions effective May 1, 2015 and reflects information that available as of April 10, 2014. This information is updated periodically and should not be relied upon after May 1, 2015. Please visit [www.OZCOBP.com](http://www.OZCOBP.com) to get current information

Weight: 463 LBS  
Scale: 1:18  
Last updated: 6/15/2015

50899

# Product & Packaging Specs

**Bulk Pack** (24 pack)

Item #: **52824**

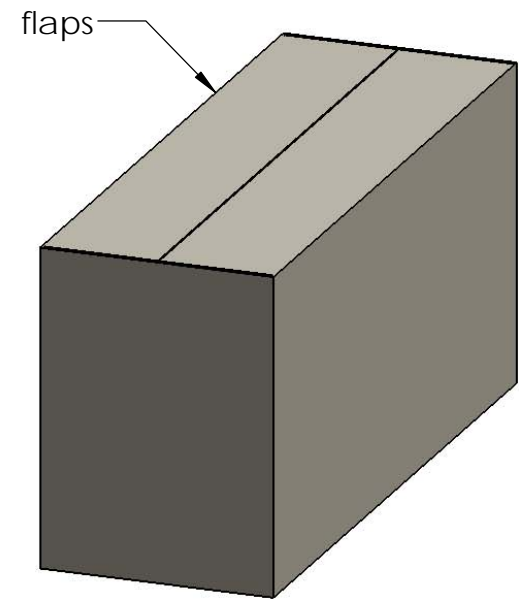
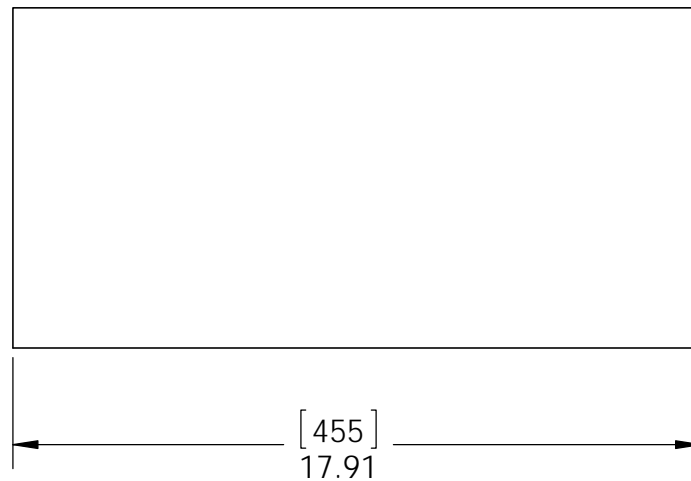
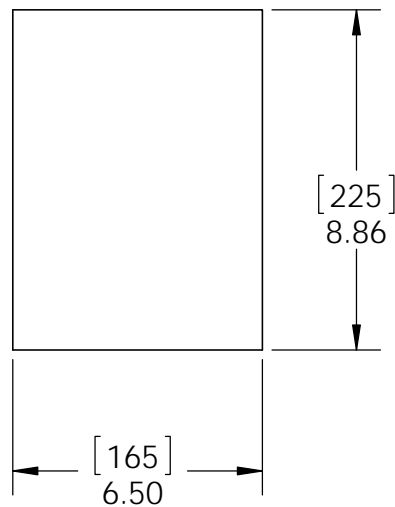

Material: Corrugated Paper  
Finish: See artwork  
Weight: 0.29 LBS  
Scale: 1:5  
Last updated: 6/15/2015

50899



V1.00 - Installation Instructions effective May 1, 2015 and reflects information that available as of April 10, 2014. This information is updated periodically and should not be relied upon after May 1, 2015. Please visit [www.OZCOBP.com](http://www.OZCOBP.com) to get current information

# Product & Packaging Specs

**Bulk** Packing  
Item #: 52824 (24 Pack)

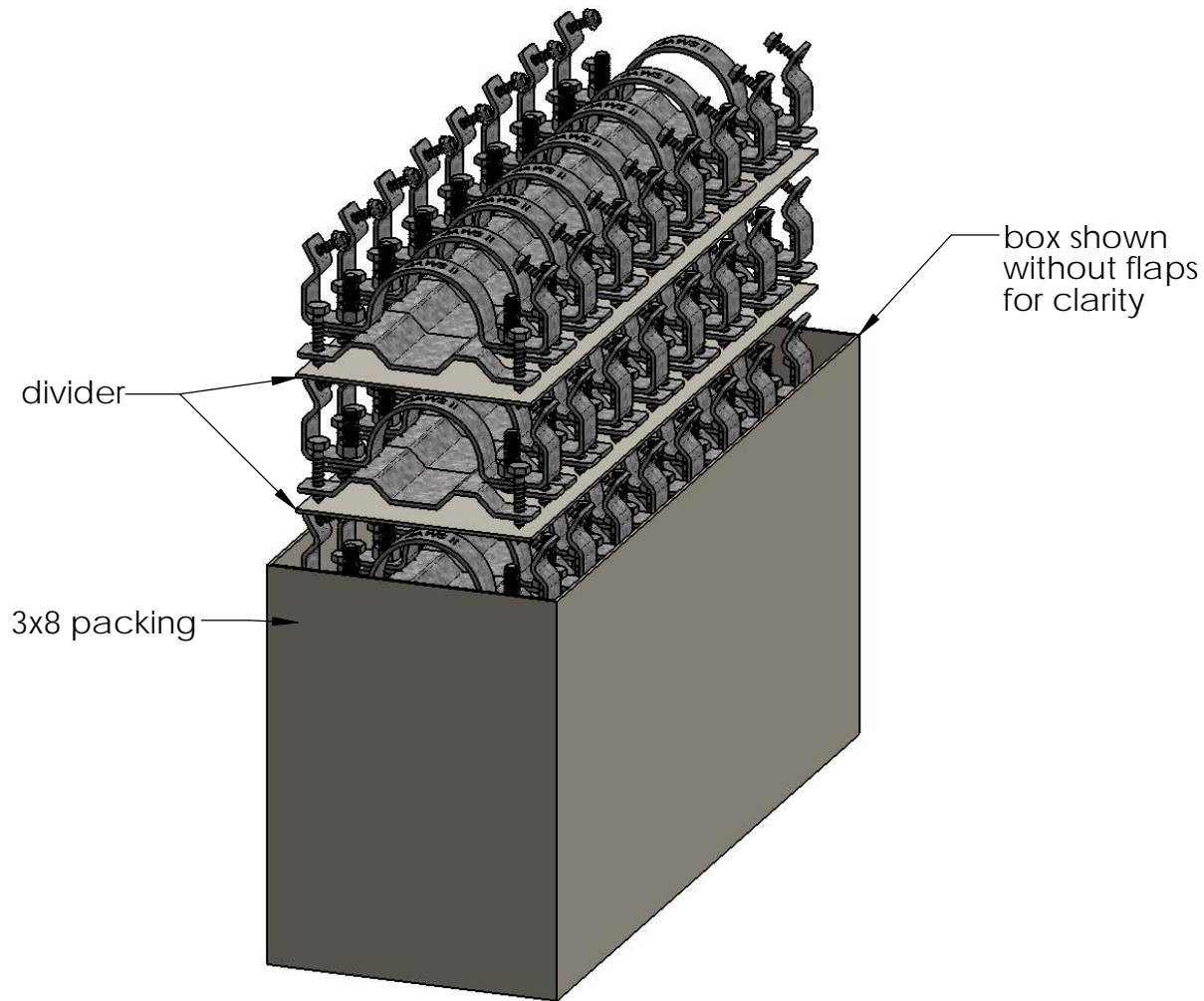

Weight: 17.24 LBS  
Scale: 1:4  
Last updated: 6/15/2015

50899



V1.00 - Installation Instructions effective May 1, 2015 and reflects information that available as of April 10, 2014. This information is updated periodically and should not be relied upon after May 1, 2015. Please visit [www.OZCOBP.com](http://www.OZCOBP.com) to get current information

# Product & Packaging Specs

**Pallet Packing**

Item #: **52825**

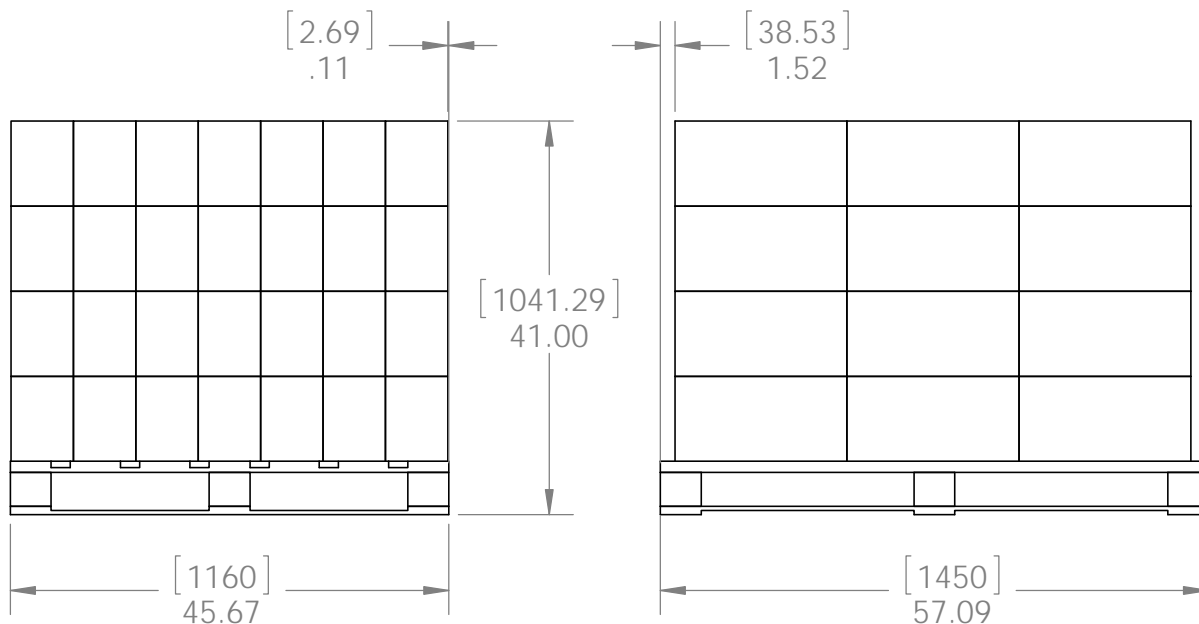

Total number of cases: 84  
 Total number of pieces: 84x24=2016 pieces on pallet

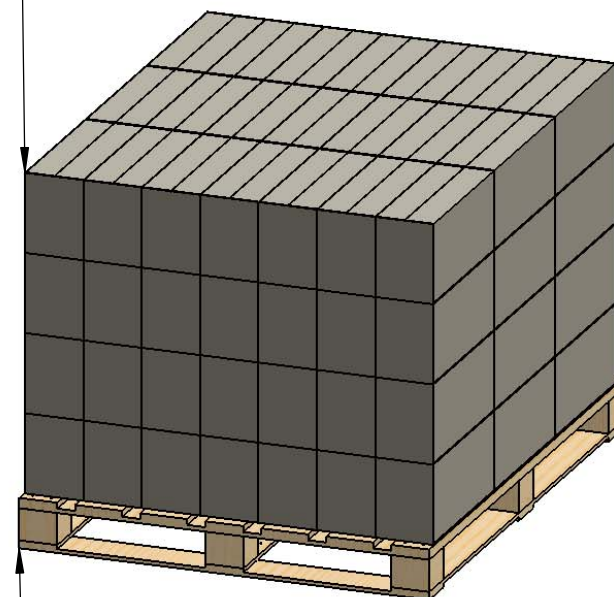

T pallet



additional pallet packing instructions  
 plywood on top layer  
 strap to pallet  
 clear wrap around boxes



**OZCO** BUILDING PRODUCTS

Weight: 1500 LBS  
 Scale: 1:20  
 Last updated: 6/15/2015

50899

V1.00 - Installation Instructions effective May 1, 2015 and reflects information that available as of April 10, 2014. This information is updated periodically and should not be relied upon after May 1, 2015. Please visit [www.OZCOBP.com](http://www.OZCOBP.com) to get current information