

Use and Care Guide

Dorm Space Saver

Item #SL-SSHD-34W
Model #0000000000



PACKAGE CONTENTS

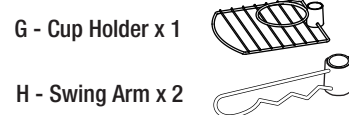
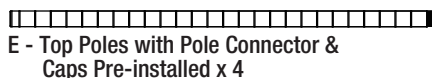
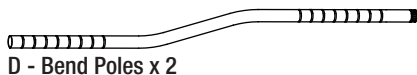
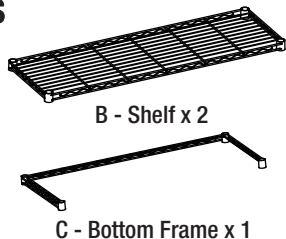
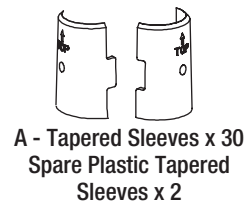

Assembly

1 Assembling the bottom frame

- Locate the desired position of the bottom frame (C). Ensure that it is no more than 6 in. from the floor.
- Place two tapered sleeves (A) into the appropriate groove on each pole assembly. Ensure the tapered end is up (see arrow on sleeve).
- Place the bottom frame (C) on its side and slide the each pole assembly with tapered locks through the bottom of the frame (C) until snug.
- After all pole assemblies are in place, position the unit in the upright position.
- Push down on each corner of the frame (C) and ensure the frame (C) is in a fully locked position.

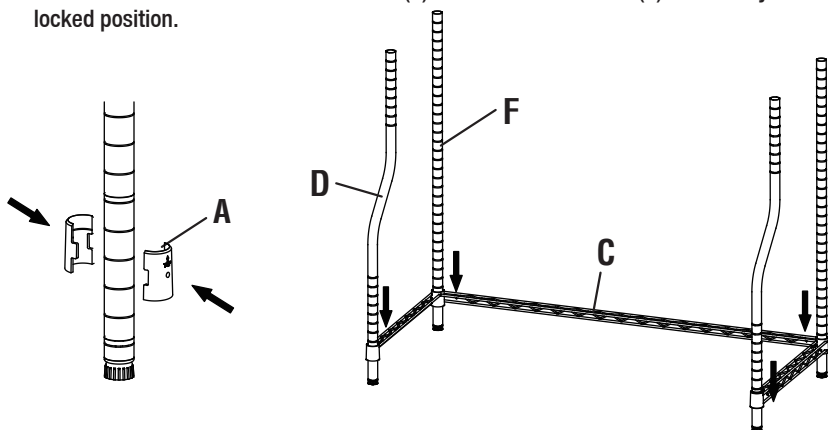

2 Assembling the posts

- Screw a top pole (E) to a bottom pole (F) and bend pole (D).

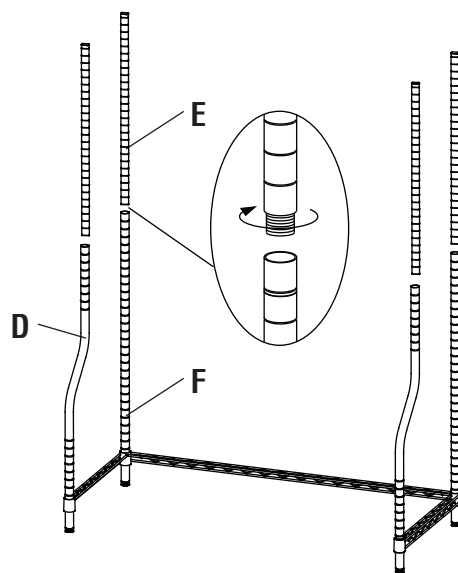

3 Assembling the racks

- Locate the desired position of the cup holder (G) and swing arm (H). Place the tapered sleeves (A) on to the pole assemblies.
- Slide the cup holder (G) down from the top of the pole assemblies and onto the tapered sleeves (A). Repeat for the remaining swing arm (H).

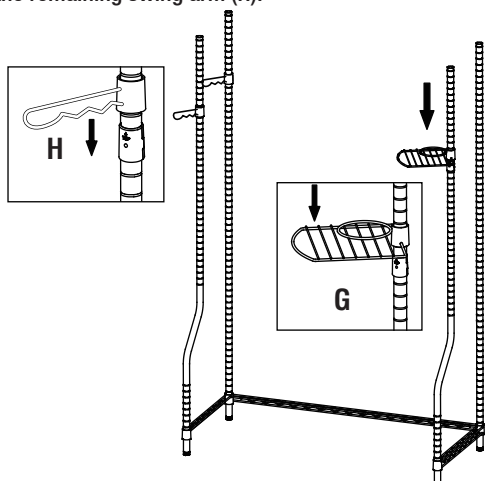

4 Assembling the shelf

- Locate the desired position of the shelf (B) and place the tapered sleeves (A) onto the pole assemblies.
- Slide the shelf (B) down from the top of the pole assemblies and onto the tapered sleeves (A).
- Push down on each shelf (B) corner, ensuring the shelf (B) is in a fully locked position.
- Repeat for the remaining shelf (B).

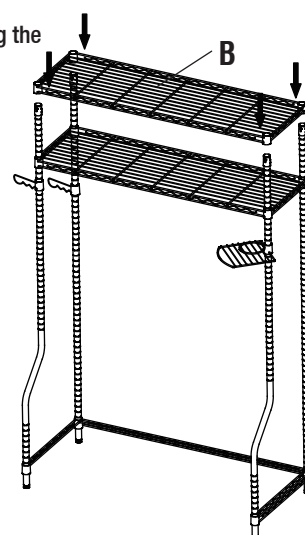

Tip resistant kit – fix to wall to prevent tipping over

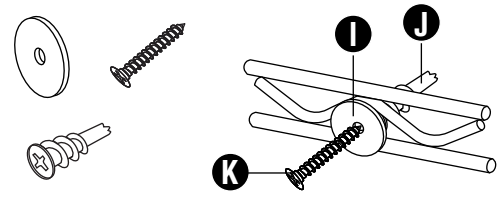

Safety Information

- Two adults are recommended for ease of assembly. Use care when handling.
- Assembly recommended on a soft surface, such as carpet, to avoid scratching flooring finish.
- Discard the black circular plastic pieces. These are used to separate the shelves for shipping purposes.



CAUTION: Do not allow children to climb or play in or around the shelves.



CAUTION: Each shelf holds up to 200 lbs, evenly distributed. Do not overload.



HOMEDEPOT.COM/HDX
Please contact 1-800-514-6729 for further assistance.
Monday-Friday 8 a.m. - 7 p.m. EST and Saturday 9 a.m. - 6 p.m. EST