



Item #1000 389 744/1000 131 565

Model #D9127-S/DY9127-S-R

USE AND CARE GUIDE

WOODBURY SOFA

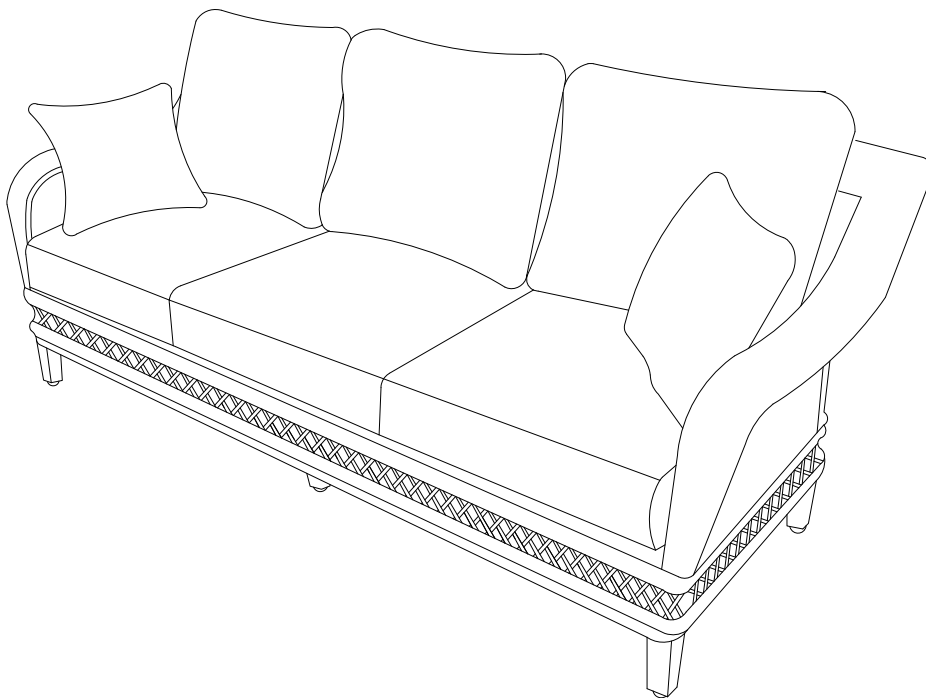

Questions, problems, missing parts? Before returning to the store,

call Hampton Bay Customer Service

8 a.m. - 7 p.m., EST, Monday-Friday

9 a.m. - 6 p.m., EST, Saturday

1-855-HD-HAMPTON

HAMPTONBAY.COM

THANK YOU

We appreciate the trust and confidence you have placed in Hampton Bay through the purchase of this sofa. We strive to continually create quality products designed to enhance your home. Visit us online to see our full line of products available for your home improvement needs. Thank you for choosing Hampton Bay!

Table of Contents

Table of Contents.....	2	Assembly	5
Warranty.....	2	Care and Cleaning	6
What is Covered.....	2		
What is Not Covered	2		
Pre-Assembly	3		
Planning Assembly	3		
Hardware Included	3		
Package Contents.....	4		

Warranty

THIS IS A RESIDENTIAL WARRANTY ONLY AND THIS WARRANTY DOES NOT APPLY TO COMMERCIAL USE

5 YEAR FRAME LIMITED WARRANTY/2 YEAR RESIN WEAVE AND FABRIC LIMITED WARRANTY

WHAT IS COVERED

We warrant the frame to be free of manufacturing defects to the original purchaser for five years and the resin weave and fabric for two years.

WHAT IS NOT COVERED

It remains the customer's responsibility for freight and packaging charges to and from our service center.

This warranty does not cover commercial use, hardware, acts of nature, fire, freezing, and abusive use.

In addition, purchased parts are not covered under this warranty. We reserve the right to make substitutions with similar merchandise, if the model in question is no longer in production.

For a copy of our full limited warranty, please contact our customer service team below.

Contact the Customer Service Team at 1-855-HD-HAMPTON or visit www.hamptonbay.com.

Pre-Assembly

PLANNING ASSEMBLY

Please read this entire instruction manual prior to assembly.

Identify all parts packed in the carton against the parts list. Remove all protective materials and place the parts on a non-abrasive surface to avoid scratching.



NOTE: More than one person may be required to complete the assembly of this product.

HARDWARE INCLUDED



NOTE: Tools not shown to actual size.

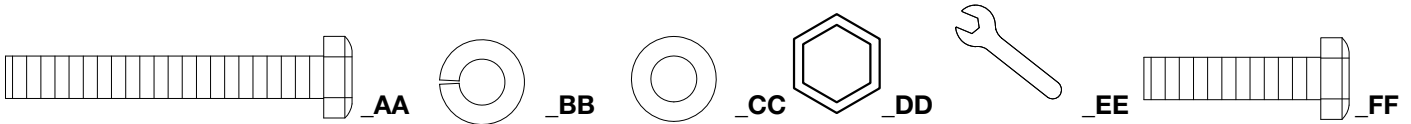

Part	Description	Quantity
AA	M6*45 Hex bolt	12
BB	Spring Washer	16
CC	Washer	16
DD	Caps	16
EE	M6 Wrench	1
FF	M6*25 Hex bolt	4

Pre-Assembly (continued)

PACKAGE CONTENTS

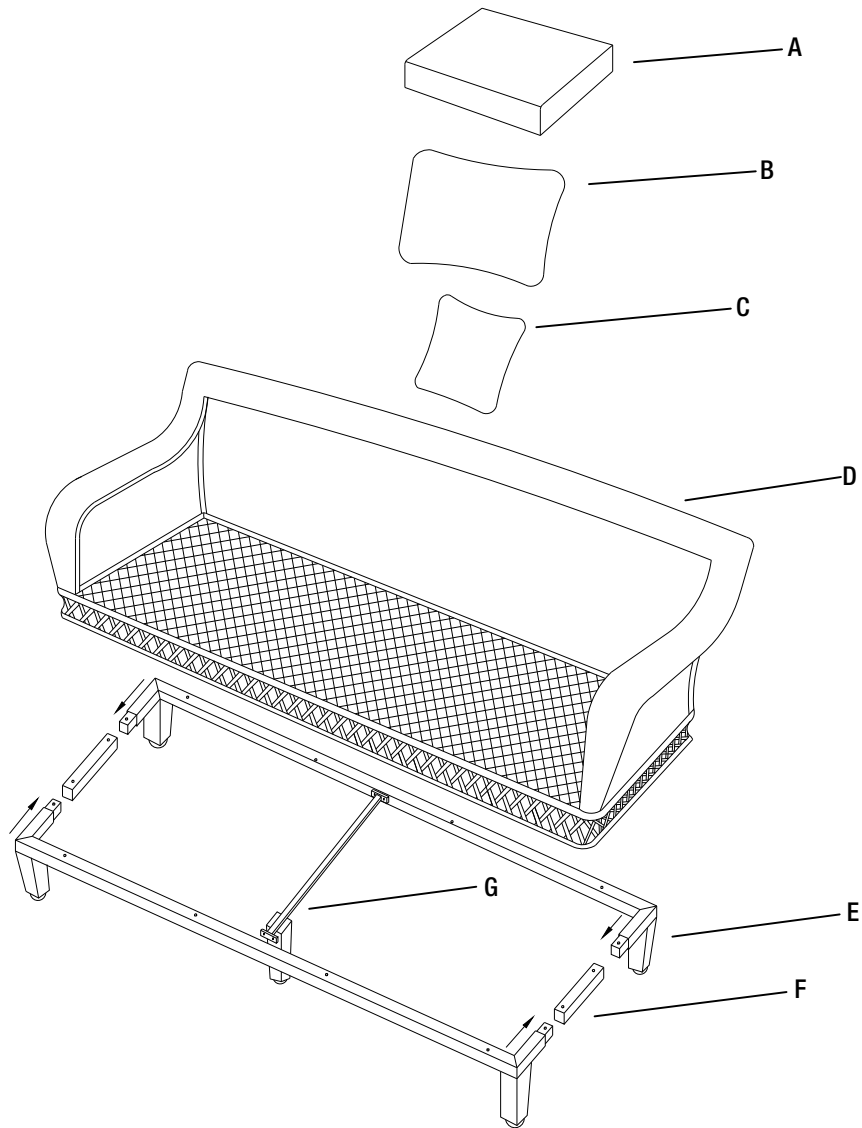

Part	Description	Quantity
A	Seat cushion	3
B	Back cushion	3
C	Pillow	2
D	Sofa body	1
E	Leg	2
F	Leg connector	2
G	Middle leg connector	1

Assembly

1 Assembling the legs

- Insert the legs (E) into both ends of the leg connectors (F) until they snap into place.



NOTE: No screws are needed in this step.

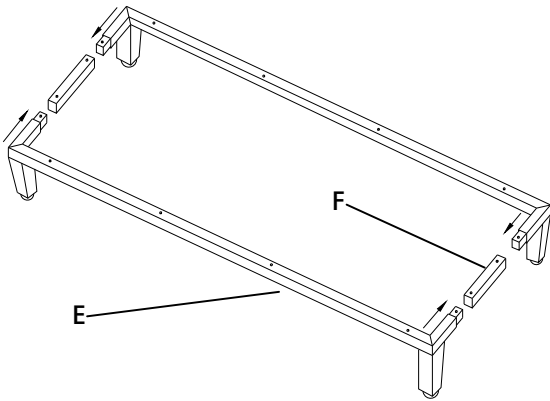

2 Attaching the legs to the sofa body

- Place the sofa body (D) upside down on a soft, flat non-abrasive surface. Attach the legs (E) and leg connectors (F) to the sofa (D) using M6*45 hex bolts (AA), spring washers (BB), and washers (CC). Attach the middle leg connector (G) to the legs (E), using M6*25 hex bolts (FF), spring washers (BB), and washers (CC).



NOTE: Please ensure all the bolts are assembled correctly and use the M6 wrench (EE) to tighten.

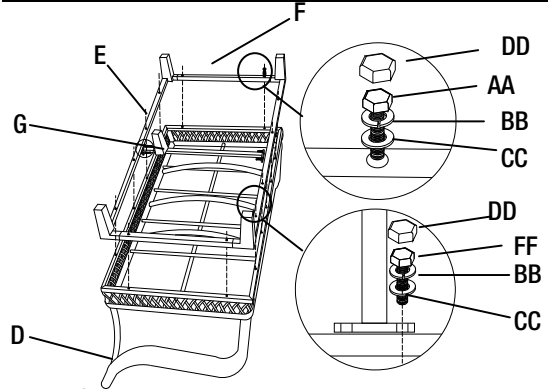

3 Positioning the sofa and adding the cushions

- With assistance, turn the sofa over and set it down on its legs.
- Place the seat cushions (A), back cushions (B) and pillows (C) on the sofa.

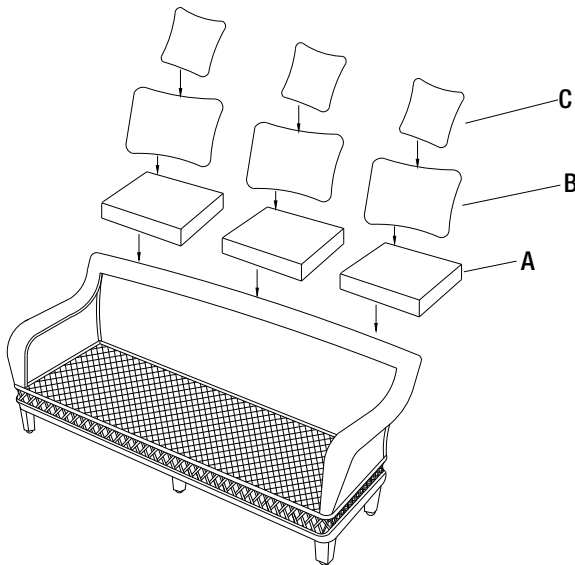

Care and Cleaning

- Do not allow water to build up in the frames. This will cause corrosion and possible freezing damage in cold climates.
- Use a mild soap and water for normal cleaning. Do not use janitorial or alcohol based cleaners. Some cleaners may be marked as natural, but some ingredients may cause discoloration or have an adverse reaction to your finish.
- Rinse with clean water and dry with a soft, absorbent cloth towel.
- Treat the frames with a liquid wax for maximum protection against UV rays and/or salty, damp air.



Questions, problems, missing parts? Before returning to the store,
call Hampton Bay Customer Service
8 a.m. - 7 p.m., EST, Monday-Friday
9 a.m. - 6 p.m., EST, Saturday

1-855-HD-HAMPTON

HAMPTONBAY.COM

Retain this manual for future use.