

**Duro**  
NEXT GENERATION

**Max**  
POWER SYSTEMS

# Gasoline **Chemical** Pump Owner's Manual



## DuroMax Customer Service

[customer\\_service@duromaxpowerequipment.com](mailto:customer_service@duromaxpowerequipment.com)

800-629-3325 Monday - Friday 7am to 5pm. PST



This manual provides information regarding the operation and maintenance of these products. We have made every effort to ensure the accuracy of the information in this manual. We reserve the right to change this product at any time without prior notice.

Please keep this manual available to all users during the entire life of the gasoline water pump.

## CONTENTS

1.	General Safeguards .....	4
2.	Location of Component Parts .....	6
3.	Operation before Starting Up .....	7
4.	Starting of Engine .....	12
5.	Use in High Altitude .....	14
6.	Operation of Water Pump .....	15
7.	Shutting Down the Engine .....	16
8.	Maintenance .....	17
9.	Transportation and Storage .....	22
10.	Troubleshooting .....	24
11.	Specifications .....	25
12.	Parts Diagrams .....	27
13.	Warranty .....	33

# I . General Safeguards

## Safety Precautions

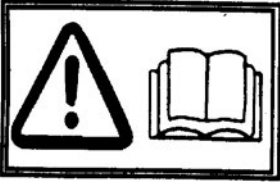

Please read this operation manual to have a thorough understanding of the content there before use the product. Failure to do so may lead to personal injury or mechanical damage.

Before starting the engine, perform inspections according to the procedures described on pre-operation inspections to avoid accidents and damage to your machine.

For safety, never attempt using this GEP (gasoline engine powered) water pump to deliver inflammable or corrosive liquids (such as gasoline and acids). Likewise, corrosive mediums, seawater, chemical solvents, alkaline liquids (such as used gasoline, liquor and honey) should be avoided.

Place the water pump on a solid, level position surface to avoid tilting or turnover that may give rise to spilling of fuel.

To prevent fire hazards, keep the pump well ventilated during operation and maintain a distance of at least 1 meter between the machine and the wall or other machines. Keep away from inflammable substances.

Do not allow children and pets to enter the working area as this may increase the chance of their getting burned by hot surfaces of the operating parts.

Know how to stop the water pump quickly how to operate the controls. Do not use the pump against the prescribed operating rules.

## **WARNING : Safety Precautions**

The gasoline fuel is highly inflammable and may explode under certain conditions.

Fuel with the engine shut down and in a well-ventilated environment. No smoking is allowed and no open fire or sparks allowed to exist in areas where fueling is carried out or the fuel is stored.

Do not allow the fuel to overflow the fuel tank. Be sure to recap the tank and tighten it after refueling.

When fueling, take care not to spill the gasoline about as the gasoline vapor may easily get ignited to cause a fire hazard. Be sure to remove the spilled gasoline as by wiping before starting the engine.

Do not run the engine indoors or in a poorly ventilated space as the exhaust gas produced by the running engine contains toxic carbon monoxide that may cause the loss of personal consciousness or even death.

## II. Location of Component Parts

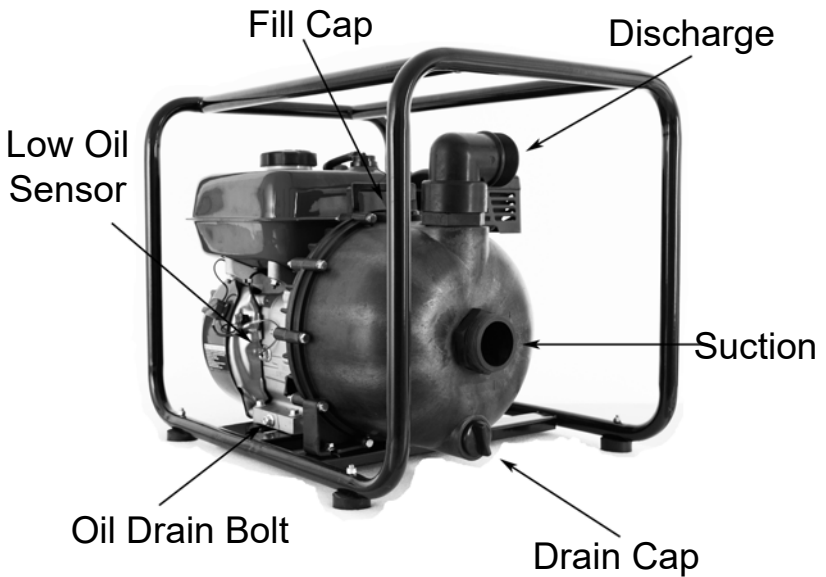
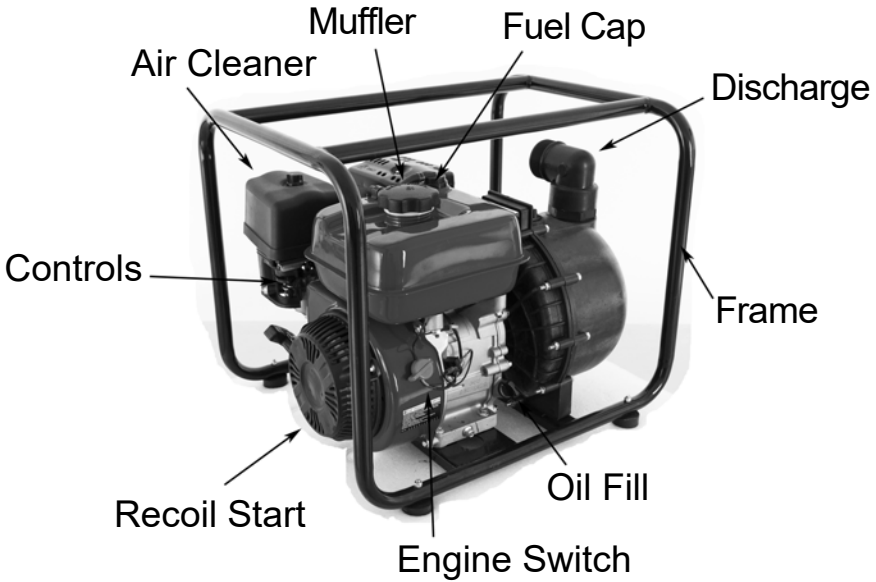

### III. Operation before Starting Up

#### 1. Connecting the water inlet

Connect the water inlet with a commercially available hose, connector and fastener clip. The inlet hose must be a continuous non-foldable structure with a length not more than required and should be placed near to the source of water so as to achieve the pump should be fitted to the end of the hose with the hose connector as shown in the figure below.

**CAUTION:** Before pumping water, attach the filter to the end of the hose to filter out foreign matters in the water, the presence of which may cause clogging and damage to the wane wheel.

**NOTE:** The hose connector and fastener clip should be securely fastened to prevent air leaks and reduction in suction power. A loose hose will reduce the pump performance and self-suction capacity.

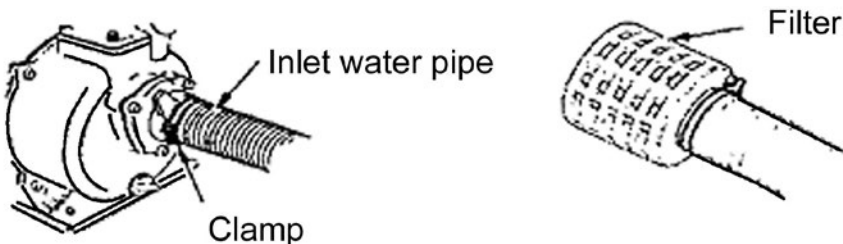

#### 2. Connecting the water outlet

Connect the water outlet with a commercially available hose, hose connector and fastener clip. Large diameter hoses are the most effective while small ones will increase the flow resistance and reduce the output power of the pump.

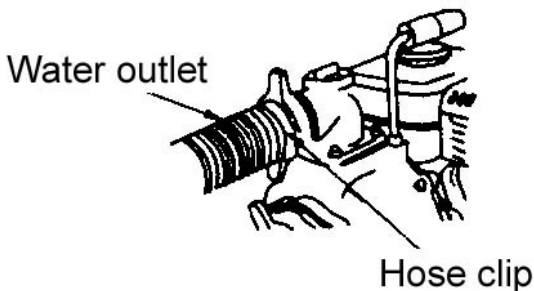

**NOTE:** \_\_\_\_\_

Be sure to the fastener clip is securely fastened to prevent the outlet hose from coming off under high water pressure.

### 3. Checking the oil level

**CAUTION:**

- The oil is one of the major factors affecting engine performance and life. Do not use dirty oil or vegetable oil.
- Be sure to check the oil level with the engine shut down and placed on a level surface.
- Please use the SE15-40, 4-stroke engine oil as recommended.
- Please use the type of oil with a proper viscosity according to the local average temperature.
- Oil shortage alarm system (OSAS) (installation position)  
The OSAS is designed to avoid damage of the engine due to the shortage of oil in the crankcase. The system will automatically shut down the engine just before the crankcase oil level drops down to the minimum line of safety (with the engine switch staying in the ON position).
- If the engine is shut down and cannot be started again, check the oil level before initiating further troubleshooting procedures. Remove the oil dipstick and wipe it dry. Insert the dipstick into the oil filler but not screw it in. Replenish the crankcase with the recommended type of oil until the oil level comes up to the upper most position of the refilled if the existing oil level is found too low.



**CAUTION:**

- Running the engine at a low oil level will cause damage to it.

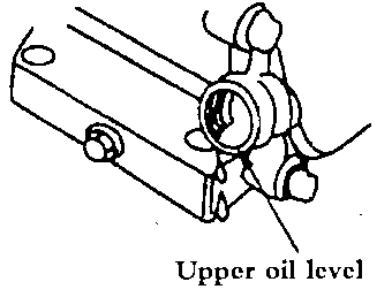
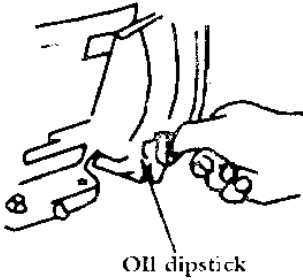

**4. Checking the fuel level**

Uncap the fuel tank and check the fuel level. Pouring gasoline if the fuel level is found too low.

Please use the type of gasoline recommended by the Dealer. Do not use a mixture of gasoline and oil or dirty gasoline to prevent dirt, dust or water from entering the fuel tank.

**CAUTION:**

- The gasoline fuel is highly inflammable and may explode under certain conditions.
- Do the fueling with the engine shut down and in a well-ventilated environment. No smoking is allowed and no open fire or sparks allowed to exist in areas where fueling is carried out or the fuel is stored.
- Do not allow the fuel to overflow the fuel tank. Be sure to recap the tank and tighten it after refueling.

- When fueling, take care not to spill the gasoline about as the gasoline vapor may easily get ignited to cause a fire hazard.
- Be sure to remove the spilled gasoline as by wiping before starting the engine.
- Avoid frequent or extensive exposure of the skin to gasoline or breathing in the gasoline vapor. Keep the gasoline out of the reach of children.
- Fuel tank capacity: 1.0 gallons (US. 3.6 liters)

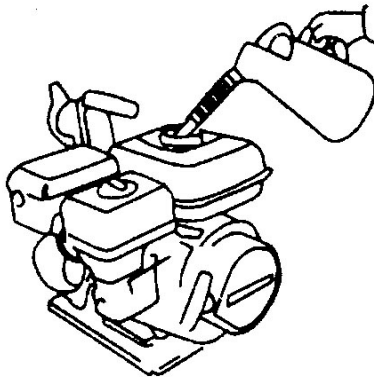

## 5. Checking the air cleaner filter element

Screw the wing nut and remove the washer and cleaner cover. Check the filter element to see if it is too dirty and clean it if necessary.

### CAUTION:

Do not run the engine without the air cleaner as this may quicken engine wear if dirt or dust is sucked into the engine through the carburetor.

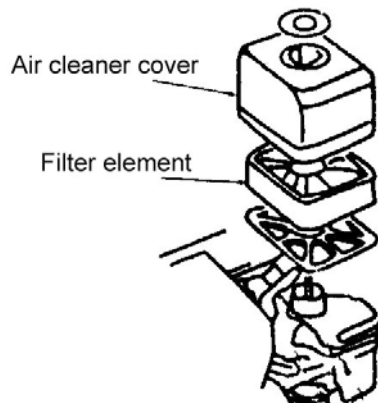

## 6. Checking and filling the pump with cooling water

The pump must be filled with water before it is put to operation. **CAUTION:**

- Do not attempt running the pump without cooling water or the pump will get overheated. Extensive running without cooling water may also damage the air tightness of the pump. If the pump is found running dry, stop the engine and pouring in water when it cools down.

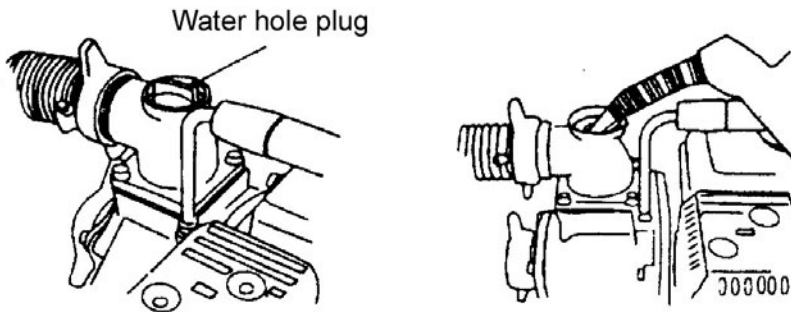

## IV. Starting engine

1. Turn on the fuel tap (by setting it to the ON position).
2. Close the choke.

### NOTE:

- The choke is not required when starting the engine warm or the ambient temperature is rather high, (i.e. keep the choke open when starting the engine).

3. Set the engine switch to the ON position.

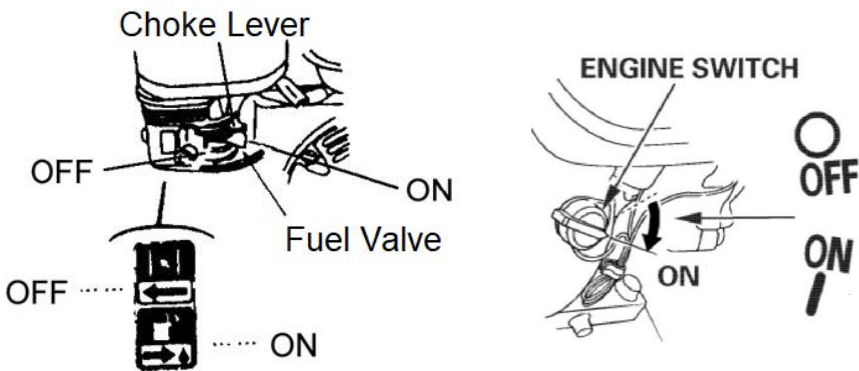

4. Turn the throttle control lever slowly to the left.

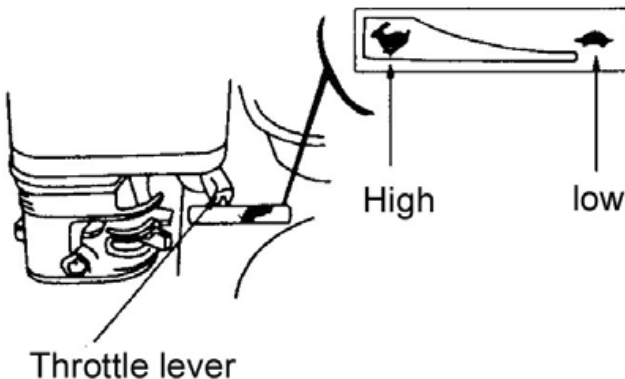

5. Gently pull up the starter lever until a resistance is felt and then quickly pull it up.

**CAUTION:**

•Do not allow the starter lever to retract quickly into the engine. Let it go back gently to avoid damaging the starter.

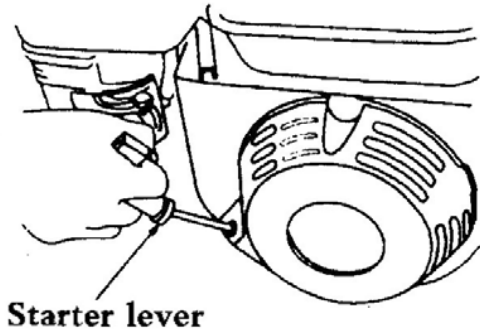

## V. Use in High Altitude

### Operation in High Altitude

In highland areas (with a high ASL elevation), the air-fuel mixture produced by a standard carburetor will be too thick and result in a reduced engine performance and soared fuel consumption. For operation in highland areas, the engine performance may be increased by using a smaller diameter carburetor nozzle and readjusting the carburetor idle speed. If the water pump is frequently used in areas with a ASL elevation of more than 1800 meters (6000 feet), ask the local dealer to replace or readjust the carburetor beforehand. Even if the engine is fitted with a carburetor nozzle of an appropriate size, the engine power will still go down by about 3.5% each time when the ASL elevation goes up by 305 meters (1000 feet). If no replacement or readjustment is ever made of the carburetor, the highland effect of the engine output power will be even more obvious.

## CAUTION:

- Using the water pump in areas where the ASL elevation is lower than suitable for the carburetor nozzle will lead to a decreased engine performance and overheating of the engine and even cause serious damage to the engine due to an extremely thin air-fuel mixture.

## VI. Operation of the Water Pump

1. Gradually open the choke after the engine warms up.
2. Set the throttle to the predetermined RPM.

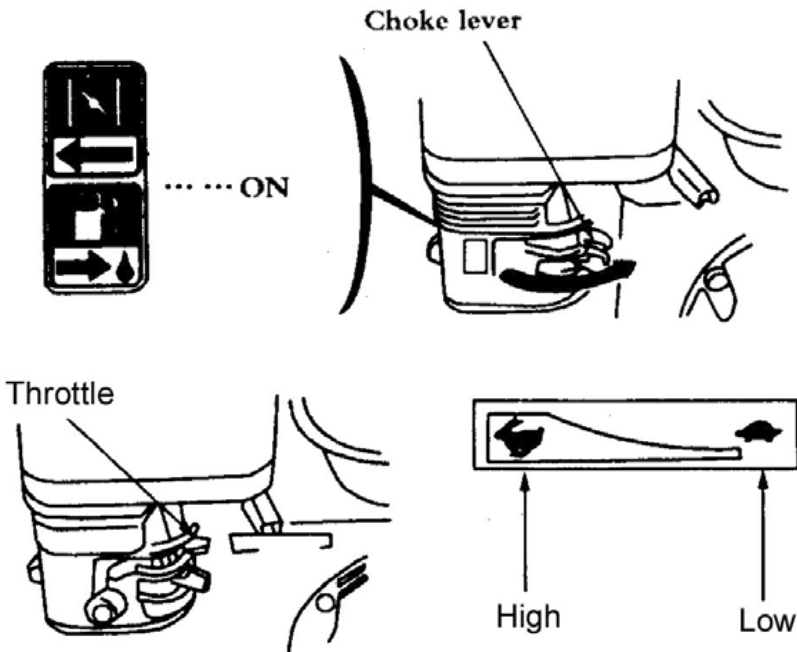

## VII. Shutting Down the Engine

1. Set the throttle control lever to the right end.
2. Set the engine switch to the OFF position.
3. Turn off the fuel tap (by setting to the OFF position).

### NOTE:

- To shut down the engine in an emergency, simply set the engine switch to the OFF position.

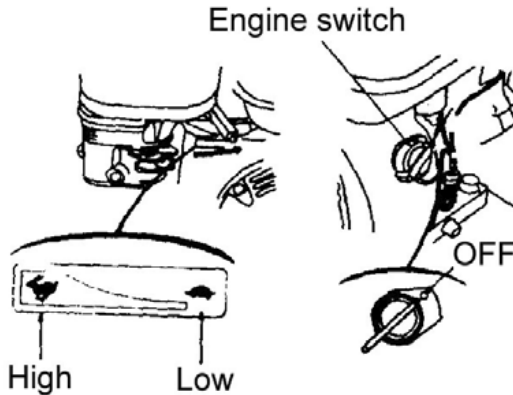

## VIII. Maintenance

Periodic inspections and fine-tuning are simply indispensable to keep the water pump working with high performance and regular maintenance may also lengthen the pump life. Supplied in the table on the next page are intervals at which the schedules maintenance jobs are to be done.

### WARNING:

- Before any maintenance attempt, be sure to shut down the engine. If the maintenance job has to be done with the engine at work, it should take place in a well-ventilated space as the exhaust gas contains toxic carbon monoxide that causes the loss of personal consciousness or even death.

## CAUTION:

- In cases when the pump is used to suck up seawater, be sure to flush it with fresh water immediately after use to minimize corrosion and remove deposits.
- Always use the original parts and relevant tools supplied with the machine to carry out maintenance. Failure to do this may cause damage to the pump.

## NOTE:

- (1) Inspection and maintenance should take place more frequently if the pump is used in a dirty environment.

### Table of Maintenance Schedules

Item \ Normal maintenance period	Each time	Per month or 20 hours	Per month or 50 hours	Per month or 100 hours	Per month or 300 hours
Check engine oil level	○				
Replace engine oil		○		○	
Air cleaner check	○				
Air cleaner for clean					
Spark plug			○		○*
Fuel supply	Replace per every two years				
Impeller					○*
Pump case cover					○*
Water inlet					○*



## 1. Replacing the engine oil

Oil drains easily and quickly while the engine is warm.

1. Remove the oil dipstick and drain bolt to let out the oil.
2. Screw the drain bolt back in place and tighten it.
3. Pour in clean oil until the desired level is reached.

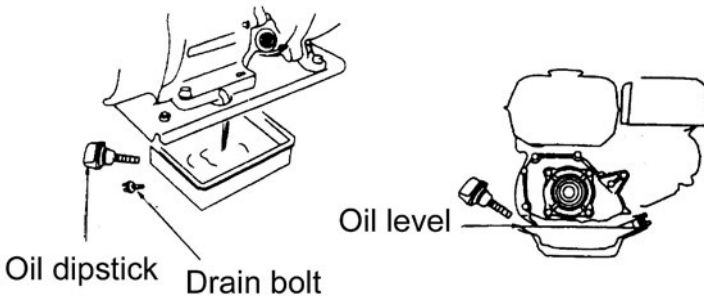

Oil capacity: 0.6 liters (20 oz)

Clean your hands with soap if stained with the engine oil. **NOTE:** Be sure to keep the environment clean when disposing used engine oil. We suggest you collect the waste oil in a container to be sent to a waste disposal site or a recycling service center of spill it in the garbage or on the ground.

## 2. Maintaining the air cleaner

A dirty air cleaner will let less air into the carburetor. To prevent carburetor malfunctions, be sure to maintain the air cleaner periodically. More frequent maintenance of the air cleaner will be necessary if the pump is working in an extremely dirty environment.

**DO not** clean the air cleaner with a low ignition point solvent because catch fire or even explode under certain circumstances.

**CAUTION:** Do not use the water pump without an air cleaner. The dirt or dust if sucked into the engine may quicken engine wear.

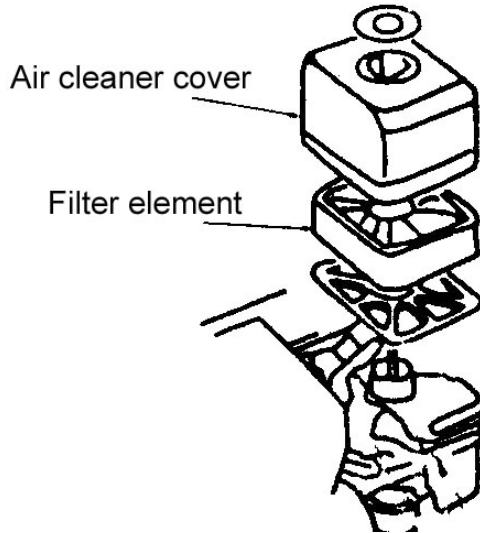

1) Unscrew the wing nut and remove the air cleaner cover and filter element.

2) Clean the filter element with a detergent solution inflammable or with a high ignition point and let it dry thoroughly after cleaning.

3) Immerse the filter element into clean oil and then squeeze out the excessive amount of oil.

4) Put the filter element as well as the air cleaner back in place.

### **3. Maintaining the spark plug**

The recommended type of spark plug is NHSP LD P6RTC. To ensure normal operation of the engine, the spark plug should have a correct gap and should remain free of carbon deposits.

1) Remove the plug cap.

\*The muffler may be very hot if the engine is still running. Take care not to touch the muffler.

2) Check the spark plug visually. Discard the spark plug if it is

obviously worn out or the insulation ring on it is broken or cracked. Clean the spark plug with a brush when put it back in place.

3) Check the plug gap with a feeler gauge. Vary the gap by moving the side electrode. Normal plug gap: 0.70~0.80mm

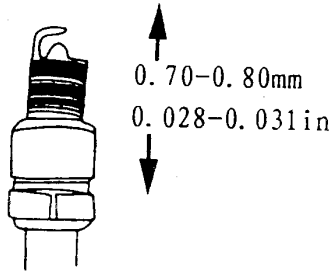

4) Check the plug O-ring for normal condition. Screw it in with the plug wrench to protect the plug thread.

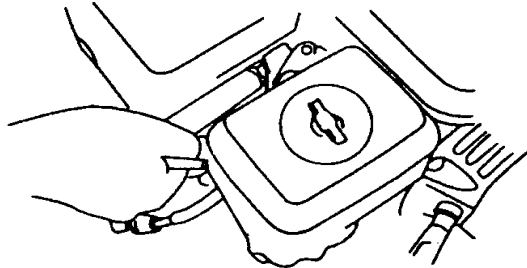

**NOTE:**

- In the case of screwing in a new spark plug, tighten it by an additional 1/2 screw turn after the plug reaches and pushes on the O-ring, while in the case of a used spark plug, an additional 1/2~1/4 screw turn is necessary.

**CAUTION:**

- Make sure the spark plug is properly tightened. Improper tightening may cause the engine to be overheated or damaged. Never use spark plugs with an incorrect thermal value range.

## IX. Transportation and Storage

### CAUTION:

- To avoid causing a fire hazard, let the engine cool down before transportation or indoor storage of the pump.
- Before transporting the pump, set the fuel tap to the OFF position and place the pump body in a level position to prevent the fuel from spilling out. The spilled gasoline or the gasoline vapor may get ignited.
- Note and do the following before storing pump for an extended period of time: make sure the storage area is free of moisture or dust.
- Clean the inside of the pump. The pump may get clogged if it is used to suck up water containing such matter as earth, sand or heavy fragments.
- Before storing, clean the pump by sucking up clean water or otherwise the impeller may be damaged when the pump is put to use again. After cleaning, unscrew the water drain plug to drain off the water from inside the pump casing as much as possible. Then screw the drain plug back into place.

### 3) Drain off the fuel.

- a. Turn off the fuel tap (OFF position), unscrew the drain screw from the carburetor float chamber to drain off the fuel from inside the carburetor and collect the gasoline in a suitable container.
- b. Turn on the fuel tap (ON position) and collect the gasoline in a suitable container.

c. Screw the carburetor fuel drain screw back into place.

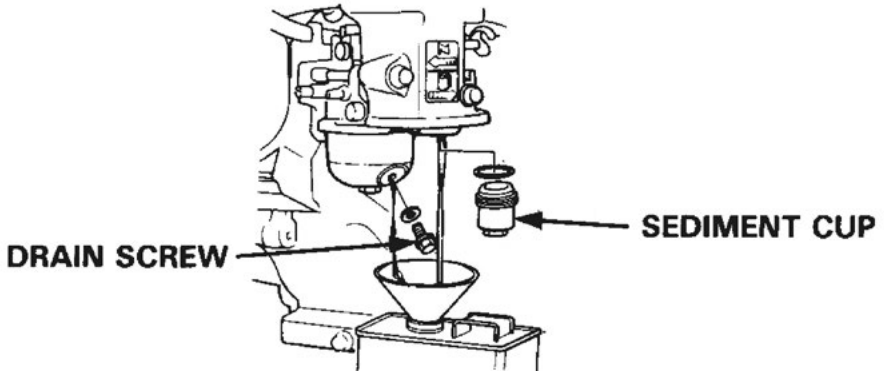

4) Replace the engine oil.

5) Screw off the spark plug, pour a spoonful of clean oil into the cylinder, turn the engine alternatively for several times to allow uniform distribution of oil, and then screw in the spark plug again.

6) Pull up the starter lever until a resistance is felt. Stop pull for a while and pull it up again until the triangle mark on the starter wheel gets into collimation with the screw hole in the starter (as shown the sketch below). In this position, both the inlet valve and outlet valve is closed to prevent corrosion inside the engine.

7) Cover up the pump to keep out dust.

## X. Troubleshooting

Engine unable to get started:

- 1) Is there enough fuel?
- 2) Is the fuel tap turned on?
- 3) Has the fuel reached the carburetor?  
Check by unscrewing the drain screw from under the carburetor with the fuel tap turned on.

### **WARNING:**

Should there be a spill of fuel, be sure to clean it before checking the spark plug and start the engine or otherwise the spilled fuel or fuel vapor may get ignited.

- 4) Is the engine switch set to the ON position?
- 5) Is there enough oil in the crankcase?
- 6) Is the spark plug generating sparks?
  - a. Uncap the spark plug, clear off the dirt from around the plug and remove the spark plug.
  - b. Fit the spark plug into the plug cap.
  - c. Turn on the engine with the side electrode and pull up the starter lever to see if there is sparks generated.
  - d. Ground the engine with the side electrode and pull up the starter lever to see if there is sparks generated.
  - e. Replace the spark plug if no spark is found.Start the engine as directed in the operation manual if sparks are generated.
- 7) If the engine still refuses to get started, send the pump to any of the authorized dealers.

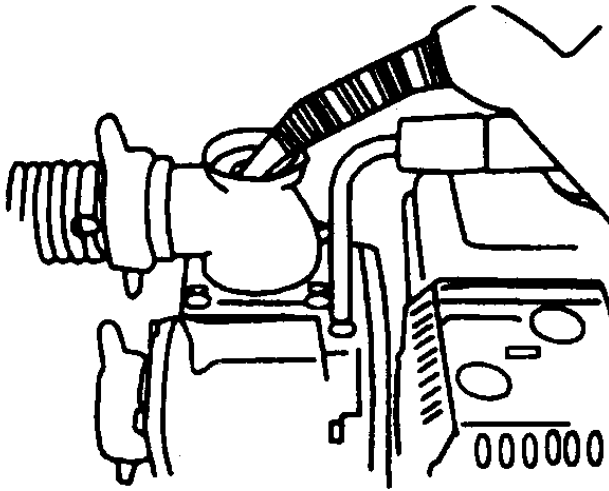

**The pump unable to suck up water:**

- 1) Is it filled with enough amount of water?
- 2) Is the filter clogged?
- 3) Is the hose fastener clip tightened?
- 4) Is the hose damaged?
- 5) Is the suction head too high?
- 6) If the pump still fails to work, send it to any of the authorized dealers.

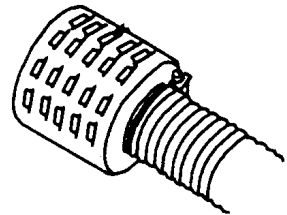
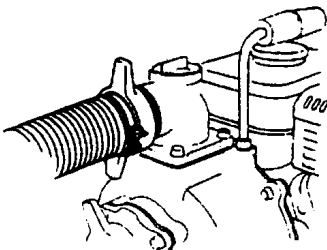

## XI. Specifications

<b>Pump Model</b>	<b>XP702CP</b>	<b>XP703CP</b>
<b>Engine Model</b>	DH212	DH212
<b>Rated Output Power</b>	4.3 kW @ 3,600 RPM	4.3 kW @ 3,600 RPM
<b>Engine CC</b>	212 cc	212 cc
<b>Fuel Capacity</b>	0.95 Gal (3.6L)	0.95 Gal (3.6L)
<b>Oil Capacity</b>	20 oz (0.6L)	20 oz (0.6L)
<b>Suction Port</b>	2" (50mm)	3" (80mm)
<b>Discharge Port</b>	2" (50mm)	3" (80mm)
<b>Max Delivery Lift</b>	98 ft. (30m)	65 ft (20m)
<b>Max Flow Rate</b>	132 GPM (30 m3/h)	255 GPM (58 m3/h)
<b>Suction Distance</b>	23 ft (7m)	23 ft (7m)
<b>RPM</b>	3600 RPM	3600 RPM
<b>Weight</b>	50.7 lbs. (23kg)	55.1 lbs (25kg)



# Wiring Diagram



# Engine Diagram

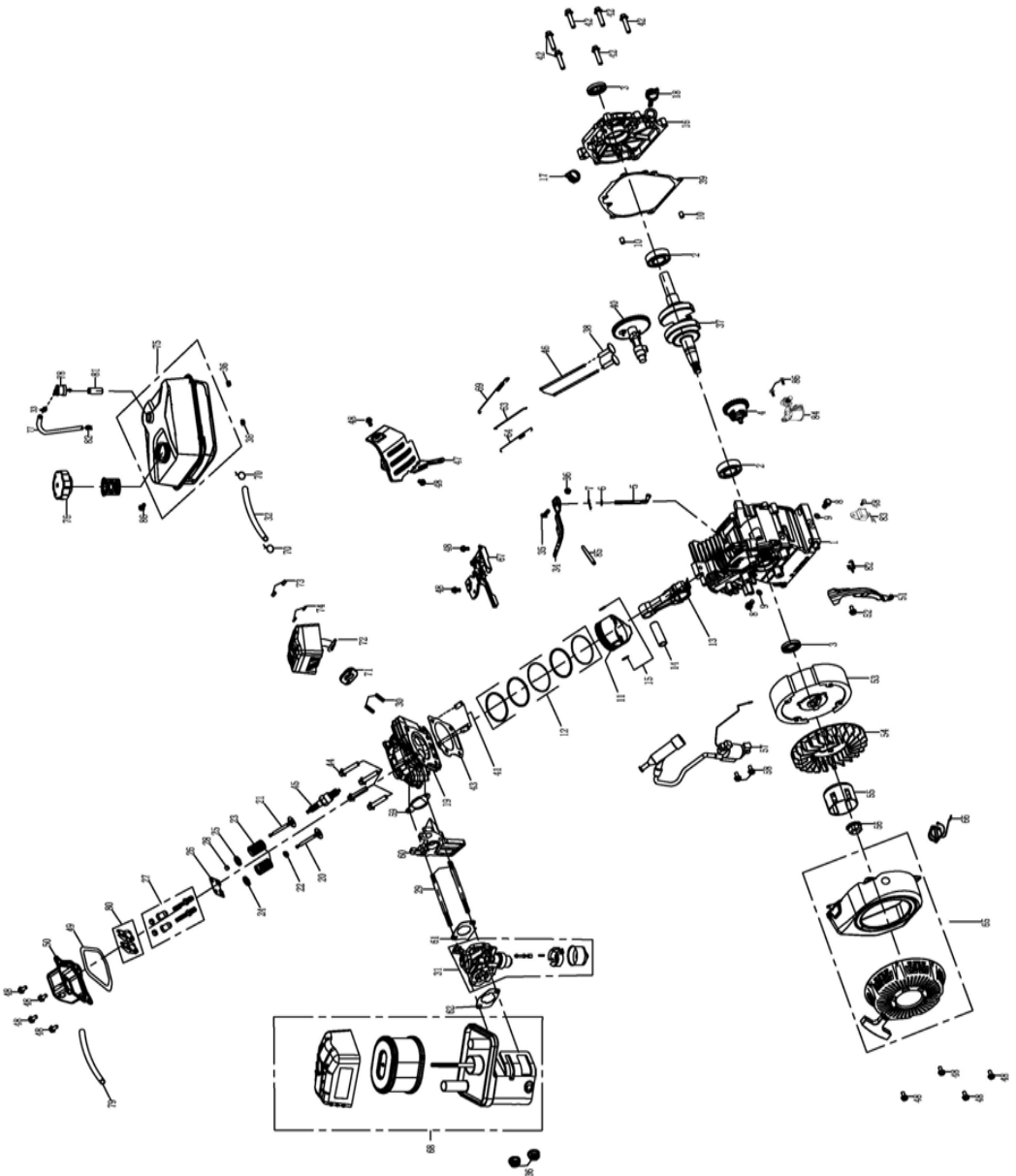

# Engine Parts List

#	Item #	Description	Qty
1	240210	CRANKCASE	1
2	93009	BALL BEARING	2
3	93507	OIL SEAL	2
4	244302	GOVERNOR ASSEMBLY	1
5	243901	SHAFT,GOVERNOR ARM	1
6	96804	WASHER,GOVERNOR ARM SHAFT	1
7	243902	PIN,LOCK	1
8	91816	BOLT, DRAIN PLUG	2
9	94007	WASHER,DRAIN PLUG	2
10	240901	DOWEL PIN,CASECOVER	2
11	241208	PISTON	1
12	241606	SCRAPER RING SET ,PISTON	1
13	241503	ROD ASSEMBLY., CONNECTING	1
14	245503	PIN, PISTON	1
15	241301	CLIP, PISTON	2
16	240104	COVER ASSEMBLY, CRANKCASE	1
17	241402	OIL PLUG	1
18	245602	DIPSTICK	1
19	241011	CYLINDER HEAD	1
20	241704	VALVE,IN	1
21	245904	VALVE EXHAUST	1
22	241805	RETURNER,INTAKE VALVE	1
23	246001	SPRING,VALVE	2
24	241801	SEAT, VALVE SPRING,IN	1
25	241802	SEAT, VALVE SPRING,EX	1
26	242202	PLATE,PUSH ROD GUIDE	1
27	91818	ROCKER ARM TIGHTENING BOLTS	2
28	241804	ROTATOR	1
29	91006	BOLT, STUD	2
30	91007	BOLT, STUD	2
31	242816	CARBURETOR ASSEMBLY	1
32	95405	FUEL LINE	1
33	94409	CLIP,FUEL LINE	1
34	244001	GOVERNOR ARM	1
35	91822	BOLT,GOVERNOR ARM	1
36	90016	NUT M6	5
37	240348	CRANKSHAFT ASSEMBLY	1
38	246102	LIFTER,VALVE	2
39	96041	PACKING,CASECOVER	1
40	242003	CAMSHAFT ASSEMBLY	1
41	240905	PIN, DOWEL	2
42	91347	BOLT M8X30	6
43	96044	GASKET,CYLINDER HEAD	1

#	Item #	Description	Qty
44	91359	BOLT M8X60	4
45	97108	SPARK PULG	1
46	241901	ROD,PUSH	2
47	240501	SHROUD	1
48	91325	BOLT M6X12	12
49	96045	PACKING,HEADCOVER	1
50	241107	COVER COMP,CYLINDER HEAD	1
51	245703	WIND SHIEL COMP.	1
52	91330	BOLT M6X20	1
53	240401	FLYWHEEL ASSEMBLY	1
54	244601	FAN,RECOIL STARTER	1
55	244502	PULLEY,STARTER	1
56	90003	NUT	1
57	97514	IGNITION COIL ASSY	1
58	91331	BOLT M6X25	2
59	96047	PACKING,INTAKE	1
60	242301	INSULATOR,CARBURETOR	1
61	96051	PACKING,CARBURETOR	1
62	94226	SPACER,CARBURETOR	1
63	242701	ROD,GOVERNOR	1
64	244207	SPRING,THROTTLE RETURN	1
65	244767-051	RECOIL STARTER ASSEMBLY	1
66	245205		1
67	244401	SHROUD ASSY,UPPER	1
68	242910	AIR CLEANER ASSEMBLY	1
69	244101	SPRING,GOVERNOR	1
70	94408	CLIP,FUEL LINE	2
71	96054	PACKING,EXHAUST	1
72	243707	MUFFLER COMP	1
73	90011	NUT M8	2
74	94206	SPRING WASHER	2
75	243103-051	FUEL TANK ASSEMBLY	1
76	915202	FUEL TANK CAP COMP	1
77	95303	CONNECTING PIPE	1
78	245405	MANUAL CHOKE ASSEMBLY	1
79	95603	TUBE,BREATHER	1
80	242101	ROCKER ARM	2
81	95903	VENTILATION TUBE PROTECTOR	1
82	94408	CLIP,FUEL LINE	1
83	245104	AMPLIFIER	1
84	245102	SWITCH ASSEMBLY,OIL LEVEL	1
85	599601	CLIP,WIRE HARNESS	1
86	91329	BOLT M6X16	2

# XP702CP Diagram

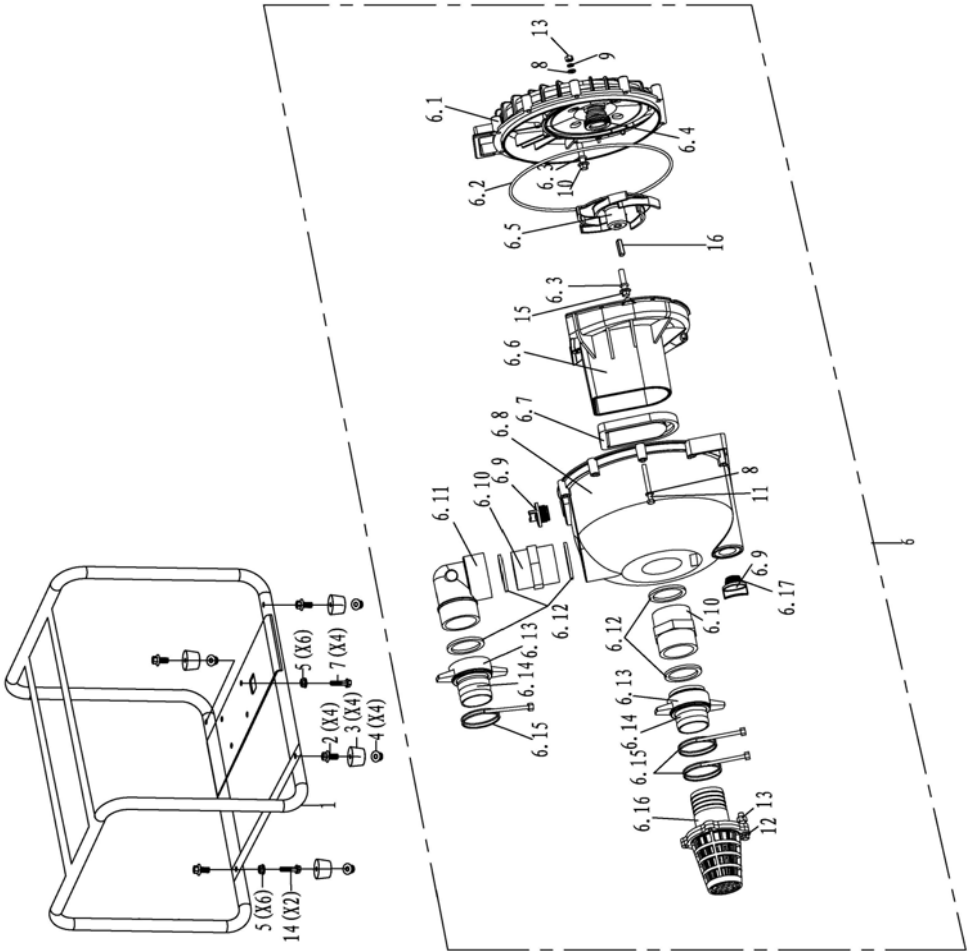

## XP702CP Parts List

#	Part #	Description	Qty
1	808220-010	FRAME	1
2	91335	BOLT M6X35	4
3	804004	RUBBER DAMPING BRACKET	4
4	90023	LOCK NUT M6	4
5	90018	NUT M8	6
6	801013	WATER PUMP ASSY	1
6.1	7238	Pump body seat	1
6.2	7241	PACKING RING,WATER PUMP	1
6.3	94050	PACKING RING,WATER PUMP	5
6.4	7235	PACKING RING,WATER PUMP	1
6.5	7242	FAN,RECOIL STARTER	1
6.6	7243	volute	1
6.7	7244	PACKING RING,WATER PUMP	1
6.8	7245	BODY,WATER PUMP	1
6.9	7220	Plug	2
6.10	7246	INLET	2
6.11	7247	OUTLET	1
6.12	7222	PACKING RING,WATER PUMP	5
6.13	7236	NUT	2
6.14	7237	SAM interface Pump	2
6.15	7226	CLIP	3
6.16	7344	FUEL FILTER	1
6.17	7248	PACKING RING,WATER PUMP	2
7	91348	BOLT	4
8	94260	FLAT WASHER $\Phi 6 \times \Phi 10 \times 1$	20
9	94259	SPLIT LOCK WASHER $\Phi 6$	10
10	91407	BOLT M8X35	4
11	91408	BOLT M6X65	10
12	7249	BOLT M6X20	2
13	90062	NUT M6	2
14	91345	BOLT	2
15	91217	BOLT	1
16	246509		1

# XP703CP Diagram

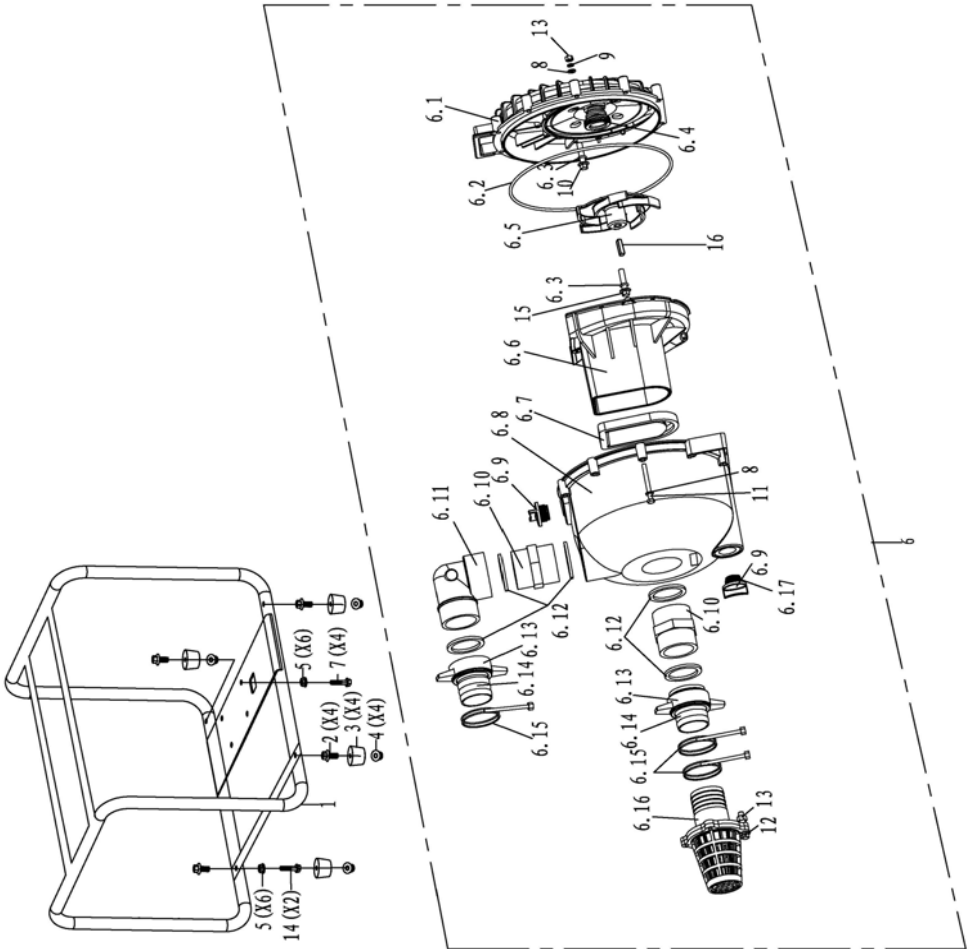

## XP703CP Parts List

#	Part #	Description	Qty
1	808419-010	FRAME	1
2	91335	BOLT M6X35	4
3	804004	RUBBER DAMPING BRACKET	4
4	90023	LOCK NUT M6	4
5	90018	NUT M8	6
6	801096	WATER PUMP ASSY	1
6.1	7238	Pump body seat	1
6.2	7241	PACKING RING,WATER PUMP	1
6.3	94050	PACKING RING,WATER PUMP	5
6.4	7235	PACKING RING,WATER PUMP	1
6.5	7336	FAN,RECOIL STARTER	1
6.6	7337	volute	1
6.7	7338	PACKING RING,WATER PUMP	1
6.8	7339	BODY,WATER PUMP	1
6.9	7220	Plug	2
6.10	7340	INLET	2
6.11	7341	OUTLET	1
6.12	7309	PACKING RING,WATER PUMP	5
6.13	7341	NUT	2
6.14	7342	SAM interface Pump	2
6.15	7343	CLIP	3
6.16	7344	FUEL FILTER	1
6.17	7219	PACKING RING,WATER PUMP	2
7	91348	BOLT	4
8	94260	FLAT WASHER $\Phi 6 \times \Phi 10 \times 1$	20
9	94259	SPLIT LOCK WASHER $\Phi 6$	10
10	91213	BOLT M8X35	4
11	91408	BOLT M6X65	10
12	7249	BOLT M6X20	2
13	90062	NUT M6	2
14	91345	BOLT	2
15	91217	BOLT	1
16	246509		1



## **WARRANTY**

### **3-year Warranty**

All DuroMax/DuroStar Power Equipment warrant the original purchasers to a 3-year Parts Warranty (Residential Use ONLY: Unusually heavy or commercial use is covered for a period of 1-year) in the event of failure due to defects in electrical or mechanical components. Freight on any items submitted for replacement or repair under the Warranty are the responsibility of the equipment owner. This warranty is non-transferable and only valid to the original purchaser.

### **Warranty Exclusions**

The DuroMax/DuroStar Power Equipment warranty does not cover repairs or returns when the fault is: Normal Wear and Tear, Installation Use or Maintenance Services, Cosmetic defects, Accessories, Failures due to acts of God or Natural Disasters, or problems related to/from aftermarket or non-OEM parts.

### **Warranty Limitations**

DuroMax/DuroStar Power Equipment does not claim or hold any obligation to loss of time, freight charges, use of product, or any incidental damages from the use of this product. THIS WARRANTY IS IN LIEU OF ALL OTHER WARRANTIES, EXPRESS OR IMPLIED.

## **U.S. EPA AND CALIFORNIA EMISSIONS CONTROL WARRANTY STATEMENT YOUR WARRANTY RIGHTS AND OBLIGATIONS**

The U.S. Environmental Protection Agency (EPA), California Air Resources Board, and Imperial Industrial Supply Co. LTD. / DuroMax Power Equipment are pleased to explain the emissions control system's warranty on your 2017 small off-road engine. In California, new equipment that use small off-engines must be designed, built, and equipped to meet the State's stringent anti-smog standards. DuroMax Power Equipment must warrant the emissions control system on your small off-road engine for the period listed below provided there has been no abuse, neglect, or improper maintenance of your equipment.

Your emissions control system may include parts such as: carburetors or the fuel injection system, ignition system, catalytic converters, fuel tanks, valves, filters, clamps, connectors, and other associated components. Also, included may be hoses, belts, connectors, sensors, and other emission-related assemblies.

Where a warrantable condition exists, DuroMax Power Equipment will repair your small off-road engine at no cost to you including diagnosis, parts, and labor.

### **MANUFACTURER'S WARRANTY COVERAGE:**

This emissions control system is warranted for two years. If any emissions-related part on your equipment is defective, the part will be repaired or replaced by DuroMax Power Equipment.

## **OWNER'S WARRANTY RESPONSIBILITIES:**

- As the small off-road engine owner, you are responsible for performance of the required maintenance listed in your owner's manual. DuroMax Power Equipment recommends that you retain all receipts covering maintenance on your small off-road engine, but DuroMax Power Equipment cannot deny warranty solely for the lack of receipts or your failure to ensure the performance of all scheduled maintenance.
- As the small off-road engine owner, you should however be aware that the DuroMax Power Equipment may deny you warranty coverage if your small off-road engine or a part has failed due to abuse, neglect, or improper maintenance or unapproved modifications.
- You are responsible for presenting your small off-road engine to a DuroMax Power Equipment distribution center or service center as soon as the problem exists. The warranty repairs should be completed in a reasonable amount of time, not to exceed 30 days.
- If you have any questions regarding your warranty coverage, contact us at 800-629-4329 or email [support@duromaxpowerequipment.com](mailto:support@duromaxpowerequipment.com).

## **DEFECTS WARRANTY REQUIREMENTS:**

The warranty period begins on the date the engine or equipment is delivered to an ultimate purchaser and extends for a period of Two Years.

## **GENERAL EMISSIONS WARRANTY COVERAGE:**

DuroMax Power Equipment warrants to the ultimate purchaser and each subsequent owner that the engine or equipment is:

1. Designed, built, and equipped to conform with all applicable regulations adopted by the Air Resources Board; and
2. Free from defects in materials and workmanship that causes the failure of a warranted part for a period of two years.

The warranty on emissions-related parts will be interpreted as follows:

1. Any warranted part that is not scheduled for replacement as required maintenance in the

Owner's Manual must be warranted for the warranty period stated above. If any such part fails during the period of warranty coverage, it must be repaired or replaced by the manufacturer according to Subsection (4) below. Any such part repaired or replaced under the warranty must be warranted for the remaining warranty period.

## WARRANTY (CONTINUED)

2. Any warranted part that is scheduled only for regular inspection in the Owner's Manual must be warranted for the warranty period stated above. A statement in such written instructions to the effect of "repair or replace as necessary" will not reduce the period of warranty coverage. Any such part repaired or replaced under warranty must be warranted for the remaining warranty period.
3. Any warranted part that is scheduled for replacement as required maintenance in the Owner's Manual must be warranted for the period prior to the first scheduled replacement point for that part. If the part fails prior to the first scheduled replacement, the part must be repaired or replaced by the engine manufacturer according to Subsection (4) below. Any such part repaired or replaced under warranty must be warranted for the remainder of the period prior to the first scheduled replacement point for the part.
4. Repair or replacement of any warranted part under the warranty must be performed at no charge to the owner at a warranty station.
5. Notwithstanding the provisions of Subsection (4) above, warranty services or repairs must be provided at all manufacturer distribution centers that are franchised to service the subject engines.
6. The owner must not be charged for diagnostic labor that leads to the determination that a warranted part is in fact defective, provided that such diagnostic work is performed at a warranty station.
7. The manufacturer is liable for damages to other engine components proximately caused by a failure under warranty of any warranted part.
8. Throughout the emissions warranty period stated above, the manufacturer must maintain a supply of warranted parts sufficient to meet the expected demand for such parts.
9. Any replacement part may be used in the performance of any warranty maintenance or repairs and must be provided without charge to the owner.
  - a. Such use will not reduce the warranty obligations of the manufacturer.
10. Add-on or modified parts that are not exempted by the Air Resources Board may not be used. The use of any nonexempt add-on or modified parts will be grounds for disallowing a warranty claim. The manufacturer will not be liable to warrant failures of warranted parts caused using a nonexempt add-on or modified part.
11. The manufacturer issuing the warranty shall provide any documents that describe that manufacturer's warranty procedures or policies within five working days of request by the Air Resources Board.

## Exhaust Emission Warranty Parts List.

1. Fuel Metering System
  - i. Carburetor and internal parts (and/or pressure regulator or fuel injection system).
  - ii. Air/fuel ratio feedback and control system.
  - iii. Cold start enrichment system.
2. Air Induction System
  - i. Controlled hot air intake system.
  - ii. Intake manifold.
3. Ignition System
  - i. Spark Plugs.
  - ii. Magneto or electronic ignition system.
  - iii. Spark advance/retard system.
4. Air Injection System
  - i. Air pump or pulse valve.
  - ii. Valves affecting distribution of flow.
  - iii. Distribution manifold.
5. Catalyst or Thermal Reactor System (i) Catalytic converter.
  - i. Thermal reactor.
  - ii. Exhaust manifold.
6. Particulate Controls
7. Traps, filters, precipitators, and any other device used to capture particulate emissions.
8. Electronic controls.
9. Vacuum, temperature, and time sensitive valves and switches.
10. Hoses, belts, connectors, and assemblies.
11. Evaporative Emission Warranty Part List
12. Fuel Tank\*
13. Fuel Cap
14. Fuel Line
15. Fuel Line Fittings
16. Clamps\*\*
17. Pressure Relief Valves\*\*
18. Control Valves\*\*
19. Control Solenoids\*\*
20. Electronic Controls\*\*
21. Vacuum Control Diaphragms\*\*
22. Control Cables\*\*
23. Control Linkages\*\*
24. Purge Valves
25. Vapor Hoses
26. Liquid/Vapor Separator
27. Carbon Canister
28. Canister Mounting Brackets
29. Carburetor Purge Port Connector

\*Note: The parts list for equipment less than or equal to 80 cc only includes the fuel tank. \*\*Note: As they relate to the evaporative emission control system.

DuroMax Power Equipment will furnish with each new engine written instructions for the maintenance and use of the engine by the owner.

## CUSTOMER SERVICE

Duromax Power Equipment is committed to ensuring that our products perform when they need to. Our generators are your lifeline in the event of an emergency. Should you have any problems, please contact our customer service department:

**DUROMAX POWER EQUIPMENT**  
**5798 Ontario Mills Parkway**  
**Ontario, CA 91764**

Customer Service: 800-629-3325  
Customer Service Hours: 8-5pm PST

Website: [www.duromaxpowerequipment.com](http://www.duromaxpowerequipment.com)  
Email: [customer\\_service@duromaxpowerequipment.com](mailto:customer_service@duromaxpowerequipment.com)





5798 Ontario Mills Parkway  
Ontario, CA 91764  
United States

800-629-3325