



OZCO BUILDING PRODUCTS

Product & Packaging Specs

4x4 Post Base (4x4-PB-IW)

Item #: 51707

ITEM NO.	QTY.	PART NUMBER	DESCRIPTION
1	1	56607-11	Assembly, 4x4 Stand Off
2	0.8	56621	1 1/2" Hex Cap Nut (HCN)
3	0.32	56625	OWT Timber Screw 1-3/4"
4	4	51707-15	Plate, 4x4 Side Compression

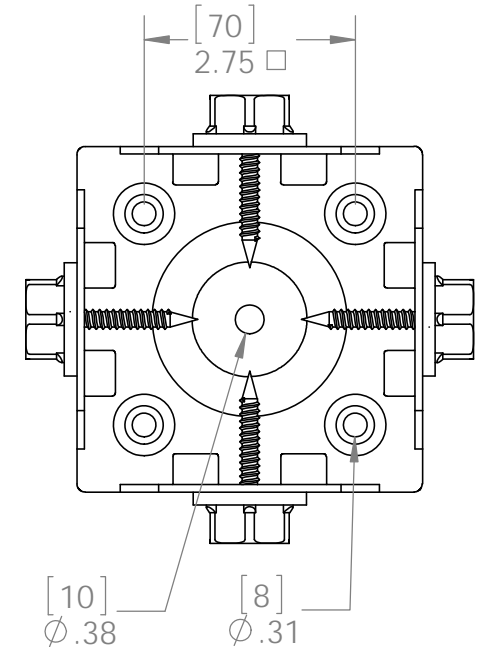
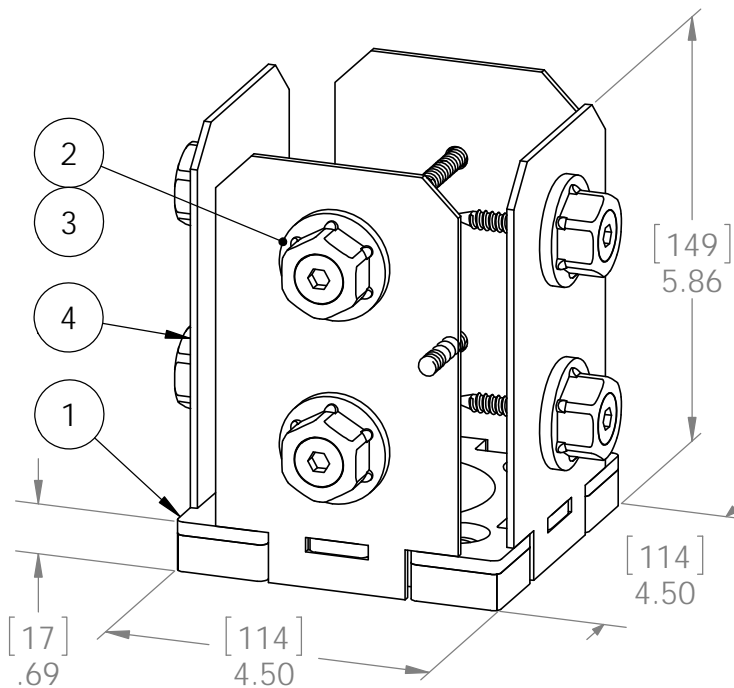
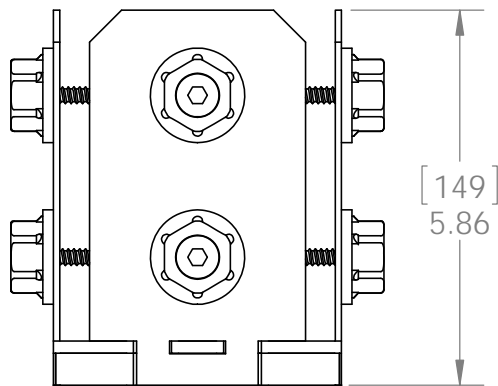
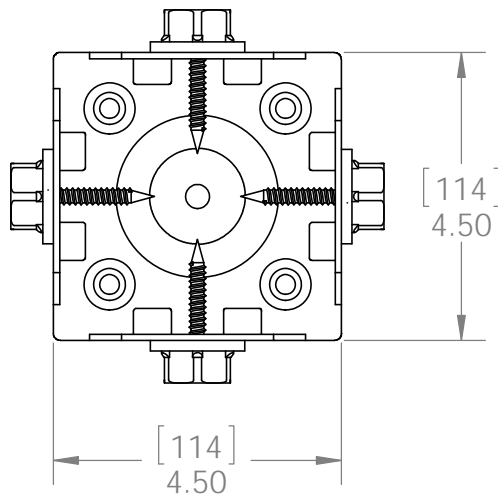

Weight: 6.84 LBS
 Scale: 1:2
 Last updated: 10/8/2015

51707

Product & Packaging Specs

4x4 Post Base (4x4-PB-IW)

Item #: 51707

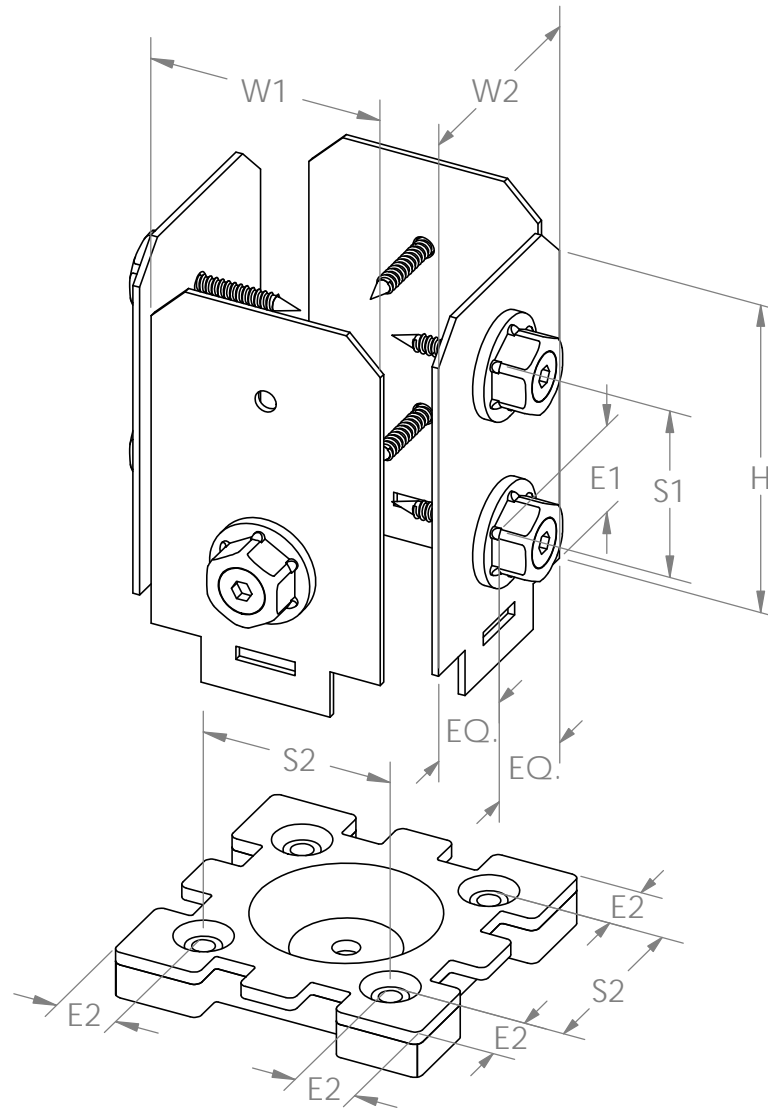

Weight: 6.84 LBS
Scale: 1:2
Last updated: 10/8/2015

51707

Product & Packaging Specs

4x4 Post Base (4x4-PB-IW)

Item #: Typical Installation & Basic Assembly

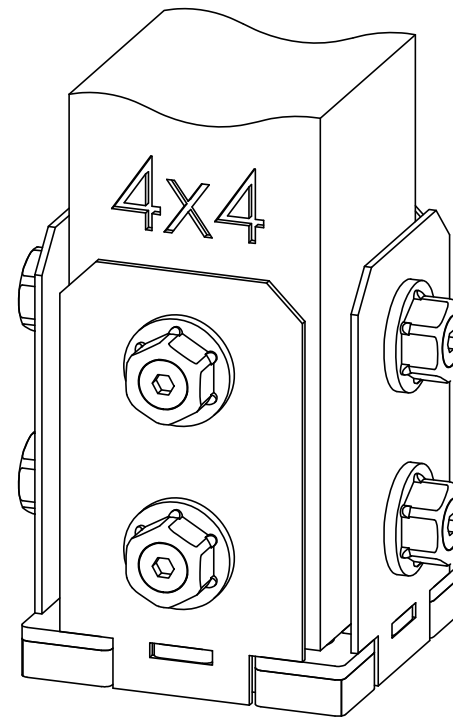

Weight: 6.84 LBS
Scale: 1:2
Last updated: 10/8/2015

51707

Product & Packaging Specs

4x4 Post Base (4x4-PB-IW)

Item #: Typical Installation & Basic Assembly

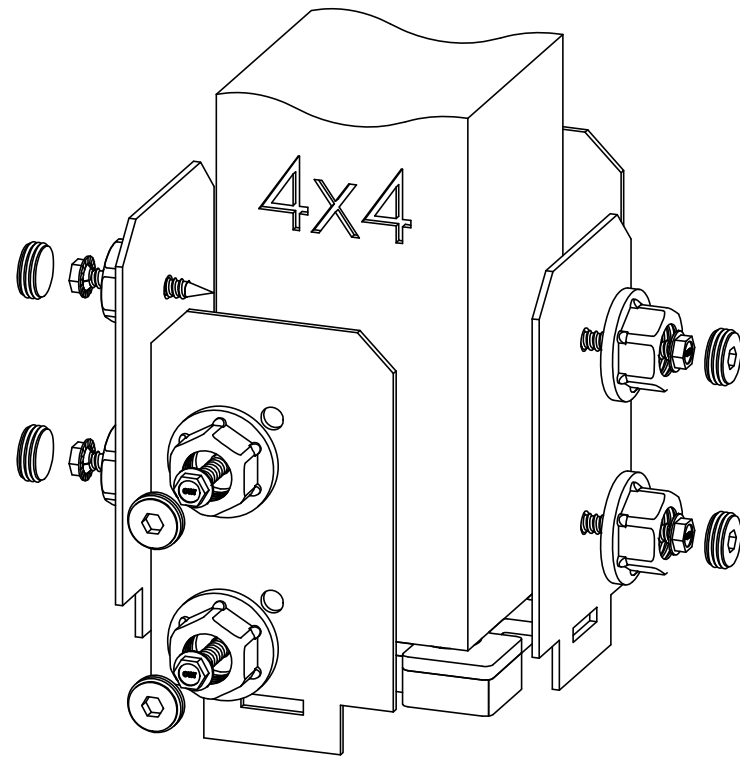
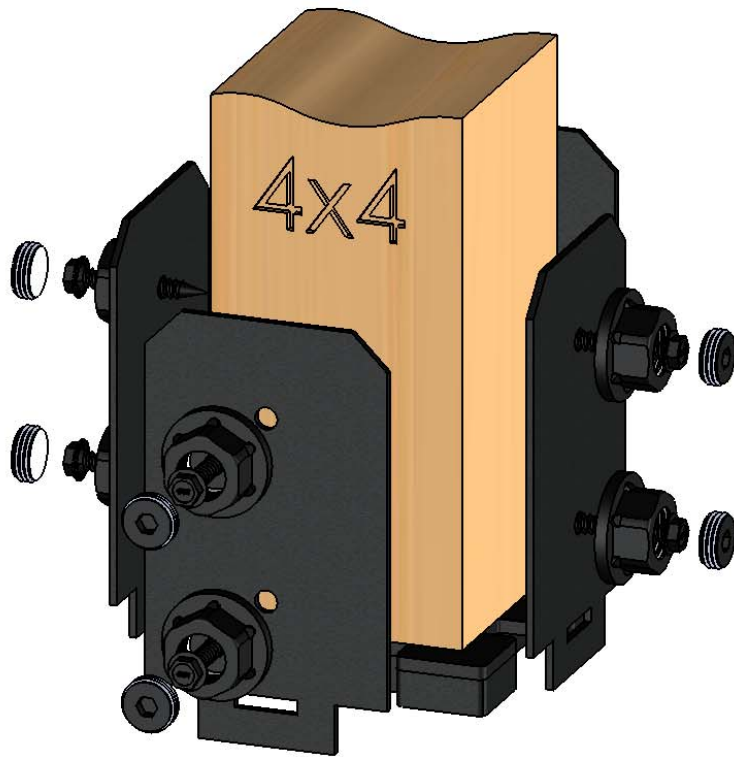

Weight: 6.84 LBS
Scale: 1:2
Last updated: 10/8/2015

51707

Product & Packaging Specs

Box, 51707

Item #: Box

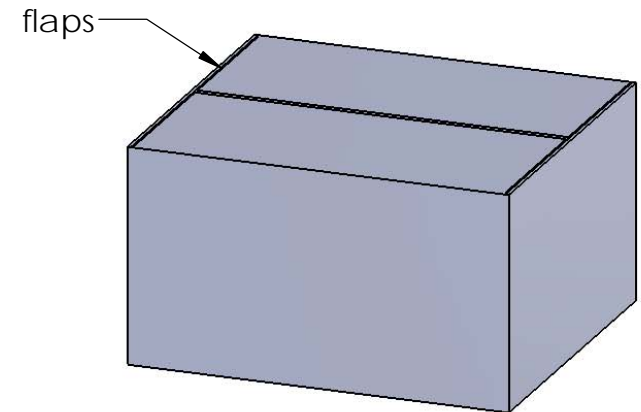
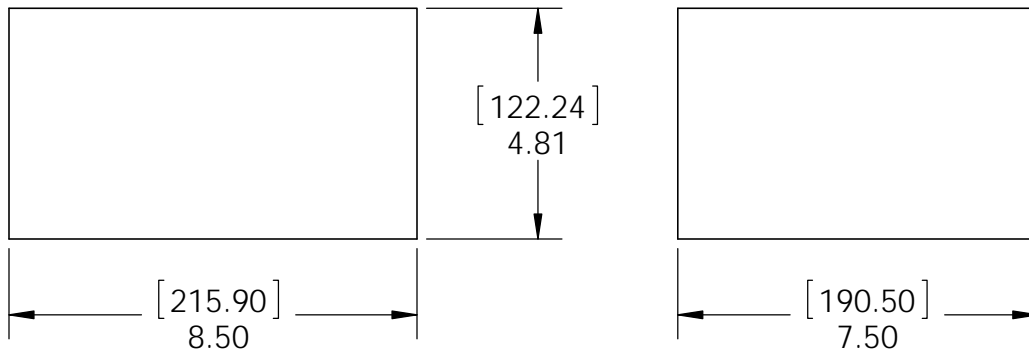

Material: Corrugated Paper
Finish: See artwork
Weight: 0.12 LBS
Scale: 1:4
Last updated: 10/8/2015

51707

Product & Packaging Specs

56607 Packing

Item #: Box packing

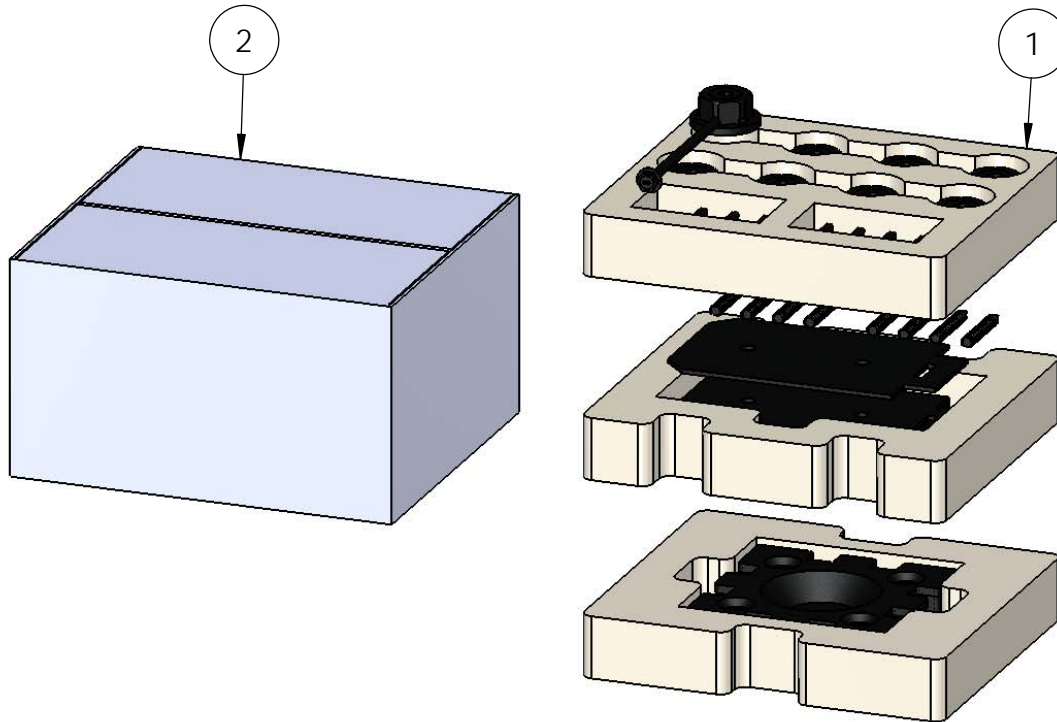

ITEM NO.	QTY.	PART NUMBER	DESCRIPTION
1	1	51707	4x4 Post Base (4x4-PB-IW)
2	1	Box, 51707	Box, 51707

Items not shown:

- installation instructions
- parts wrapped in packing foam sheet

Weight: 4.77 LBS
Scale: 1:4
Last updated: 10/8/2015

51707

Product & Packaging Specs

Case, 51707

Item #: Case

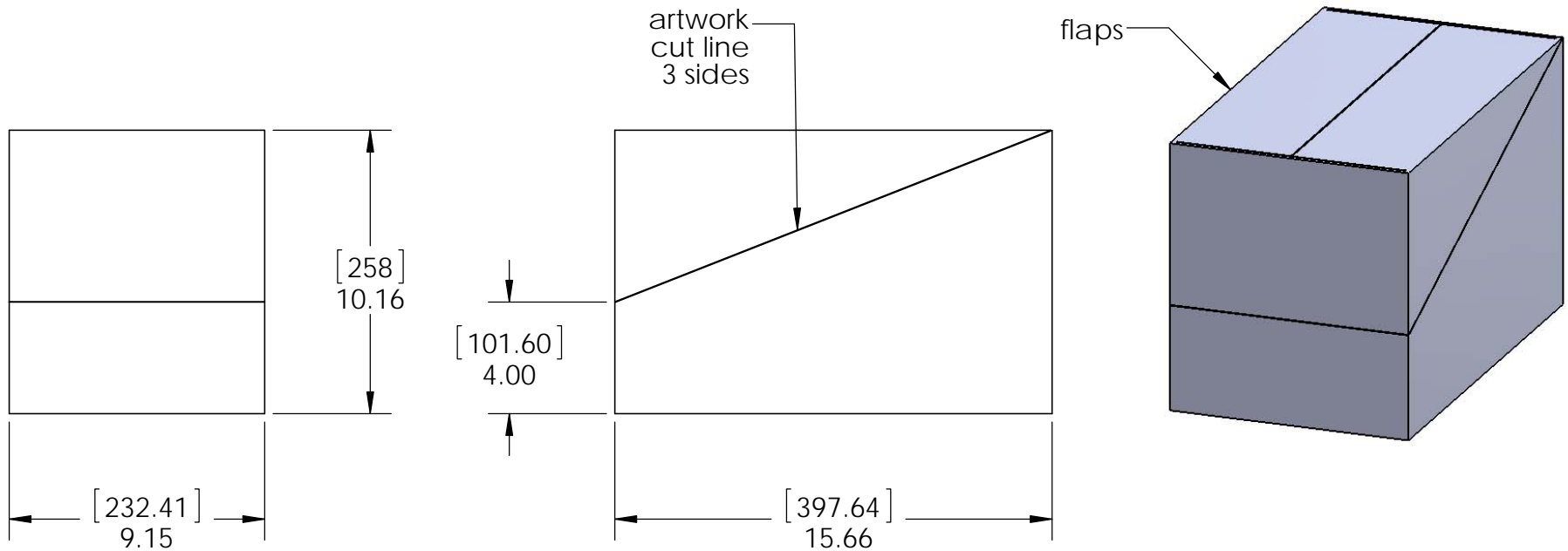

Material: Corrugated Paper
 Finish: See Artwork
 Weight: 0.86 LBS
 Scale: 1:6
 Last updated: 10/8/2015

51707

Product & Packaging Specs

56607 Packing

Item #: Case packing

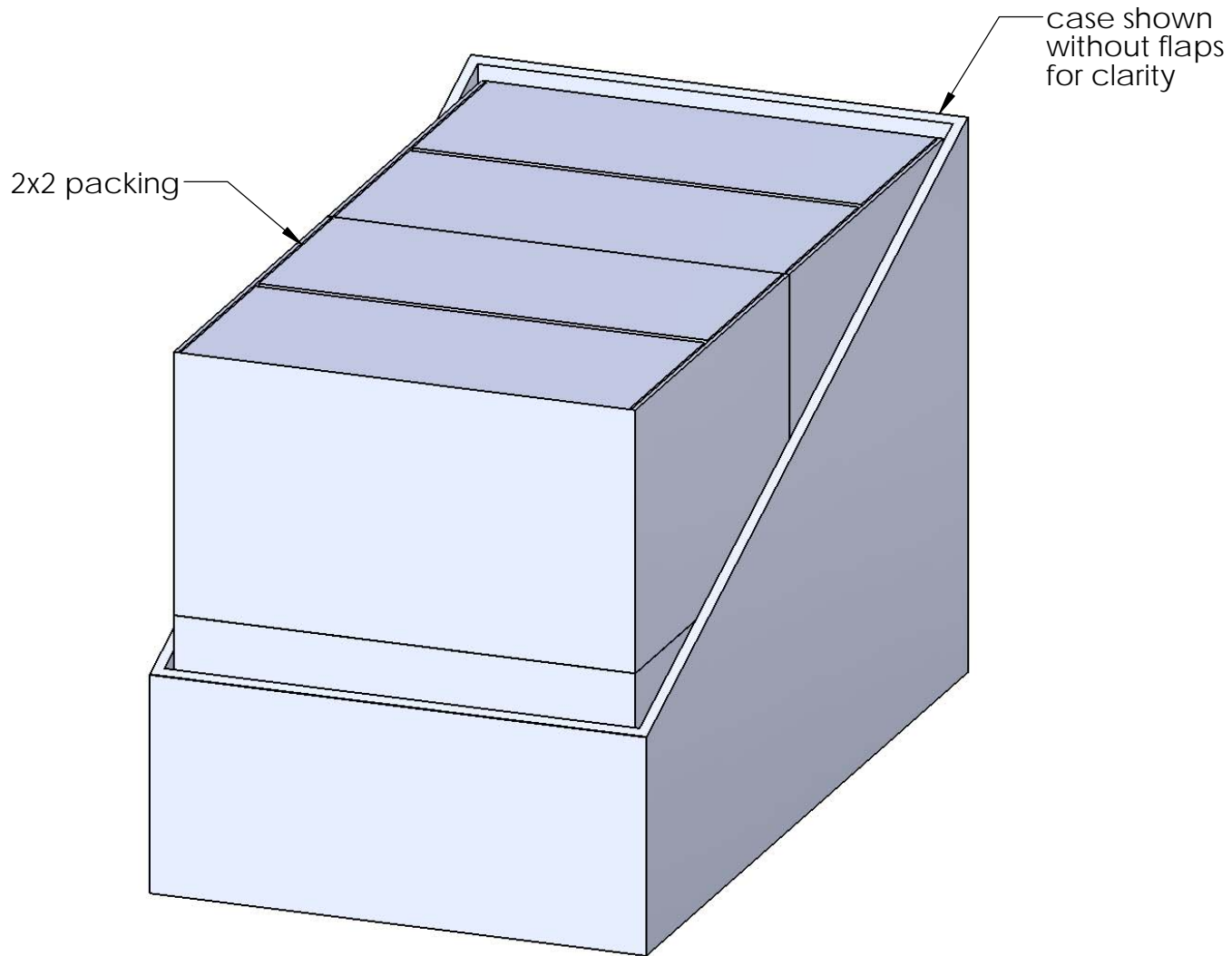

Weight: 18.14 LBS
Scale: 1:3
Last updated: 10/8/2015

51707

Product & Packaging Specs

56607 Packing

Item #: Pallet packing

ADD PALLET LABEL

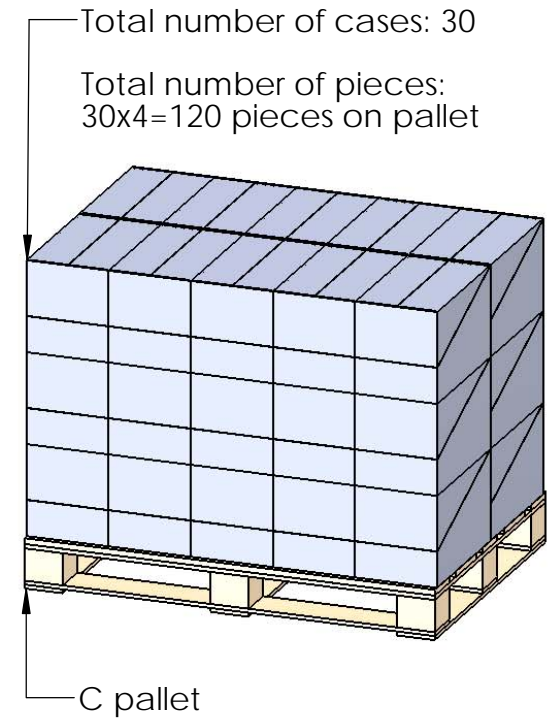
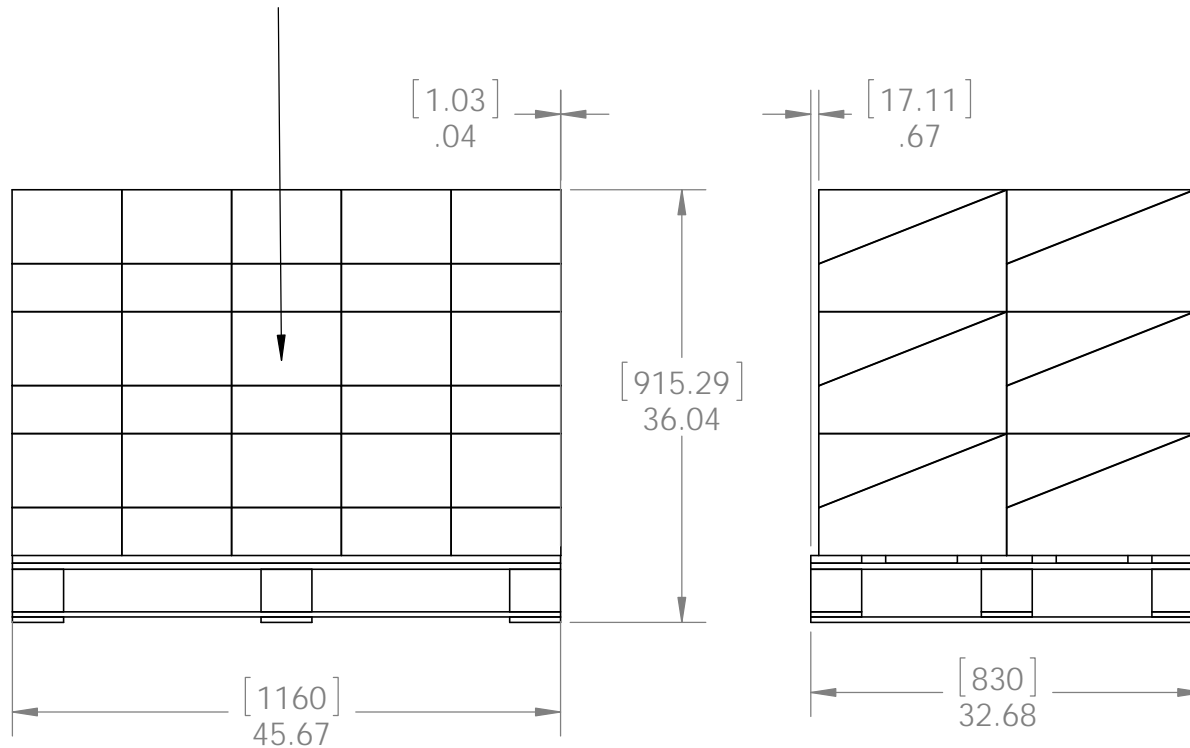

additional pallet packing instructions

- plywood on top layer
- strap to pallet
- clear wrap around boxes

Weight: 569 LBS
 Scale: 1:16
 Last updated: 10/8/2015