

WE Walker
Edison
furniture company

Item # :W48UBGL
Assembly Instructions

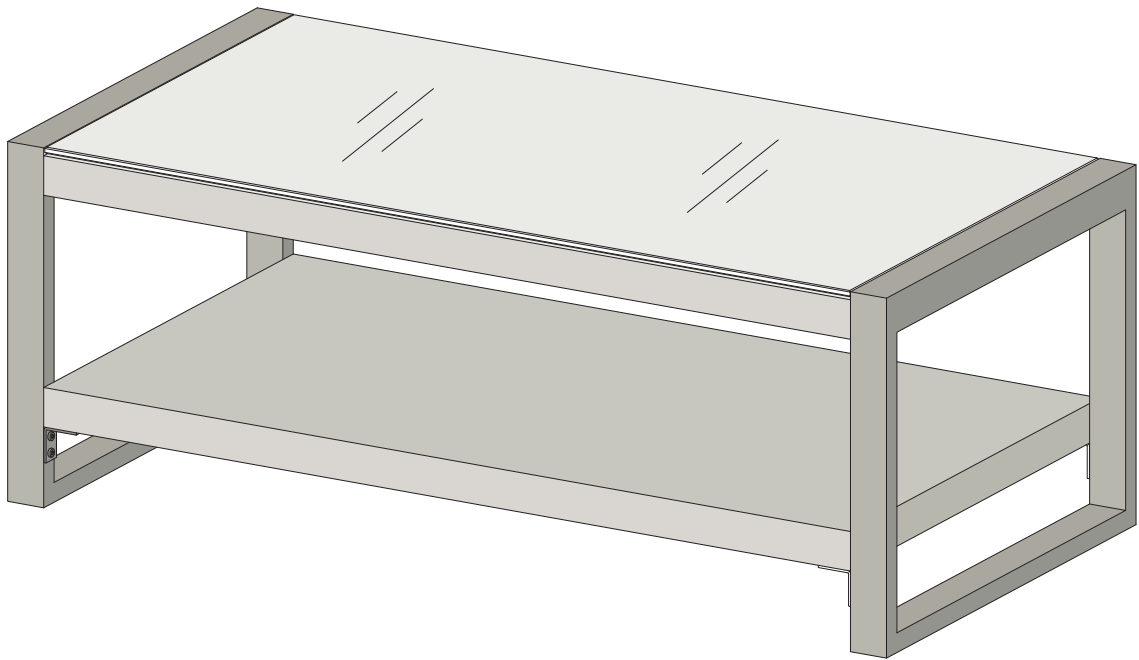



*To request missing, lost or broken parts,, or for any other customer service issues,
please visit our website at www.walkeredison.com or call us at 877-207-5906.*

Revised 07/2015

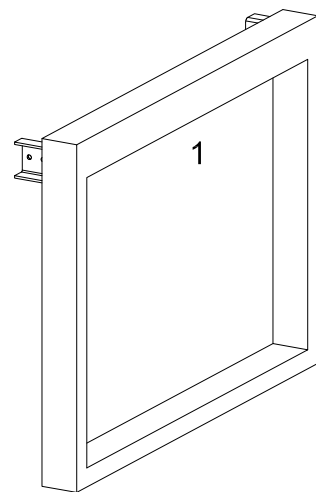
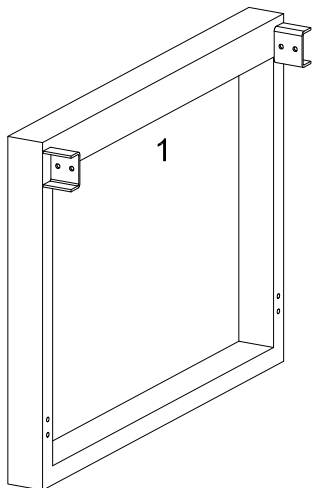
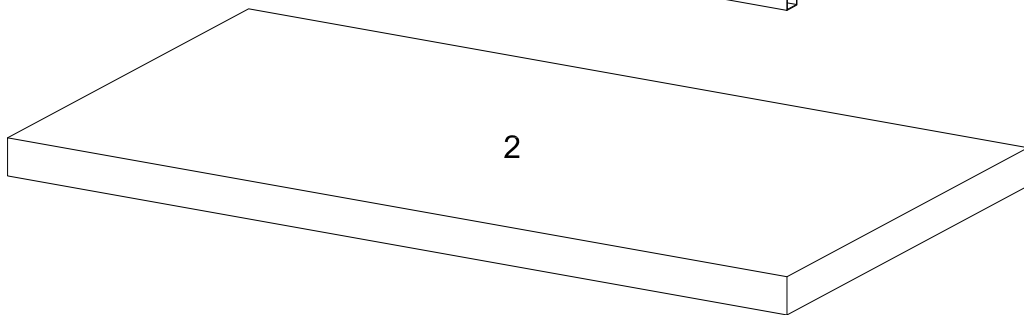
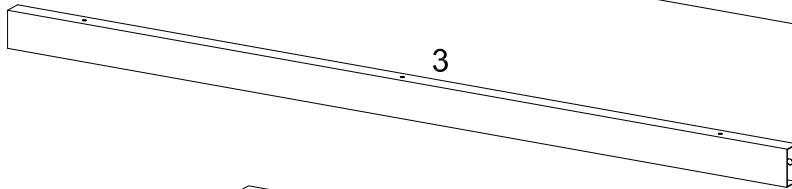
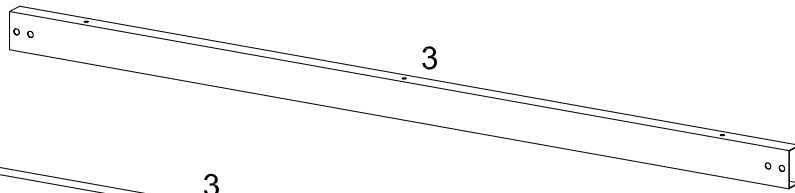
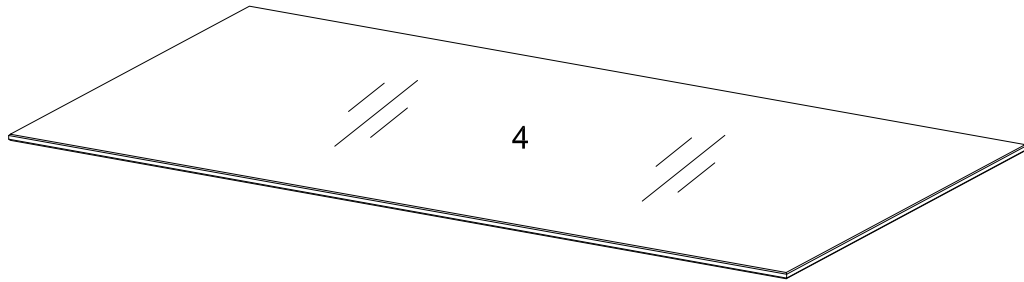
Parts List

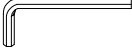

Hardware List

A		Ø6*12	Bolt	24 pcs
B			L Shape Bracket	4 pcs
C			Rubber suction cups	6 pcs
D		M4	Wrench	1 pc

*The hardware quantities listed above are required for proper assembly.
Some extra hardware may also have been included.*

Step 1

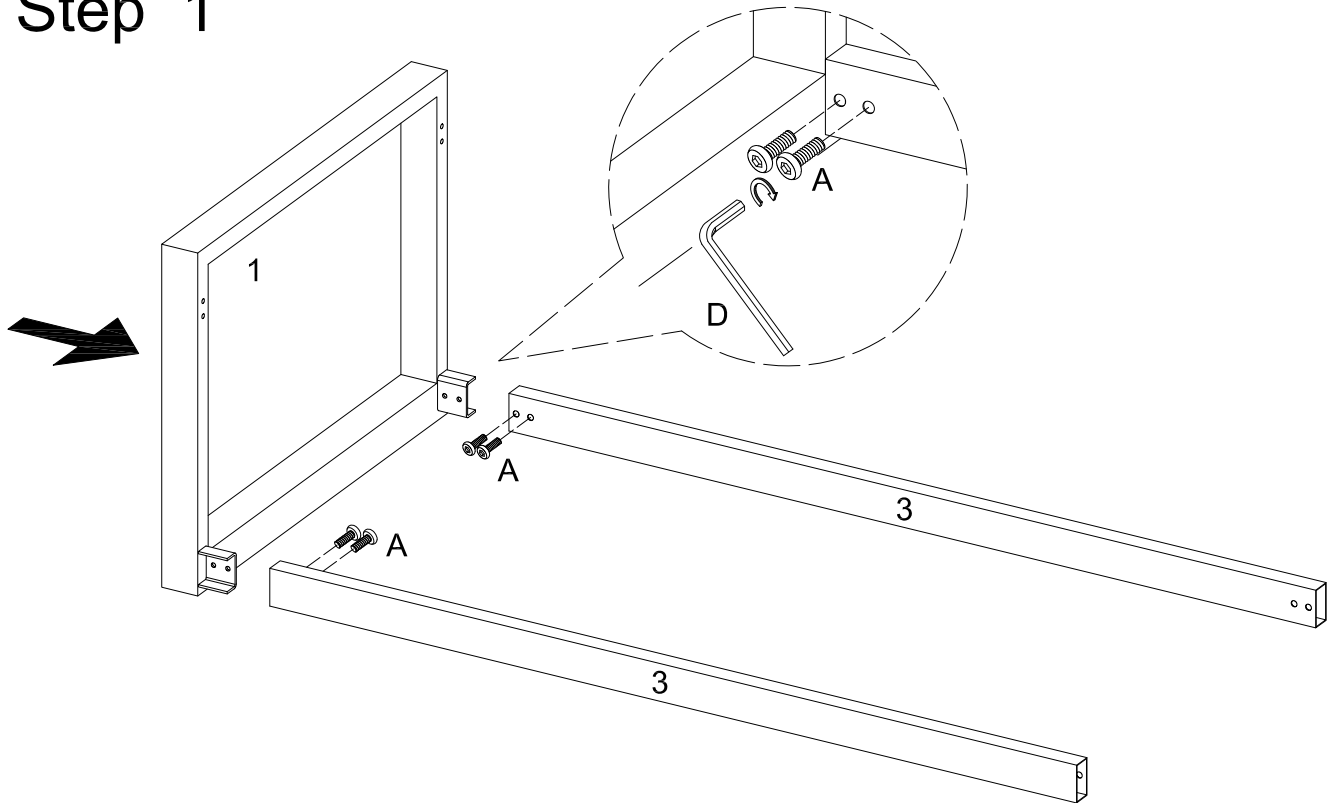

Use bolts (A), wrench (D) to secure the metal bars (3) to the side frame (1).

Step 2

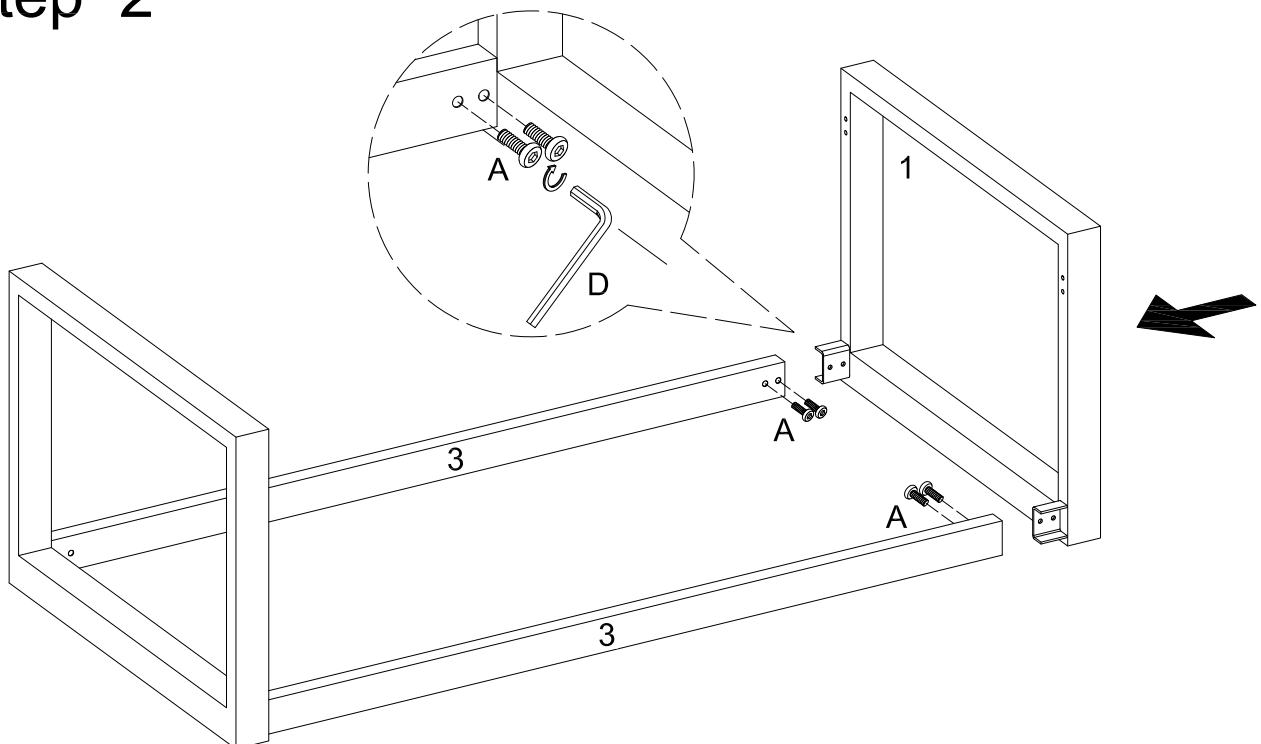

Use bolts (A), wrench (D) to secure the metal bars (3) to the other side frame (1).

Step 3

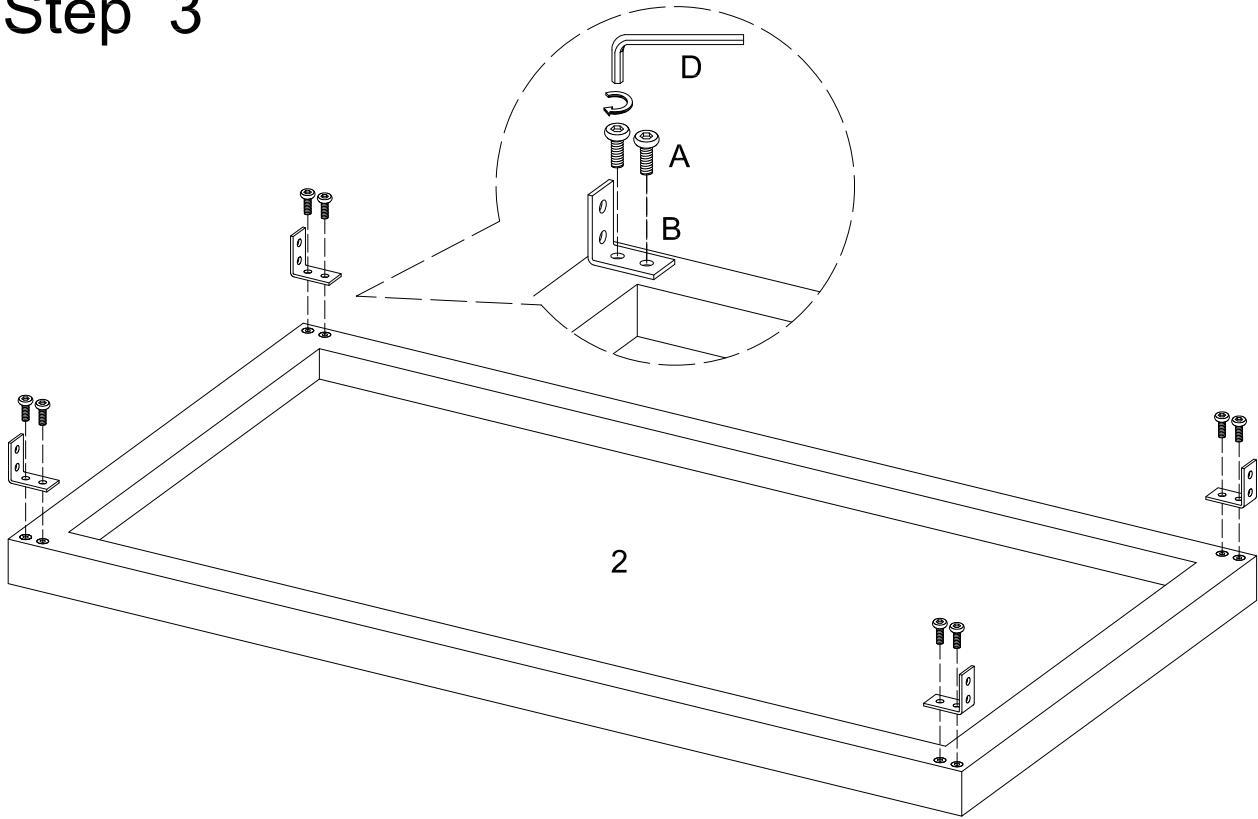

Use bolts (A), wrench (D) to secure the L bracket (B) to the bottom panel (2).

Step 4

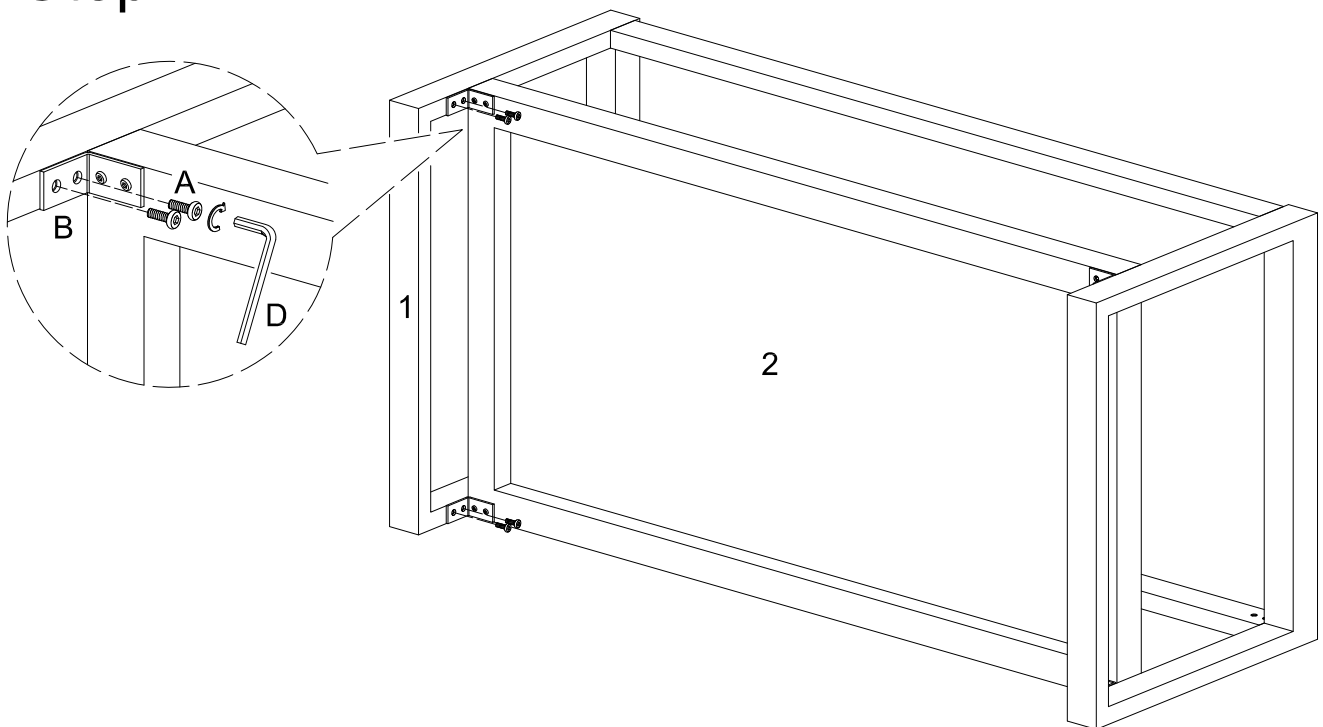

Use bolts (A), wrench (D) to secure the L shape bracket (B) to the side frame (1).

Step 5

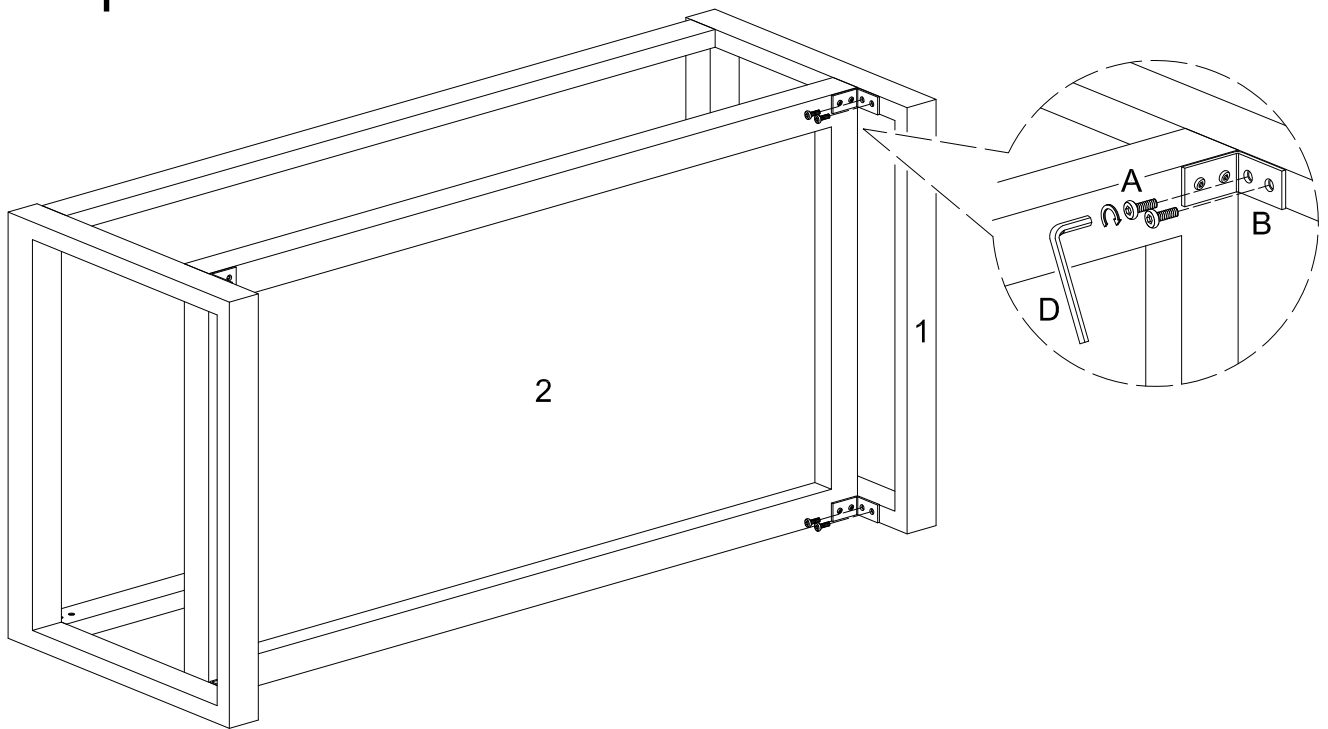

Repeat Step #4.

Step 6

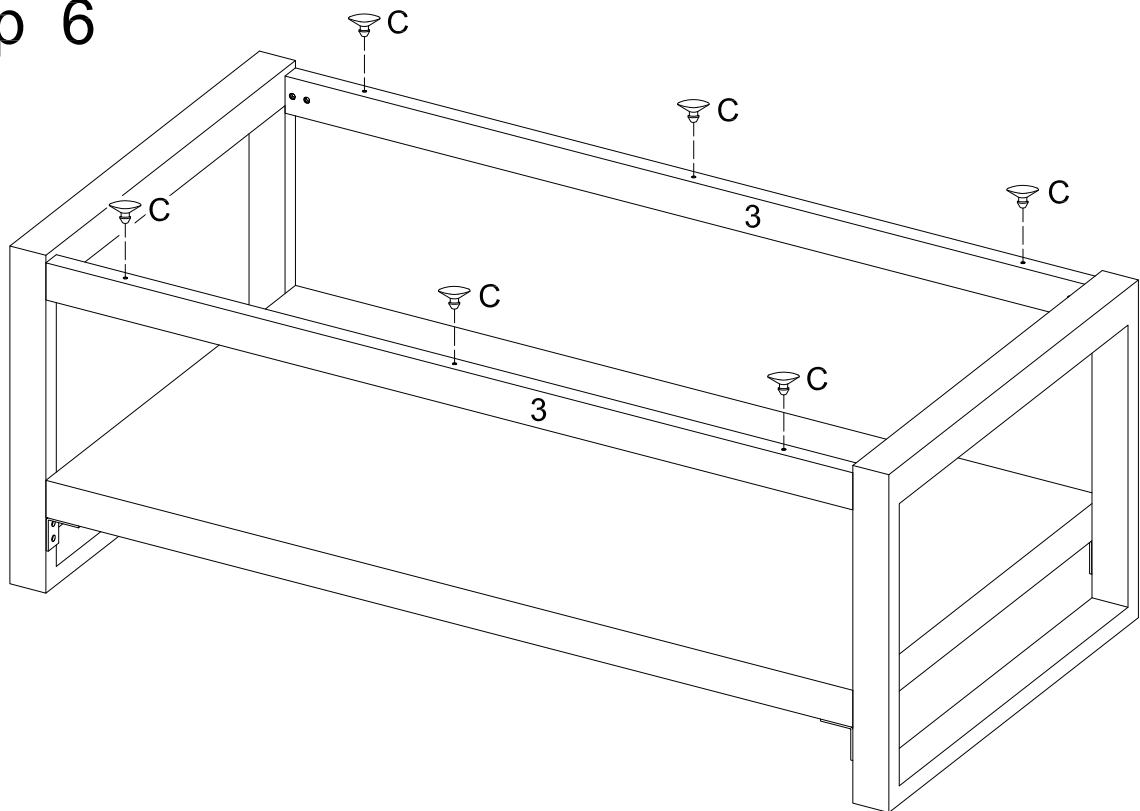

Insert the rubber suction cup into the metal bars (3).

Step 7

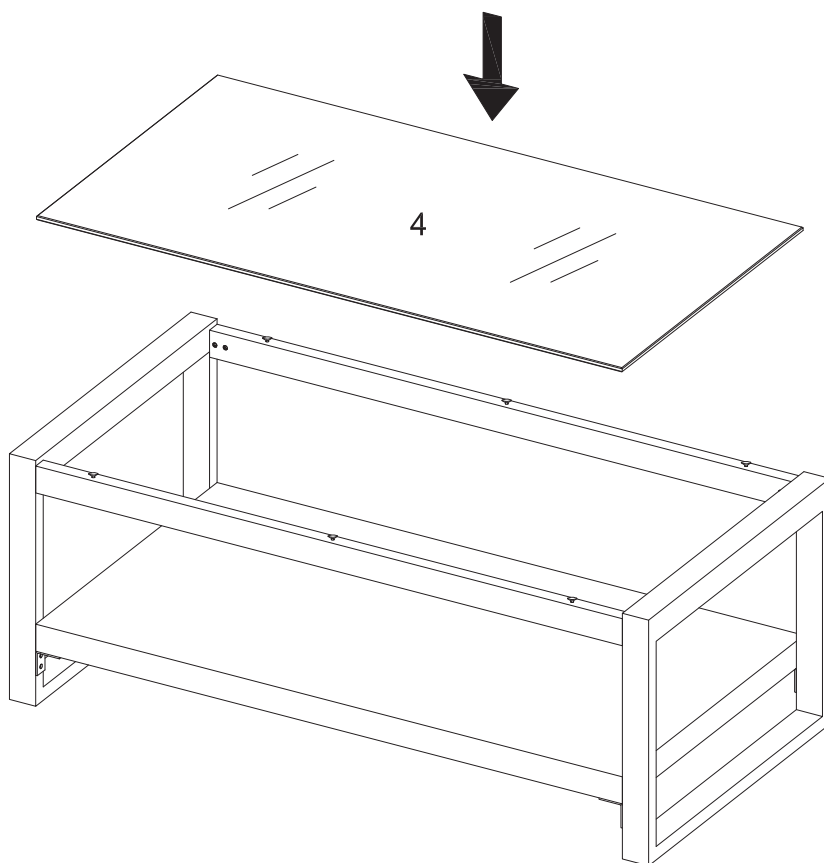

Place the glass (4) on top of the metal bars.

Step 8

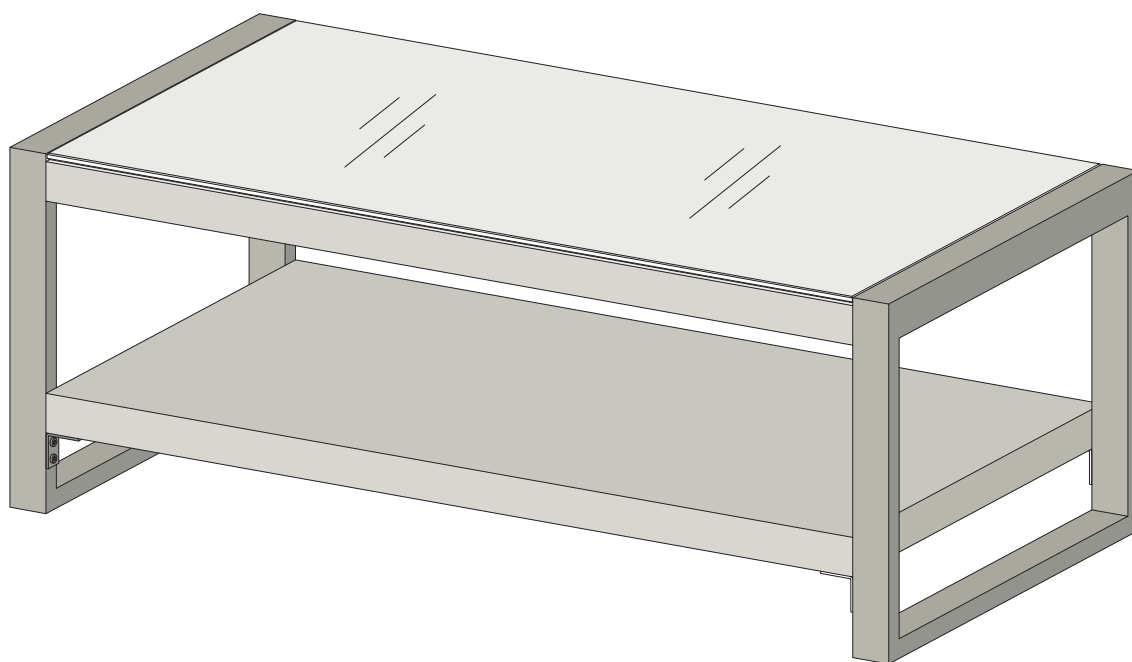

Final Assembly