

Quick Start Guide



for Magnum Shear Model #520

In the Box:		In the Hardware Kit:	
(1) Power Assembly	(1) Tail	Item A. (4) 6mm x 65mm PH Phillips Machine Screws	Item E. (4) #10 x 1 FH Phillips Self Tapping Screws
(1) Handle Assembly	(2) Rails	Item B. (4) M6 Star Washers	Item F. (2) M8 x 50mm Hex Bolts
(1) Angle Guide	(1) Hone Stone	Item C. (6) 6mm x 25mm PH Phillips Machine Screws	Item G. (1) M6 Thumbscrew (installed)
(1) Table	(1) Hardware Kit	Item D. (5) M6 x 16mm FH Phillips Machine Screws	

The Hardware Kit is used in multiple models. Your Shear may not use all of the items listed.

for Magnum Shear Model #526

In the Box:		In the Hardware Kit:	
(1) Power Assembly	(1) Tail	Item A. (8) 6mm x 65mm PH Phillips Machine Screws	Item E. (4) #10 x 1 FH Phillips Self Tapping Screws
(1) Handle Assembly	(4) Rails	Item B. (8) M6 Star Washers	Item F. (2) M8 x 50mm Hex Bolts
(1) Angle Guide	(1) Hone Stone	Item C. (8) 6mm x 25mm PH Phillips Machine Screws	Item G. (1) M6 Thumbscrew (installed)
(1) Table	(1) Hardware Kit	Item D. (6) M6 x 16mm FH Phillips Machine Screws	

The Hardware Kit is used in multiple models. Your Shear may not use all of the items listed.

ASSEMBLING YOUR SHEAR

Tools needed: #2 & #3 Phillips head screwdrivers, 1/2" socket or wrench.

IMPORTANT! Start all screws BY HAND when assembling your shear. This will help avoid cross-threading.

1. ATTACH RAILS

Attach rails to Power Assembly base using *Item A* screws, fitted with *Item B* star washers.

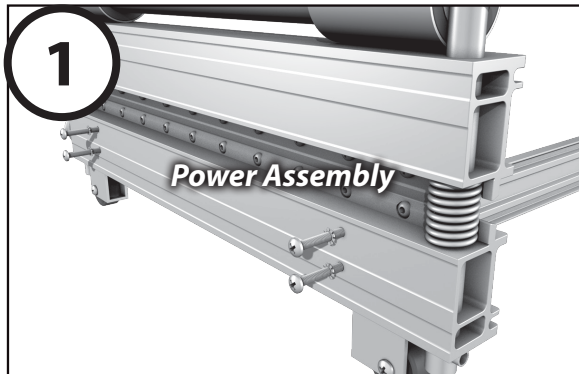

Model
520

2. ATTACH TAIL

Attach tail to rails using *Item C* screws. Make sure holes in tail are facing up.

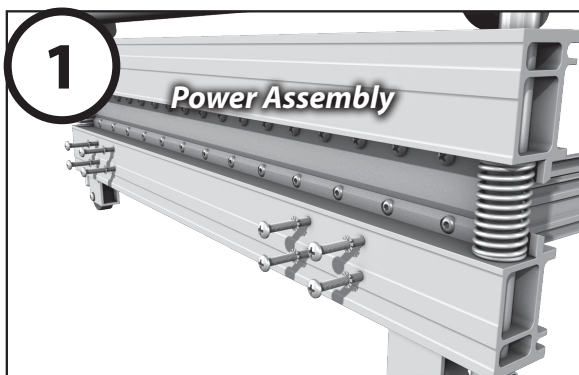
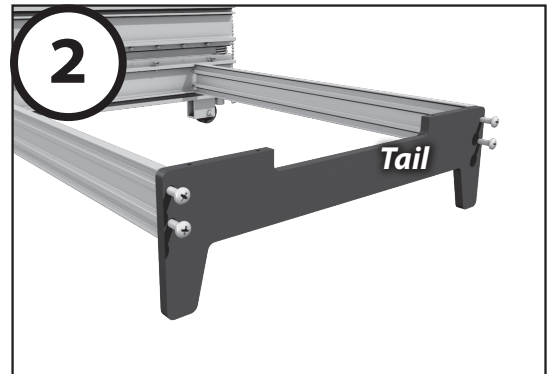

Model
526

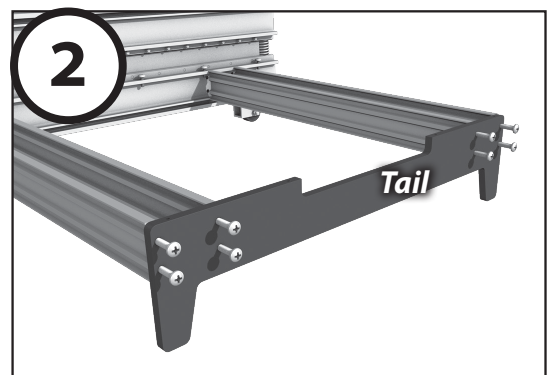

SET UP

3. ATTACH TABLE

A. Attach front of table to base, using *Item D* screws. Tighten with #3 Phillips.

B. Attach back of table to tail using *Item E* self tapping screws. Tighten with #2 Phillips.

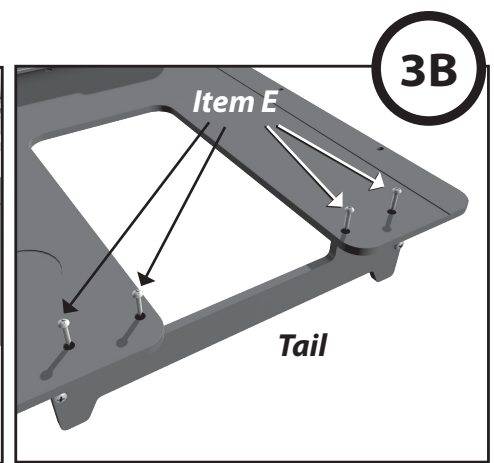
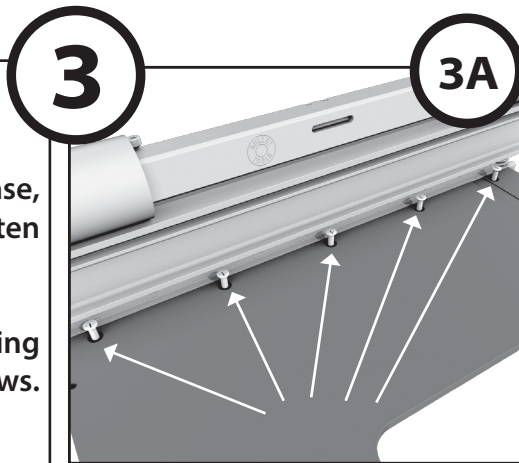

4. TO ATTACH HANDLE:

Insert *Item F* bolts and tighten with 1/2" (13mm) wrench.

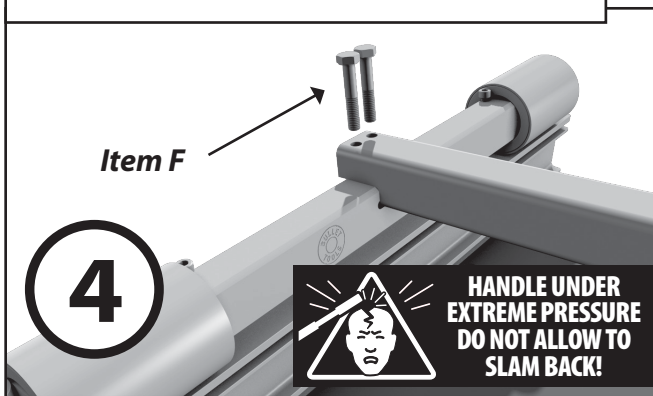

5. ATTACH ANGLE GUIDE

Install angle guide and tighten *Item G* thumbscrew.

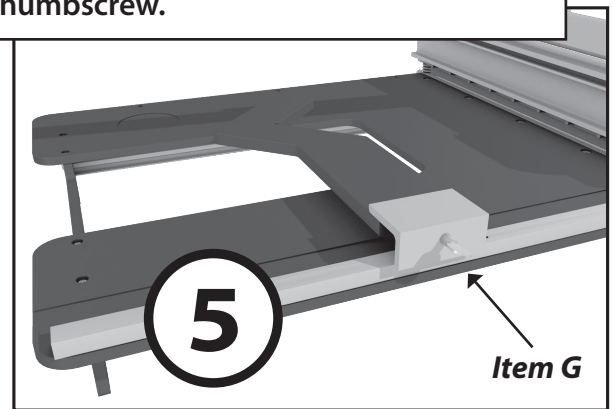

MAKING CUTS

1 While gently pushing handle down, pull Safety Lock pin out, lift handle.

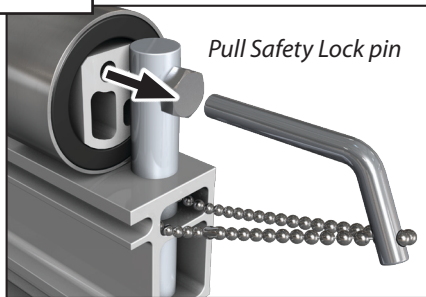

2 Place product on table. Bring handle down until blade touches material.

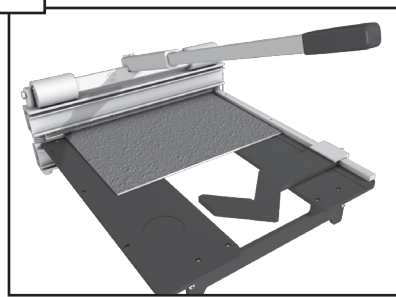

3 Push the handle down until the material is completely cut.

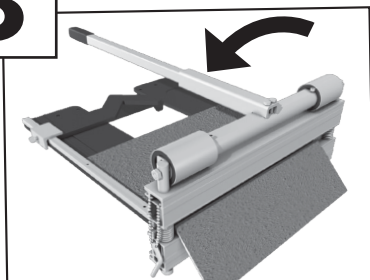

CUT GUIDE	
Maximum Thickness 520 = 7/16"	Maximum Thickness 526 = 1"
Carpet Tile	
Luxury Vinyl Tile	
Commercial Vinyl Tile	
VCT	
Parquet	
PVC Tile	
Rubber Tile	
Soft Plastic	

For manuals, registration, warranty info, accessories, & tips on using and maintaining your Magnum Shear, go to BulletTools.com or scan the QR code ->

