



21in Mulching/Rear Bagging Lawn Mower

- Model No. 10730—Serial No. 316000001 and Up
- Model No. 10732—Serial No. 316000001 and Up
- Model No. 10734—Serial No. 316000001 and Up
- Model No. 17730—Serial No. 316000001 and Up
- Model No. 17732—Serial No. 316000001 and Up
- Model No. 17734—Serial No. 316000001 and Up

Operator's Manual

Introduction

This rotary-blade, walk-behind lawn mower is intended to be used by residential homeowners. It is designed primarily for cutting grass on well-maintained lawns on residential properties. It is not designed for cutting brush or for agricultural uses.

Read this information carefully to learn how to operate and maintain your product properly and to avoid injury and product damage. You are responsible for operating the product properly and safely.

You may contact Lawn-Boy directly at www.Lawn-Boy.com for product and accessory information, help finding a dealer, or to register your product.

Whenever you need service, genuine Lawn-Boy parts, or additional information, contact an Authorized Service Dealer or Lawn-Boy Customer Service and have the model and serial numbers of your product ready. Figure 1 identifies the location of the model and serial numbers on the product. Write the numbers in the space provided.

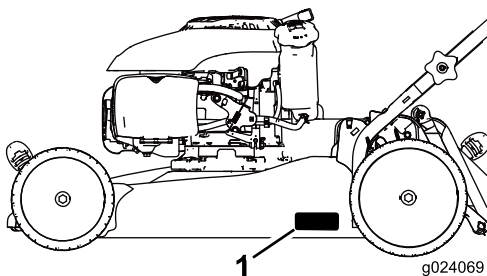

Figure 1

1. Model and serial number plate

Model No. _____
Serial No. _____

This manual identifies potential hazards and has safety messages identified by the safety alert symbol (Figure 2), which signals a hazard that may cause serious injury or death if you do not follow the recommended precautions.



Figure 2

1. Safety alert symbol

This manual uses 2 words to highlight information.

Important calls attention to special mechanical information and **Note** emphasizes general information worthy of special attention.

Receive a complimentary side-discharge chute by completing the *Discharge Chute Order Form* when you register your product at www.lawnboy.com/register. Please allow 1 to 2 weeks for delivery (subject to availability).

WARNING

CALIFORNIA Proposition 65 Warning

This product contains a chemical or chemicals known to the State of California to cause cancer, birth defects, or other reproductive harm.

The engine exhaust from this product contains chemicals known to the State of California to cause cancer, birth defects, or other reproductive harm.

It is a violation of California Public Resource Code Section 4442 or 4443 to use or operate the engine on any forest-covered, brush-covered, or grass-covered land unless the engine is equipped with a spark arrester, as defined in Section 4442, maintained in effective working order or the



engine is constructed, equipped, and maintained for the prevention of fire.

This spark ignition system complies with Canadian ICES-002.

The enclosed *Engine Owner's Manual* is supplied for information regarding the US Environmental Protection Agency (EPA) and the California Emission Control Regulation of emission systems, maintenance, and warranty. Replacements may be ordered through the engine manufacturer.

Net Torque

The gross or net torque of this engine was laboratory rated by the engine manufacturer in accordance with the Society of Automotive Engineers (SAE) J1940. As configured to meet safety, emission, and operating requirements, the actual engine torque on this class of mower will be significantly lower.

Contents

Introduction	1
Safety	2
General Safety.....	2
Safety and Instructional Decals	3
Setup	4
1 Unfolding the Handle.....	4
2 Installing the Recoil-Starter Rope in the Rope Guide.....	5
3 Filling the Engine with Oil.....	5
4 Charging the Battery (Electric-start model only)	6
5 Assembling the Grass Bag.....	6
Product Overview	7
Operation	8
Before Operation	8
Before Operation Safety.....	8
Attachments/Accessories.....	8
Filling the Fuel Tank	8
Checking the Engine-Oil Level.....	9
Adjusting the Cutting Height	9
During Operation	10
During Operating Safety.....	10
Starting the Engine	10
Using the Self-propel Drive (Self-Propel model only)	11
Stopping the Engine	11
Mulching the Clippings	11
Bagging the Clippings	11
Operating Tips	12
After Operation	12
After Operating Safety	12
Folding the Handle.....	13
Maintenance	14
Recommended Maintenance Schedule(s)	14
Preparing for Maintenance.....	14
Servicing the Air Cleaner	15
Changing the Engine Oil	15

Charging the Battery (Electric-start model only)	16
Replacing the Fuse (Electric-start model only)	16
Replacing the Blade	17
Adjusting the Self-Propel Drive Cable (Self-propel model only).....	18
Cleaning the under the Machine.....	18
Storage	19
Preparing the Machine for Storage	19
Remove the Machine from Storage.....	19

Safety

This machine has been designed in accordance with ANSI B71.1-2012.

General Safety

This product is capable of amputating hands and feet and of throwing objects. Always follow all safety instructions to avoid serious personal injury.

Using this product for purposes other than its intended use could prove dangerous to you and bystanders.

- Read and understand the contents of this *Operator's Manual* before you start the engine. Ensure that everyone using this product knows how to use it and understands the warnings.
- Do not put your hands or feet near moving components of the machine.
- Do not operate the machine without all guards and other safety protective devices in place and working on the machine.
- Keep clear of any discharge opening. Keep bystanders a safe distance from the machine.
- Keep children out of the operating area. Never allow children to operate the machine.
- Stop the machine and shut off the engine before servicing, fueling, or unclogging the machine.

Improperly using or maintaining this machine can result in injury. To reduce the potential for injury, comply with these safety instructions and always pay attention to the safety-alert symbol, which means Caution, Warning, or Danger—personal safety instruction. Failure to comply with these instructions may result in personal injury or death.

You can find additional items of safety information in their respective sections throughout this manual.

Safety and Instructional Decals

Important: Safety and instruction decals are located near areas of potential danger. Replace damaged decals.

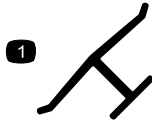

Manufacturer's Mark

1. Indicates that the blade is identified as a part from the original machine manufacturer.



94-8072

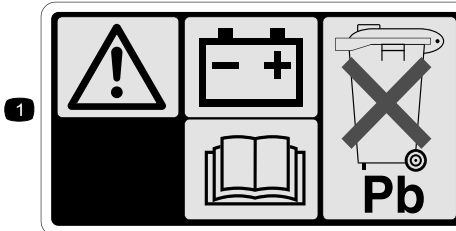

104-7953 (Electric-start model only)

1. Warning—read the *Operator's Manual* for information on charging the battery; contains lead; do not discard.
2. Read the *Operator's Manual*.



CALIFORNIA SPARK ARRESTER WARNING

Operation of this equipment may create sparks that can start fires around dry vegetation. A spark arrester may be required. The operator should contact local fire agencies for laws or regulations relating to fire prevention requirements. 117-2718

117-2718

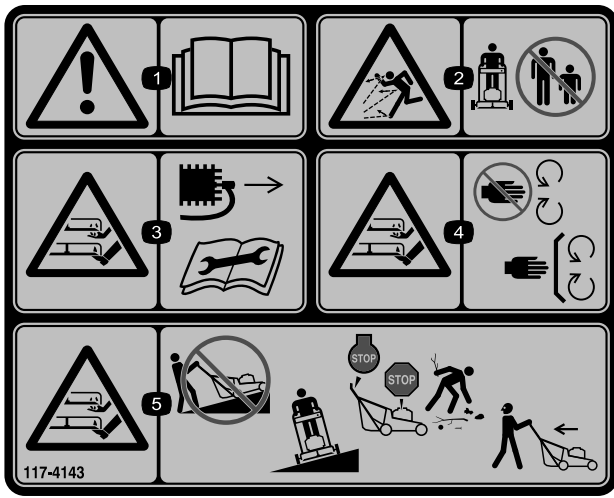

117-4143

1. Warning—read the *Operator's Manual*.
2. Thrown object hazard—keep bystanders a safe distance from the machine.
3. Cutting/dismemberment hazard of hand or foot, mower blade—disconnect the spark-plug wire and read the instructions before servicing or performing maintenance.
4. Cutting/dismemberment hazard of hand or foot, mower blade—stay away from moving parts and keep all guards and shields in place.
5. Cutting/dismemberment hazard of hand or foot, mower blade—do not mow up and down slopes, only mow across; stop the mower and engine, pick up debris before operating; look behind and down when reversing.

Setup

Important: Remove and discard the protective plastic sheet that covers the engine.

1

Unfolding the Handle

No Parts Required

Procedure

⚠ WARNING

Folding or unfolding the handle improperly can damage the cables, causing an unsafe operating condition.

- Do not damage the cables when folding or unfolding the handle.
- If a cable is damaged, contact an Authorized Service Dealer.

1. Remove the handle knobs from the machine housing (Figure 3).

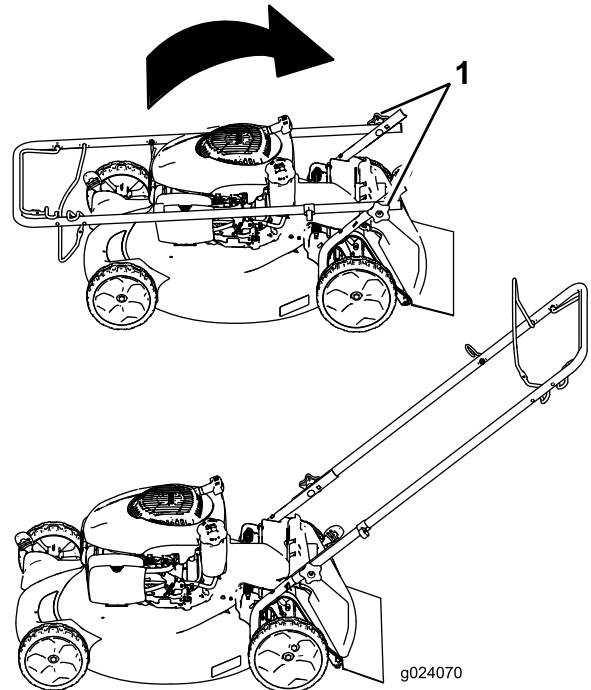

Figure 3

1. Handle knob (2)

Important: Route the cables to the outside of the handle as you unfold the handle (Figure 4).

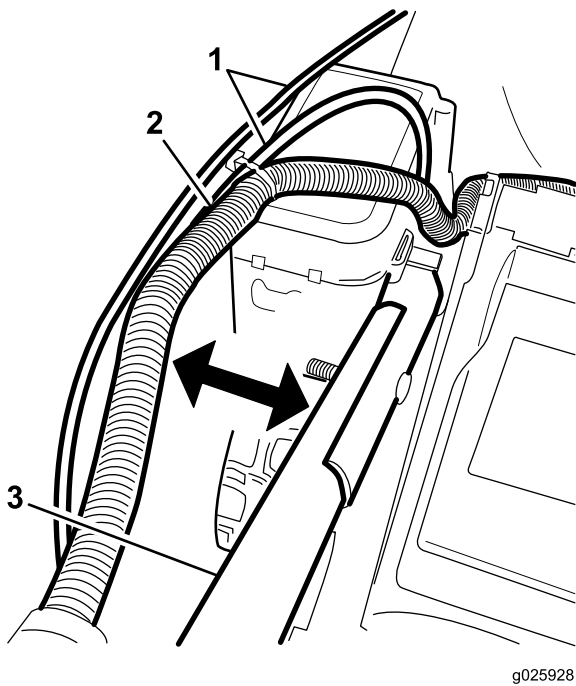

Figure 4
Electric-start model shown

1. Cables
2. Wiring harness (electric-start model only)
3. Handle

2. Move the handle to the operating position (Figure 3).
3. Install the handle knobs and tighten them firmly by hand.

2

Installing the Recoil-Starter Rope in the Rope Guide

No Parts Required

Procedure

Important: To start the engine safely and easily whenever you use the machine, install the recoil-starter rope in the rope guide.

Hold the blade-control bar to the upper handle and pull the recoil-starter rope through the rope guide on the handle (Figure 5).

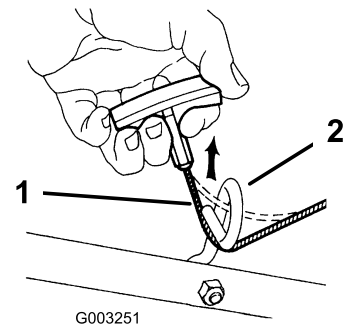

Figure 5

1. Recoil-starter rope
2. Rope guide

3

Filling the Engine with Oil

No Parts Required

Procedure

Important: Your machine does not come with oil in the engine. Before starting the engine, fill the engine with oil.

1. Move the machine to a level surface.
2. Remove the dipstick (Figure 6) and pour about 3/4 of the crankcase capacity of oil into the oil-fill tube.

Note: Max. fill: 0.53 L (18 oz), type: 10W-30 or SAE 30 detergent oil with an API service classification of SJ or higher.

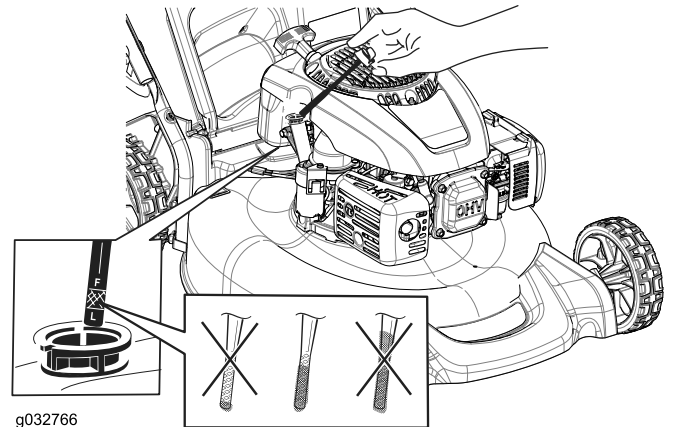

Figure 6

3. Wipe off the dipstick with a clean cloth.
4. Insert the dipstick into the oil-fill tube, but **do not** screw it in.
5. Remove the dipstick and read the oil level on the dipstick (Figure 6).

- If the oil level is low, add a small amount of oil slowly to the oil-fill tube, and then repeat steps 3 through 5 until the oil level on the dipstick is correct.
- If the oil level is high, drain the excess oil until the oil level on the dipstick is correct. To drain the excess oil, refer to [Changing the Engine Oil \(page 15\)](#).

Important: If the oil level in the crankcase is too low or too high and you run the engine, you may damage the engine.

6. Install the dipstick securely.

Important: Change the engine oil after the first 5 operating hours; change it yearly thereafter. Refer to [Changing the Engine Oil \(page 15\)](#).

4

Charging the Battery (Electric-start model only)

No Parts Required

Procedure

Refer to [Charging the Battery \(Electric-start model only\) \(page 16\)](#).

5

Assembling the Grass Bag

No Parts Required

Procedure

1. Slip the grass bag over the frame as shown in [Figure 7](#).

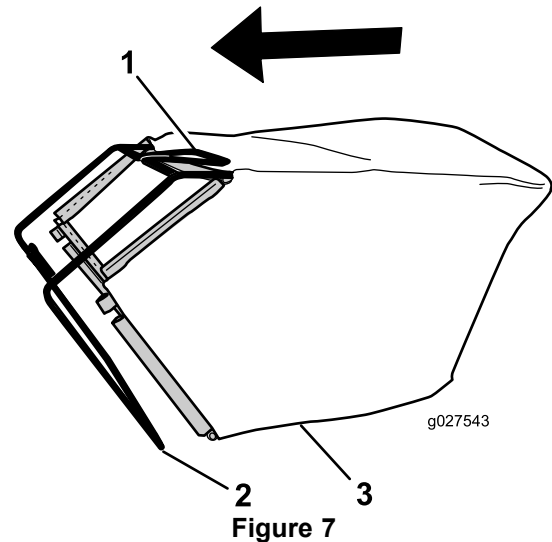

- | | |
|-----------|--------------|
| 1. Handle | 3. Grass bag |
| 2. Frame | |

Note: Do not slip the bag over the handle ([Figure 7](#)).

2. Hook the bottom channel of the bag onto the bottom of the frame ([Figure 8](#)).

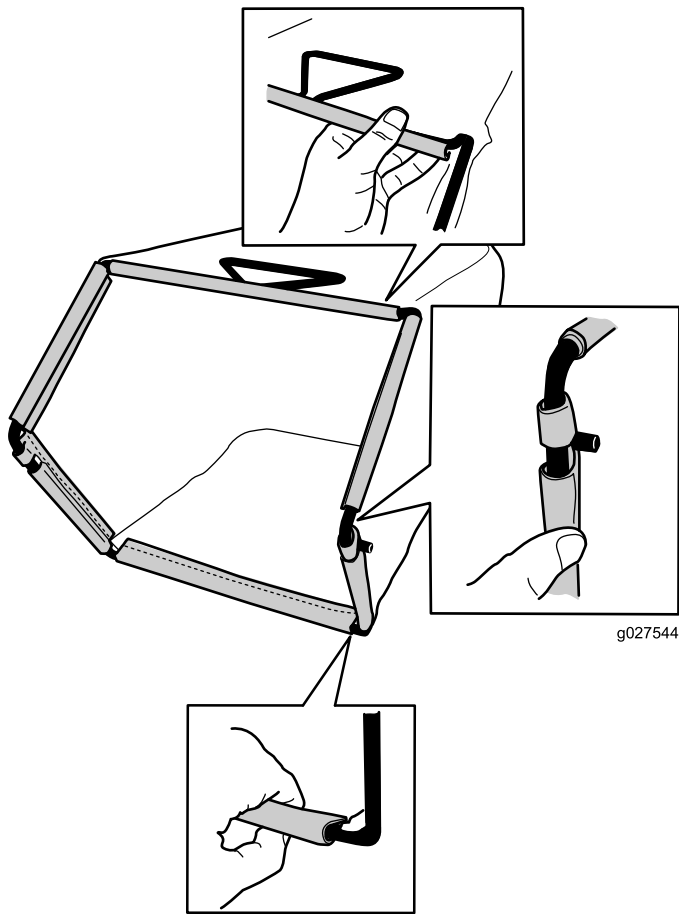

Figure 8

-
- Hook the top and side channels of the bag onto the top and sides of the frame, respectively ([Figure 8](#)).

Product Overview

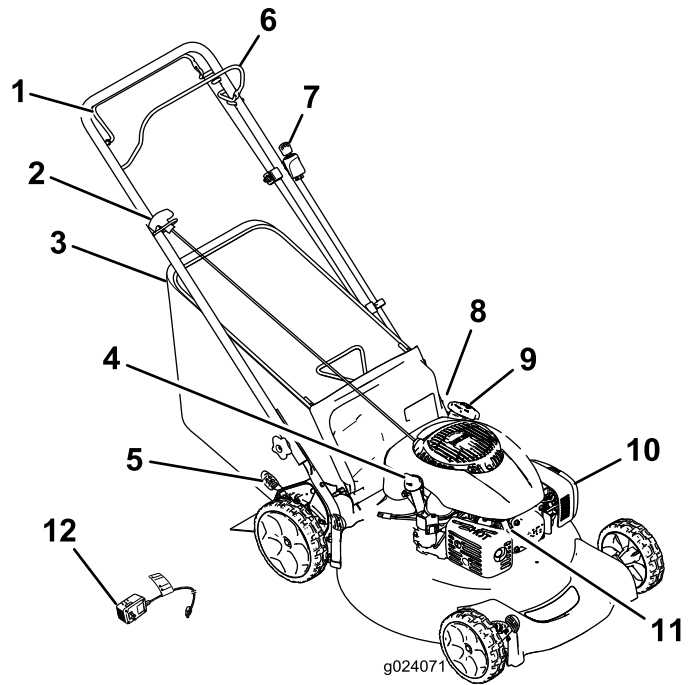

Figure 9

Electric-start model shown

- | | |
|---|---|
| 1. Self-propel-drive bar (self-propel model only) | 7. Ignition key (electric-start model only) |
| 2. Recoil-start handle | 8. Battery (not shown; electric-start model only) |
| 3. Grass bag | 9. Fuel-tank cap |
| 4. Oil fill/Dipstick | 10. Air filter |
| 5. Cutting-height lever (2) | 11. Spark plug |
| 6. Blade-control bar | 12. Battery charger (electric-start model only) |
-

Operation

Before Operation

Before Operation Safety

General Safety

- Become familiar with the safe operation of the equipment, operator controls, and safety signs.
- Check that all guards and safety devices, such as deflectors and/or grass catcher, are in place and working properly.
- Always inspect the machine to ensure that the blades, blade bolts, and cutting assembly are not worn or damaged.
- Inspect the area where you will use the machine and remove all objects that the machine could throw.
- Adjusting the cutting height may bring you into contact with the moving blade, causing serious injury.
 - Shut off the engine and wait for all moving parts to stop.
 - Do not put your fingers under the housing when adjusting the cutting height.

Fuel Safety

⚠ DANGER

Fuel is extremely flammable and highly explosive. A fire or explosion from fuel can burn you and others and can damage property.

- **To prevent a static charge from igniting the fuel, place the container and/or machine directly on the ground before filling, not in a vehicle or on an object.**
- **Fill the fuel tank outdoors, in an open area, when the engine is cold. Wipe up any fuel that spills.**
- **Do not handle fuel when smoking or around an open flame or sparks.**
- **Store fuel in an approved container and keep it out of the reach of children.**

⚠ WARNING

Fuel is harmful or fatal if swallowed. Long-term exposure to vapors can cause serious injury and illness.

- **Avoid prolonged breathing of vapors.**
- **Keep your hands and face away from the nozzle and the fuel-tank opening.**
- **Keep fuel away from your eyes and skin.**

Attachments/Accessories

A selection of Lawn-Boy approved attachments and accessories is available for use with the machine to enhance and expand its capabilities. Contact your Authorized Service Dealer or Distributor or go to www.Lawn-Boy.com for a list of all approved attachments and accessories.

Filling the Fuel Tank

⚠ DANGER

Gasoline is extremely flammable and explosive. A fire or explosion from gasoline can burn you and others.

- **To prevent a static charge from igniting the gasoline, place the container and/or machine directly on the ground before filling, not in a vehicle or on an object.**
- **Fill the tank outdoors when the engine is cold. Wipe up spills.**
- **Do not handle gasoline when smoking or around an open flame or sparks.**
- **Store gasoline in an approved fuel container, out of the reach of children.**
- For best results, use only clean, fresh (less than 30 days old), unleaded gasoline with an octane rating of 87 or higher ((R+M)/2 rating method).
- Oxygenated fuel with up to 10% ethanol or 15% MTBE by volume is acceptable.
- **Ethanol:** Gasoline with up to 10% ethanol (gasohol) or 15% MTBE (methyl tertiary butyl ether) by volume is acceptable. Ethanol and MTBE are not the same. Gasoline with 15% ethanol (E15) by volume is not approved for use. **Never use gasoline that contains more than 10% ethanol by volume**, such as E15 (contains 15% ethanol), E20 (contains 20% ethanol), or E85 (contains up to 85% ethanol). Using unapproved gasoline may cause performance problems and/or engine damage which may not be covered under warranty.
- **Do not** use gasoline containing methanol.
- **Do not** store fuel either in the fuel tank or in fuel containers over the winter unless a fuel stabilizer is used.
- **Do not** add oil to gasoline.

Important: To reduce starting problems, add fuel stabilizer to the fuel all season, mixing it with gasoline less than 30 days old.

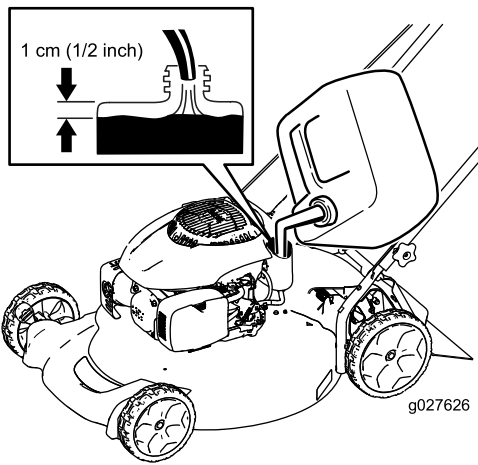

Figure 10

Important: If the oil level in the crankcase is too low or too high and you run the engine, you may damage the engine.

6. Install the dipstick securely.

Adjusting the Cutting Height

⚠ WARNING

Adjusting the cutting height may bring you into contact with the moving blade, causing serious injury.

- Stop the engine and wait for all moving parts to stop.
- Do not put your fingers under the housing when adjusting the cutting height.

⚠ CAUTION

If the engine has been running, the muffler will be hot and can severely burn you. Keep away from the hot muffler.

Adjusting the Cutting Height (High-wheel model only)

Adjust the cutting height as desired. Set the front wheels and the rear wheels to the same height.

Note: To raise or lower the machine, move the cutting-height levers as shown in Figure 12.

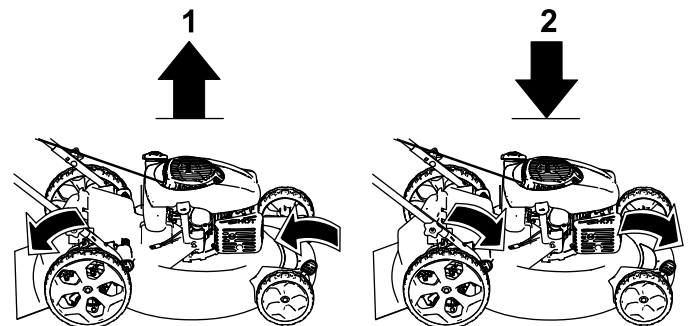

Figure 12

1. Raise the machine
2. Lower the machine

Note: The cutting height settings are 32 mm (1-1/4 inches); 44 mm (1-3/4 inches); 57 mm (2-1/4 inches); 70 mm (2-3/4 inches); 83 mm (3-1/4 inches); and 95 mm (3-3/4 inches).

Checking the Engine-Oil Level

Service Interval: Before each use or daily

Max. fill: 0.53 L (18 oz), type: 10W-30 or SAE 30 detergent oil with an API service classification of SJ or higher.

1. Move the machine to a level surface.
2. Remove the dipstick (Figure 11).

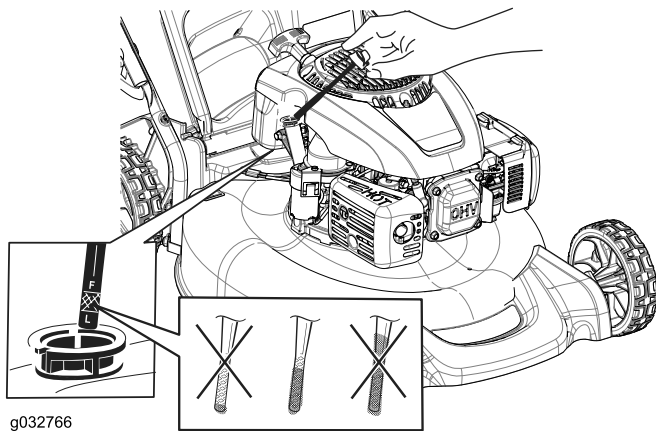

Figure 11

3. Wipe off the dipstick end with a clean cloth.
4. Insert the dipstick into the oil-fill tube, but **do not** screw it in.
5. Remove the dipstick and read the oil level; refer to Figure 11.
 - If the oil level is low, add a small amount of oil slowly to the oil-fill tube, and then repeat steps 3 through 5 until the oil level on the dipstick is correct.
 - If the oil level is high, drain the excess oil until the oil level on the dipstick is correct. To drain the excess oil, refer to [Changing the Engine Oil](#) (page 15).

Adjusting the Cutting Height (Regular-wheel model only)

Adjust the cutting height as desired. Set the front wheels and the rear wheels to the same height.

Note: To raise or lower the machine, move the cutting-height levers as shown in [Figure 13](#).

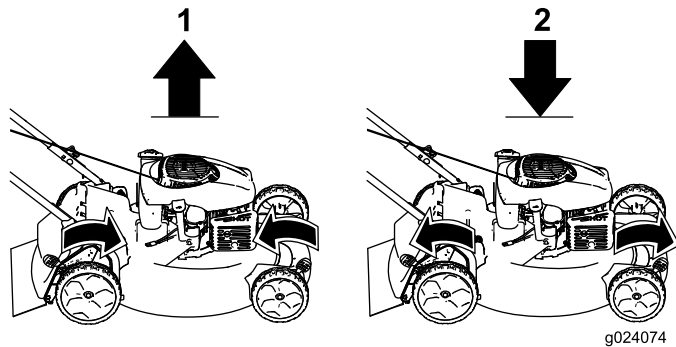

Figure 13

1. Raise the machine
2. Lower the machine

Note: The cutting height settings are 32 mm (1-1/4 inches); 44 mm (1-3/4 inches); 57 mm (2-1/4 inches); 70 mm (2-3/4 inches); 83 mm (3-1/4 inches); and 95 mm (3-3/4 inches).

During Operation

During Operating Safety

General Safety

- Wear appropriate clothing, including eye protection; slip-resistant, substantial footwear; and hearing protection. Tie back long hair, secure loose clothing, and do not wear jewelry.
- Do not operate the machine while ill, tired, or under the influence of alcohol or drugs.
- The blade is sharp; contacting the blade can result in serious personal injury. Shut off the engine and wait for all moving parts to stop before leaving the operating position.
- When you release the blade-control bar, the engine should shut off and the blade should stop within 3 seconds. If not, stop using your machine immediately and contact an Authorized Service Dealer.
- Operate the machine only in good visibility and appropriate weather conditions. Do not operate the machine when there is the risk of lightning.
- Wet grass or leaves can cause serious injury if you slip and contact the blade. Mow only in dry conditions.
- Use extreme care when approaching blind corners, shrubs, trees, or other objects that may block your view.

- Watch for holes, ruts, bumps, rocks, or other hidden objects. Uneven terrain could cause a slip-and-fall accident.
- Stop the machine and inspect the blades after striking an object or if there is an abnormal vibration in the machine. Make all necessary repairs before resuming operation.
- Before leaving the operating position, shut off the engine, remove the key, and wait for all moving parts to stop.
- If the engine has been running the muffler will be hot and can severely burn you. Keep away from the hot muffler.
- Check the grass catcher components and the discharge guard frequently and replace them with the manufacturer's recommended parts when necessary.
- Use accessories and attachments approved by the Lawn-Boy® Inc. only.

Slope Safety

- Mow across the face of slopes; never up and down. Use extreme caution when changing direction on slopes.
- Do not mow on excessively steep slopes. Poor footing could cause a slip-and-fall accident.
- Do not mow near drop-offs, ditches, or embankments. You could lose your footing or balance.

Starting the Engine

1. Hold the blade-control bar ([Figure 14](#)) against the handle.

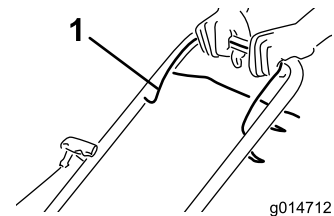

Figure 14

1. Blade-control bar

2. Turn the ignition key (electric-start model only; refer to [Figure 15](#)) or pull the recoil-start handle ([Figure 16](#)).

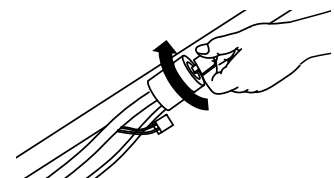

Figure 15

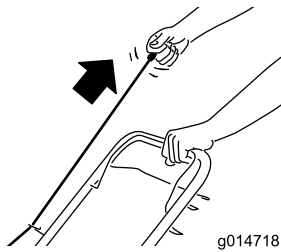

Figure 16

Note: If the machine does not start after several attempts, contact an Authorized Service Dealer.

Using the Self-propel Drive (Self-Propel model only)

To operate the self-propel drive, squeeze the self-propel drive bar (Figure 17) toward the handle and hold it.

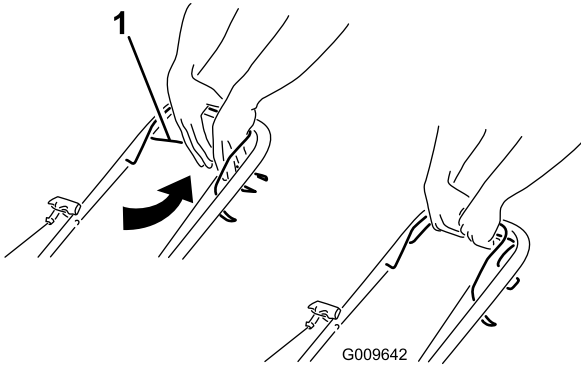

Figure 17

1. Self-propel drive bar

To disengage the self-propel drive, release the self-propel drive bar.

Note: The maximum self-propel ground speed is fixed. To reduce the ground speed, increase the space between the self-propel drive bar and the handle.

Stopping the Engine

Service Interval: Before each use or daily

To stop the engine, release the blade-control bar (Figure 18).

Note: Remove the ignition key when you leave the machine (electric-start model only).

Important: When you release the blade-control bar, both the engine and blade should stop within 3 seconds. If they do not stop properly, stop using your machine immediately and contact an Authorized Service Dealer.

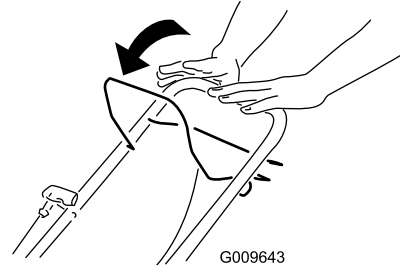

Figure 18

Mulching the Clippings

Your machine comes from the factory ready to mulch the grass and leaf clippings back into the lawn.

If the grass bag is on the machine, remove it before mulching the clippings. Refer to [Removing the Grass Bag](#) (page 12).

Bagging the Clippings

Use the grass bag when you want to collect grass and leaf clippings from the lawn.

⚠ WARNING

A worn grass bag could allow small stones and other similar debris to be thrown toward you or bystanders, resulting in serious personal injury or death.

Check the grass bag frequently. If it is damaged, install a new Lawn-Boy replacement bag.

⚠ WARNING

The blade is sharp; contacting the blade can result in serious personal injury.

Stop the engine and wait for all moving parts to stop before leaving the operating position.

Installing the Grass Bag

1. Lift up the rear deflector (Figure 19).

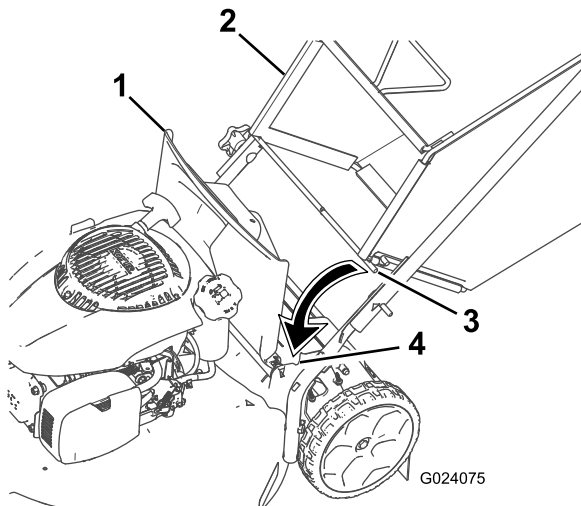

Figure 19

- | | |
|------------------------------------|----------------|
| 1. Rear deflector | 3. Rod end (2) |
| 2. Notch in the handle bracket (2) | 4. Grass bag |

2. Insert the rod ends of the grass bag into the notches in the handle brackets (Figure 19).
3. Allow the rear deflector to rest on the bag.

Removing the Grass Bag

1. Lift up the rear deflector (Figure 19).
2. Lift the grass-bag handle out from the notches on the handle brackets and remove the bag from the machine.
3. Close the rear deflector.

Operating Tips

General Mowing Tips

- Clear the area of sticks, stones, wire, branches, and other debris that the blade could hit.
- Avoid striking solid objects with the blade. Never deliberately mow over any object.
- If the machine strikes an object or starts to vibrate, immediately stop the engine, disconnect the wire from the spark plug, and examine the machine for damage.
- For best performance, install a new blade before the cutting season begins.
- Replace the blade when necessary with a Lawn-Boy replacement blade.

Cutting Grass

- Cut only about a third of the grass blade at a time. Do not cut below the 44 mm (1-3/4 inch) setting unless the grass is sparse or it is late fall when grass growth begins to slow down. Refer to [Adjusting the Cutting Height \(page 9\)](#).

- When cutting grass over 15 cm (6 inches) tall, mow at the highest cutting height setting and walk slower; then mow again at a lower setting for the best lawn appearance. If the grass is too long, the machine may plug and cause the engine to stall.
- Mow only dry grass or leaves. Wet grass and leaves tend to clump on the yard and can cause the machine to plug or the engine to stall.

⚠ WARNING

Wet grass or leaves can cause serious injury if you slip and contact the blade. Mow only in dry conditions.

- Alternate the mowing direction. This helps disperse the clippings over the lawn for even fertilization.
- If the finished lawn appearance is unsatisfactory, try 1 or more of the following:
 - Replace the blade or have it sharpened.
 - Walk at a slower pace while mowing.
 - Raise the cutting height on your machine.
 - Cut the grass more frequently.
 - Overlap cutting swaths instead of cutting a full swath with each pass.
 - Set the cutting height on the front wheels a notch lower than the rear wheels. For example, set the front wheels at 57 mm (2-1/4 inches) and the rear wheels at 70 mm (2-3/4 inches).

Cutting Leaves

- After cutting the lawn, ensure that half of the lawn shows through the cut leaf cover. You may need to make more than a single pass over the leaves.
- If there are more than 13 cm (5 inches) of leaves on the lawn, set the front cutting height 1 or 2 notches higher than the rear cutting height.
- Slow down your mowing speed if the machine does not cut the leaves finely enough.

After Operation

After Operating Safety

General Safety

- Clean grass and debris from the machine to help prevent fires. Clean up oil or fuel spills.
- Allow the engine to cool before storing the machine in any enclosure.
- Never store the machine or fuel container where there is an open flame, spark, or pilot light, such as on a water heater or on other appliances.

Hauling Safety

- Use care when loading or unloading the machine into a trailer or truck.
- Use full-width ramps for loading the machine into a trailer or truck. Do not exceed a 15° angle between the ramp and the trailer or truck.
- Tie the machine down securely using straps, chains, cable, or ropes. Both front and rear straps should be directed down and outward from the machine.

Folding the Handle

▲ WARNING

Folding or unfolding the handle improperly can damage the cables, causing an unsafe operating condition.

- Do not damage the cables when folding or unfolding the handle.
- If a cable is damaged, contact an Authorized Service Dealer.

1. Loosen the handle knobs until you can move the handle freely (Figure 20).

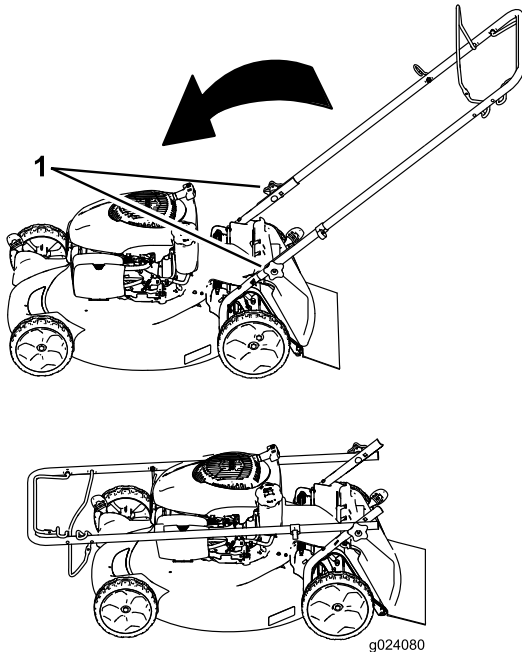

Figure 20

1. Handle knob (2)

2. Move the handle forward as shown in Figure 20.

Maintenance

Note: Determine the left and right sides of the machine from the normal operating position.

Recommended Maintenance Schedule(s)

Maintenance Service Interval	Maintenance Procedure
After the first 5 hours	<ul style="list-style-type: none"> Change the engine oil.
Before each use or daily	<ul style="list-style-type: none"> Check the engine oil level. Ensure that the engine stops within 3 seconds after releasing the blade-control bar.
After each use	<ul style="list-style-type: none"> Clean grass clippings and dirt from under the machine.
Every 25 hours	<ul style="list-style-type: none"> Check the air cleaner for dirty, loose, or damaged parts, and clean or replace them if necessary. Charge the battery for 24 hours (electric-start model only).
Every 100 hours	<ul style="list-style-type: none"> Replace the air cleaner element (more frequently when operating the machine in dusty or dirty operating conditions). Clean the cooling system (refer to your engine owner's manual). Replace the spark plug.
Before storage	<ul style="list-style-type: none"> Empty the fuel tank before repairs as directed and before annual storage.
Yearly	<ul style="list-style-type: none"> Change the engine oil. Replace the blade or have it sharpened (more frequently if the edge dulls quickly). Refer to your engine owner's manual for any additional yearly maintenance procedures.

Important: Refer to your engine owner's manual for additional maintenance procedures.

Preparing for Maintenance

1. Stop the engine and wait for all moving parts to stop.
2. Disconnect the spark-plug wire from the spark plug (Figure 21) before performing any maintenance procedure.

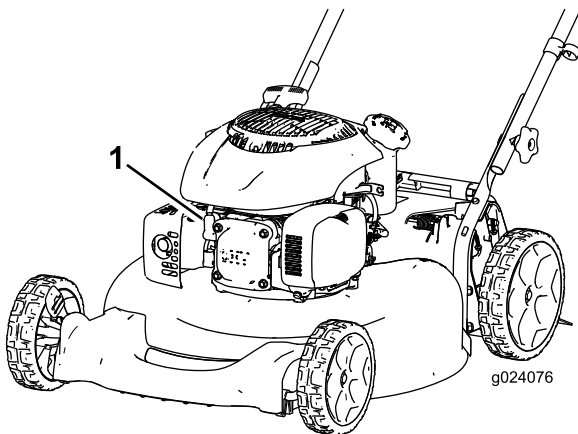

Figure 21

1. Spark-plug wire

Important: Before tipping the machine to change the oil or replace the blade, allow the fuel tank to run dry through normal usage. If you must tip the machine prior to running out of fuel, use a hand fuel pump to remove the fuel. Always tip the machine onto its side with the dipstick down.

▲ WARNING

Tipping the machine may cause the fuel to leak. Gasoline is flammable and explosive and can cause personal injury.

Run the engine dry or remove the gasoline with a hand pump; never siphon.

3. After performing the maintenance procedure(s), connect the spark-plug wire to the spark plug.

Servicing the Air Cleaner

Service Interval: Every 25 hours/Yearly (whichever comes first)—Check the air cleaner for dirty, loose, or damaged parts, and clean or replace them if necessary.

Every 100 hours/Yearly (whichever comes first)—Replace the air cleaner element (more frequently when operating the machine in dusty or dirty operating conditions).

1. Perform the pre-maintenance procedures; refer to [Preparing for Maintenance \(page 14\)](#).
2. Press down on the latch tabs on top of the air-cleaner cover ([Figure 22](#)).

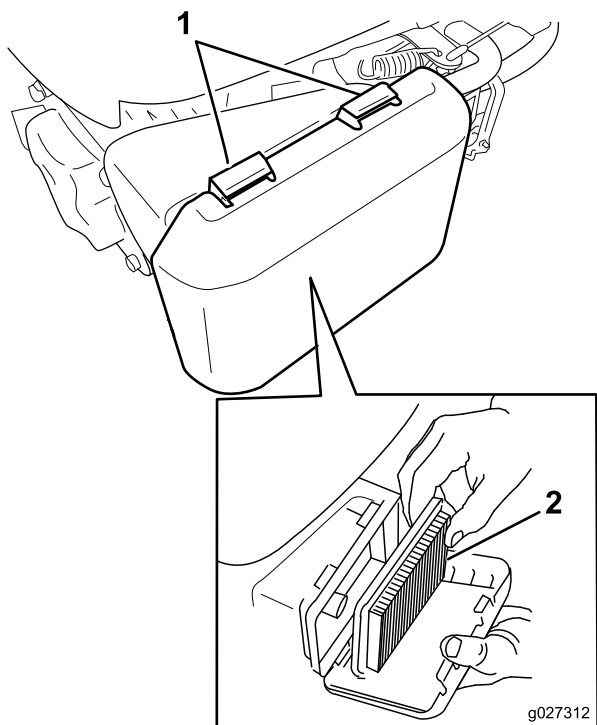

Figure 22

1. Latch tabs
2. Air-cleaner element

3. Open the cover.
4. Replace the air-cleaner element.
5. Install the cover.

Changing the Engine Oil

Service Interval: After the first 5 hours

Yearly

Run the engine a few minutes before changing the oil to warm it. Warm oil flows better and carries more contaminants.

1. Perform the pre-maintenance procedures; refer to [Preparing for Maintenance \(page 14\)](#).
2. Tip the machine onto its side, with the dipstick down, to drain the used oil out through the oil-fill tube ([Figure 23](#)).

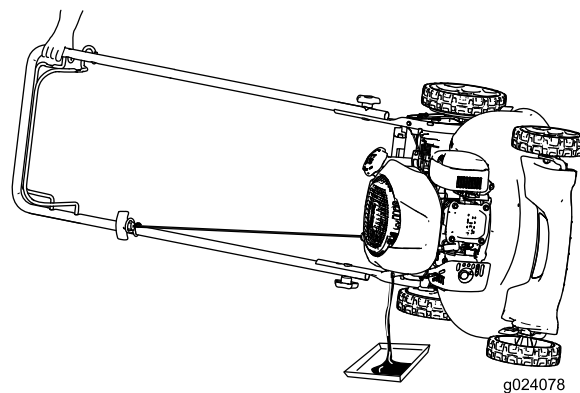

Figure 23

3. Remove the dipstick.
4. After draining the used oil, return the machine to the normal operating position.
5. Pour about 3/4 of the crankcase capacity of oil into the oil-fill tube.

Note: Max. fill: 0.53 L (18 oz), type: 10W-30 or SAE 30 detergent oil with an API service classification of SJ or higher.

6. Wipe off the dipstick end with a clean cloth.
7. Insert the dipstick into the oil-fill tube, but **do not** screw it in.
8. Remove the dipstick and read the oil level on the dipstick ([Figure 24](#)).

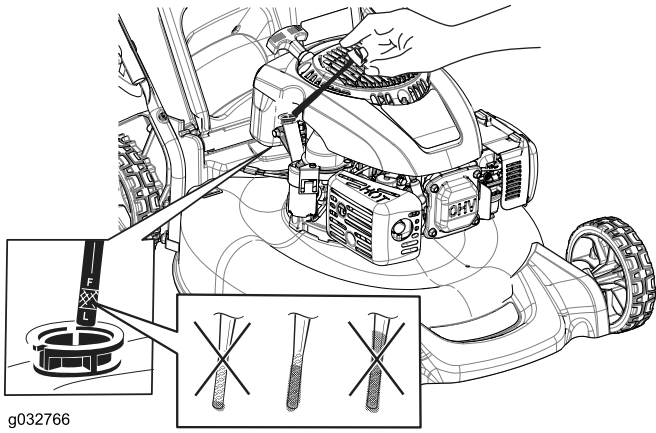

Figure 24

- If the oil level is low, add a small amount of oil slowly to the oil-fill tube, and then repeat steps 6 through 8 until the oil level on the dipstick is correct.
- If the oil level is high, drain the excess oil until the oil level on the dipstick is correct.

Important: If the oil level in the crankcase is too low or too high and you run the engine, you may damage the engine.

9. Install the dipstick securely.
10. Recycle the used oil properly.

Charging the Battery (Electric-start model only)

Service Interval: Every 25 hours

WARNING

CALIFORNIA Proposition 65 Warning

Battery posts, terminals, and related accessories contain lead and lead compounds, chemicals known to the State of California to cause cancer and reproductive harm. Wash hands after handling.

Charge the battery for 24 hours initially, then monthly (every 25 starts) or as needed. Always use the charger in a sheltered area and charge the battery at room temperature (70° or 22° C) whenever possible.

1. Connect the charger to the wire harness located below the ignition key (Figure 25).

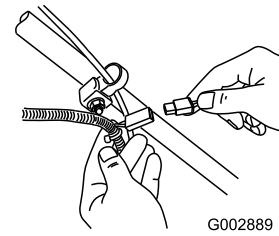

Figure 25

2. Plug the charger into a wall outlet.

Note: When the battery no longer holds a charge, recycle or dispose of the lead-acid battery according to local codes.

Note: Your battery charger may have a 2-color LED display that indicates the following states of charging:

- A red light indicates that the charger is charging the battery.
- A green light indicates that the charger is fully charged or the charger is disconnected from the battery.
- A flashing light that alternates between red and green indicates that the battery is nearly fully charged. This state lasts only a few minutes until the battery is fully charged.

Replacing the Fuse (Electric-start model only)

Your machine comes with a fuse that protects the electric starter. If the battery does not charge or the engine does not run with the electric starter, the fuse may be blown. Replace it with a 40-amp plug-in type fuse.

Important: You cannot start the machine with the electric starter or charge the battery unless you install the fuse.

1. Unclip the battery cover and remove it (Figure 26).

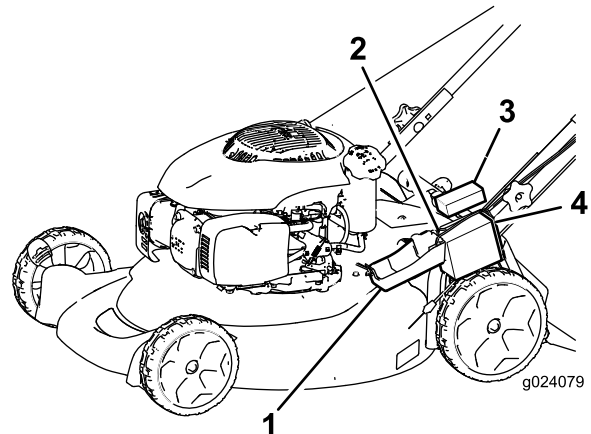
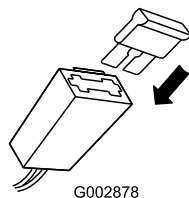

Figure 26

- | | |
|------------------|----------------|
| 1. Battery cover | 3. Battery |
| 2. Foam | 4. Fuse holder |

2. Insert the fuse into the fuse holder (Figure 27).



G002878
Figure 27

3. Install the battery cover.

Replacing the Blade

Service Interval: Yearly

Important: You will need a torque wrench to install the blade properly. If you do not have a torque wrench or are uncomfortable performing this procedure, contact an Authorized Service Dealer.

Examine the blade whenever you run out of gasoline. If the blade is damaged or cracked, replace it immediately. If the blade edge is dull or nicked, have it sharpened or replace it.

⚠ WARNING

The blade is sharp; contacting the blade can result in serious personal injury.

- Disconnect the wire from the spark plug.
 - Wear gloves when servicing the blade.
1. Disconnect the spark-plug wire from the spark plug. Refer to [Preparing for Maintenance \(page 14\)](#).
 2. Tip the machine onto its side, with the air filter up.
 3. Use a block of wood to hold the blade steady.
 4. Remove the blade (turn the blade bolt counterclockwise), saving all the mounting hardware.
 5. Install the new blade (turn the blade bolt clockwise) and all mounting hardware ([Figure 28](#)).

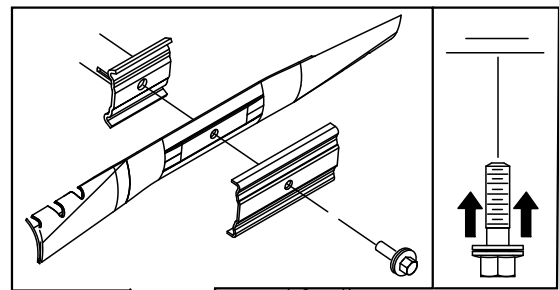

G002599
Figure 28

Important: Position the curved ends of the blade to point toward the machine housing.

6. Use a torque wrench to tighten the blade bolt to 82 N-m (60 ft-lb).

Important: A bolt torqued to 82 N-m (60 ft-lb) is very tight. While holding the blade with a block of wood, put your weight behind the ratchet or wrench and tighten the bolt securely. This bolt is very difficult to overtighten.

Adjusting the Self-Propel Drive Cable (Self-propel model only)

Whenever you install a new self-propel cable or if the self-propel drive is out of adjustment, adjust the self-propel drive cable.

1. Loosen the cable-support nut (Figure 29).

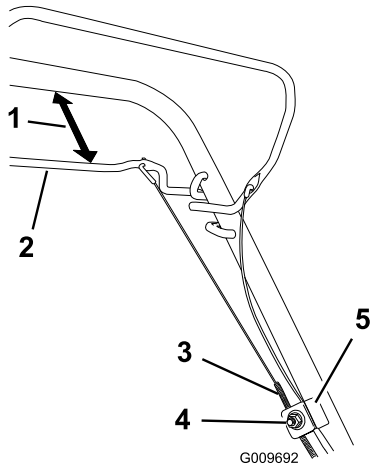

Figure 29

- | | |
|------------------------------------|----------------------|
| 1. 25 to 38 mm (1 to 1-1/2 inches) | 4. Cable-support nut |
| 2. Self-propel drive bar | 5. Cable support |
| 3. Cable jacket | |

2. Hold the self-propel bail 25 to 38 mm (1 to 1-1/2 inches) from the handle (Figure 29).
3. Pull down the cable jacket (toward the machine) until there is no slack in the cable (Figure 29).
4. Tighten the nut on the cable support.
5. Release the self-propel drive bar and ensure that the cable is loose.

Note: The cable must be loose with the self-propel drive bar in the released position; otherwise, the machine may creep when you disengage the bar.

Cleaning the under the Machine

Service Interval: After each use

⚠ WARNING

The machine may dislodge material from under the machine.

- Wear eye protection.
 - Stay in the operating position (behind the handle).
 - Do not allow bystanders in the area.
1. With the engine running on a flat paved surface, spray a stream of water in front of the **right** rear wheel (Figure 30).

The water will splash into the path of the blade, cleaning out the clippings.

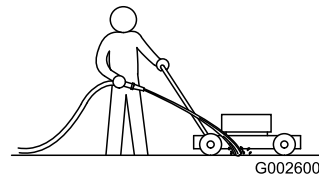

Figure 30

2. When no more clippings come out, stop the water and move the machine to a dry area.
3. Run the engine for a few minutes to dry the underside of the machine to prevent it from rusting.

Storage

Store the machine in a cool, clean, dry place.

Preparing the Machine for Storage

⚠ WARNING

Gasoline vapors can explode.

- **Do not store gasoline more than 30 days.**
 - **Do not store the machine in an enclosure near an open flame.**
 - **Allow the engine to cool before storing it.**
1. On the last refueling of the year, add fuel stabilizer to the fuel as directed by the engine manufacturer.
 2. Run the machine until the engine stops from running out of fuel.
 3. Prime the engine and start it again.
 4. Allow the engine to run until it stops. When you can no longer start the engine, it is sufficiently dry.
 5. Disconnect the wire from the spark plug.
 6. Remove the spark plug, add 1 oz. (30 ml) of oil through the spark plug hole, and pull the starter rope **slowly** several times to distribute oil throughout the cylinder to prevent cylinder corrosion during the off-season.
 7. Install the spark plug and tighten it with a torque wrench to 15 ft-lb (20 N-m).
 8. Tighten all nuts, bolts, and screws.
 9. Charge the battery for 24 hours, then unplug the battery charger and store the machine in an unheated area. If you must store the machine in a heated area, you must charge the battery every 90 days.

Remove the Machine from Storage

1. Check and tighten all fasteners.
2. Remove the spark plug and spin the engine rapidly by pulling the recoil-start handle or using the electric starter (electric-start model only) to blow the excess oil from the cylinder.
3. Install the spark plug and tighten it with a torque wrench to 20 N-m (15 ft-lb).
4. Perform any maintenance procedures; refer to [Maintenance \(page 14\)](#).
5. Check the engine-oil level; refer to [Checking the Engine-Oil Level \(page 9\)](#).
6. Fill the fuel tank with fresh gasoline; refer to [Filling the Fuel Tank \(page 8\)](#).
7. Connect the wire to the spark plug.
8. Charge the battery for 24 hours (electric-start model only); refer to [Charging the Battery \(Electric-start model only\) \(page 16\)](#).



The Lawn-Boy No-Worry Warranty

A 2-Year Full Warranty (45 Day Limited Warranty for Commercial Use)

21 in. Mulching/Rear Bagging

Walk Power Mowers

The Lawn-Boy True Start Commitment

A 3-Year Full Warranty (Not Applicable for Commercial Use)

Conditions and Products Covered

Lawn-Boy Inc. and its affiliate, Lawn-Boy Warranty Company, pursuant to an agreement between them, jointly promise to repair the Lawn-Boy Product listed below if used for residential purposes*; if it is defective in materials or workmanship or if it stops functioning due to the failure of a component; or if the Lawn-Boy True Start engine will not start on the first or second pull, provided the routine maintenance required in the *Operator's Manual* have been performed.

This warranty covers the cost of parts and labor, but you must pay transportation costs.

The following time periods apply from the date of purchase:

Products	Warranty Period
21 in. Mulching/Rear Bagging Mowers and Attachments True Start Commitment	2 - year full warranty
Engine	3 - year full warranty
Battery	3 - year full warranty
Wear Items (Belts, blades, blade adaptors, grass bags, cables, and wheels)	1 - year full warranty
	90 days

Limited Warranty for Commercial Use*

Gas-powered Lawn-Boy Products used for commercial, institutional, or rental use, are warranted for 45 days against defects in materials or workmanship. Components failing due to normal wear are not covered by this warranty.

The True Start Commitment does not apply when the product is used commercially*.

Instructions for Obtaining Warranty Service

If you think that your Lawn-Boy Product contains a defect in materials or workmanship, or if a normal, able-bodied adult can no longer start your product's engine in one or two pulls, follow this procedure:

- Contact any Authorized Lawn-Boy Service Dealer to arrange service at their dealership. To locate a dealer convenient to you, refer to the *Yellow Pages* of your telephone directory (look under "Lawn Mowers") or access our web site at www.Lawn-Boy.com. You may also call the numbers listed in item #3 to use the 24-hour Lawn-Boy Dealer locator system.
- Bring the product and your proof of purchase (sales receipt) to the Service Dealer. The dealer will diagnose the problem and determine if it is covered under warranty.
- If for any reason you are dissatisfied with the Service Dealer's analysis or with the assistance provided, contact us at:

Customer Care Department
Lawn-Boy Inc.
8111 Lyndale Avenue South
Bloomington, MN 55420-1196
Toll free at 866-216-6032 (U.S. customers)
Toll free at 866-216-6031 (Canadian customers)

Owner Responsibilities

You must maintain your Lawn-Boy Product by following the maintenance procedures described in the *Operator's Manual*. Such routine maintenance, whether performed by a dealer or by you, is at your expense.

Countries Other than the United States or Canada

Customers who have purchased Lawn-Boy products exported from the United States or Canada should contact their Lawn-Boy Distributor (Dealer) to obtain guarantee policies for your country, province, or state. If for any reason you are dissatisfied with your Distributor's service or have difficulty obtaining guarantee information, contact the Lawn-Boy importer. If all other remedies fail, you may contact us at Lawn-Boy Warranty Company.

Australian Consumer Law: Australian customers will find details relating to the Australian Consumer Law either inside the box or at your local Lawn-Boy Dealer.

*Residential purposes means use of the product on the same lot as your home. Use at more than one location, or institutional or rental use, is considered commercial use and the commercial use warranty would apply.

Items and Conditions Not Covered

There is no other express warranty except for special emission system coverage and engine warranty coverage on some products. This express warranty does not cover the following:

- Cost of regular maintenance service or parts, such as filters, fuel, lubricants, oil changes, spark plugs, air filters blade sharpening or worn blades, cable/linkage adjustments, or brake and clutch adjustments
- Components failing due to normal wear
- Any product or part which has been altered or misused or neglected and requires replacement or repair due to accidents or lack of proper maintenance
- Pickup and delivery charges
- Repairs or attempted repairs by anyone other than an Authorized Lawn-Boy Service Dealer
- Repairs necessary due to failure to follow recommended fuel procedure (consult *Operator's Manual* for more details)
 - Removing contaminants from the fuel system is not covered
 - Use of old fuel (more than one month old) or fuel which contains more than 10% ethanol or more than 15% MTBE
 - Failure to drain the fuel system prior to any period of non-use over one month
- Repairs or adjustments to correct starting difficulties due to the following:
 - Failure to follow proper maintenance procedures or recommended fuel procedure
 - Rotary mower blade striking an object
- Special operational conditions where starting may require more than two pulls:
 - First time starts after extended period of non-use over three months or seasonal storage
 - Cool temperature starts such as those found in early spring and late autumn
 - Improper starting procedures - if you are having difficulty starting your unit, please check the *Operator's Manual* to ensure that you are using the correct starting procedures. This can save an unnecessary visit to an Authorized Lawn-Boy Service Dealer.

General Conditions

All repairs covered by these warranties must be performed by an Authorized Lawn-Boy Service Dealer using Lawn-Boy-approved replacement parts. Repair by an Authorized Lawn-Boy Service Dealer is your sole remedy under this warranty.

Lawn-Boy Inc. nor Lawn-Boy Warranty Company is liable for indirect, incidental, or consequential damages in connection with the use of the Lawn-Boy Products covered by these warranties, including any cost or expense of providing substitute equipment or service during reasonable periods of malfunction or non-use pending completion of repairs under these warranties.

Some states do not allow exclusions of incidental or consequential damages, so the above exclusions may not apply to you.

This warranty gives you specific legal rights, and you may also have other rights which vary from state to state.