



FOR MODEL 23111
Low Voltage Light Fixture

SAVE THESE INSTRUCTIONS
READ BEFORE USING
THIS PRODUCT.

LIMITED WARRANTY

Instructions for Assembling and Installing Hampton Bay Light Fixture

⚠ WARNING: Risk of fire or electrical shock

- For use with OUTDOOR low voltage landscape lighting systems ONLY.
 - NOT FOR USE with submersible or pool/spa equipment.
 - Do not install within 10 feet (3 m) of pools, spas, or fountains.
 - Do not connect with wet hands.
 - Do not submerge in water, the product can be damaged.
 - Do not repair or modify this product.
 - This product is not a toy and must not be operated by children. Low voltage cable can be buried to a maximum of 6 inches (15.2 cm).
 - If necessary to splice cable, carefully follow instructions that came with the connector you have purchased.
 - Do not use cable smaller than listed in chart below.
- SELECT CABLE.** Use the chart below to determine the MINIMUM gauge cable to be used, depending on the wattage of the power pack. Using larger cable will ensure maximum light output. For Hampton Bay cable, contact your supplier.

Power-Pack Wattage	Minimum Gauge Cable
217-300	12
157-216	14-12
121-156	16-14-12
0-120	18-16-14-12

INSTRUCTIONS PERTAINING TO A RISK OF FIRE, OR INJURY TO PERSONS

IMPORTANT SAFETY INSTRUCTIONS
Lighted lamp is HOT!

WARNING – To reduce the risk of FIRE OR INJURY TO PERSONS

- Turn off/unplug and allow to cool before replacing lamp.
- Lamp gets HOT quickly! Contact only switch/plug when turning on.
- Do not touch hot lens, guard, or enclosure.
- Keep lamp away from materials that may burn.
- Do not touch the lamp at any time. Use a soft cloth. Oil from skin may damage lamp.
- Do not operate the luminaire fitting with a missing or damaged shield.

⚠ WARNING: Risk of Fire or Electrical Shock

- Read power pack assemble instruction before attempting to install or hook up the power pack. Failure to follow directions may result in Risk of Fire or Electric Shock.
- Use only CSA or UL approved low-voltage cable. Failure to use the correct gauge cable or install it as directed in these instructions may result in Risk of Fire or Electric Shock.

Assemble the fixture

- 1) Unscrew the two screws (#1), and take off the top cover (#2). Install the light bulb (#3) [included], then fix back the top cover (#2) to fixture body (#4) by the two screws (#1).
- 2) Assemble fixture as shown in illustration above. Be sure to run wire leads through slot in stake.
- 3) Choose a location for your power pack very carefully. Give thought to where you plan to install your lighting fixtures and the location of your power outlet.
- 4) Lay the fixtures out where you want to locate them. The first fixture should be at least 10 wire feet from the power pack. **WARNING-RISK OF ELECTRICAL SHOCK: Do not place a fixture within 10 feet of a pool or spa.**
- 5) Run the low voltage cable to your fixtures as shown keeping cable runs as short as possible. In many cases, it is better to make two (2) cable runs from the power pack.

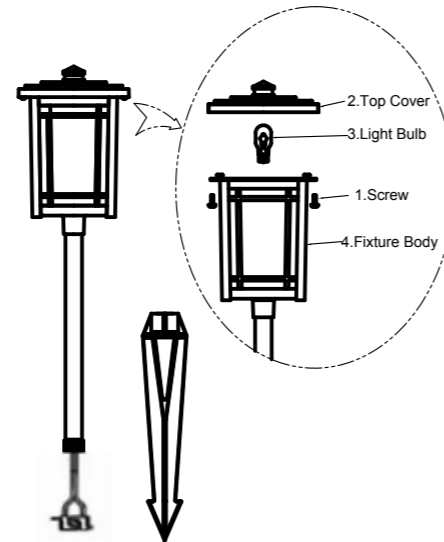

For dependable performance, use genuine Hampton Bay replacement parts

For customer service or to purchase replacement parts please visit our web site: www.homedepot.com
or call 1-877-527-0313
IMPORTANT: Please have product model number available when ordering.
YOU MUST KEEP YOUR RECEIPT FOR PROOF OF PURCHASE.

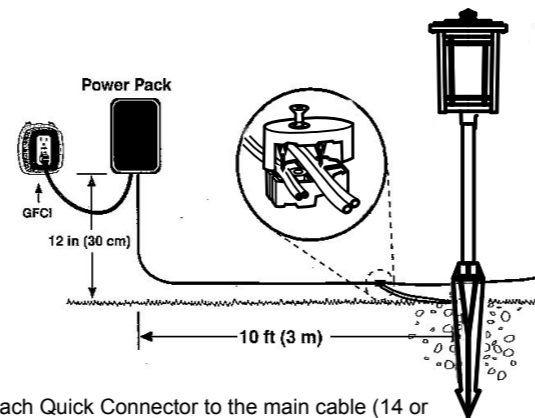

- 6) Install each Quick Connector to the main cable (14 or 16 AWG) of type SPT-3, SPT-2W or greater and fixture wires as shown. Be careful to align the piece pins on the connector over the center of the wire connectors before tightening the screw. Any access fixture wire that sticks out the end of the Quick Connector should be cut off.
- 7) After all the fixtures are installed and connected to your low voltage cable, attach your main cable to the power pack and turn the unit on. If you have good connections, all of your cable, all of your light fixtures should be on.
- 8) To install, loosen ground with a shovel or soften soil with water, then press stake into ground. Do not use hammer. Do not push head of fixture to install stake into ground as it may break fixture.

The manufacturer warrants this lighting fixture to be free from defects in materials and workmanship for a period of two (2) years from date of purchase. This warranty applies only to the original consumer purchaser and only to products used in normal use and service. If this product is found to be defective, the manufacturer's only obligation, and your exclusive remedy, is the repair or replacement of the product at the manufacturer's discretion, provided that the product has not been damaged through misuse, abuse, accident, modifications, alterations, neglect or mishandling. This warranty shall not apply to any product that is found to have been improperly installed, set-up, or used in any way not in accordance with the instructions supplied with the product. This warranty shall not apply to a failure of the product as a result of an accident, misuse, abuse, negligence, alteration, or faulty installation, or any other failure not relating to faulty material or workmanship. This warranty shall not apply to the finish on any portion of the product, such as surface and/or weathering, as this is considered normal wear and tear. **The manufacturer does not warrant and specially disclaims any warranty, whether express or implied, of fitness for a particular purpose, other than the warranty contained herein. The manufacturer specifically disclaims any liability and shall not be liable for any consequential or incidental loss or damage, including but not limited to any labor / expense costs involved in the replacement or repair of said product.**

GARANTÍA LIMITADA

El fabricante garantiza que este accesorio de iluminación a estar libre de defectos en materiales y mano de obra durante un período de dos (2) años a partir de la fecha de compra. Esta garantía se aplica sólo al comprador original y sólo a los productos utilizados en condiciones normales de uso y servicio. Si se encuentra que este producto está defectuoso, la única obligación del fabricante, y su solución exclusiva, es la reparación o sustitución del producto, a discreción del fabricante, siempre que el producto no ha sido dañado por el mal uso, abuso, accidentes, modificaciones, alteraciones, negligencia o mal manejo. Esta garantía no se aplicará a cualquier producto que se demuestre que ha sido instalado incorrectamente, puesta a punto, o utilizado en cualquier manera no conforme con las instrucciones suministradas con el producto. Esta garantía no se aplicará a una falla del producto como consecuencia de un accidente, mal uso, abuso, negligencia, alteración o instalación defectuosa, o cualquier otro fallo que no se refieran a los materiales o ejecución defectuosa. Esta garantía no se aplicará a la meta en cualquier parte del producto, tales como la superficie y / o la intemperie, ya que se considera uso y desgaste normal.

El fabricante no garantiza y especialmente niega cualquier garantía, expresa o implícita, de aptitud para un propósito particular, excepto la garantía contenida en este documento. El fabricante rechaza específicamente cualquier responsabilidad y no será responsable por cualquier pérdida consecuente o incidental o daños, incluyendo pero no limitado a cualquier mano de obra Gastos de gastos que implica la sustitución o reparación de dicho producto.

GARANTIE LIMITÉE

Les garanties constructeur, ce montage doit être exempt de vices de matériaux et de fabrication pour une période de deux (2) ans à compter de la date d'achat. Cette garantie s'applique uniquement à l'acheteur initial et uniquement aux produits utilisés dans les conditions normales d'utilisation et de service. Si vous trouvez que ce produit est défectueux, la seule obligation du fabricant et votre recours exclusif, est la réparation ou le remplacement, à la discrétion du fabricant, à condition que le produit a été endommagé par un mauvais usage, d'abus, les accidents, modifications, altérations, d'une négligence ou une mauvaise manipulation. Cette garantie ne s'applique pas à un produit se trouve avoir été mal installés, set-up, ou utilisé d'une manière non conforme aux instructions livrées avec le produit. Cette garantie ne s'applique pas à une défaillance du produit résultant d'un accident, une mauvaise utilisation, abus, négligence, altération ou une mauvaise installation, ou tout autre manquement qui se rapportent à des matériaux ou d'exécution défectueuse. Cette garantie ne s'applique pas à l'objectif dans une partie quelconque du produit, tels que la surface et / ou des intempéries, telles que cela est considéré comme une usure normale. **Le fabricant ne garantit pas et décline notamment toute garantie, expresse ou implicite, d'adéquation à un usage particulier, sauf la garantie qui figure dans ce document. Le fabricant décline expressément toute responsabilité et ne saurait être tenue responsable pour tout dommage indirect ou accessoire ou des dommages, incluant mais non limité aux frais de main-d'oeuvre tous les coûts associés au remplacement ou la réparation du produit.**