

VENT FREE GAS LOG SET

Owner's Operation and Installation Manual Also Design Certified As Vented Decorative Appliances



American Elm Models

AEVF18FANG AEVF24FANG
AEVF18FALP AEVF24FALP

Fully Automatic Remote
Control Included



We recommend that our products be installed and serviced by professionals who are certified in the U.S. by NFI (National Fireplace Institute).

www.nficertified.org

WARNING: If the information in this manual is not followed exactly, a fire or explosion may result causing property damage, personal injury, or loss of life.

- Do not store or use gasoline or other flammable vapors and liquids in the vicinity of this or any other appliance.
- **WHAT TO DO IF YOU SMELL GAS**
 - Do not try to light any appliance.
 - Do not touch any electrical switch; do not use any phone in your building.
 - Immediately call your gas supplier from a neighbor's phone. Follow the gas supplier's instructions.
 - If you cannot reach your gas supplier, call the fire department.
- Installation and service must be performed by a qualified installer, service agency, or the gas supplier.

This is an unvented gas-fired heater. It uses air (oxygen) from the room in which it is installed. Provisions for adequate combustion and ventilation air must be provided. Refer to page 4, Air for Combustion and Ventilation.

INSTALLER: Leave this manual with the appliance.
CONSUMER: Retain this manual for future reference.

This appliance has been tested and approved under ANS Z21.11.2–2012 Unvented Gas-Fired Room Heaters.

WARNING: This appliance is for installation only in a solid fuel burning masonry or UL 127 factory-built fireplace or listed ventless firebox enclosure. It has been design certified for these installations. **EXCEPTION: DO NOT** install this appliance in a factory-built fireplace that includes instruction stating it has not been tested or should not be used with unvented gas logs.

This appliance may be installed in an aftermarket,* permanently located, manufactured (mobile) home, where not prohibited by local codes.

This appliance is only for use with the type of gas indicated on the rating plate. This appliance is not convertible for use with other gases.

* Aftermarket: Completion of sale, not for purpose of resale, from the manufacturer

TABLE OF CONTENTS

Safety Information	2
Local Codes	3
Unpacking	4
Product Features	4
Qualified Installation Agency	4
Air For Combustion and Ventilation	4
Installation	7
Operating Log Set	13
Inspecting Burners	15
Cleaning and Maintenance	16
Troubleshooting	17
Specifications	21
Parts List and Illustrated Parts Breakdown	22/23
Warranty Information	Back Cover

SAFETY INFORMATION

⚠ WARNING: Any change to this heater or its controls can be dangerous.

You must operate this heater with the fireplace screen in place. Make sure fireplace screen is closed before running appliance. Unless other provisions are made for combustion air, the screens shall have an opening or openings for intake of combustion air into the fireplace.

If this appliance is installed in a fireplace that has glass doors, the doors must be left open when the appliance is in use.

IMPORTANT: Read this owner's manual carefully and completely before trying to assemble, operate, or service this appliance. Improper use of this appliance can cause serious injury or death from burns, fire, explosion, electrical shock, and carbon monoxide poisoning.

WARNING: Improper installation, adjustment, alteration, service, or maintenance can cause injury or property damage. Refer to this manual for correct installation and operational procedures. For assistance or additional information consult a qualified installer, service agency, or the gas supplier.

⚠ DANGER: Carbon monoxide poisoning may lead to death!

Carbon Monoxide Poisoning: Early signs of carbon monoxide poisoning resemble the flu, with headaches, dizziness, or nausea. If you have these signs, the appliance may not be working properly. **Get fresh air at once!** Have appliance serviced. Some people are more affected by carbon monoxide than others. These include pregnant women, people with heart or lung disease or anemia, those under the influence of alcohol, and those at high altitudes.

Propane/LP Gas: Propane/LP gas is odorless. An odor-making agent is added to the gas. The odor helps you detect a gas leak. However, the odor added to the gas can fade. Gas may be present even though no odor exists.

Make certain you read and understand all warnings. Keep this manual for reference. It is your guide to safe and proper operation of this appliance.

⚠ WARNING: Do not use a blower insert, heat exchanger insert, or other accessory not approved for use with this appliance.

⚠ WARNING: Do not allow fans to blow directly into the appliance. Avoid any drafts that alter burner flame patterns. Ceiling fans can create drafts that alter burner flame patterns. Altered burner patterns can cause sooting.

Due to high temperatures, the appliance should be located out of traffic and away from furniture and draperies.

Do not place clothing or other flammable material on or near the appliance. Never place any objects on the heater.

Fireplace front and screen become very hot when running appliance. Keep children and adults away from hot surfaces to avoid burns or clothing ignition. Logs will remain hot for a time after shutdown. Allow surfaces to cool before touching.

Carefully supervise young children when they are in the room with fireplace.

⚠ WARNING: This product contains and/or generates chemicals known to the state of California to cause cancer or birth defects or other reproductive harm.

Keep the appliance area clear and free from combustible materials, gasoline, and other flammable vapors and liquids.

You must operate this heater with the fireplace screen in place. Make sure fireplace screen is closed before running appliance.

1. This appliance is only for use with the type of gas indicated on the rating plate. This appliance is not convertible for use with other gases.
2. Do not place propane/LP supply tank(s) inside any structure. Locate propane/LP supply tank(s) outdoors (propane/LP units only).
3. If you smell gas
 - shut off gas supply
 - do not try to light any appliance
 - do not touch any electrical switch; do not use any phone in your building
 - immediately call your gas supplier from a neighbor's phone. Follow the gas supplier's instructions
 - if you cannot reach your gas supplier, call the fire department
4. This appliance shall not be installed in a bedroom or bathroom.
5. Do not use this appliance as a wood-burning fireplace. Use only the logs provided with the appliance.
6. Do not add extra logs or ornaments such as pine cones, vermiculite or rock wool. Using these added items can cause sooting and poor combustion. Do not add lava rock around base. Rock and debris could fall into the control area of heater.
7. This appliance is designed to be smokeless. If logs ever appear to smoke, turn off appliance and call a qualified service person. Note: During initial operation, slight smoking could occur due to log curing and fireplace burning manufacturing residues.
8. To prevent the creation of soot, follow the instructions in Cleaning and Maintenance section.

Keep the appliance area clear and free from combustible materials, gasoline and other flammable vapors and liquids.
9. Before using furniture polish, wax, carpet cleaner, or similar products, turn heater off. If heated, the vapors from these products may create a white powder residue within burner box or on adjacent walls or furniture.
10. This appliance needs fresh air ventilation to run properly. This appliance has an Oxygen Depletion Sensing (ODS) safety shutoff system. The ODS shuts down the

fireplace if not enough fresh air is available. See Air for Combustion and Ventilation, pages 4 through 6. If appliance keeps shutting off, see Troubleshooting, pages 17 through 20.

11. Do not run appliance:
 - where flammable liquids or vapors are used or stored
 - under dusty conditions
12. Do not use this appliance to cook food or burn paper or other objects.
13. Never place any objects in the heater or on logs.
14. Do not use appliance if any part has been exposed to or under water. Immediately call a qualified service technician to inspect the appliance and to replace any part of the control system and any gas control which has been under water.
15. Turn appliance off and let cool before servicing. Only a qualified service person should service and repair appliance.
16. Operating appliance above elevations of 4,500 feet could cause pilot outage.
17. To prevent performance problems, do not use propane/LP fuel tanks of less than 100 lbs. capacity.
18. Provide adequate clearances around air openings.

LOCAL CODES

Install and use appliance with care. Follow all local codes. In the absence of local codes, use the latest edition of The National Fuel Gas Code ANSI Z223.1/NFPA 54*.

*Available from:

American National Standards Institute, Inc.
1430 Broadway
New York, NY 10018

National Fire Protection Association, Inc.
Batterymarch Park
Quincy, MA 02269

State of Massachusetts: The installation must be made by a licensed plumber or gas fitter in the Commonwealth of Massachusetts.

Sellers of unvented propane or natural gas-fired supplemental room heaters shall provide to each purchaser a copy of 527 CMR 30 upon sale of the unit.

Vent-free gas products are prohibited for bedroom and bathroom installation in the Commonwealth of Massachusetts.

UNPACKING

1. Remove the carton and log wrap.
2. Remove all protective packaging applied to heater for shipment.
3. Make sure your logset includes one hardware packet.
4. Check heater for any shipping damage. If heater is damaged, call SHM International at (800) 229-5647 for replacement parts before returning to dealer.

PRODUCT FEATURES

SAFETY PILOT

This heater has a pilot with an Oxygen Depletion Sensing (ODS) safety shutoff system. The ODS/pilot is a required feature for vent-free room heaters. The ODS/pilot shuts off the heater if there is not enough fresh air.

PIEZO IGNITION SYSTEM

This heater has a piezo ignitor. This system requires no matches, batteries or other sources to light heater.

REMOTE CONTROL OPERATION THERMOSTATIC HEAT CONTROL

This unit is supplied with a hand held remote control. It can be used to turn the log set on and off. The thermostat setting can also be selected. Thermostat setting sense the room temperature at the location of the remote handset. The thermostat will automatically turn the unit on and off to maintain a consistent room temperature. This results in greater heater comfort. This can also result in lower gas bills.

QUALIFIED INSTALLATION AGENCY

Installation and replacement of gas piping, gas utilization equipment or accessories and repair and servicing of equipment shall be performed only by a qualified agency. The term "qualified agency" means any individual, firm, corporation, or company that either in person or through a representative is engaged in and is responsible for:

- A. Installation, testing or replacements of gas piping or
- B. Connection, installation, testing, repair or servicing of equipment that is experienced in such work; that is familiar with all precautions required; and that has complied with all requirements of the authority having jurisdiction.

AIR FOR COMBUSTION AND VENTILATION

⚠ WARNING: This heater shall not be installed in a room or space unless the required volume of indoor combustion air is provided by the method described in the National Fuel Gas Code, ANSI Z223.1/NFPA 54, the International Fuel Gas Code, or applicable local codes.

Read the following instructions to insure proper fresh air for this and other fuel-burning appliances in your home.

Today's homes are built more energy efficient than ever. New materials, increased insulation, and new construction methods help reduce heat loss in homes. Home owners weather strip and caulk around windows and doors to keep the cold air out and the warm air in. During heating months, home owners want their homes as airtight as possible.

While it is good to make your home energy efficient, your home needs to breathe. Fresh air must enter your home. All fuel-burning appliances need fresh air for proper combustion and ventilation.

Exhaust fans, fireplaces, clothes dryers, and fuel burning appliances draw air from the house to operate. You must provide adequate fresh air for these appliances. This will insure proper venting of vented fuel-burning appliances.

PROVIDING ADEQUATE VENTILATION

The following are excerpts from National Fuel Gas Code ANSI Z223.1/NFPA 54, Section 5.3, Air for Combustion and Ventilation.

All spaces in homes fall into one of the three following ventilation classifications:

1. Unusually Tight Construction
2. Unconfined Space
3. Confined Space

The information on pages 4 through 6 will help you classify your space and provide adequate ventilation.

Unusually Tight Construction

The air that leaks around doors and windows may provide enough fresh air for combustion and ventilation. However, in buildings of unusually tight construction, you must provide additional fresh air.

Unusually tight construction is defined as construction where:

- walls and ceilings exposed to the outside atmosphere have a continuous water vapor retarder with a rating of one perm (6×10^{-11} kg per pa-sec- m^2) or less with openings gasketed or sealed and
- weather stripping has been added on openable windows and doors and
- caulking or sealants are applied to areas such as joints around window and door frames, between sole plates and floors, between wall-ceiling joints, between wall panels, at penetrations for plumbing, electrical, and gas lines, and at other openings.

If your home meets all of the three criteria above, you must provide additional fresh air. See *Ventilation Air From Outdoors*, page 5.

If your home does not meet all of the three criteria above, proceed to *Determining Fresh-Air Flow for Appliance Location*, page 6.

VENTILATION AIR

Ventilation Air From Inside Building

This fresh air would come from an adjoining unconfined space. When ventilating to an adjoining unconfined space, you must provide two permanent openings: one within 12" of the ceiling and one within 12" of the floor on the wall connecting the two spaces (see Figure 1). You can also remove door into adjoining room (see Figure 1). Follow the National Fuel Gas Code ANSI Z223.1/NFPA 54, Section 5.3, Air for Combustion and Ventilation for required size of ventilation grills or ducts.

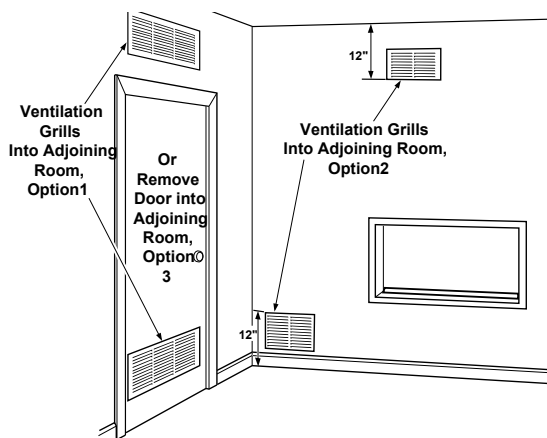

Figure 1 - Ventilation Air from Inside Building

Ventilation Air From Outdoors

Provide extra fresh air by using ventilation grills or ducts. You must provide two permanent openings: one within 12" of the ceiling and one within 12" of the floor. Connect these items directly to the outdoors or spaces open to the outdoors. These spaces include attics and crawl spaces. Follow the *National Fuel Gas Code ANSI Z223.1/NFPA 54, Section 5.3, Air for Combustion and Ventilation* for required size of ventilation grills or ducts.

IMPORTANT: Do not provide openings for inlet or outlet air into attic if attic has a thermostat-controlled power vent. Heated air entering the attic will activate the power vent.

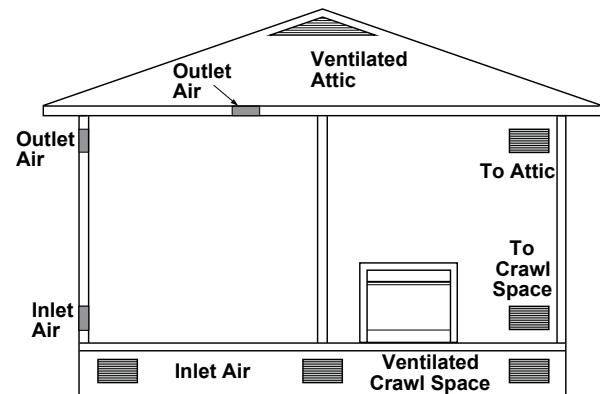

Figure 2 - Ventilation Air from Outdoors

AIR FOR COMBUSTION AND VENTILATION

Continued

DETERMINING FRESH-AIR FLOW FOR APPLIANCE LOCATION

Determining if You Have a Confined or Unconfined Space

Use this work sheet to determine if you have a confined or unconfined space.

Space: Includes the room in which you will install appliance plus any adjoining rooms with doorless passageways or ventilation grills between the rooms.

1. Determine the volume of the space (length x width x height).

Length x Width x Height = cu. ft. (volume of space)

Example: Space size 22 ft. (length) x 18 ft. (width) x 8 ft. (ceiling height) = 3168 cu. ft. (volume of space)

If additional ventilation to adjoining room is supplied with grills or openings, add the volume of these rooms to the total volume of the space.

2. Multiply the space volume by 20 to determine the maximum Btu/Hr the space can support.

_____ (volume of space) x 20 = (Maximum Btu/Hr the space can support)

Example: 3168 cu. ft. (volume of space) x 20 = 63,360 (maximum Btu/Hr the space can support)

3. Add the Btu/Hr of all fuel burning appliances in the space.

Vent-free log set _____	Btu/Hr
Gas water heater* _____	Btu/Hr
Gas furnace _____	Btu/Hr
Vented gas heater _____	Btu/Hr
Gas fireplace logs _____	Btu/Hr
Other gas appliances* + _____	Btu/Hr
Total = _____	Btu/Hr

* Do not include direct-vent gas appliances. Direct-vent draws combustion air from the outdoors and vents to the outdoors.

Example:

Vent-free log set _____	39,000	Btu/Hr
Gas water heater* _____	40,000	Btu/Hr
Total = _____	79,000	Btu/Hr

4. Compare the maximum Btu/Hr the space can support with the actual amount of Btu/Hr used.

_____ Btu/Hr (max. the space can support)

_____ Btu/Hr (actual amt. of Btu/Hr used)

Example: 63,300 Btu/Hr (maximum the space can support)

73,000 Btu/Hr (actual amount of Btu/Hr used)

The space in the above example is a confined space because the actual Btu/Hr used is more than the maximum Btu/Hr the space can support. You must provide additional fresh air. Your options are as follows:

- A. Rework work sheet, adding the space of an adjoining room. If the extra space provides an unconfined space, remove door to adjoining room or add ventilation grills between rooms. See *Ventilation Air from Inside Building*, page 5.
- B. Vent room directly to the outdoors. See *Ventilation Air from Outdoors*, page 5.
- C. Install a lower Btu/Hr appliance, if lower Btu/Hr size makes room unconfined.

If the actual Btu/Hr used is less than the maximum Btu/Hr the space can support, the space is an unconfined space. You will need no additional fresh air ventilation.

⚠ WARNING: If the area in which the heater may be operated is smaller than that defined as an unconfined space or if the building is of unusually tight construction, provide adequate combustion and ventilation air by one of the methods described in the National Fuel Gas Code, ANSI Z223.1/ NFPA 54, Air for Combustion and Ventilation, or applicable local codes.

INSTALLATION

⚠ WARNING: Before installing in a solid-fuel-burning fireplace, the chimney flue and firebox must be cleaned of soot, creosote, ashes, and loose paint by a qualified chimney cleaner.

NOTICE: This appliance is intended for supplemental heating. Use this heater along with your primary heating system. Do not install this heater as your primary heat source. If you have a central heating system, you may run system's circulating blower while using heater. This will help circulate the heat throughout the house. In the event of a power outage, you can use this heater as your primary heat source.

⚠ WARNING: A qualified service person must install appliance. Follow all local codes.

⚠ WARNING: Never install the appliance

- in a recreational vehicle
- where curtains, furniture, clothing, or other flammable objects are less than 36 inches (91.5 cm) from the front, top, or sides of the appliance
- in a wood-burning stove
- in high-traffic areas
- in windy/drafty areas

⚠ WARNING: Never install in a bedroom or bathroom. Any heating product with a Btu/Hr rating over 10,000 cannot be used in a bedroom. Any heating product with a Btu/Hr rating over 6,000 cannot be used in a bathroom.

⚠ CAUTION: This appliance creates warm air currents. These currents move heat to wall surfaces next to appliance. Installing appliance next to vinyl or cloth wall coverings or operating appliance where impurities (such as tobacco smoke, aromatic candles, cleaning fluids, oil or kerosene lamps, etc.) in the air exist, may discolor walls.

IMPORTANT: Vent-free heaters add moisture to the air. Although this is beneficial, installing appliance in rooms without enough ventilation air may cause mildew to form from too much moisture. See Air for Combustion and Ventilation, page 4.

CHECK GAS TYPE

Use the correct gas type (natural or propane/LP) for your appliance. If your gas supply is not correct or if you do not know your gas type, do not install appliance.

INSTALLATION ITEMS NEEDED

Before installing appliance, make sure you have the items listed below.

- external regulator for propane/LP unit only (supplied by installer)
- piping (check local codes)
- sealant (resistant to propane/LP gas)
- equipment shutoff valve *
- test gauge connection *
- ground joint union (if required)
- sediment trap (suggested)
- tee joint
- pipe wrench
- approved flexible gas line connector (if allowed by local codes) (not provided)

* A CSA/AGA design-certified equipment shutoff valve with 1/8" NPT tap is an acceptable alternative to test gauge connection. Purchase the optional CSA/AGA design-certified equipment shutoff valve from your dealer.

For propane/LP units, the installer must supply an external regulator. The external regulator will reduce incoming gas pressure. You must reduce incoming gas pressure to between 11 and 14 inches of water. If you do not reduce incoming gas pressure, heater regulator damage could occur.

LOG SET PLACEMENT

Place the log set burner system in the center of your fireplace or fire box. Ensure enough space around the logs for air circulation. If the fireplace (or firebox) is too small for the logs, do not install.

INSTALLATION

Continued

INSTALLATION CLEARANCES

⚠ WARNING: Maintain the minimum clearances.

Mantel Clearances for Installation

If placing mantel above heater, you must meet the minimum clearance between the mantel shelf and the top of the firebox opening.

NOTICE: Surface temperatures of adjacent walls and mantels become hot during operation. Walls and mantels above the firebox may become hot to the touch. If installed properly, these temperatures meet the requirement of the national product standard. Follow all minimum clearances shown in this manual.

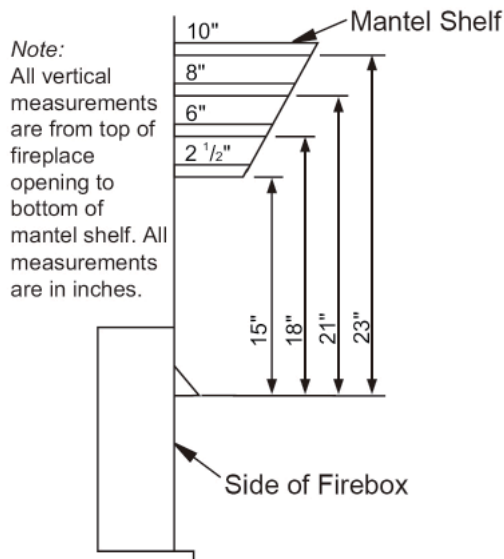

Figure 11-Minimum Mantel Clearances for Installation

CONNECTING TO GAS SUPPLY

⚠ WARNING: A qualified service person must connect log set to gas supply. Follow all local codes.

⚠ WARNING: Never connect natural gas log set to private (non-utility) gas wells. This gas is commonly known as wellhead gas.

IMPORTANT: For natural gas, check gas line pressure before connecting heater to gas line. Gas line pressure must be no greater than 10.5" of water. If gas line pressure is higher, heater regulator damage could occur.

⚠ CAUTION: Never connect propane/LP log set directly to the propane/LP supply. This appliance requires an external regulator (not supplied). Install the external regulator between the appliance and propane/LP supply.

For propane/LP gas, the installer must supply an external regulator. The external regulator will reduce incoming gas pressure. You must reduce incoming gas pressure to between 11" and 14" of water. If you do not reduce incoming gas pressure, heater regulator damage could occur. Install the external regulator with the vent pointing down as shown in Figure 12. Pointing the vent down protects it from freezing rain or sleet.

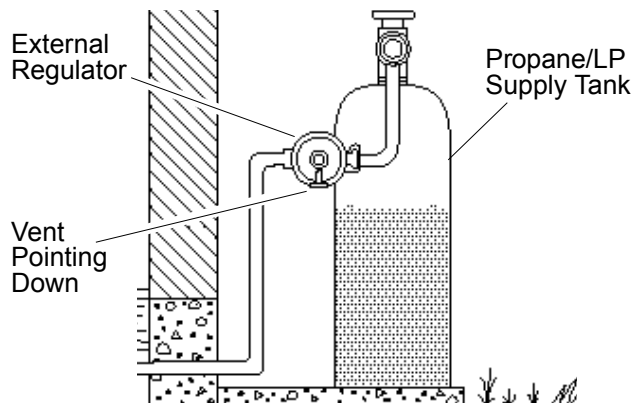

Figure 12 - External Regulator with Vent Pointing Down

⚠ CAUTION: Use only new, black iron or steel pipe. Internally-tinned copper tubing may be used in certain areas. Check your local codes. Use pipe of 1/2" diameter or greater to allow proper gas volume to appliance. If pipe is too small, undue loss of pressure will occur.

Shutoff Valve

Installation must include an equipment shutoff valve, union, and plugged 1/8" NPT tap. Locate NPT tap within reach for test gauge hook up. NPT tap must be upstream from appliance.

IMPORTANT: Install equipment shutoff valve in an accessible location. The equipment shutoff valve is for turning on or shutting off the gas to the appliance.

Check your building codes for any special requirements for locating equipment shutoff valve to fireplaces.

Apply pipe joint sealant lightly to male NPT threads. This will prevent excess sealant from going into pipe. Excess sealant in pipe could result in clogged fireplace valves. Never use sealant on flare threads.

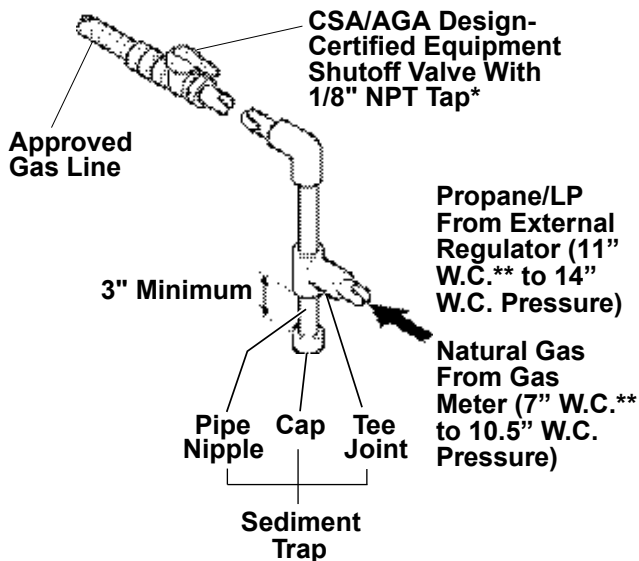

Figure 13 - Gas Connection

* Purchase the optional CSA/AGA design-certified equipment shutoff valve from your dealer.

** Minimum inlet pressure for purpose of input adjustment.

⚠ CAUTION: Use pipe joint sealant that is resistant to liquid petroleum (LP) gas.

We recommend that you install a sediment trap in supply line as shown in Figure 6. Locate sediment trap where it is within reach for cleaning. Install in piping system between fuel supply and appliance. Locate sediment trap where trapped matter is not likely to freeze. A sediment trap traps moisture and contaminants. This keeps them from going into appliance gas controls. If sediment trap is not installed or is installed wrong, appliance may not run properly.

CHECKING GAS CONNECTIONS

⚠ WARNING: Test all gas piping and connections, internal and external to unit, for leaks after installing or servicing. Correct all leaks at once.

⚠ WARNING: Never use an open flame to check for a leak. Apply a mixture of liquid soap and water to all joints. Bubbles forming show a leak. Correct all leaks at once.

Pressure Testing Gas Supply Piping System

Test Pressures In Excess Of 1/2 PSI (3.5 kPa)

1. Disconnect appliance with its main gas valve (control valve) and equipment shutoff valve from gas supply piping system. Pressures in excess of 1/2 psi will damage appliance gas regulator.
2. Cap off open end of gas pipe where equipment shutoff valve was connected.
3. Pressurize supply piping system by either opening propane/LP supply tank valve for propane/LP gas or opening main gas valve located on or near gas meter of natural gas or using compressed air.
4. Check all joints of gas supply piping system. Apply noncorrosive leak detection fluid to all joints. Bubbles forming show a leak.
5. Correct all leaks at once.
6. Reconnect appliance and equipment shutoff valve to gas supply. Check reconnected fittings for leaks.

INSTALLATION

Continued

Test Pressures Equal To or Less Than 1/2 PSIG (3.5 kPa)

1. Close equipment shutoff valve (see Figure 14).
2. Pressurize supply piping system by either opening propane/LP supply tank valve for propane/LP gas or opening main gas valve located on or near gas meter of natural gas or using compressed air.
3. Check all joints from gas meter to equipment shutoff valve for natural gas or propane/LP supply to equipment shutoff valve for propane/LP. Apply noncorrosive leak detection fluid to all joints. Bubbles forming show a leak.
4. Correct all leaks at once.

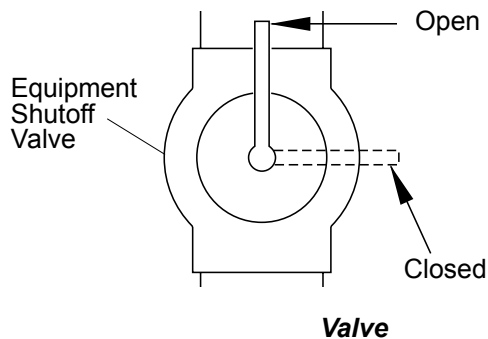

Figure 14 - Equipment Shutoff Valve

PRESSURE TESTING APPLIANCE GAS CONNECTIONS

1. Open equipment shutoff valve (see Figure 14).
2. For natural gas, open main gas valve located on or near gas meter. For propane/LP gas, open propane/LP supply tank valve.
3. Make sure control knob of fireplace is in the OFF position.
4. Check all joints from equipment shutoff valve to gas control valve. Apply noncorrosive leak detection fluid to all joints. Bubbles forming show a leak.
5. Correct all leaks at once.
6. Light fireplace (see *Operating Log Set*, page 13). Check all other internal joints for leaks.
7. Turn off fireplace (see *To Turn Off Gas To Log Set*, page 14).

BATTERY INSTALLATION

Batteries must be installed in the appliance for it to function. There are four “C”-cells in the burner system, and two “AAA” cells in the handset.

BURNER SYSTEM

1. Remove the two phillips screws at each side of the battery holder and remove holder. Be careful with the attached wires. (see figure 15)
2. install batteries into the holder, minding the polarity of each cell.
3. carefully reinstall the battery holder into the burner system, again minding the wires.
4. Replace the two screws.

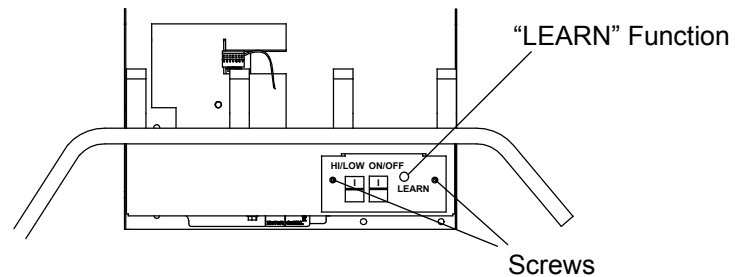

Figure 15 - Burner System switches and Battery location

HANDSET

1. On the back of the handset, slide the battery cover down and off.
2. Install two “AAA” cells (mind the polarity).
3. replace cover.

USING THE “LEARN” FUNCTION

To program your burner system to accept commands from your handset, the “LEARN” function (see figure 15) is used.

1. Press and release the learn switch to open the LEARN window, the module will beep indicating the module is ready to accept a transmitter security code.
2. Press a transmitter button to send any command, the module will generate a series of beeps indicating a signal was received.
 - The LEARN window will remain open for 60-seconds.
 - The control will learn up to 3 different transmitter security codes.

Log Placement - American Elm 18" Models

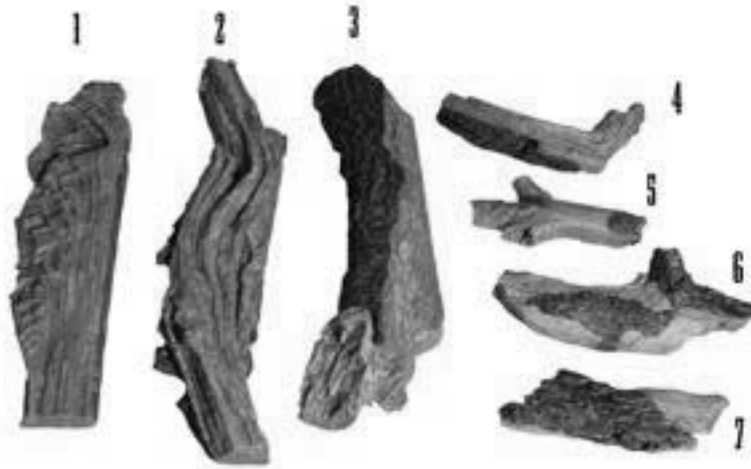

Log Placement - American Elm 24" Models

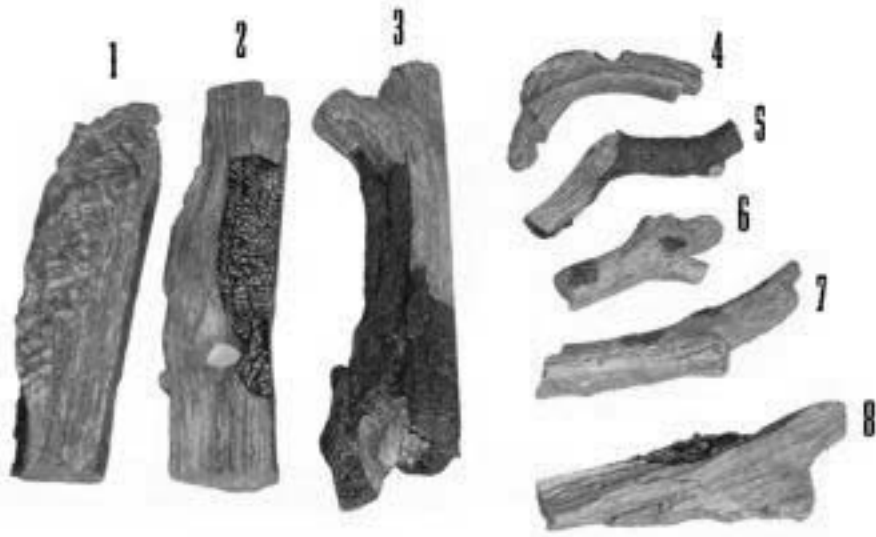

OPERATING LOG SET

FOR YOUR SAFETY READ BEFORE OPERATING

⚠ WARNING: If you do not follow these instructions exactly, a fire or explosion may result causing property damage, personal injury or loss of life.

- A. This appliance is equipped with an ignition device which automatically lights the pilot. **Do Not** try to light the pilot by hand.
- B. BEFORE LIGHTING smell all around the appliance area for gas. Be sure to smell next to the floor because some gas is heavier than air and will settle on the floor.
WHAT TO DO IF YOU SMELL GAS
 - Do not try to light any appliance.
 - Do not touch any electric switch; do not use any phone in your building.
 - Immediately call your gas supplier from a neighbor's phone. Follow the gas supplier's instructions.
 - If you cannot reach your gas supplier, call the department.
- C. Main gas valve in this appliance is not serviceable and does not have any control knobs or switches to operate. Do not remove heat shields covering the valve and electronic devices; do not try to repair or modify the valve as it may result in a fire or explosion. Call a qualified service technician if you have any safety concerns.
- D. Do not use this appliance if any part has been under water. Immediately call a qualified service technician to inspect the appliance and to replace any part of the control system and any gas control which has been under water.

IPI/CPI SWITCH

The burner system can be operated in either IPI (intermittent Pilot Ignition) or CPI (continues Pilot Ignition) modes. In IPI mode the pilot lights each time the burner system is operated. In CPI mode the ODS Pilot stays on and the burner is turned ON and OFF with the switch or remote handset. The IPI/CPI switch is on the right side of the burner system, near the front log.

OPERATING INSTRUCTIONS

1. **STOP!** Read the safety information, starting on page 2.
2. Turn off all electric power to the appliance.
3. Do not attempt to light the pilot by hand.
4. Turn main shutoff valve counterclockwise  to the ON position.
5. Set Burner System Receiver switch to OFF position.
7. Locate Burner System controls on the right front (see **Figure 15**, page 12. Make sure that the ON/OFF switch for the burner is in the OFF position. (see **Figure 9a**)

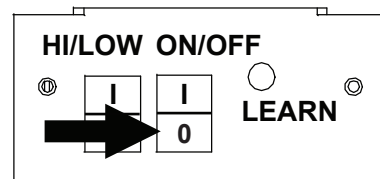

Figure 9a - Burner System Receiver Switch in OFF Position

8. Wait five (5) minutes to clear out any gas. Then smell for gas, including near the floor. If you smell gas, **STOP!** Follow "B" in the safety information. If you don't smell gas, go to the next step.
Note: Before applying any power supply to the Module board, please verify that the electrical connections are in accordance to the **Wiring Diagram** Figure 24, page 21.

Initializing the System for the First Time (IPI/CPI Switch In IPI Position)

1. Set the ON/OFF switch to the ON position. (See Figure 9b)

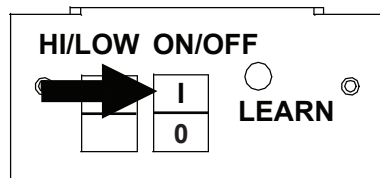

Figure 9b - Burner System Switch in ON Position

The unit will proceed to ignite the pilot, and then the main burner and will operate in the HIGH setting. If the appliance will not operate, follow the instructions "To Turn Off Gas To Appliance" and call your service technician or gas supplier.

OPERATING LOG SET

Continued

Initializing the System for the First Time (IPI/CPI Switch In IPI Position)

1. Set the IPI/CPI pilot mode switch to the CPI position (switch closed). At that point the unit will immediately ignite the pilot flame. The pilot flame will remain ON.

Note: If pilot does not stay lit, contact a qualified service person or gas supplier for repairs.

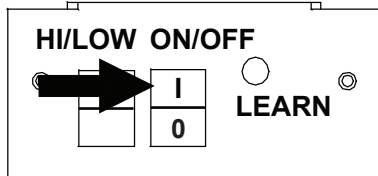

Figure 18 - Remote Receiver Switch in ON Position

Turning ON the Appliance

1. Press the Burner System ON/OFF switch into the ON position. This will cause the main burner to ignite.
2. Set flame to high or low setting with HI/LOW switch or HI/MED/LOW with remote handset.

Turning OFF the Appliance

1. Slide the remote receiver switch to the OFF position. This will turn off the main burner.

Note: If the **Continuous Pilot Ignition** mode is selected the pilot flame will remain **ON**. To turn the pilot flame completely **OFF**, switch the appliance into **Intermittent Pilot Ignition** mode and set the **IPI/CPI** pilot mode switch to the **IPI** position (switch opened).

Note: You may be running this heater for the first time after hooking up to gas supply. If so, the control switch may need to be pressed in more than one time. This will allow air to bleed from the gas system.

CAUTION: Do not try to adjust heating levels by using the equipment shutoff valve.

WARNING: Make sure the remote handset switch is in the OFF position when you are away from home for long periods of time. Heater may come on automatically with remote receiver switch in the "THERMOSTAT" position.

TO TURN OFF GAS TO APPLIANCE

1. Turn off all electric power to the appliance (remove batteries) if service is to be performed.

3. Turn the main manual gas valve clockwise to the full OFF position.



Command Definitions

Pilot IPI/CPI Switch	System ON/OFF Switch	Command Name	Burner System State
Opened, IPI		Turn-OFF	Flames OFF
Opened, IPI	Closed	Turn-ON	Pilot & Main Burner Flames ON
Closed, CPI	Opened	Pilot-ON	Pilot Flame ON
Closed, CPI	Closed	Turn-ON	Pilot & Main Burner Flames ON

REMOTE CONTROL OPERATION

Initializing the System for the First Time

Follow instructions under *USING THE LEARN FUNCTION, Page 10*

KEY SETTINGS

1. **ON** - Turns appliance on
2. **OFF** - Turns appliance off
3. **MODE** Cycles control between manual and thermostat mode.
4. **SET** - Sets temperature in thermostat mode.

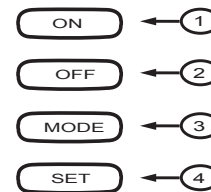

Figure 19 - Remote Handset Switch Functions

To Turn Burner ON

Press the **ON** key to turn the appliance on. (The flame icon will appear on the LCD screen).

To Turn Burner OFF

Press the **OFF** key to turn the appliance off. (The flame icon will disappear from the LCD screen).

THERMOSTAT FUNCTION

Press the **MODE** key until the LCD screen shows the word "ROOM." To adjust set temperature, press and hold the **SET** key until the desired temperature is reached. The temperature range is 99°F (32°C) to 45°F (6°C).

The LCD screen will display the set temperature for 3 seconds, then it will flash the set temperature for 3 seconds. It will default to show the room temperature. The flame icon will appear when the control calls for heat.

The flame icon will disappear when the appliance reaches its set temperature.

REMOTE CONTROL OPERATION

Continued

Press the **MODE** key to disengage the Thermostat. “ROOM” will disappear from the LCD screen.

CP (CHILDPROOF) or LOCK FEATURE

This remote control includes a childproof feature that allows the user to “lock-out” operations from the transmitter. To activate and de-activate the childproof feature, press and hold the **MODE** button and the **ON** button at the same time for 5 seconds. The letters “CP” will briefly appear on the LCD screen when childproof mode is activated.

- “CP” will appear on the LCD screen if any button is pressed while childproof mode is engaged.
- When this mode is engaged, all auto settings go on without interruption (like thermostat). Only manual functions are prevented.

INSPECTING BURNERS

Check pilot flame pattern and burner flame patterns often.

PILOT FLAME PATTERN

Figure 19 shows a correct pilot flame pattern. Figure 20 shows incorrect pilot flame patterns. The incorrect pilot flames are not touching the flame sensor. This will cause the flame sensor to cool. When the flame sensor cools, the appliance will shut down.

If pilot flame pattern is incorrect, as shown in Figure 21

- turn heater off (see *To Turn Off Gas To Appliance*, page 14)
- see *Cleaning and Maintenance*, page 16

Note: The correct pilot flame on natural gas units will have a slight curve, but flame should be blue and have no yellow or orange color. There should be no sooting.

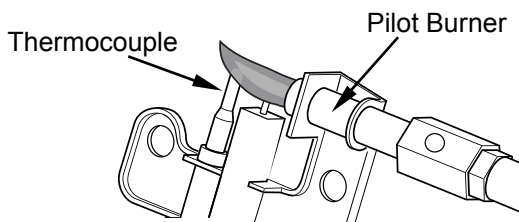

Figure 19 - Correct Pilot Flame Pattern

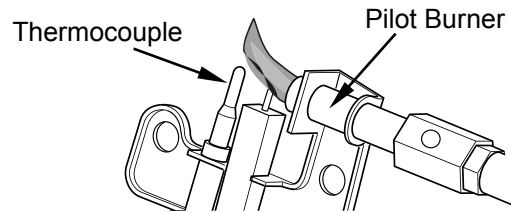

Figure 20 - Incorrect Pilot Flame Pattern

BURNER FLAME PATTERN

WARNING: If yellow tipping occurs, your heater could produce increased levels of carbon monoxide.

NOTICE: Do not mistake orange flames with yellow tipping. Dirt or other fine particles enter the heater and burn, causing brief patches of orange flame.

Figure 23 shows correct burner flame pattern. Figure 24 shows incorrect burner flame patterns. The incorrect burner flame patterns show sporadic, irregular flame tipping. The flame should not be dark or have an orange/reddish tinge.

Note: When using the appliance for the first time, the flame will be orange for approximately one hour until the logs cure.

If burner flame pattern is incorrect, as shown in Figure 24

- turn heater off (see *To Turn Off Gas To Log Set*, page 14)
- see Troubleshooting, pages 17 through 20

If burner flame pattern is incorrect, as shown in Figure 23, you should

- turn heater off (see *To Turn Off Gas To Appliance*, page 14)
- Refer to Troubleshooting (page 17) or call a qualified service person to resolve any operational issues



Figure 21 - Correct Burner Flame Pattern



Figure 22 - Incorrect Burner Flame Pattern

continued

CLEANING AND MAINTENANCE

⚠ WARNING: Turn off appliance and let cool before cleaning.

⚠ CAUTION: Keep burner and control compartment clean. See installation and operating instructions accompanying heater. Inspect these areas of fireplace before each use. Have fireplace inspected yearly by a qualified service person. Fireplace may need more frequent cleaning due to excessive lint from carpeting, bedding material, pet hair, etc.

⚠ WARNING: Failure to keep the primary air opening of the burner clean may result in sooting and property damage.

BURNER INJECTOR HOLDER AND PILOT AIR INLET HOLE

The primary air inlet holes allow the proper amount of air to mix with the gas. This provides a clean burning flame. Keep these holes clear of dust, dirt, lint, and pet hair. Blocked air holes will create soot. We recommend that you clean the unit every three months during operation and have heater inspected yearly by a qualified service person.

We also recommend that you keep the burner tube and pilot assembly clean and free of dust and dirt. To clean these parts we recommend using compressed air no greater than 30 PSI. Your local computer store, hardware store, or home center may carry compressed air in a can. You can use a vacuum cleaner in the blow position. If using compressed air in a can, please follow the directions on the can. If you don't follow directions on the can, you could damage the pilot assembly.

1. Shut off the unit, including the pilot. Allow the unit to cool for at least 30 minutes.
2. Inspect burner, pilot, and primary air inlet holes on injector holder for dust and dirt (see Figures 23 and 24).
3. Blow air through the ports/slots and holes in the burner.
4. Check the injector holder located at the end of the burner tube again. Remove any large particles of dust, dirt, lint, or pet hair with a soft cloth or vacuum cleaner nozzle.
5. Blow air into the primary air holes on the injector holder.

6. In case any large clumps of dust have now been pushed into the burner repeat steps 3 and 4.

Clean the pilot assembly also. A yellow tip on the pilot flame indicates dust and dirt in the pilot assembly. There is a small pilot air inlet hole about two inches from where the pilot flame comes out of the pilot assembly (see Figure 23). With the unit off, lightly blow air through the air inlet hole. You may blow through a drinking straw if compressed air is not available.

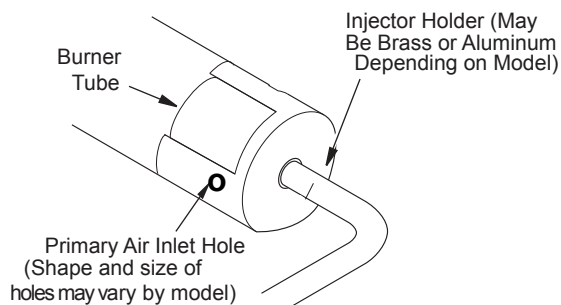

Figure 23 - Injector Holder On Outlet Burner Tube

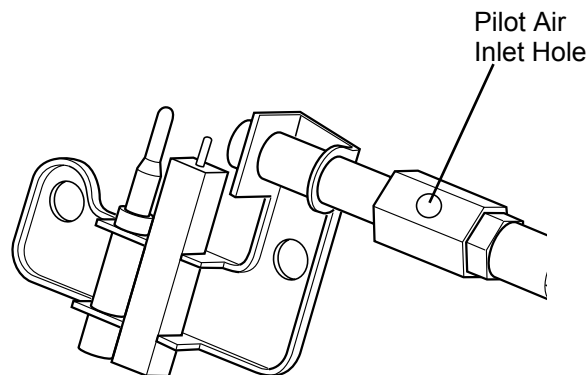

Figure 24 - Pilot Inlet Air Hole

LOG REMOVAL

If you remove logs for cleaning, be sure and follow the instructions under *Log Placement*, page 11 to correctly replace logs. Be sure and replace any broken logs before operating appliance.

Replace any screen or guard (heat shield or cover Before operating the appliance.

TROUBLESHOOTING

⚠ WARNING: Turn off heater and let cool before servicing. Only a qualified service person should service and repair heater.

⚠ CAUTION: Never use a wire, needle, or similar object to clean ODS/pilot. This can damage ODS/pilot unit.

Note: All troubleshooting items are listed in order of operation.

OBSERVED PROBLEM	POSSIBLE CAUSE	REMEDY
When ON button or remote button is pressed, there is no spark at ODS pilot	<ol style="list-style-type: none"> 1. Ignitor electrode not connected to ignitor cable 2. Ignitor cable pinched or wet 3. Broken ignitor cable 4. Bad ignitor 5. Ignitor electrode broken 6. Ignitor electrode positioned wrong 	<ol style="list-style-type: none"> 1. Reconnect ignitor cable 2. Free ignitor cable if pinched by any metal or tubing. Keep ignitor cable dry 3. Replace ignitor cable 4. Call for service 5. Replace pilot assembly 6. Replace pilot assembly
When ON button or remote button is pressed, there is spark at ODS pilot but no ignition	<ol style="list-style-type: none"> 1. Gas supply turned off or equipment shutoff valve closed 2. Air in gas lines when installed 3. Depleted gas supply 4. ODS/pilot is clogged 5. Gas regulator setting is not correct 	<ol style="list-style-type: none"> 1. Turn on gas supply or open equipment shutoff valve 2. Continue holding down control knob. Repeat igniting operation until air is removed 3. Contact local propane/LP gas company 4. Clean ODS/pilot (see Cleaning and Maintenance, page 16) or replace ODS/pilot assembly 5. Replace gas control
Pilot light stays on when main burner is turned OFF	<ol style="list-style-type: none"> 1. IPI/CPI switch (on right side of chassis) in wrong position 	<ol style="list-style-type: none"> 1. Check toggle switch on right side of chassis. Make sure switch is in IPI position

TROUBLESHOOTING

continued

OBSERVED PROBLEM	POSSIBLE CAUSE	REMEDY
<p>ODS/pilot lights but flame goes out</p>	<ol style="list-style-type: none"> 1. Equipment shutoff valve not fully open 2. Thermocouple connection loose as control valve 3. Pilot flame not touching thermocouple, which allows thermocouple to cool, causing pilot flame to go out. This problem could be caused by one or both of the following: <ul style="list-style-type: none"> A) Low gas supply B) Dirty or partially clogged ODS/pilot 4. Thermocouple Connection loose 5. Thermocouple Bad/Damaged 6. Control valve damaged 7. Safety interlock system has been triggered 	<ol style="list-style-type: none"> 1. Fully open equipment shut-off valve 2. Hand tighten until snug, then tighten 1/4 turn more 3. A) Contact local natural or propane/LP gas company B) Clean ODS/pilot (see Cleaning and Maintenance, page 16) 4. Tighten thermocouple (finger tight plus 1/4 turn) 5. Replace pilot assembly 6. Replace control valve 7. Wait one minute for the safety interlock system to reset. Repeat ignition operation
<p>Burner does not light after ODS/pilot is lit</p>	<ol style="list-style-type: none"> 1. Burner orifice(s) is clogged 2. Inlet gas pressure is too low 3. Leads disconnected from valve or module board 	<ol style="list-style-type: none"> 1. Clean burner orifice (see Cleaning and Maintenance, page 16) or replace burner orifice 2. Contact local natural or propane/LP gas company 3. Verify all plugs are firmly connected to their mating points
<p>Burner cycles on and off - Unit makes 2 "beeps" every second</p>	<ol style="list-style-type: none"> 1. unstable pilot due to drafts or air currents 	<ol style="list-style-type: none"> 1. make sure no fans or air currents are blowing into fireplace
<p>Delayed ignition of burner</p>	<ol style="list-style-type: none"> 1. Manifold pressure is too low 2. Burner orifice(s) clogged 	<ol style="list-style-type: none"> 1. Contact local natural or propane/LP gas company 2. Clean burner (see Cleaning and Maintenance, page 16) or replace burner orifice
<p>Burner backfiring during combustion</p>	<ol style="list-style-type: none"> 1. Burner orifice(s) is clogged or damaged 2. Damaged burner 3. Gas regulator defective 4. Inlet gas pressure is too low 	<ol style="list-style-type: none"> 1. Clean burner (see Cleaning and Maintenance, page 16) or replace burner orifice 2. Replace damaged burner 3. Replace gas regulator 4. Contact local natural gas or propane/LP company

TROUBLESHOOTING

continued

OBSERVED PROBLEM	POSSIBLE CAUSE	REMEDY
Slight smoke or odor during initial operation	<ol style="list-style-type: none"> Residues from manufacturing Not enough air Gas regulator defective 	<ol style="list-style-type: none"> Problem will stop after a few hours of operation Check burner for dirt and debris. If found, clean burner (see Cleaning and Maintenance, page 16) Replace gas regulator
Log set produces a whistling noise when burner is lit	<ol style="list-style-type: none"> Turning control to “HI” position when burner is cold Air in gas line Air passageways on heater blocked Dirty or partially clogged burner orifice 	<ol style="list-style-type: none"> Turn control knob to “LO” position and let warm up for a minute Operate burners until air is removed from line. Have gas line checked by local natural or propane/LP gas company Observe minimum installation clearances (see page 10) Clean burner (see Cleaning and Maintenance, page 16) or replace burner orifice
White powder residue forming within burner box or on adjacent walls or furniture	<ol style="list-style-type: none"> When heated, vapors from furniture polish, wax, carpet cleaners, etc. turn into white powder residue 	<ol style="list-style-type: none"> Turn log set off when using furniture polish, wax, cleaners, or similar products
Log set produces a clicking/ticking noise just after burner is lit or shut off	<ol style="list-style-type: none"> Metal expanding while heating or contracting while cooling 	<ol style="list-style-type: none"> This is normal with most log sets. If noise is excessive, contact a qualified service person.
No yellow flame (mostly blue)	<ol style="list-style-type: none"> Not enough combustion/ventilation air 	<ol style="list-style-type: none"> Refer to Air For Combustion and Ventilation requirements, page 4
Tall, yellow flames (soot may be visible)	<ol style="list-style-type: none"> Unit is not the correct gas type for the gas supply 	<ol style="list-style-type: none"> Discontinue use! Have a qualified service person verify Gas Type.
Moisture/condensation noticed on windows	<ol style="list-style-type: none"> Not enough combustion/ventilation air 	<ol style="list-style-type: none"> Refer to Air For Combustion and Ventilation requirements, page 4
Remote control does not function	<ol style="list-style-type: none"> Remote is not communicating with unit Battery is low on power or not installed/not correctly installed 	<ol style="list-style-type: none"> Follow directions under <i>Using the Learn Function</i> Page 10 Replace batteries and verify the polarity (+ and - ends correspond with + and - terminal in remote)

TROUBLESHOOTING

continued

- ⚠ WARNING: If you smell gas**
- Shut off gas supply.
 - Do not try to light any appliance.
 - Do not touch any electrical switch; do not use any phone in your building.
 - Immediately call your gas supplier from a neighbor's phone. Follow the gas supplier's instructions.
 - If you cannot reach your gas supplier, call the department.

IMPORTANT: Operating appliance where impurities in air exist may create odors. Cleaning supplies, paint, paint remover, cigarette smoke, cements and glues, new carpet or textiles, etc., create fumes. These fumes may mix with combustion air and create odors. These odors will disappear over time.

OBSERVED PROBLEM	POSSIBLE CAUSE	REMEDY
Heater produces unwanted odors	<ol style="list-style-type: none">1. Heater burning vapors from paint, hair spray, glues, cleaners, chemicals, new carpet, etc. (see IMPORTANT statement above)2. Low fuel supply (propane/LP gas only)3. Gas leak. See Warning statement at top of page	<ol style="list-style-type: none">1. Open window and ventilate room. Stop using odor-causing products while heater is running2. Refill supply tank (propane/LP gas only)3. Locate and correct all leaks (see <i>Checking Gas Connections</i>, page 11)
Heater shuts off in use (ODS operates)	<ol style="list-style-type: none">1. Not enough fresh air is available2. Low line pressure3. ODS/pilot is partially clogged	<ol style="list-style-type: none">1. Open window and/or door for ventilation2. Contact local natural or propane/LP gas company3. Clean ODS/pilot (see <i>Cleaning and Maintenance</i>, page 16)
Gas odor even when control knob is in OFF position	<ol style="list-style-type: none">1. Gas leak. See Warning statement at top of page2. Control valve or gas control defective	<ol style="list-style-type: none">1. Locate and correct all leaks (see <i>Checking Gas Connections</i>, page 9)2. Replace control valve or gas control
Gas odor during combustion	<ol style="list-style-type: none">1. Foreign matter between control valve and burner2. Gas leak. See Warning statement at top of page	<ol style="list-style-type: none">1. Contact a qualified service technician to remove foreign matter2. Locate and correct all leaks (see <i>Checking Gas Connections</i>, page 9)

WIRING DIAGRAM

Note: For proper operation of appliance, the wires from the switch, electronic module, and valve must be attached exactly as shown:

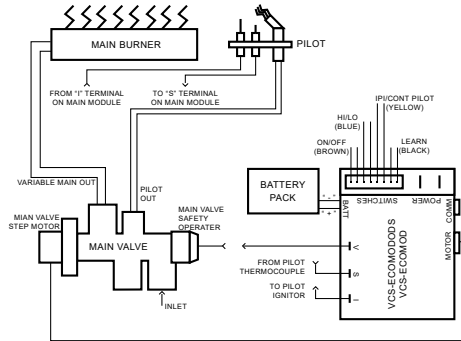

Figure 24 - Wiring Diagram

SPECIFICATIONS

Model	(S,B)VFA18NG	(S,B)VFA18LP	(S,B)VFA24NG	(S,B)VFA24LP
Gas Type	Natural Gas	Propane/LP	Natural Gas	Propane/LP
Input Max.	34,000 BTU/Hr	34,000 BTU/Hr	39,000 BTU/Hr	39,000 BTU/Hr
Input Min.	22,000 BTU/Hr	22,000 BTU/Hr	22,000 BTU/Hr	22,500 BTU/Hr
Manifold Pressure	3.5" W.C.	10.0" W.C.	3.5" W.C.	10.0" W.C.
Inlet Pressure Max.	10.5" W.C.	14.0" W.C.	10.5" W.C.	14.0" W.C.
Inlet Pressure Min.*	7.0" W.C.	11.0" W.C.	7.0" W.C.	11.0" W.C.
Minimum Firebox Size	18" H X 22" W X 12" D		18" H X 28" W X 15" D	

ATTENTION!

The following listed items are possible warning codes from your burner system:

One beep per second

Ignition Safety (Protection for Ignition system)
Recycle Safety: (Protection for Unstable Pilot)

Description of Fault - Pilot is not successfully ignited within the trial period.

Action - The control will operate the gas valve to the "OFF" position.

How to Clear - Cycle "ON/OFF" switch to "OFF" position

Two beeps per second

Automatic Recycle

Description of Fault - Pilot is proven and lost 3-times within 2-minutes without multiple "ON/OFF" commands.

- Automatic Recycle (VCS-ECOMODODS) - Pilot is established, then lost.

- Manual Recycle – Ignition sequence is initiated 6-times within 2-minutes.

Action - The control will operate the gas valve to the OFF position

How to Clear - After 5-minutes has elapsed (5-minute internal timer expires), the module must see the mode/switch in the "OFF" position after that time. Once the module see's the mode/switch in the "OFF" position after the 5-minutes has elapsed, it will stop beeping.

- Once the beeping has stopped, it will accept normal operation including another "ON" command from the user.

4 beeps per second (constant beeping)

Sensor Safety (Protection for Flame sensor)

Description of Fault - Pilot flame sensor temperature is too high when ignition sequence

is initiated.(unit has not cooled down before re-starting).

Action - The control will operate the gas valve to the "OFF" position.

How to Clear - Cycle the ON/OFF switch to the "OFF" position.

4 beeps every two seconds

Thermal Safety (Overheat Protection)

Description of Fault - Internal temperature has exceeded 170 deg. F.

Action - The module will operate the gas valve to the "OFF" position.

How to Clear – The module's internal temperature must cool to below 160 deg. F and cycle the "ON/OFF" switch to the "OFF" position.

ILLUSTRATED PARTS BREAKDOWN

(S,B)VFA FULLY AUTO MODELS

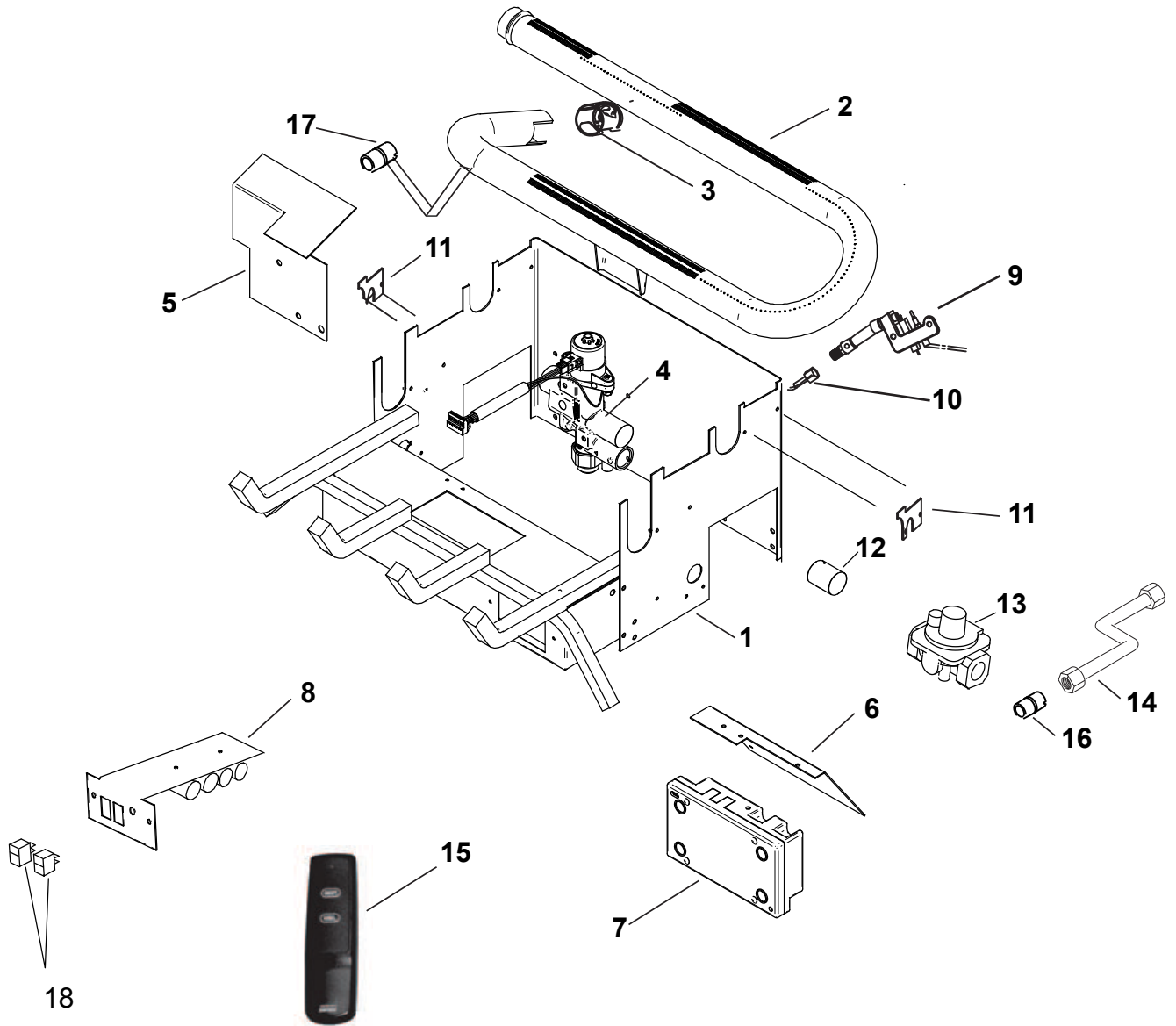

(S,B)VFA FULLY AUTO MODELS

PARTS LIST KEY

Item	Part Description	Part Number				Qty.
		SCVFA18NG	SCVFA18LP	SCVFA24NG	SCVFA24LP	
1	Main Support Assembly	RMH-120-LLC18	RMH-120-LLC18	RMH-120-LLC24	RMH-120-LLC24	1
2	Dual Burner	RHM-120-01120	RHM-120-01120	RHM-120-01430	RHM-120-01430	1
3	Air Shutter, Burner	RMH-120-00260	RMH-120-00254	RMH-120-00260	RMH-120-00254	1
4	Gas Control Valve	RMH-120-00152NGMR	RMH-120-00152LPMR	RMH-120-00152NGMR	RMH-120-00152LPMR	1
5	Heat Shield	RMH-120-COPHS	RMH-120-COPHS	RMH-120-COPHS	RMH-120-COPHS	1
6	Module Bracket	RMH-120-COPMB	RMH-120-COPMB	RMH-120-COPMB	RMH-120-COPMB	1
7	Module Board	RMH-120-ECOMOD	RMH-120-ECOMOD	RMH-120-ECOMOD	RMH-120-ECOMOD	1
8	Switch Plate (Batt Box)	RMH-120-SWP/BB	RMH-120-SWP/BB	RMH-120-SWP/BB	RMH-120-SWP/BB	1
9	Pilot, ODS	RMH-120-57827	RMH-120-7818	RMH-120-57827	RMH-120-7818	1
10	Tube, ODS Pilot	RMH-120-90434A	RMH-120-90434A	RMH-120-90434A	RMH-120-90434A	1
11	Burner Clip	SBNCJ00071A	SBNCJ00071A	SBNCJ00071A	SBNCJ00071A	2
12	Pipe Nipple	RMH-120-90860	RMH-120-90860	RMH-120-00048	RMH-120-00048	1
13	Regulator	RMH-120-COPNG	RMH-120-00222	RMH-120-COPNG	RMH-120-00222	1
14	Connection Tube	KHH-ACT16	KHH-ACT16	KHH-ACT16	KHH-ACT16	1
15	Remote Handset	RMH-120-1001TH	RMH-120-1001TH	RMH-120-1001TH	RMH-120-1001TH	1
16	Fitting 1/2" NPT X 3/8" Flr	SH-111	SH-111	SH-111	SH-111	1
17	Orifice Tube	RMH-120-FABST	RMH-120-FABST	RMH-120-FABST	RMH-120-FABST	1
18	Switch, ON/OFF and HI/LO	RMH-120-68513	RMH-120-68513	RMH-120-68513	RMH-120-68513	
Parts available but not shown						
	Wire, Flame Sensor	8600338	8600338	8600338	8600338	1
	Wire, Igniter	RMH-120-840000020	RMH-120-840000020	RMH-120-840000020	RMH-120-840000020	1
	Wire harness - Valve	RMH-120-584912	RMH-120-584912	RMH-120-584912	RMH-120-584912	1
	Nut, ODS Mounting	RMH-120-00051	RMH-120-00051	RMH-120-00051	RMH-120-00051	2
	Screw, Hex 8 X 3/8	RMH-122-00625	49738375	49738375	49738375	6
	Decorative Rock	WIP-130-00050	WIP-130-00050	WIP-130-00050	WIP-130-00050	1

SERVICE INFORMATION

REPLACEMENT PARTS

Note: Use only original replacement parts. This will protect your warranty coverage for parts replaced under warranty.

Parts Under Warranty

Contact authorized dealers of this product. If they can't supply original replacement part(s), call Sure Heat Manufacturing Technical Service Department at (800) 229-5647.

When calling Customer Service, have ready:

- your name
- your address
- model and serial numbers of your heater
- how appliance was malfunctioning
- type of gas used (propane/LP or natural gas)
- purchase date

Usually, we will ask you to return the part to the factory.

Parts Not Under Warranty

Contact authorized dealers of this product. If they can't supply original replacement part(s), call SHM International at (800) 229-5647 for referral information. When calling Sure Heat Manufacturing, have ready:

- model number of your appliance
- the replacement part number

SERVICE HINTS

When gas pressure is too low:

- pilot will not stay lit
- heater will not produce specified heat
- propane/LP gas supply may be low

You may feel your gas pressure is too low. If so, contact your local natural or propane/LP gas supplier.

Note: Use only original replacement parts. This will protect your warranty coverage for parts replaced under warranty.

TECHNICAL SERVICE

You may have further questions about installation, operation or troubleshooting. If so, contact Sure Heat Manufacturing Technical Service Department at (800) 229-5647.

When calling please have your model and serial numbers of your heater ready. You can also visit SHM International's Technical Service web site at www.sureheat.com.

WARRANTY INFORMATION

KEEP THIS WARRANTY

Model _____
Serial No. _____
Date Purchased _____

Always specify model and serial numbers when communicating with the factory.

LIMITED WARRANTY

SHM International Corp. warrants the components of this appliance to be free from defects in material and workmanship for one (1) year from the date of purchase. SHM International Corp. at its option, will repair or replace this product or any component of the product found to be defective during the warranty period. Replacement will be made with a new manufactured product or component. If the product is no longer available, replacement may be made with a similar product of equal value. This warranty does not include transportation or shipping costs of any kind. This your exclusive warranty.

This warranty is valid for the original retail purchaser from the date of initial retail purchase and is not transferable. Keep the original sales receipt. Proof of purchase is required to obtain warranty parts.

This warranty does not cover normal wear of parts such as scratches and dents of the components or damage resulting from any of the following:

- negligent use or misuse of the product, including exposing the product to chemicals or cleaning products not approved by SHM International Corp.
- corrosion, rust or discoloring of any kind
- use or installation contrary to specified instructions and applicable building codes, including heating the product to temperatures above its rated specifications which can cause considerable warping
- disassembly, including removal of the product from a built-in installation
- damage resulting from accident, alteration, misuse, abuse, hostile environments, or improper installation
- repair or alteration
- acts of God, such as fire, flood, hurricanes, and tornadoes
- gas cylinders, propane tanks or other fuel delivery systems, including connections to a household fuel supply
- usage other than single-family household use such as commercial or industrial use
- minor warping or discoloration of parts, which is normal and not a defect under this warranty

DO NOT RETURN THIS PRODUCT TO THE PLACE OF PURCHASE

If the appliance does not operate properly, first thoroughly carry out the instructions provided with the unit to ensure that the appliance is installed correctly and check the troubleshooting section in the use and care manual.

We recommend you return the warranty registration card so that you can be contacted when any questions of safety arise that could affect you. The return of the warranty registration card is not a condition for warranty coverage.

Because of continuing product improvement, these specifications are subject to change without notice.

If you have other questions or need replacement parts, contact our
Customer Service Hotline at (800) 229-5647 or
visit our website at www.sureheat.com.

SHM International Corp. 3140 Moon Station Road, Kennesaw, GA 30144