

Lavatory Faucet S-20-BH Series Installation and Service Instructions

For California Residents

WARNING: This product contains chemicals known to the State of California to cause cancer, birth defects, or other reproductive harm.

Caution: Be sure to turn off hot and cold water supplies before installing or servicing faucet.

1. Place gasket on base of faucet then loosely install the anchor bar (KN-23), spacer (KN-26) and nut (L-36) on the mounting bolts. Push faucet supplies and anchor bolt/spacer/nut assemblies with gasket through holes in sink. Secure faucet to sink by tightening nuts from underside. (If sink or counter surface is uneven, use putty or sealant to make proper seal under base.)
2. Connect supply hoses to supply stops (left hose to hot, right to cold). Hot hose is marked with tag. Note: If the LCT handle is being used the supplies will be reversed. The right side hose will be marked hot and should cross over and be connected to the hot supply. Connect the left side hose to the cold supply.
3. **Pop-up drain installation:**
 - a) Remove pop-up plug, tail piece and flange from the drain body. Make sure that locknut is threaded all the way down onto the body with flat friction washer in middle and beveled washer on top.
 - b) Apply plumbers putty or sealant to bottom of flange.
 - c) Install drain body through drain opening in lavatory and screw flange onto the drain body making sure that the threads are completely engaged for proper sealing and strength of the connection. Apply joint compound to all threaded parts to insure proper seal. Apply putty or teflon tape to tail piece before attaching to drain body.
 - d) Tighten locknut to compress the beveled flange evenly across the bottom of the drain opening taking care not to over tighten the locknut, causing damage to the lavatory.
 - e) Remove one of two ball washers from inside the threaded cavity. Insert pop-up plug and pivot rod into body. Add one ball washer (the second ball washer should remain inside the body) to the outside of the ball. Tighten the retaining nut until the ball is seated on the internal and external ball washers. Note: The pop-up plug can be installed either in the removable or non-removable position, depending on the location of the hole located in the guide at the bottom of the plug.
 - f) Slide the pivot rod through one side of the spring clip, then the appropriate adjustment hole and then other side of the spring clip.
 - g) Insert lift rod through faucet housing and the top of the lift strap and secure it in place by tightening the screw. Note: To insure proper operation of lift rod and pop-up,

some adjustment of the linkage may be required. There are two possible adjustment points:

- 1) lift strap to lift rod and
- 2) lift strap to pivot rod.

4. It is very important to thoroughly flush the supply lines to prevent foreign matter, i.e. copper chips, sand, stones, etc. from damaging the sealing surfaces of cartridge. Remove aerator and turn valve handle on to full cold position, open cold supply. Without closing, turn handle to full hot and open hot supply. Let water run in hot only and cold only positions long enough to flush supply lines thoroughly. Shut off faucet and replace aerator. Check for leaks.
5. The handle limit stop can be set to limit handle turn to the hot position. The limit mechanism is factory set to allow full handle travel. To adjust the limit stop, turn handle to the full hot position and lift handle to open faucet approximately half way to obtain a smooth flow for correct initial temperature measurement.
6. If when faucet is on and in full hot position and water is too hot, remove plug button (KN-157), loosen set screw (L-22) and remove handle (KN-3RB, KN-3BRB or LN-135) or plug button (T-33), screw (LN-171), and handle (LN-122). Lift limit stop ring using a small flat head screw driver and rotate counter clockwise to lower temperature. If water is not hot enough, rotate clockwise (See Figure 1 on reverse side). After correct temperature is achieved, reattach handle, reversing procedure above.

Cartridge Replacement (KN-4):

1. Remove plug button (KN-157), loosen set screw (L-22) and remove handle (KN-3RB, KN-3BRB or LN-135) or plug button (T-33), screw (LN-171), and handle (LN-122).
2. Engage tabs in cartridge wrench (LN-34) with slots in compression ring (KN-2) and use screwdriver in wrench holes or pliers on wrench and turn counter clockwise until compression ring engages with cap (LN-8). Continue turning counter clockwise so that cap/ring assembly is removed from the body (LN-371BH). Remove cartridge and three ring seal (KN-4). Install new cartridge while taking care to maintain position of the three ring seal at the base of the cartridge. Match posts in base of cartridge with alignment holes in valve body during assembly. Reassemble faucet in reverse fashion. Thread cap onto body firmly by hand. Do not use a wrench which may damage the finish. Tighten compression ring (KN-2) finger tight using the wrench (LN-34) then 1/4 to 1/2 turn further. Set hot water limit stop in accordance with installation step 5 above.

Dimensions Symmetrix Lavatory Faucet, S-20-2-BH (with braided supply hose)

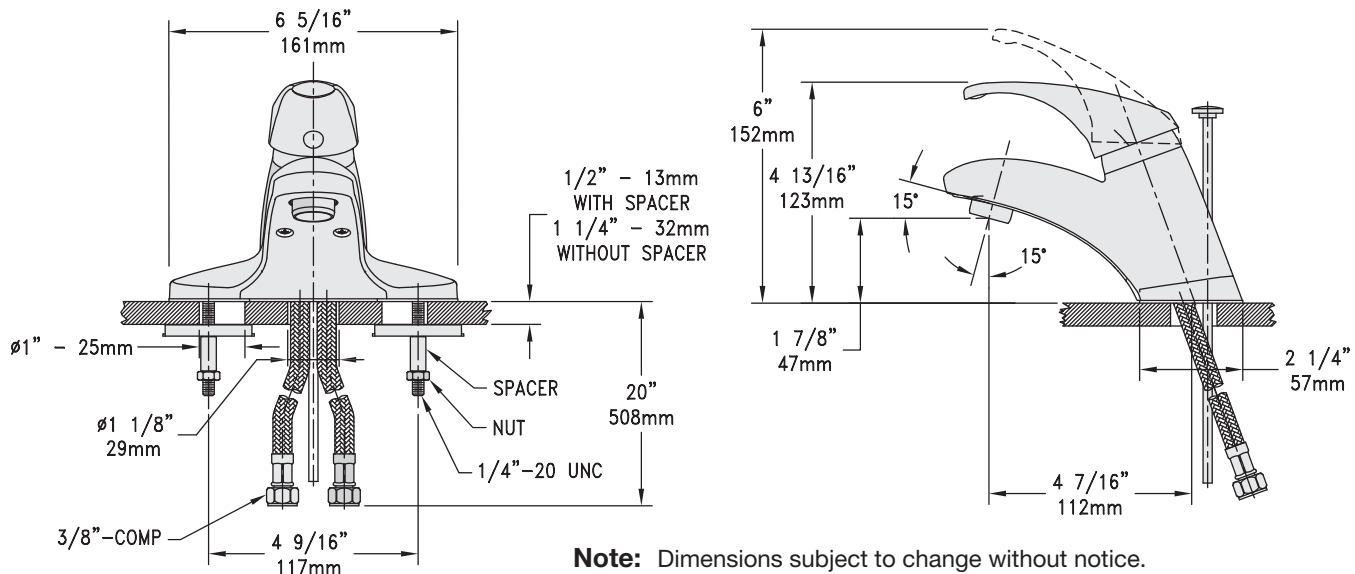

Parts Assembly Symmetrix Lavatory Faucet, S-20-BH Series

- | | |
|----------|--|
| KN-2 | Compression ring |
| KN-3RB* | Solid handle |
| KN-3BRB* | Loop handle |
| KN-4 | Cartridge |
| KN-23 | Anchor bar (2) |
| KN-26 | Mounting spacer (2) |
| KN-157 | Plug button |
| LN-8* | Valve cap |
| LN-11* | Screw (2) |
| LN-15* | Aerator |
| LN-34 | Cartridge wrench (not shown) |
| LN-100 | Aerator (vandal resistant 0.5 gpm) |
| LN-101 | Aerator (vandal resistant) |
| LN-122 | Acrylic Handle |
| LN-135 | 6" lever handle with red/blue indicators |
| LN-171 | Screw |
| LN-363* | Undercover plate |
| LN-370 | Mounting gasket |
| LN-371BH | Cartridge housing assembly |
| L-22 | Set screw |
| L-36 | Mounting nut (2) |
| L-42 | Nut (2) |
| RL-154* | Pop-up drain assembly (complete) |
| P-26 | Grid drain assembly (complete) |
| T-33 | Plug button |

For Decorative Finish Faucets add suffix to parts marked with an asterisk as follows:
 Suffix -STN: Radiance® Satin finish
 Suffix -BC: Brushed chrome

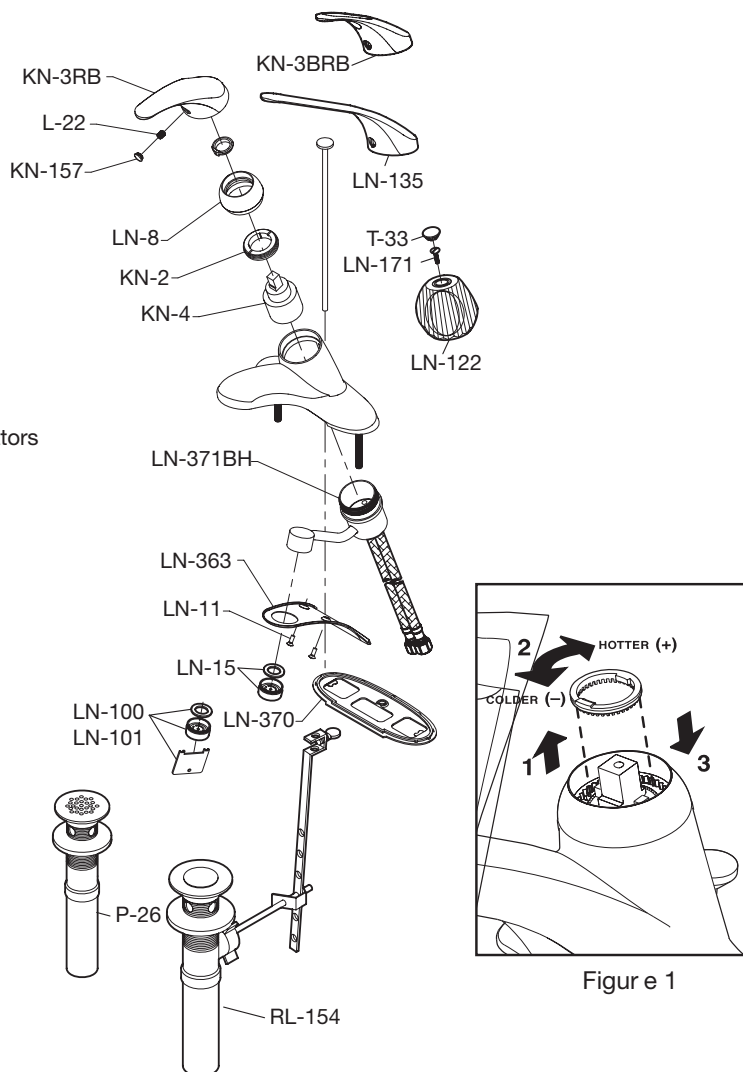

Figure 1