

**TAYAMA®**  
**Convection Oven**  
**TO-2000**



**SAVE INSTRUCTIONS FOR FUTURE REFERENCE**

## **Important Safety Instructions**

These basic safety precautions should always be followed:

1. Read all instructions before using the convection oven.
2. DO NOT touch hot surfaces. The temperature of the outer surface can get very hot while the Convection Oven is in operation. Always use gloves when handling hot materials and allow metal parts to cool before cleaning. Allow the unit to cool thoroughly before putting in or taking out parts. Always use the handles when moving the unit.
3. DO NOT use the Convection Oven for other than its intended use.
4. Before turning on, ensure the electrical voltage and frequency of the circuit corresponds to those indicated on the rating label of the appliance.
5. To protect against the risk of electric shock, do not immerse this Convection Oven, cord set or plug in water or any other liquids.
6. The Convection Oven is not intended to be operated by means of an external timer or any type of separate remote control system.
7. The use of attachments which are not recommended or sold by the manufacturer may cause fire, electric shock or injury.
8. This appliance is designed for indoor use only. DO NOT use outdoors.
9. DO NOT use an extension cord unless completely necessary with this product. If an extension cord is used please ensure that it has a rating equal or exceeding the rating of this appliance.
10. DO NOT pull or carry by cord, use cord as a handle, close a door on the cord, or pull cord around sharp edges or corners. Keep cord away from heated surfaces.
11. DO NOT bend or damage the power cord.
12. Always unplug the Convection Oven when not in use. To disconnect from the power supply, grip the plug and pull from the power socket. Never pull by the cord. The power plug must be removed from the power socket before cleaning, servicing, maintenance or moving the convection oven.
13. Never force the plug into an outlet.
14. DO NOT place the appliance near a hot gas or electric burner.

15. DO NOT cover the appliance whilst in use. If it is covered there is a risk of fire.
16. Improper installation may result in the risk of fire, electric shock and/or injury to persons.
17. If the supply cord or plug is damaged, DO NOT use the appliance. Please contact customer service for a replacement power cord.
18. The manufacturer or retailer is not responsible for any eventual damages caused by improper or faulty use.
19. The unit has no user-serviceable parts contained within. Do not attempt to repair, disassemble or modify the appliance.
20. Always operate on a dry level surface. Operating on sinks or uneven surfaces must be avoided.
21. DO NOT clean with metal scouring pads.
22. Extreme caution must be used when moving an appliance containing hot oil or other hot liquids.
23. DO NOT move or lift the Convection Oven while the power cord is still connected to the wall outlet. All metal items inside the Convection Oven, such as the oven racks, can get very hot during cooking. Please be careful when removing these items from the Convection Oven, always use the tongs supplied.
24. This appliance is intended to be for “ Household Use Only” and similar application.

## A Tradition of Quality Convection Oven

### **Introduction**

The multi-functional Convection Oven has brought an end to the traditional cooking way. While cooking, the Convection Oven produces a circle of hot moving air, which cooks the food all over evenly. The cooked food becomes a very delicious dish with its natural flavor and full nutrition.

The model of the Convection Oven is reasonably designed with attractive appearance. In it, there is a 65 – 250°C (149-482° F) scope temperature controller (thermostat) and 0-60 minute scope timer. You may select the cooking temperature and cooking time for your food. The Convection Oven

not only saves you from the heavy kitchen work, but also makes your cooking enjoyable.

### Technical specification

Voltage	120 V / 60Hz
Rated power	1200W
Thermostat	65 – 250 °C/149°F -482°F
Timer	0-60 minutes
Container capacity	Ø 300 x 150 mm
Gross weight	8.5 kg
Net weight	7 kg

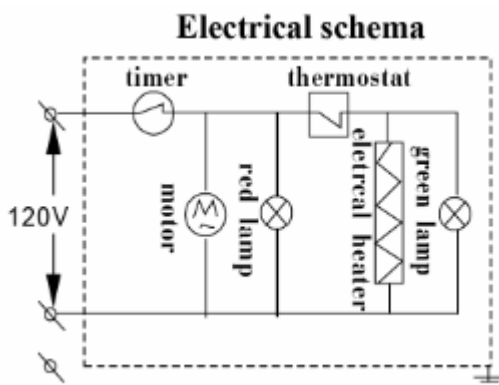

### Operation

- When cooking with the accessory cooking racks included be sure to allow space between the lid and food. Extension Ring accessory may be purchased separately.
- Insert the oven plug according to the power specification. Do not share the same plug-set with other electrical appliances.
- **TIMER:** Turn the timer clockwise to your desired time, the red indicator light will turn on.
- **TEMPERATURE:** Set the temperature controller clockwise to your desired temperature, the green light will turn on. The Convection Oven will start cooking.

- When the green light turns off the oven has achieved the set temperature. When the oven's temperature becomes lower than what you need, the oven will automatically turn the heater on and the green lamp will also turn on to indicate heating process.

## Important

1. Always operate under supervision. Do not allow children to operate.
2. Use caution when removing and handling the oven lid. Place it on a dish, bowl or heat-resistant base/surface.
3. Do not wash or immerse the oven lid in water. Clean the lid with a soft cloth and mild soap in case it gets stained.
4. The oven body can be washed only after it has completely cooled off.

## Convection Oven Features:

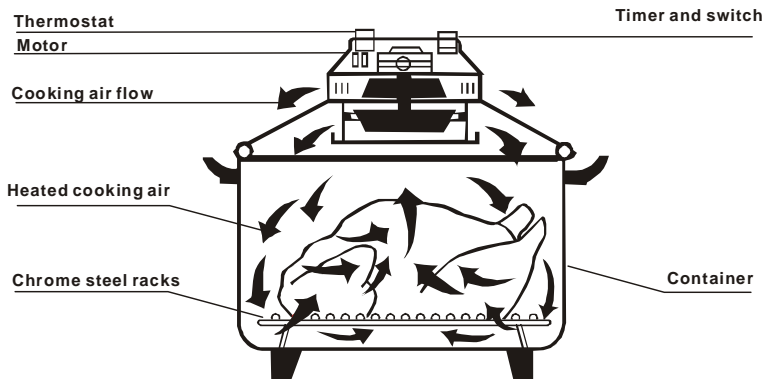

## Multi-function

With hot air circulation and 65-250°C (149-482° F) temperature range, the convection oven has a lot of functions:

- Cooks food in a variety of ways, including baking, roasting, grilling, toasting, broiling, and barbeque.
- Defrost/Thaw frozen foods quickly

## 2. Lowering Cholesterol

Cooking with the Convection Oven will reduce and minimize the use of cooking with fats and oils. Providing healthier meals and lowered cholesterol.

## 3. Saving time and energy

Due to the high efficiency of the halogen convection oven, the cooking time and the consumed energy are reduced to minimum. The convection oven saves up to 20% electricity as compared to ordinary ovens and cooks 3 to 5 times faster.

## 4. Preserving the food's nutrition and the natural flavor.

High temperature and prolonged cooking time always strips the foods nutrition and changes its natural flavor. The temperature and time control on the convection oven will cook your food to perfection without over cooking and drying out all the nutrients and flavors.

## Quick Reference Card

**On this card you will find:**

- |                      |                      |                        |
|----------------------|----------------------|------------------------|
| <b>-How to roast</b> | <b>-How to bake</b>  | <b>-How to defrost</b> |
| <b>-How to steam</b> | <b>-How to fry</b>   |                        |
| <b>-How to toast</b> | <b>-How to broil</b> |                        |



### How to Broil

- Place the food directly on the wire rack (low or high rack)
- For very thick cuts of meat , turn the food at the halfway point
- Like roasting, broiling time may vary depending on cut, size, amount of fat, etc.

## ✧ How to Steam

- You can steam vegetables at the same time you cook your main dish by placing the vegetables in an aluminum foil pouch and adding a few drops of water and seal the foil pouch.
- You can also add a cup of water in the bowl with savory herbs and spices to steam fish or vegetables.

## ✧ How to fry

- You can get the effect of deep-fry French fries without all the oil by dipping potato strips in polyunsaturated cooking oil, allow excess oil to drain away and cook according to cooking guide.
- To make delicious fried chicken, dip chicken pieces in batter and then in cooking oil, drain excess oil and cook according to chart provided.

## ✧ How to Toast

- You can get perfectly toasted bread and snacks with the convection oven without preheating. Simply put the food directly on wire rack and watch it toast. It will be crisp on the outside and stay soft on the inside.
- You can also improve stale snack food like crackers, chips and even cookies by placing them in the convection oven for a few minutes at maximum temperature to bring back their crunchiness.

## ✧ How to Defrost

- You can use the convection oven to defrost frozen food more evenly than a microwave oven. Simply set the temperature at 212°F and check the food every 5-10 minutes.

## ✦ **General guidelines and warning**

-Remember to distribute food evenly in the convection oven to ensure an even flow of air is able to circulate around the food.

-The first time you try a recipe, check the cooking process through the tempered glass bowl as the cooking time of the convection oven is very quick.

-Since it is practical to place food directly on the wire rack, you may want to spray it with a non-stick spray to avoid food sticking.

-The convection oven is self-cleaning. Simply put 2” of water in the bottom and set temperature at 212°F for 10-12 minutes.

-For a very dirty oven, add some detergent to the water and wipe the stains if needed.

## **Suggested Recipes**

### **Lobster**

#### *Ingredients:*

Lobster 1 kg, ginger juice, salt, sugar, liquor, pepper

Preserve the lobster in salt for about 10-15 minutes, then put them in the convection oven and cook 12-15 min with temperature of 284-320°F.

### **Crispy Chicken**

#### *Ingredients:*

Chicken, a little starch, some wine, malt sugar, honey, vinegar, warm water

1. Wash and clean the chicken with boiling water and then with cold water immediately after.
2. Mix the starch, melted sugar, honey and vinegar with some water. Apply the mixture to the chicken with a brush several times. When the chicken dries, put it into the convection oven.
3. Bake the chicken 20 min with a temperature of 302 – 392°F. Then apply the mixture again and bake 10 min in low temperature.



## Cooking Time & Temperature Reference:

Food	time	temperature
Chicken	30-40 min	180-200°C 356-392°F
Fish	10-15 min	130-150°C 266-302°F
Cake	10-12 min	140-160°C 284-320°F
Lobster	12-15 min	140-160°C 284-320°F
Shrimp	10-12 min	150-180°C 302-356°F
Sausage	10-13 min	120-150°C 248-302°F
Peanut	10-15 min	140-160°C 284-320°F
Roasted bread	8-10 min	120-140°C 248-284°F
Potato	12-15 min	180-200°C 356-392°F
Chicken wings	15-20 min	150-180°C 302-356°F
Crab	10-13 min	140-160°C 284-320°F
Hot dogs	5-8 min	190-210°C 374-410°F
BBQ Spareribs	18-20min	220-240°C 428-464°F

## Recommended Recipes for Convection Ovens

### **FRENCH POTATO CHIPS**

⌚ 15 to 20 minutes airfryer

300-400 g frozen potato chips

1 tablespoon oil

$\frac{1}{3}$  tablespoon salt

1. Spray the oil onto the potato chips.
2. Put the potato chips in a small fryer basket.
3. Place the basket into the convection oven. Set the timer to 15-20 minutes and Temperature at 482°F and fry the potatoes until they are crispy brown.
4. Arrange chips on a plate and sprinkle lightly with salt.

## ROAST CHICKEN



- 1 Chicken
- 1 Small onion
- 2 Tablespoon of butter
- 1/2 Cup of mushrooms
- 1 1/2 Cup of soft breadcrumbs
- 1 Tablespoon of chopped parsley
- 1 Pinch of nutmeg
- 1 Teaspoon grated lemon rind
- 1/4 Teaspoon dried marjoram
- Garlic, salt, pepper
- 1 Egg

Clean inside of the chicken and remove excess fat. Peel and chop onion. Add to pan and lightly fry in butter until soft. Add mushrooms and fry another minute. Mix in crumbs, salt, pepper, parsley, lemon rind, marjoram, nutmeg and beaten egg. Put stuffing into chicken and close the opening and sprinkle salt and pepper over chicken and rub into skin. Roast at **482°F** for **15** minutes until chicken is tender and golden brown all over.

## GRAVY

Take scraps and juice plus a little fat from your bowl. Add 1 tbsp of flour and stir over heat until brown. Slowly add 1 1/2 cups of stock made from chicken stock cube and mushroom stalks. Cook gravy, stirring continuously, until boiling. Add salt and pepper to taste.

## STUFFED BREAST OF VEAL



- 1. 5kg breast, boned with pocket cut
- 2 tbsp butter
- Garlic, salt and pepper
- STUFFING:**
- 1 Tablespoon butter
- 1 Tablespoon of lemon juice
- STUFFING continued:**
- 1 Tablespoon grated lemon rind
- 1 Cup of diced mushroom
- 2 Cups of fresh white breadcrumbs
- 1 Egg, lightly beaten
- 1/2 cup of finely chopped onions
- Cream

Preheat frying pan. Melt 1 tablespoon of butter in the pan and fry onion until soft. Add lemon rind and juice, garlic and mushrooms. Fry together for 3-4 minutes. Set aside in large bowl. Add bread-crumbs, garlic, salt and pepper to fried vegetables. Bind together with egg and enough cream to form a firm consistency.

Place stuffing into veal pocket and spread evenly then reseal the cavity. Brush veal with soft butter and place on a low rack in the convection oven.

## CHINESE ROAST CHICKEN



- |  |  |
|--|--|
| <b>1.5kg roasting chicken, chicken wings or drumsticks</b> | <b>1 teaspoon five-spice powder</b>    |
| <b>1/3 cup soy sauce</b>                                   | <b>1 teaspoon crushed garlic</b>       |
| <b>1 tablespoon honey</b>                                  | <b>1 teaspoon finely grated ginger</b> |
|  | <b>1 tablespoon sesame oil</b>         |

Marinate the chicken pieces or chicken in the other ingredients for at least **2** hours, turning pieces now and then.

Arrange chicken on the rack in the convection oven and cook at **482°F** for **8** minutes for wings, **10** minutes for legs, thighs, **12** minutes for 1/4 or 1/2 chicken. Turn and cook until ready – be sure to check chicken has cooked evenly all the way through before serving.

Serves **6**.

## HONEY CHICKEN WINGS



- 0.7kg chicken wings**
- 2 Tablespoons of honey**
- 3 Tablespoons of tomato puree**

- MARINADE:**
- 2 tablespoon of lemon juice**
  - 3 tablespoons of soy sauce**
  - 1 tablespoons of chopped ginger**

Trim excess fat from chicken wings and remove tips. Pat wings dry and place in a bowl. Combine lemon juice, soy sauce and ginger. Pour over chicken wings, turn and let stand for 3 to 4 hours while turning occasionally. Mix honey, tomato puree and a tbs of marinade. Remove chicken wings and place on cooking rack in the convection oven. Roast for **8** minutes at **428°F**. Remove wings and roll in honey/tomato mixture.

## INDIVIDUAL BEEF WELLINGTON



- |   |                                 |
|---|---------------------------------|
| <b>0.7kg 4"thick fillet steaks</b>                                  | <b>1 tablespoon brandy</b>      |
| <b>1 tablespoon butter</b>  | <b>2 tablespoons liverwurst</b> |
| <b>1 packed frozen puff pastry, thawed. Garlic, salt and pepper</b> |                                 |
| <b>1 egg yolk, beaten with a little water</b>                       |                                 |

Trim excess fat from steaks. Sprinkle with garlic, salt, and ground pepper. Place on low rack in the convection oven.

Mix liverwurst with brandy and spread all over steaks. Roll out pastry and cut into 4 squares large enough to enclose each steak. Place steak in center of each pastry square and fold over to completely enclose. Seal seams with a little water and brush top with beaten egg yolk. Place back on low rack in the convection oven and cook at **419°F** for **10** minutes or until golden brown. Serves **4**.

## ROAST VEGETABLES



**Vegetables of your choice**  
**Ground black pepper**

**Garlic and salt**  
**2-3 tablespoons of cooking oil**

Peel and clean vegetables. Cut into similar size pieces. Pat dry and place in a large pot with 2 or 3 tbsp of vegetable oil add garlic, salt and pepper . Place lid on pot, shake and rotate vigorously. Place vegetables on high rack in the convection oven leaving space for air to circulate particularly around the perimeter. Set Halogen Convection Oven to **392°F** and bake for approximately **8 to 12** minutes. The cooking time will vary depending on the size of individual pieces and the total weight in the oven. Vegetables can be roasting while meat is cooking by placing around the meat and/or by utilizing the high rack and perforated baking dish.

## JACKETED POTATOES IN FOIL



**Medium size washed potatoes**  
**(1 per person)**

**Soft Butter**  
**Garlic Salt**  
**Ground Black Pepper**

Make sure potatoes are clean. Remove any eyes, bruises, faults etc. Dry with paper towel. Rub a little softened butter onto potatoes. Place on foil paper. Sprinkle with a little garlic, salt and freshly ground black pepper. Wrap up in foil paper.

Place potatoes on high rack in the convection oven and cook 20 minutes at **392°F** check with a fork to see that they are cooked through. Serve with sour cream, chives, grated chese and cooked bacon pieces.

For a variation, mix a little Soy Sauce into the butter before rubbing into the potatoes omitting the garlic salt.

## Roasted Paprika Potatoes with Greek Yoghurt

Side dish - 4 portions

🕒 20 minutes convection oven

500 g waxy potatoes

2 tablespoons olive oil

1 tablespoon spicy paprika

Freshly ground black pepper

150 ml Greek yoghurt

1. Set the convection oven to 482°F. Peel the potatoes and cut them into 2 cm cubes. Soak the cubes in water for at least 30 minutes. Drain them thoroughly and then pat them dry with paper towel.
2. In a medium-sized bowl, mix 1 tablespoon olive oil with paprika and add pepper to taste. Coat the potato cubes with the spicy oil.
3. Transfer the potato cubes to a fryer basket and place the basket into the convection oven. Set the timer to 20-22 minutes and fry the potato cubes until they are golden brown and done.
4. Mix the Greek yoghurt in a small bowl with the remaining spoonful of olive oil and add salt and pepper to taste. Sprinkle with paprika. Serve the yogurt as a dip with the potatoes.
5. Serve the potato cubes on a platter and sprinkle with salt. Delicious with a rib eye or with kabobs.

### **Tips**

- Season your fried potato cubes with all kinds of different spices. Mix the oil with ras el hanout or with taco seasoning, for example.

## **Fried Potato Slices with Garlic**

Side dish - 4 persons

⊖ 20 minutes convection oven

500 g waxy potatoes

1 clove garlic, crushed

1 tablespoon fresh thyme

1 tablespoon olive oil

Sea salt

1. Set the convection oven to 482°F. Peel the potatoes and slice them into thin discs. Soak them in water for at least 30 minutes. Drain them thoroughly and pat the tops of the slices dry with kitchen paper.
2. Mix the garlic, thyme and olive oil in a bowl and coat the potatoes in this mixture.
3. Transfer the potato slices to a fryer basket and place the basket into the convection oven. Set the timer to 20-22 minutes and fry the potatoes until they are golden brown and done.
4. Put the fried potato slices on a warm platter and sprinkle with salt. Delicious with lamb chops or cutlets.

## **Roasted Potatoes with Tuna**

Main course - 2 portions

⌚ 30 minutes convection oven

4 starchy potatoes, approximately 125 g each

<sup>1</sup>/<sub>2</sub> tablespoon olive oil

1 can of tuna in oil, drained

2 tablespoons (Greek) yoghurt

1 teaspoon chili powder

1 green onion, finely sliced into rings

Freshly ground black pepper

1 tablespoon capers

1. Soak the potatoes for at least 30 minutes and pat them dry with paper towel.
2. Lightly brush the potatoes with olive oil and place them in the fryer basket. Place the basket into the convection oven and set the timer to 30 minutes & Temperature at 446°F to fry the potatoes until they are deliciously crunchy and done.
3. In a bowl, finely mash the tuna and add the yogurt and chili powder. Mix well. Stir in half of the green onion and season to taste with salt and pepper.
4. Place the potatoes on two plates and cut the top side lengthwise. Slightly push the potato open and spoon the tuna mixture onto the open potato. Sprinkle the filling with chili powder and spoon the capers and the rest of the green onion on top. Delicious with a fresh salad.

### **Tips**

- Serve the roast potatoes as a side dish with a pat of butter or a spoonful of sour cream on top. Sprinkle with coarse sea salt and pepper to taste.

## **Potato Croquettes with Parmesan Cheese**

Side dish - 4 portions

⌚ 30 minutes + 8 minutes convection oven

300 g starchy potatoes, peeled and cubed

1 egg yolk

50 g Parmesan cheese, grated

2 tablespoons flour

2 tablespoons chives, finely chopped  
Freshly ground pepper  
Nutmeg  
2 tablespoons vegetable oil  
50 g bread crumbs

1. Boil the potato cubes in salted water for 15 minutes until ready. Drain the potatoes and mash them finely with a potato masher or a ricer. Allow the mashed potatoes to cool.
2. Add the egg yolk, cheese, flour and chives to the potato puree and mix well. Season to taste with salt, pepper and nutmeg.
3. Set the convection oven to 446°F. Mix the oil and the bread crumbs and keep stirring until the mixture becomes loose and crumbly again.
4. Shape the potato puree into 12 croquettes and roll them through the bread crumbs until they are completely coated.
5. Put six croquettes in a fryer basket and place the basket into the convection oven. Set the timer to 5-8 minutes and fry the potato croquettes until they are crispy brown. Then fry the rest of the croquettes.

### **Tips**

- If you wet your hands slightly before shaping the croquettes, the puree forms easily into smooth croquettes.
- Double the croquette recipe and freeze half of the prepared unfried croquettes for another time.

### **Rösti**

Appetizer - 4 portions

⌚ 10 minutes + 15 minutes airfryer

250 g waxy potatoes, peeled  
1 tablespoon chives, finely chopped  
Freshly ground black pepper  
1 tablespoon olive oil  
2 tablespoon sour cream  
100 g smoked salmon

1. Preheat the convection oven to 392°F. Coarsely grate the potatoes into a bowl and add three-quarters of the chives and salt and pepper to taste.

Mix well.

2. Grease a small pizza pan with olive oil and distribute the potato mixture evenly in the pan. Press the grated potatoes into the pan and brush the top of the potato cake with olive oil.
3. Place the pizza pan in the convection oven. Set the timer to 15-18 minutes and fry the rösti until it is nicely browned on the outside and soft and done on the inside.
4. Cut the rösti into 4 quarters and place each quarter on a plate. Garnish with a spoonful of sour cream and put the slices of salmon on the plate next to the rösti. Sprinkle the rest of the chives over the sour cream and add a touch of ground pepper.

### **Tips**

- The rösti is also delicious as a side dish for 2 people.

### **Feta Triangles**

Appetizer - 15 portions

🕒 20 minutes + 9 minutes convection oven

1 egg yolk

100 g feta

2 tablespoons flat-leaved parsley, finely chopped

1 green onion, finely sliced into rings

Freshly ground black pepper

5 sheets of frozen filo pastry, defrosted

2 tablespoons olive oil

1. Beat the egg yolk in a bowl and mix the feta, parsley and green onion; season with pepper to taste.
2. Cut each sheet of filo pastry into three strips.
3. Scoop a full teaspoon of the feta mixture on the underside of a strip of pastry. Fold the tip of the pastry over the filling to form a triangle, folding the strip zigzag until the filling is wrapped up in a triangle of pastry. Fill the other strips of pastry with feta in the same manner.
4. Preheat the convection oven to 428°F.
5. Brush the triangles with a little oil and place five triangles on the Wire rack. Put the wire rack into the convection oven and set the timer to 3-5 minutes. Bake the feta triangles until they are golden brown. Bake the other feta triangles in the same manner.



6. Serve the triangles on a platter.

## **Salmon Croquettes**

Appetizer - 8 portions

🕒 10 minutes + 8 minutes convection oven

1 tin of red salmon (approx. 200 g), drained

1 egg, lightly beaten

1 tablespoon fresh dill, finely chopped

2 tablespoons chives, finely chopped

Freshly ground pepper

50 g bread crumbs

2 tablespoons oil

1. Preheat the convection oven to 446°F
2. With a fork, mash up the salmon in a deep dish and mix it with the egg and herbs. Season the mixture to taste with pepper and salt.
3. Mix the bread crumbs with the oil in another deep dish until you obtain a loose mixture.
4. Shape the salmon mixture into eight small croquettes and coat them in the bread crumb mixture.
5. Put the croquettes in a basket and place the basket into the convection oven. Set the timer to 8-10 minutes and bake the croquettes until golden brown.

## **Meatballs with Feta**

Appetizer - 10 minutes

🕒 10 minutes + 8 minutes convection oven

150 g lamb mince or lean minced beef

1 slice of stale white bread, turned into fine crumbs

50 g Greek feta, crumbled

1 tablespoon fresh oregano, finely chopped

<sup>1/2</sup> tablespoon grated lemon peel

Freshly ground black pepper

Round, shallow oven dish, approx. 15 cm

Tapas forks

1. Mix the mince in a bowl with the bread crumbs, feta, oregano, lemon

- peel and black pepper, thoroughly kneading everything together.
2. Divide the mince into 10 equal portions and form smooth balls, using damp hands.
  3. Put the balls in the oven dish and place this dish on the wire rack. Put them into the convection oven. Set the timer to 8-10 minutes & Temperature at 482°F and bake the mince balls until they are nicely brown and done.
  4. Serve the meatballs hot in a platter with tapas forks.

### **Tips**

- Prick the meatballs onto a tapas fork with half a black olive and a strip of roasted bell pepper.
- Or you can use a basket to fry the balls.

### **Ricotta Balls with Basil**

Appetizer - 20 portions

⌚ 15 minutes + 16 minutes convection oven

250 g ricotta

2 tablespoons flour

1 egg, separated

Freshly ground pepper

15 g fresh basil, finely chopped

1 tablespoon chives, finely chopped

1 tablespoon grated orange peel

3 slices of stale white bread

1 tablespoon olive oil

1. Mix the ricotta in a bowl with the flour, egg, yolk, 1 teaspoon salt and freshly ground pepper. Stir the basil, chives and orange peel through the mixture.
2. Divide the mixture into 20 equal portions and shape them into balls with wet hands. Let the balls rest for a while.
3. Grind the bread slices into fine bread crumbs with the food processor and mix with the olive oil. Pour the mixture into a deep dish. Briefly beat the egg white in another deep dish.
4. Preheat the convection oven to 446°F
5. Carefully coat the ricotta balls in the egg white and then in the bread crumbs.

- Put 10 balls on the wire rack into the convection oven. Set the timer to 8-10 minutes. Bake the balls until golden brown. Bake the rest of the balls in the same way.
- Serve the ricotta balls on a platter.

### **Tips**

- Mix some freshly ground chili flakes through the ricotta mixture for spicier balls. Color the bread crumbs red in that case by adding two to three teaspoons of paprika to the olive oil.

## **Mini Frankfurters in Pastry**

Appetizer - approx. 20 portions

⌚ 10 minutes + 20 minutes convection oven

1 tin of mini frankfurters (drained weight 220 g, approx. 20 frankfurters)

100 g (chilled or frozen, defrosted) ready-made puff pastry

1 tablespoon fine mustard

- Preheat the convection oven to 428°F
- Thoroughly drain the sausages on a layer of kitchen paper and dab them dry.
- Cut the puff pastry into strips measuring 5 X 1<sup>1/2</sup> cm and coat the strips with a thin layer of mustard.
- Roll each sausage spirally into a strip of pastry.
- Put half the sausages in pastry in the wire rack and put them into the airfryer. Set the timer to 10-12 minutes. Bake the sausages in pastry until golden brown. Bake the remaining sausages in the same manner.
- Serve the sausages on a platter accompanied by a small dish of mustard.

## **Mini Empanadas with Chorizo**

Appetizer - 20 minutes

⌚ 20 minutes + 20 minutes convection oven

125 g chorizo, in small cubes

1 shallot, finely chopped

<sup>1/4</sup> red bell pepper, diced into small cubes

2 tablespoons parsley

200 g chilled pie crust dough (pâte brisée) or pizza dough

1. Stir the chorizo with the shallot and bell pepper in a skillet and fry on low heat for 2 to 3 minutes until the bell pepper is tender. Take off the heat and stir in the parsley. Allow the mixture to cool.
2. Preheat the convection oven to 392°F
3. Use a glass to cut twenty 5 cm rounds from the dough. Scoop a spoonful of the chorizo mixture onto each round. Press the edges together between thumb and index finger, creating a scallop pattern.
4. Put 10 empanadas in a basket and place the basket into the convection oven. Set the timer to 10-12 minutes and bake the empanadas until they are golden brown and done.
5. Bake the remaining empanadas in the same way. Serve the empanadas lukewarm.

## **King Prawns in Ham with Red Pepper Dip**

Appetizer - 10 portions

⊖ 15 minutes + 13 minutes convection oven

1 large red bell pepper, halved

10 (frozen) king prawns, defrosted

5 slices of raw ham

1 tablespoon olive oil

1 large clove garlic, crushed

<sup>1/2</sup> tablespoon paprika

Freshly ground black pepper

Tapas forks

1. Preheat the convection oven to 446°F. Put the bell pepper in a basket and place it into the convection oven. Set the timer to 10 minutes. Roast the bell pepper until the skin is slightly charred. Put the bell pepper in a bowl and cover it with a lid or cling film. Let the bell pepper rest for 15minutes.
2. Peel the prawns, make an incision in the back and remove the black vein. Halve the slices of ham lengthwise and wrap each prawn in a slice of ham.
3. Coat the parcels with a thin film of olive oil and put them in the basket. Place the basket into the convection oven and set the timer to 3-5 minutes. Fry the prawns until crispy and just right.

4. In the meantime, peel the skin off the bell pepper halves, remove the seeds and cut the pepper into pieces. Puree the bell pepper in the blender with the garlic, paprika and olive oil. Pour the sauce into a dish season with salt and pepper to taste.
5. Serve the prawns with ham on a platter with tapas forks and add the small dish with red pepper dip.

### **Tips**

- Replace the red pepper dip with ready-made puree, mixed with garlic. Or serv e the prawns with garlic mayonnaise.

## **Mini Peppers with Goat Cheese**

Appetizer - 8 portions

⊖ 10 minutes + 8 minutes convection oven

8 mini or snack peppers

<sup>1/2</sup> tablespoon olive oil

<sup>1/2</sup> tablespoon dried Italian herbs

1 teaspoon freshly ground black pepper

100 g soft goat cheese, in eight pieces

1. Preheat the convection oven to 428 F.
2. Cut the top of the mini peppers and remove the seeds and membrane.
3. Mix the olive oil in a deep dish with the Italian herbs and the pepper. Toss the pieces of goat cheese in the oil.
4. Push a piece of goat cheese in each mini pepper and place the mini peppers next to each other onto the wire rack. Put them into the convection oven and set the timer to 8-10 minutes. Bake the mini peppers until the cheese has melted.
5. Serve the mini peppers in small dishes as appetizers or snacks.

### **Tips**

- The same method can be used to fill vine tomatoes. Hollow out the tomatoes first and leave them to drain upside down on kitchen paper.

## **Garlic Mushrooms**

Appetizer - 12 portions

⊖ 10 minutes + 10 minutes convection oven

1 slice of white bread

1 clove garlic, crushed  
1 tablespoon flat-leafed parsley, finely chopped  
Freshly ground black pepper  
1 tablespoon olive oil  
12 (chestnut) mushrooms

1. Preheat the convection oven to 392°F.
2. Grind the slices of bread into fine crumbs in the food processor and mix in the garlic, parsley and some seasoning to taste. Lastly, stir in the olive oil.
3. Cut off the mushroom stalks and fill the caps with the bread crumbs.
4. Put the mushroom caps in a basket and place it into the convection oven. Set the timer to 10-12 minutes. Bake the mushrooms until crispy and golden.
5. Serve the mushrooms on a platter.

### **Tips**

- Alternatively, mix the bread crumbs with strips of ham, green onion and grated cheese.

## **Spicy Drumsticks with Barbecue Marinade**

Main course - 4 portions

⊖ 5 minutes (+ 20 min to marinade) + 10 minutes convection oven

1 clove garlic, crushed  
<sup>1</sup>/<sub>2</sub> tablespoon mustard  
2 teaspoons brown sugar  
1 teaspoon chili powder  
Freshly ground black pepper  
1 tablespoon olive oil  
4 drumsticks

1. Preheat the convection oven to 428°F.
2. Mix the garlic with the mustard, brown sugar, chili powder, a pinch of salt and freshly ground pepper to taste. Mix with the oil.
3. Rub the drumsticks completely with the marinade and leave to marinate for 20 minutes.
4. Put the drumsticks onto the wire rack and put them into the convection oven. Set the timer to 10-12 minutes. Roast the drumsticks until brown.

5. Serve the drumsticks with corn salad and French bread.

### **Tips**

- Corn Salad

Serve the drumsticks with a refreshing corn salad. Drain a can of corn kernels (300 gram). Cut four tomatoes into four sections and remove the seeds. Cut the flesh of the tomatoes into cubes. Mix the corn with the tomato cubes, 1 finely sliced green onion, the juice of half a lime, 2 tablespoons fresh, coarsely chopped coriander, and some salt and freshly ground chili pepper to taste.

- Chicken legs

This marinade is also great for chicken legs, You can roast two chicken legs at a time in the convection oven, first 10 minutes at 428°F .

## **Roasted Asian Chicken Wings**

Main course - 4 portions

⊖ 5 minutes + 10 minutes convection oven

2 cloves garlic

2 teaspoons ginger powder

1 teaspoon ground cumin

Freshly ground black pepper

500 g chicken wings at room temperature

100 ml sweet chili sauce

1. Preheat the convection oven to 428°F
2. Mix the garlic with the ginger powder, cumin, plenty of freshly ground black pepper and some salt. Rub the chicken wings with the herbs
3. Put the chicken wings onto the wire rack and put them into the convection oven. Set the timer to 10-12 minutes and roast the chicken wings until they are crispy brown.
4. Serve the chicken wings with the chili sauce as a main course or a snack.

### **Tips**

- Serve the chicken wings as a main course with stir-fried noodles and bak choy. Boil 250 g noodles until al dente. Stir-fry 3 green onions and 1 bunch of bak choy cut in broad strips in a wok with 2 tablespoons of oil for 2-3 minutes. Spoon in the noodles and season to taste with soy sauce.
- The chicken wings are also very taste as a snack.

## **Pork Satay with Peanut Sauce**

Main course - 2-3 portions

⌚ 20 minutes (+15 min to marinade) + 12 minutes convection oven

2 cloves garlic, crushed

2 cm fresh ginger root, grated or 1 teaspoon ginger powder

2 teaspoons chili paste or hot pepper sauce

2-3 tablespoons sweet soy sauce

2 tablespoons vegetable oil

400g lean pork chops, in cubes of 3 cm

1 shallot, finely chopped

1 teaspoon ground coriander

200 ml coconut milk

100 g unsalted peanuts, ground

1. Mix half of the garlic in a dish with the ginger, 1 teaspoon hot pepper sauce, 1 tablespoon soy sauce, and 1 tablespoon oil. Mix the meat with the mixture and leave to marinate for 15 minutes.
2. Preheat the convection oven to 428°F
3. Put the marinated meat onto the wire rack and put them into the convection oven. Set the timer to 12-14 minutes and roast the meat until brown and done. Turn once while roasting.
4. In the meantime, make the peanut sauce: heat 1 tablespoon oil in a saucepan and gently sauté the shallot with the remainder of the garlic. Add the coriander and fry for a short time more.
5. Mix the coconut milk and the peanuts with 1 teaspoon hot pepper sauce and 1 tablespoon soy sauce with the shallot mixture and gently boil for 5 minutes, while stirring. If necessary, add a little bit of water if the sauce gets too thick. Season to taste with soy sauce and hot pepper sauce.

## **Mediterranean Chicken Nuggets**

Main course - 4 portions

⌚ 20 minutes + 20 minutes convection oven

2 slices stale white bread, in pieces

1 tablespoon (spicy) paprika powder

1 tablespoon olive oil



250 g chicken fillet, in pieces  
1 egg yolk + 2 egg whites  
1 clove garlic, crushed  
2 tablespoons red pesto  
Freshly ground pepper  
1 tablespoon flat-leafed parsley, finely chopped

Food processor

1. Grind the bread with the paprika powder in the food processor until you have a crumbly mixture and mix in the olive oil. Transfer this mixture to a bowl.
2. Then purée the chicken fillet in the food processor and mix with the egg yolk, garlic, pesto, and parsley. Add <sup>1/2</sup> teaspoon salt and pepper to taste.
3. Preheat the convection oven to 428°F
4. Whisk the egg whites in a bowl. Shape the chicken mixture into 10 balls and press them into oval nuggets. Coat the nuggets first with egg white and then with breadcrumbs. The nuggets must be coated with crumbs all over.
5. Put five nuggets in the basket and place it into the convection oven. Set the timer to 10-12 minutes. Fry the nuggets golden brown. Then fry the remainder of the nuggets. Delicious with French fries and a fresh salad.

### Tips

- You can make variations of these Mediterranean chicken nuggets. Make Italian nuggets with green pesto and 25 g Parmesan cheese, or Greek nuggets with grated lemon peel, finely chopped oregano and 25 g crumbled feta cheese.

## Thai Fish Cakes with Mango Salsa

Main course - 4 portions

⌚ 20 minutes + 14 minutes convection oven

1 ripe mango  
1 <sup>1/2</sup> teaspoons red chili paste  
3 tablespoons fresh coriander or flat leaf parsley  
Juice and zest of 1 lime  
500 g white fish fillet (cod, tilapia, pangasius, pollack)  
1 egg

1 green onion, finely chopped  
50 g ground coconut

Food processor

1. Peel the mango and cut it into small cubes. Mix the mango cubes in a bowl with  $\frac{1}{2}$  teaspoon red chili paste, 1 tablespoon coriander and the juice and zest of half a lime.
2. Purée the fish in the food processor and then mix with 1 egg and 1 teaspoon salt and the remainder of the lime zest, red chili paste and the lime juice. Mix with the remainder of the coriander, the green onion and 2 tablespoons coconut.
3. Put the remainder of the coconut on a soup plate. Divide the fish mixture into 12 portions, shape them into round cakes and coat them with the coconut.
4. Place six fish cakes onto the wire rack and put them into the convection oven at 392°F. Set the timer to 7-10 minutes and fry the fish cakes until they are golden brown and done. Fry the remainder of the fish cakes in the same way.
5. Serve the fish cakes with the mango salsa. Tasty with pandan rice and stir-fried pak choi.

## **Meat Loaf**

Main course - 4 portions

⌚ 10 minutes + 20 minutes convection oven

400 g (lean) ground beef

1 egg, lightly beaten

3 tablespoons bread crumbs

50 g salami or chorizo sausage, finely chopped

1 small onion, finely chopped

1 tablespoon (fresh) thyme

Freshly ground pepper

2 mushrooms, thick slices

1 tablespoon olive oil

Fixed-bottom baking pan or round oven dish,  
12 cm diameter, contents 500 ml

1. Preheat the convection oven to 446°F
2. Mix the ground meat in a bowl with the egg, bread crumbs, salami, onion, thyme, 1 teaspoon salt and a generous amount of pepper. Knead and mix thoroughly.
3. Transfer the ground meat to the pan or dish and smoothen the top. Press in the mushrooms and coat the top with olive oil.
4. Place the pan or dish onto the wire rack and put them into the convection oven. Set the timer to 20-25 minutes and roast the meat loaf until nicely brown and done.
5. Leave the meat loaf to stand for at least 10 minutes before serving. Then cut the loaf into wedges. Tasty with fried potatoes and a salad.

## **Courgette Stuffed with Ground Meat**

Main course - 2 portions snack – 4 portions

⊖ 20 minutes + 20 minutes convection oven

1 large courgette (approx. 400 g)

50 g feta cheese, crumbled

1 clove garlic, crushed

<sup>1</sup>/<sub>2</sub> tablespoon mild paprika powder

200 g lean ground beef

Freshly ground black pepper

Shallow bowl, diameter approx. 15 cm

1. Cut the ends off the courgette and cut it into six equal parts. Set the parts upright and carve them out with a teaspoon to <sup>1</sup>/<sub>2</sub> cm off the sides and 1 cm off the bottom. Sprinkle the inside with a little salt.
2. Preheat the convection oven to 428°F
3. Mix the ground beef with the feta cheese, garlic, paprika powder and pepper to taste and mix well. Divide the ground beef into six equal portions. Fill the hollow courgette parts with ground beef and press in the mixture. Smooth the top with a moist hand.
4. Put the courgette in the bowl and place the bowl onto the wire rack. Put them into the convection oven and set the timer to 20 minutes. Bake the stuffed courgette until it is brown and done. Delicious with yellow rice and roasted cherry tomatoes.

## Tips

- Roasted cherry tomatoes

Place 250 g cherry tomatoes on the vine in the basket and roast them in the airfryer for 3-4 minutes at 446°F. The tomatoes are ready when the skin breaks. Arrange one or two clusters of tomatoes on each plate next to the stuffed courgettes.

## Brownies

Pastry - 12 portions

⊖ 15 minutes + 20 minutes convection oven

75 g pure chocolate, in pieces

75 g butter

1 large egg

60 g sugar

1 sachet vanilla sugar

40 g self-rising flour

25 g walnuts or hazelnuts, chopped

Small, low fixed-base cake tin or oven dish, (approx. 15 cm diameter) and parchment paper

1. Melt the chocolate and butter together in a thick-bottom steel pan on low heat while stirring. Allow this mixture to cool to room temperature.
2. Preheat the convection oven to 392°F
3. In a bowl, beat the egg with the sugar, the vanilla sugar and a pinch of salt until light and creamy. Beat in the chocolate mixture and then stir in the self-rising flour and the nuts.
4. Line the cake pan with parchment paper and spread the batter in the cake pan. Smooth the top.
5. Place the cake pan onto the wire rack and put them into the convection oven. Set the timer to 20-22 minutes and bake the brownie until the top is crispy. The inside should still be nice and soft.

# Salmon Quiche

Main course - 2 portions

⊖ 15 minutes + 20 minutes convection oven

150 g salmon fillet, cut into small cubes

<sup>1</sup>/<sub>2</sub> tablespoon lemon juice

Freshly ground black pepper

100 g flour

50 g cold butter, in cubes

2 eggs + 1 egg yolk

3 tablespoons whipping cream

<sup>1</sup>/<sub>2</sub> tablespoon (tarragon) mustard

1 green onion, sliced into 1 cm pieces

Small, low quiche pan, approx. 15 cm diameter, buttered

1. Preheat the convection oven to 392°F. Mix the salmon pieces with the lemon juice and salt and pepper to taste. Allow the salmon to rest.
2. In a bowl, mix the flour with the butter, egg yolk and <sup>1</sup>/<sub>2</sub> – 1 tablespoon cold water and knead into a smooth ball.
3. On a floured work surface, roll out the dough to an 18 cm round.
4. Put the dough round in the quiche pan and press firmly along the edges. Trim the dough closely along the edge of the pan or allow the dough to stick out roughly over the edges of the pan.
5. Beat the eggs lightly with the cream and mustard and add salt and pepper to taste. Pour this mixture into the quiche pan and then lay the pieces of salmon in the pan. Distribute the green onion evenly over the contents of the quiche pan.
6. Place the quiche pan onto the rack and put them into the convection oven. Set the timer to 20 minutes and bake the quiche until golden brown and done.

**TAYAMA APPLIANCE USA INC.**

[www.tayama.usa.com](http://www.tayama.usa.com)