

# Assembly Instructions

## D-AB268PWD

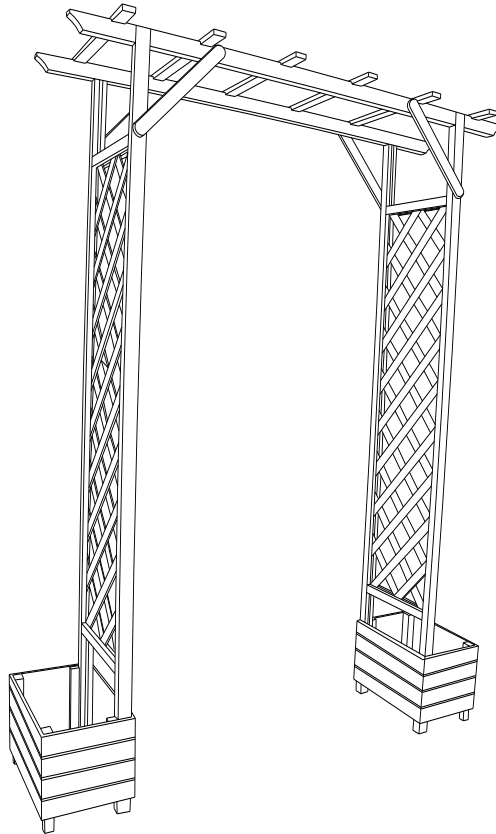

**WARNING:**

Repeated assembly can weaken the locking ability of the screw/bolt/nut. Periodically check all bolted connections on your product to make sure they are tight and secure. Keep these instructions for future reference.

Some parts may contain sharp edges. Wear protective gloves as necessary.

Set it up on the level ground.

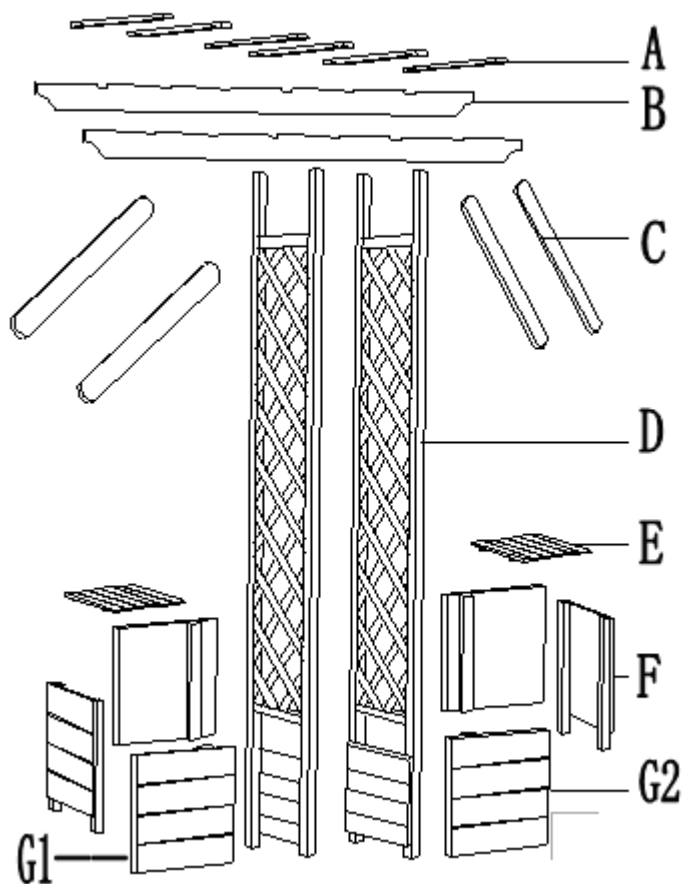

**Attention:** There may have slots on the product, this is not inferior, it is nature of the wood item, this is to allow the wood to naturally shrink and expand.

Part#	Description	Qty.
A	Cross beam	6
B	Beam	2
C	Corner connector	4
D	Screen	2
E	Baseboard	2
F	Sideboard	2
G1	Frontboard	2
G2	Backboard	2

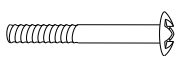
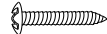
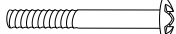

### Hardware pack

Part#	Description	Qty.	Image
AA	Screw M6x60	24	
BB	Screw M4x25	12	
CC	Bolt M6x40	4	

Part#	Description	Qty.	Image
DD	Washer M6	28	
EE	Nut M6	28	

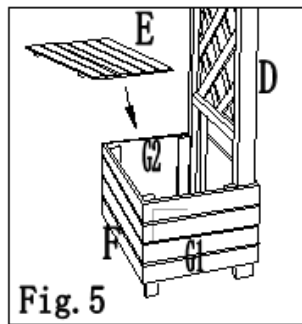
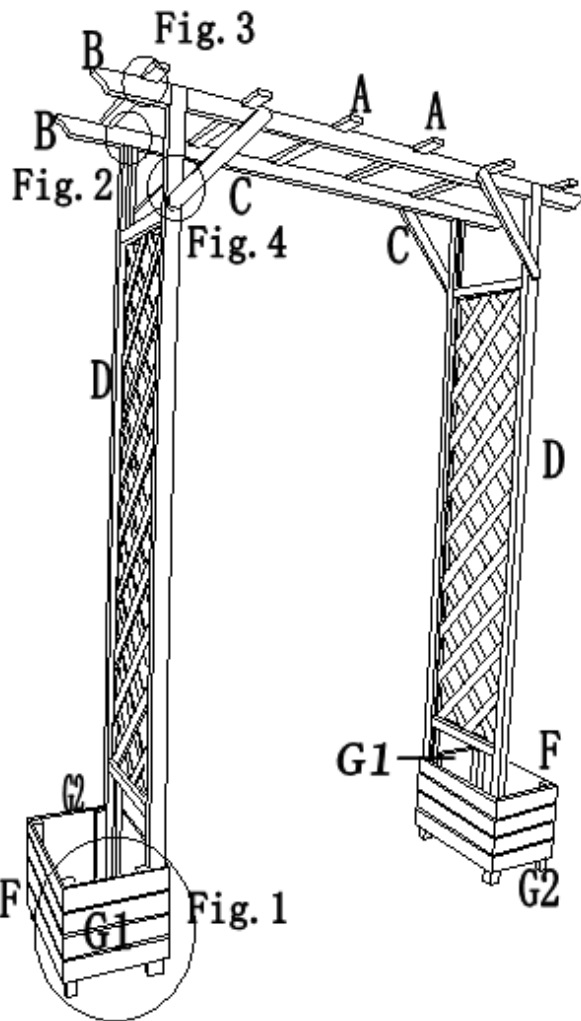
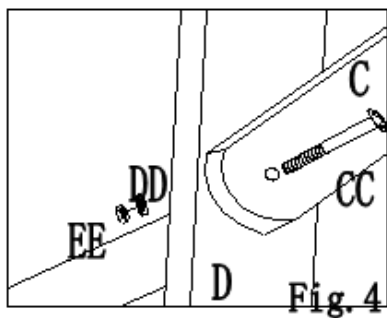
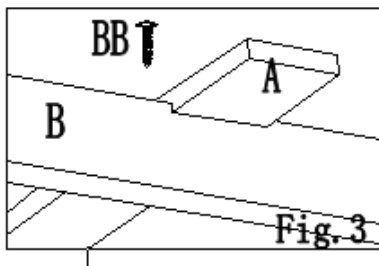
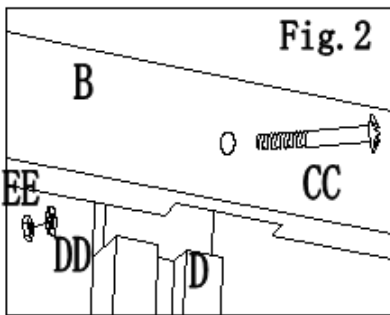
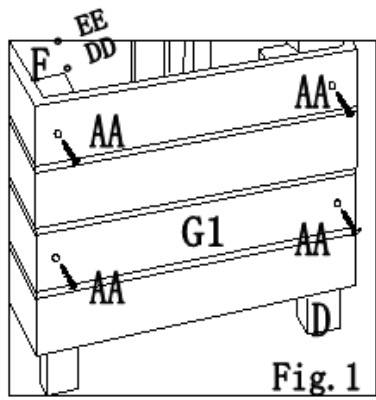

**Fig.1:** Attach Frontboard (G1), Backboard (G2) to Screen (D) with Screw AA, then attach Sideboard (F) to boards G1/G2 with AA as Fig.1 shown.

**Fig.2:** Attach Beam (B) to Screen (D) with Bolt (CC), Washer (DD) and Nut (EE) as Fig. 2 shown.

**Fig.3:** Fix Cross beam (A) to Beam (B) with Screw (BB) as Fig. 3 shown.

**Fig.4:** Attach Corner connector (C) to Beam (B) and Screen (D) with Bolt (CC), Washer (DD) and Nut (EE) as Fig. 4 shown.

**Fig. 5:** Place Baseboard (E) into the pre-assembled planter as arrow directed on Fig. 5.

**Now, the arbor is ready to use!**

**Limited Warranty:**

This limited warranty is extended to the original purchaser and applies to defects in materials and workmanship of your item provided the item is maintained with care and used only for personal, residential purposes. The item is warranted to be free from defects in material or workmanship for a period of six (6) months. We don't reimburse for transportation or delivery costs, or compensate the individual or any outside party for assembling or disassembling the product.

**Exclusions:**

Items used for commercial, contract, or other non-residential purposes, or items damaged due to acts of nature, vandalism, misuse, or improper assembly are not covered. Corrosion or rusting of hardware is not covered. Proof of purchase (dated register receipt) is required for warranty claims. Warranty is to the original purchaser and is non-transferable. Any replacement of warranted items will be in the original style and color, or a similar style and color if the original is unavailable or has been discontinued. As some states do not allow exclusions or limitations on an implied warranty, the above exclusions and limitations may not apply. This warranty gives you specific rights, and you may also have other rights, which vary from state to state.

**Important:**

For technical assistance on assembly or replacement parts. In the continental U.S., you can call us toll-free at 1-866-578-6569 from 8 a.m. to 5 p.m. CST Monday – Friday. In the continental Canada, you can call us toll-free at 1-844-SUNJOY1 (1-844-786-5691) from 8 a.m. to 5 p.m. CST Monday – Friday. You can fax the replacement part form which is in the box to (740)-283-3549 . You can also send us an email to [customer.care@sunjoygroup.com](mailto:customer.care@sunjoygroup.com). The manufacturer reserves the right to repair or replace the defective product, at its discretion.

Made in China