

Use and Care Guide Dorm Space Saver

Item #SL-SSHD-34C
Model #000000000

HDX™

PACKAGE CONTENTS

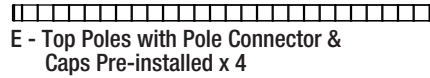
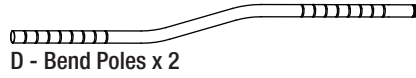
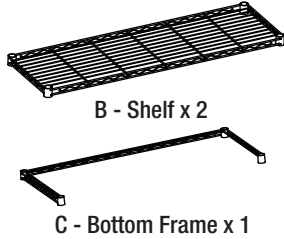
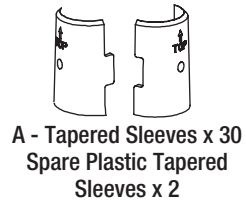

Assembly

1 Assembling the bottom frame

- Locate the desired position of the bottom frame (C). Ensure that it is no more than 6 in. from the floor.
- Place two tapered sleeves (A) into the appropriate groove on each pole assembly. Ensure the tapered end is up (see arrow on sleeve).
- Place the bottom frame (C) on its side and slide the each pole assembly with tapered locks through the bottom of the frame (C) until snug.
- After all pole assemblies are in place, position the unit in the upright position.
- Push down on each corner of the frame (C), ensure the frame (C) is in a fully locked position.

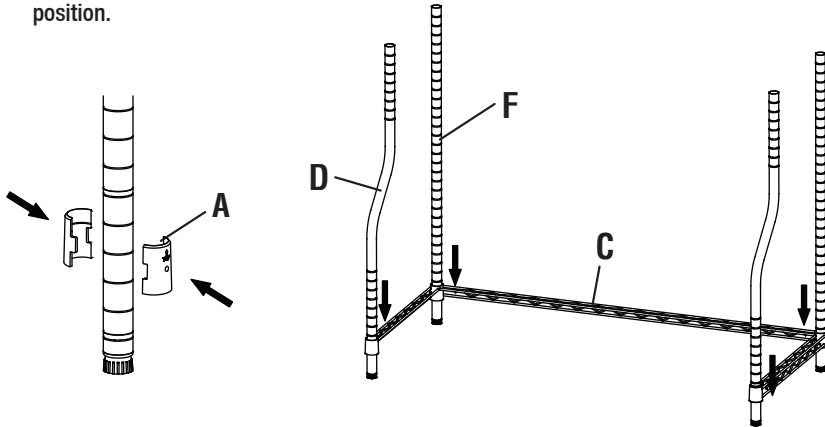

3 Assembling the posts

- Screw a top pole (E) to a bottom pole (F) & bend pole (D).

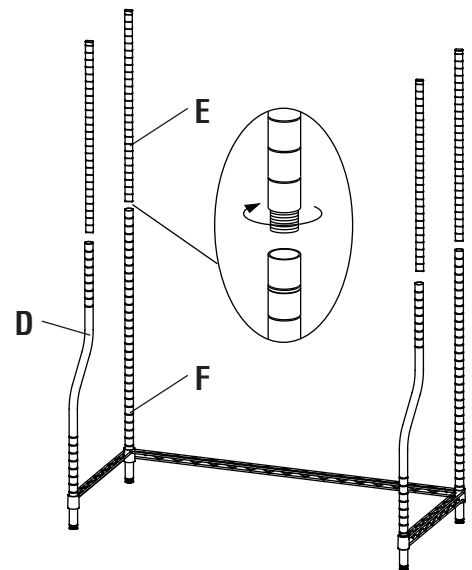

4 Assembling the Racks

- Locate the desired position of the cup holder (G), book rack (H) & coat rack (I). Place the tapered sleeves (A) on to the pole assemblies.
- Slide the cup holder (G) down from the top of the pole assemblies and onto the tapered sleeves (A). Repeat for the remaining book rack (H) & coat rack (I).

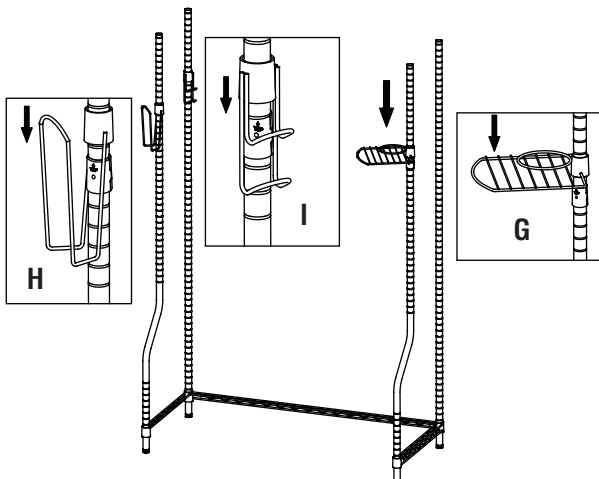

5 Assembling the Shelf

- Locate the desired position of the shelf (B) and place the tapered sleeves (A) on to the pole assemblies.
- Slide the shelf (B) down from the top of the pole assemblies and onto the tapered sleeves (A).
- Push down on each shelf (B) corner, ensuring the shelf (B) is in a fully locked position.
- Repeat for the remaining shelf (B).

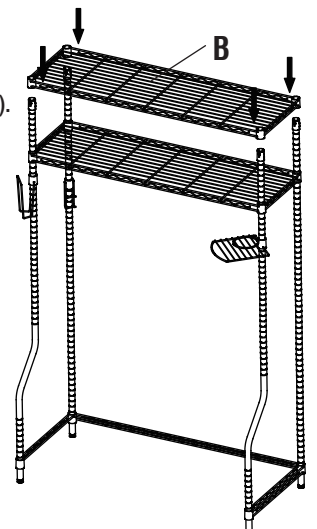

Safety Information

- Two adults are recommended for ease of assembly. Use care when handling.
- Assembly recommended on a soft surface, such as carpet, to avoid scratching flooring finish.
- Discard the black circular plastic pieces. These are used to separate the shelves for shipping purposes.



CAUTION: Do not allow children to climb or play in or around the shelves.



CAUTION: Each shelf holds up to 150 lbs, evenly distributed. Do not overload.



HOMEDEPOT.COM
Please contact 1 (855) 439-4663 for further assistance.
customer.solutions@yahoo.com
Between 8 a.m and 17 p.m(Central Time) Monday to Friday