

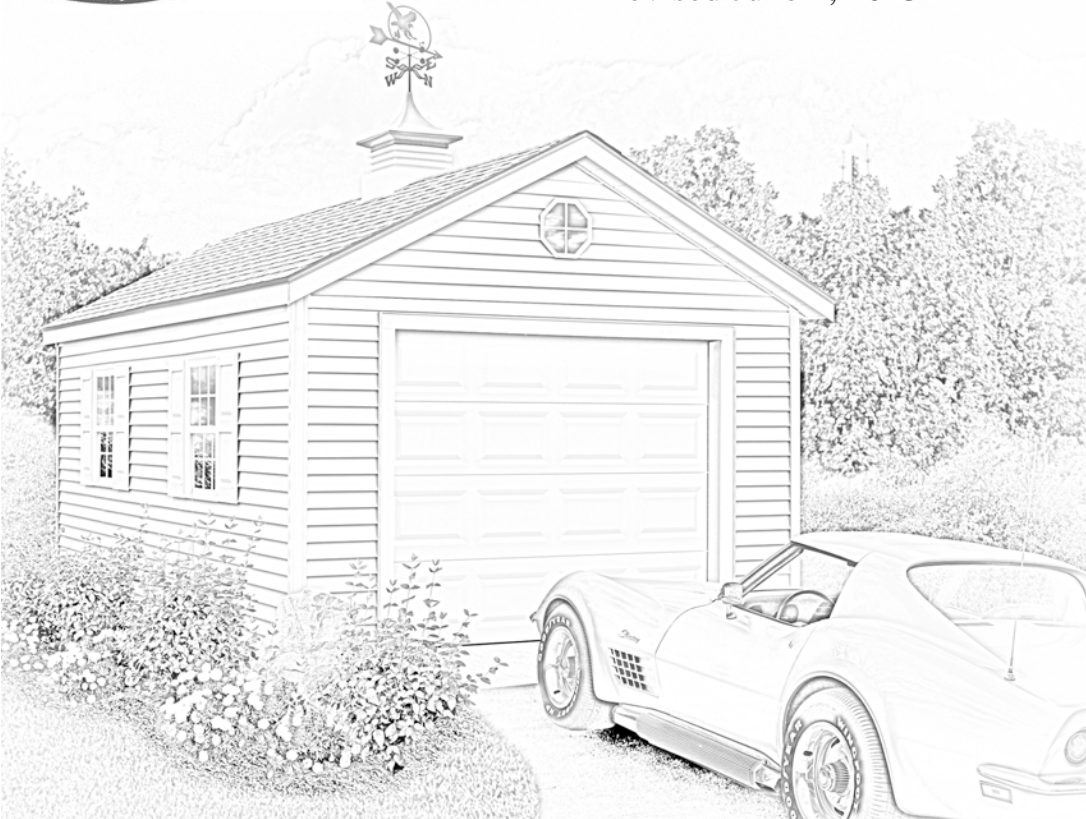

Best Barns USA Assembly Book

Revised June 4, 2013



the Greenbriar 12' x 16'

Manufactured by Reynolds Building Systems, Inc.

205 Arlington Drive

Greenville, PA 16125

724-646-3775

This manual is copyrighted. Under the copyright laws, this manual may not be copied, in whole or in part, without consent from Reynolds Building Systems, Inc. © Copyright 2012

IMPORTANT INFORMATION ABOUT YOUR SHED KIT

Thank you for purchasing our Greenbriar kit. These instructions will construct a 12'x16' building. **If you received two books, use the one with the latest revision date.**

The material that is included in our kit is listed on the back page. The optional floor package, *if ordered*, will be supplied by a local lumber supplier.

The door opening is for a 8' wide x 7' high garage door. You will need to order your garage door with an 9" low headroom kit.

Our framing lumber is imported to provide you the highest quality available. However, if you need to replace any lumber for any reason please do so and we will reimburse you.

The foundation size should measure 12'-0" wide by 16'-0". **Do Not** make the foundation larger than the building size. The siding should project beyond the foundation for water to expel properly from the sidewalls.

IMPORTANT: Unpack the material from the pallet, then disassemble the pallet. The bit for the screws is packed in the hardware bag. Remove the OSB panel from the pallet, it will be used for roof sheathing. The 2x4s will be used for wall bracing.

When building the trusses, our instructions suggest using the floor as a work area. If your foundation is a concrete slab it will not be possible to use this method. Build the 12' long back wall to use as a platform. If you do not want to screw blocks into the siding you can temporarily tack OSB sheathing to the back wall frame.

The LP siding has a 50 year warranty and is already primed. Apply two coats of latex acrylic paint for the finish coat. Paint the bottom edge of the siding, this is very important. Maintain 6" to 8" of clearance from the bottom edge of the siding and the ground. Don't allow garden mulch to build up and keep shrubs a minimum of 1' away from the building.

If you have any questions about assembling the kit, call 800-245-1577. If you are calling after normal business hours, call 724-866-HELP (4357) or email to help@barnkits.com.

Before you begin construction, be sure to study this assembly manual. Also, obtain a building permit and check all pertinent building code regulations.

Thank you for your purchase.

Bill & Linda Rinella, owners

Tool List

- | | |
|--|---|
| <input type="checkbox"/> Hammer & Phillips Screwdriver | <input type="checkbox"/> Power Drill/Screwdriver |
| <input type="checkbox"/> Framing Square & Level | <input type="checkbox"/> Measuring Tape & Chalkline |
| <input type="checkbox"/> Circular Saw and/or Hand Saw | <input type="checkbox"/> 2-8' Step Ladders |

Always wear safety glasses when cutting or nailing!

Optional Wood Floor System

Shown below is a typical wood floor. Depending on your area, the construction may have to be changed to meet local codes. The foundation size should be 12' - 0" x 16' - 0".

1. Cut (2) two treated 2x4-8' boards in half.
2. Butt 4x4-8' treated runners together. Use one of the 4' long 2x4s to secure them together. Note: Use 16d galv. nails to secure all treated framing together.
3. Repeat to join the other 4x4 runners.

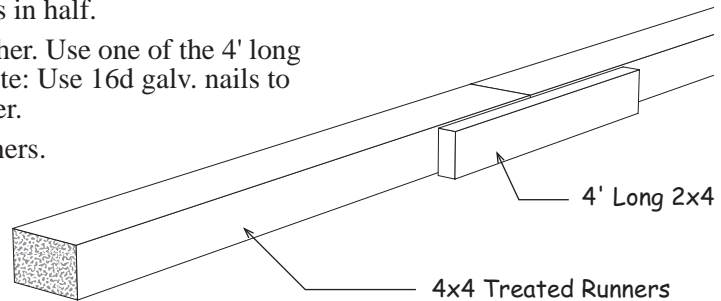

4. Cut (2) two 2x4-16' joist headers to 16' - 0".
5. Layout for 12" on center joist spacing. 'X' marks where floor joist will be placed.

Detail 1

2x4 - 16' 0"
Joist Header

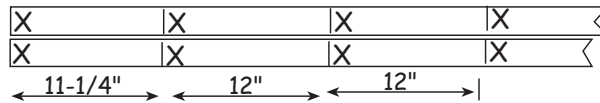

6. Cut all the 2x4-12' boards to 11'-9". These boards will be the floor joist. *Treated lumber may be thicker than 1-1/2". Take this into account when cutting the length of floor joists. Shorten joist measurements if necessary to obtain 12'-0" building width.*
7. Install floor joist boards between the joist headers. Install this section over 4x4s.

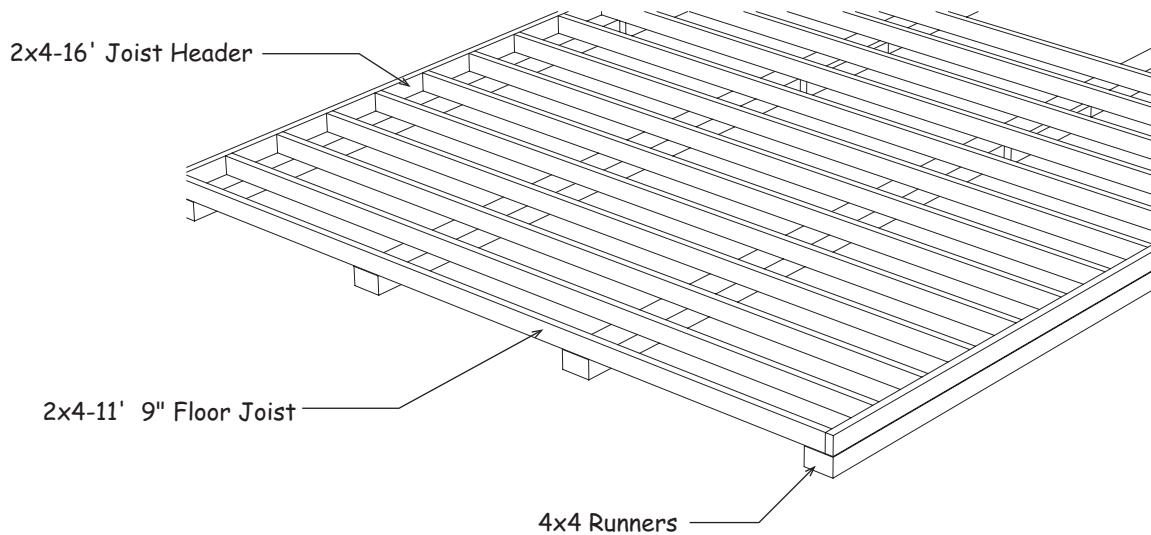

Optional Wood Floor System

8. It is important that the floor be level and square. Square the floor as follows: before nailing the flooring, measure the floor diagonally (corner to corner). Then measure the opposite corners. These measurements will be the same if the floor is square. The diagonal measurement should be 20' - 0". Nail several floor joist to the 4x4 runners to hold the floor frame in place.

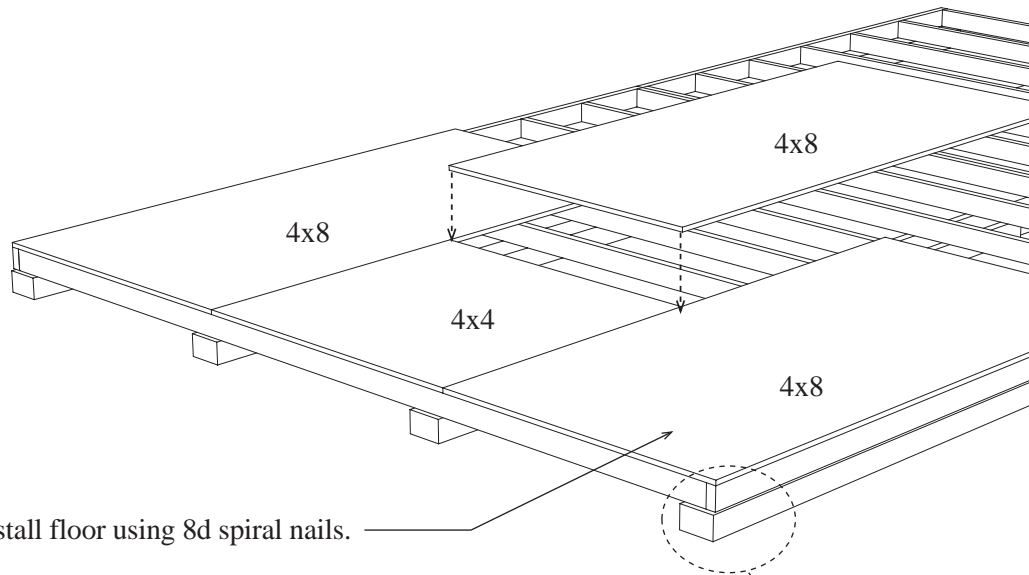

9. Install floor using 8d spiral nails.

| Material Description | 12' x 16' shed |
|-----------------------------|-----------------------|
| 2x4 Treated | 2 pcs. 8' |
| 2x4 Treated | 17 pcs. 12' |
| 2x4 Treated | 2 pcs. 16' |
| 4x4 Treated Runners | 8 pcs. 8' |
| Flooring - 3/4" | 6 pcs. 4x8 |
| Screw Floor Nails | 3 lb. 8d |
| Galv. Box Nails | 5 lb. 16d |

Step 1 Assemble Trusses



Building Tip: To aid in the assembly of the trusses, temporarily screw 2x4 blocks to the floor. There are short 2x4s, *that may have an angle on one end*, supplied in kit. This will insure that all the trusses are assembled the same.

1. Screw (2) two 2x4 blocks to the 12' wide end of the floor at the corner, *see below*.
2. Place two truss legs together. Position the notch in the 2x4s (called a bird's mouth) into the 2x4 blocks. **Important:** You must have 12'-0" between the bird's mouth. Affix more 2x4 blocks above the truss legs to hold the truss members in place.
3. Secure the tops together with a wood gusset. Apply wood glue between the 2x4 boards and the gusset. Nail the gusset to the 2x4s with 6d common nails. Use 14 nails per gusset.
4. Install a 2x4-90° collar tie between the 2x4 boards. Hold in place with 2x4 blocks. Install 12"x24" gussets to the ends of the collar tie. Glue and nail using 14 nails per gusset.
5. Turn this truss over and apply wood gussets to the opposite side.
6. Repeat 2 through 5 to assemble (6) six more trusses.

Do Not remove blocks from floor until completing **Step 2**.

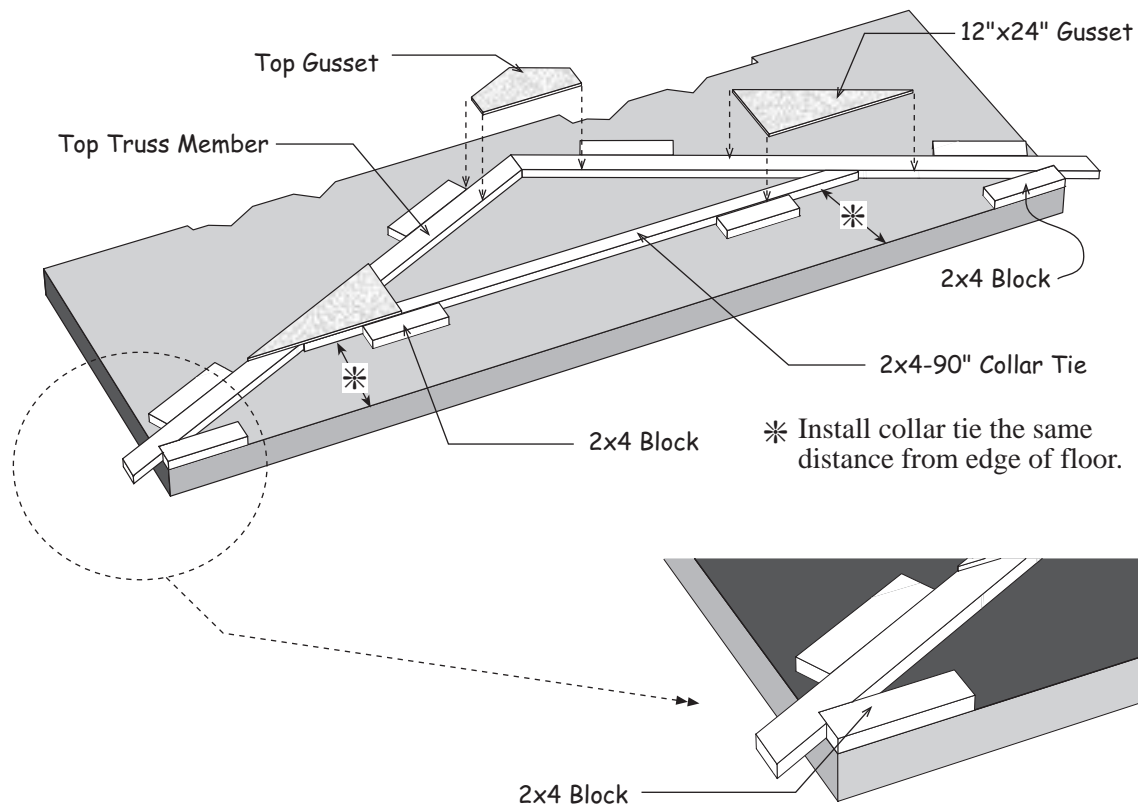

Step 2 Assemble Roof Gables

1. Butt (2) two 72" long 2x4s together and secure by nailing a 3-1/2" x 31-3/4" long plywood gusset across the top where they butt together. Use glue and 6d common nails.

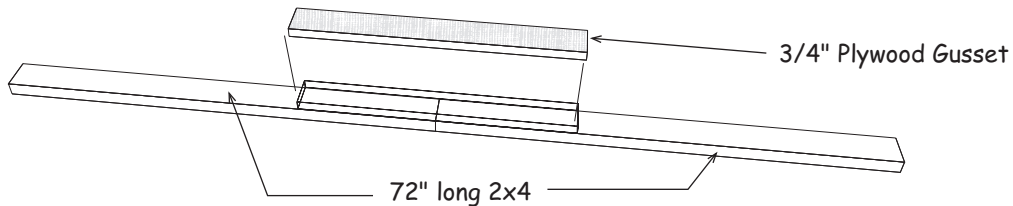

2. Place (2) two truss members in the jig. Secure the top together with a barbed metal plate.
3. Remove the 2x4 blocks at the corners of the floor and insert the gable plate assembled above into the bird's mouth. Make sure the 2x4 gable plate is straight. If necessary, tack 2x4 blocks to hold plate straight.

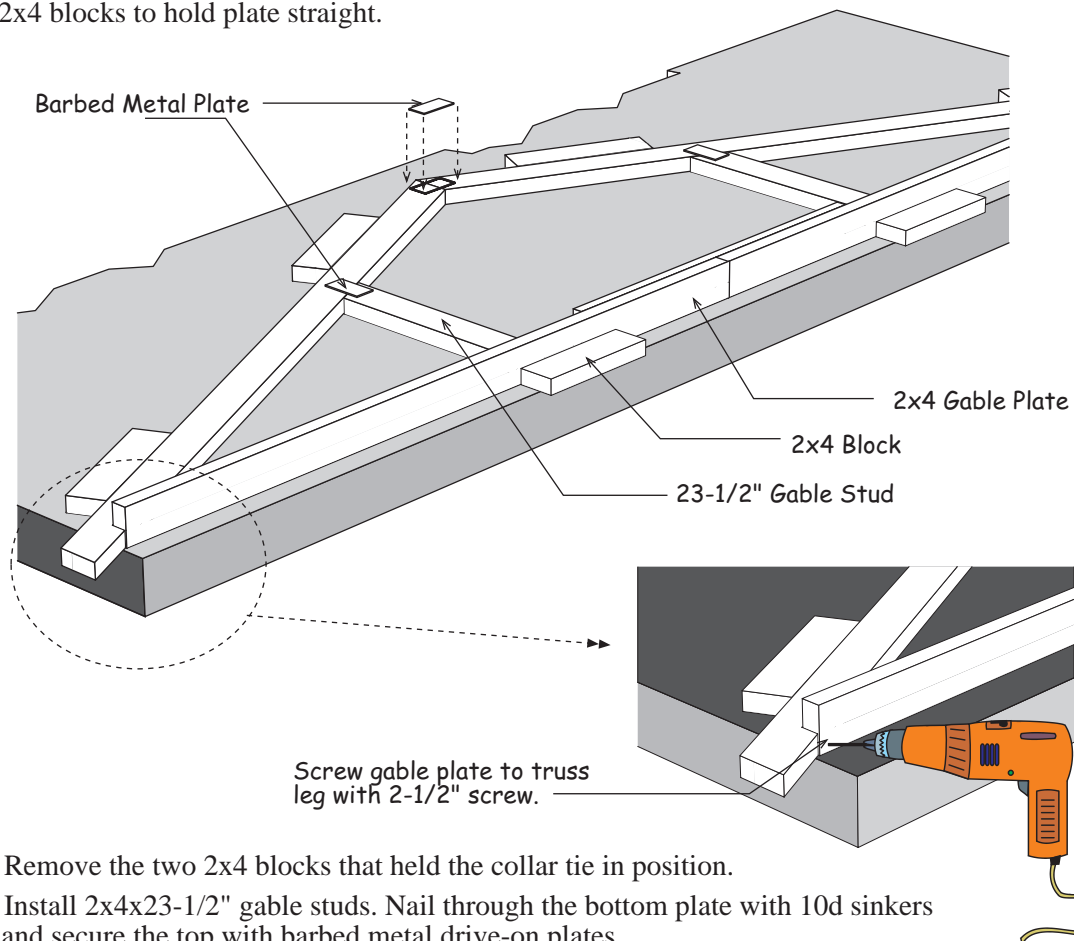

4. Remove the two 2x4 blocks that held the collar tie in position.
5. Install 2x4x23-1/2" gable studs. Nail through the bottom plate with 10d sinkers and secure the top with barbed metal drive-on plates.
7. Repeat to assemble another gable. Remove 2x4 blocks.

Step 3A Install Siding on Gables

1. Select one of the gable frames, Turn the gable over letting the bottom plate overhang the floor so the gable lays flat.
2. Cut a siding panel 39" in length. This will be used for the center of the gable. Cut the remaining siding panel in half for the ends of the gable.
3. Install the siding extending 1/4" below the bottom plate. Cut siding flush with the top of the gable. Install gable siding using 6d galv. nails across the top of the gable frame. Use 8d galv. nails along the bottom edge. Space nails 12" apart.

4. Install pre-cut siding on the ends of the gable. The siding should extend 1/2" below the 2x4 to receive the soffit when installed later.

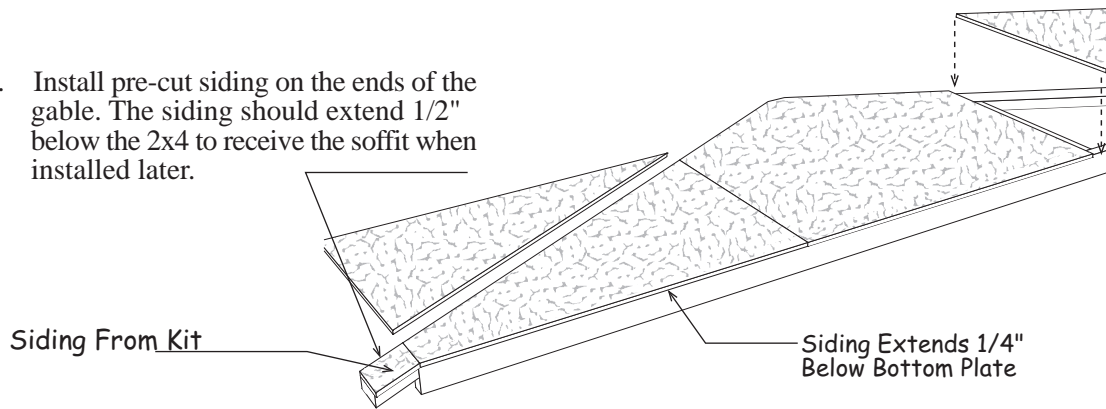

5. Repeat to side another gable.

Step 3B Install 2x4 gable Overhang

1. Install (2) two 86-1/4" long 2x4s on the gable, flush with the top of the gable siding. Secure with 10d sinkers.

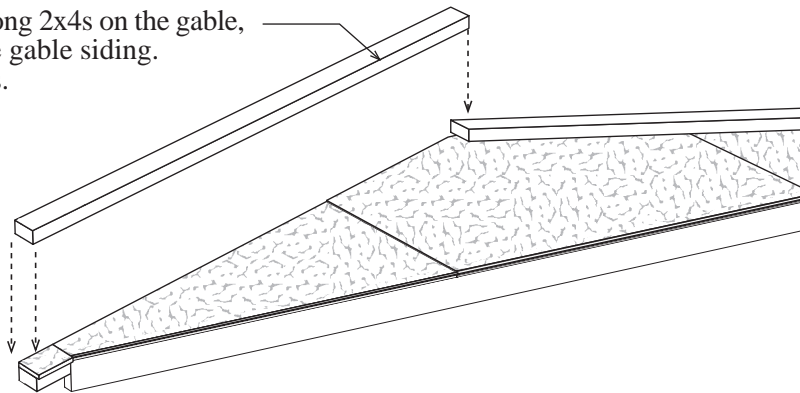

2. Repeat to install 2x4s on the another gable frame.

Step 4 Assemble 12' Back Wall

1. Position 2x4-68-1/2" boards together and indicate with 'X' marks, where the wall studs will be located. Mark the ends that will butt together with the letters 'A' and 'B'.

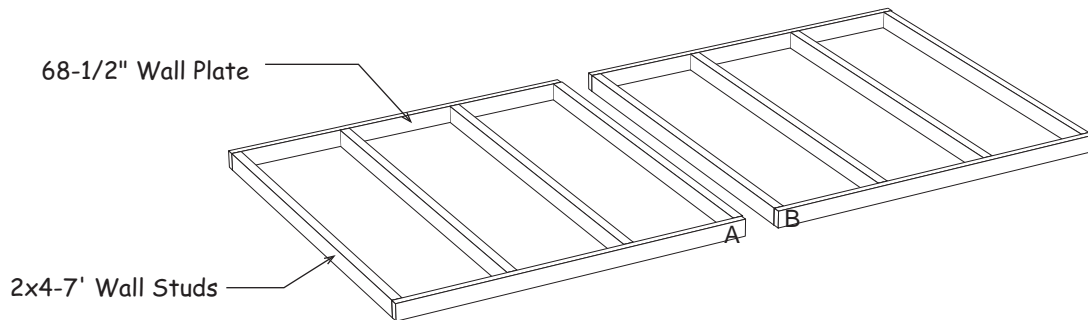
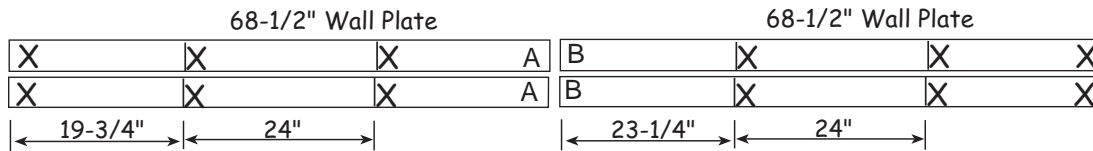

2. Install 7' wall studs between the top and bottom plates. Assemble wall frames with 10d sinkers, two (2) nails at each stud end. Nail both wall frames together.
3. Cut (12) twelve 4x8 OSB panels to a length of 87-1/4"
4. Square wall frame. *Measure diagonally (corner to corner). The measurements will be the same when the wall is square.*
5. Install the first siding panel extending 3-1/2" past the wall frame. The bottom will extend 3/4" below the bottom plate. Tip: Use 3/4" trim board as a gauge.
6. Install the other siding panels. Cut the last panel to extend 3-1/2" beyond the wall frame.

Install siding with 8d galv. nails.

The siding will be 1/2" below the top of the wall frame on all walls.

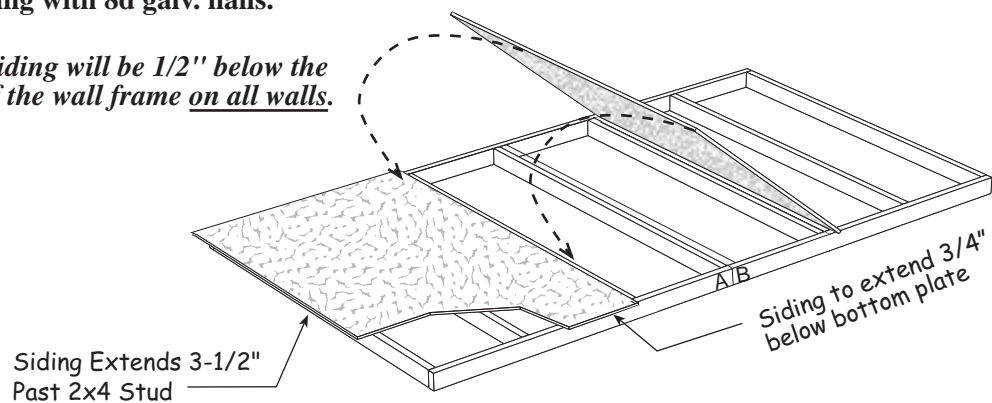

Step 5 Assemble 12' Long Sidewalls

1. Position 2x4-72" boards together and indicate with 'X' marks, where the wall studs will be located.

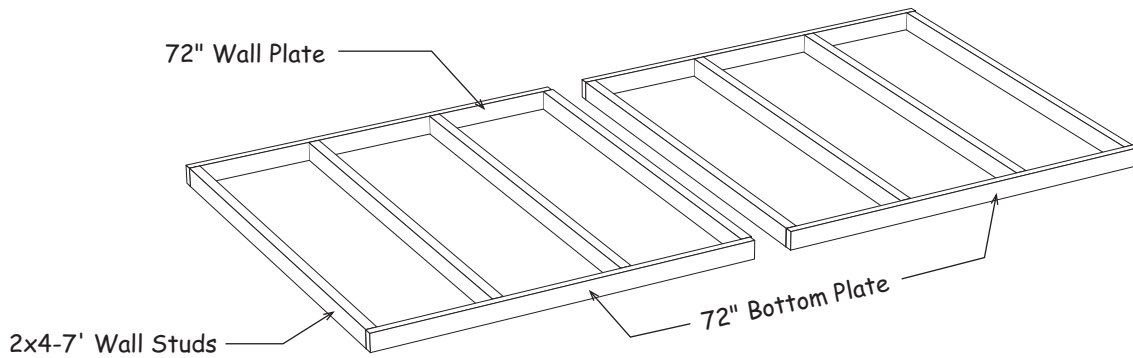
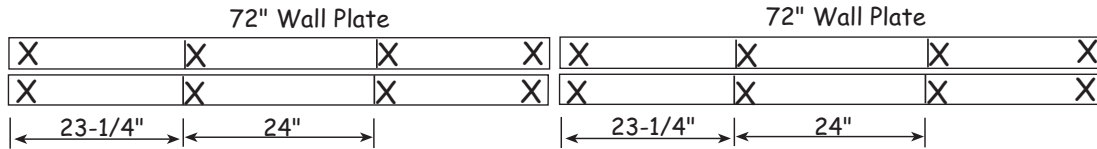

2. Install 7' wall studs between the top and bottom plates. Nail both wall frames together.



If you are installing the optional walk-in door see the instructions at the back of the book.

3. Square wall frame. Install the first siding panel flush with the end of the wall and extending 3/4" below the bottom plate.
4. Install (2) two more siding panels.

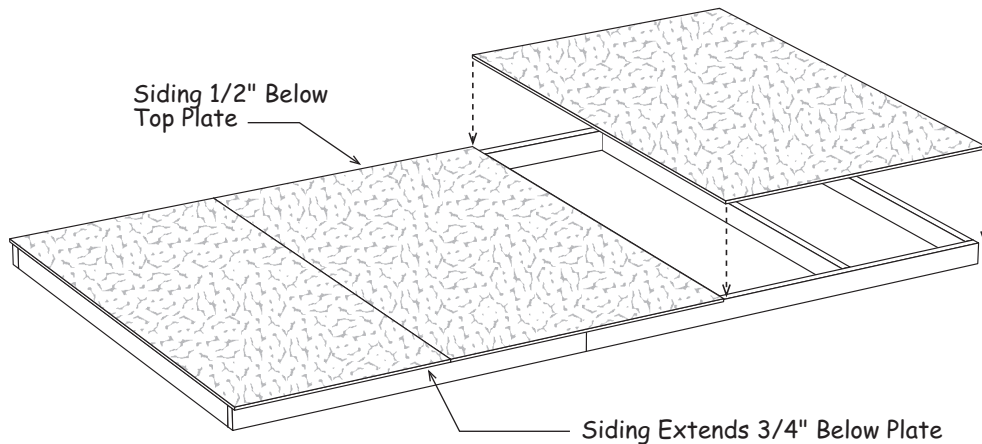

5. Repeat to assemble the another sidewall.

Step 6 Assemble 4' Long Sidewalls

1. Install (3) three 7' wall studs between (2) two 48" long 2x4s boards. Install the middle stud in the center of the wall frame.
2. Repeat to assemble another 4' wall section.

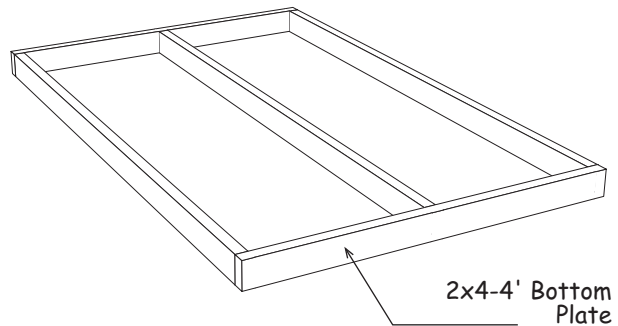

3. Square wall frame. Install a siding panel flush with the end of the wall and extending 3/4" below the bottom plate.

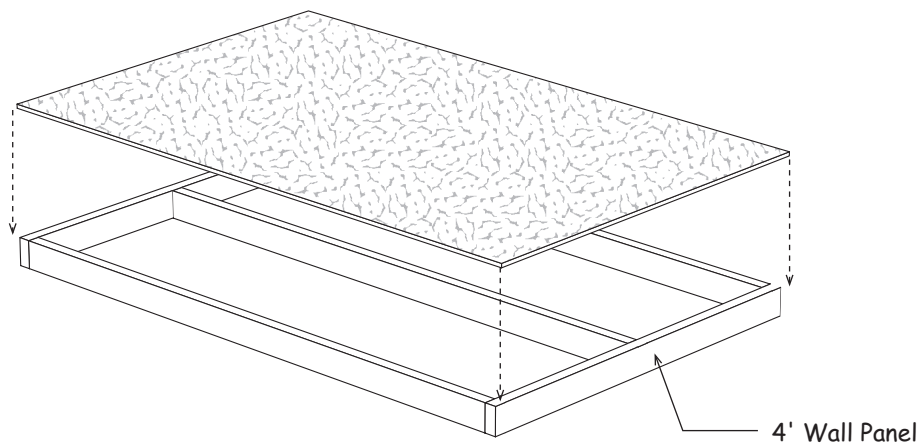

4. Repeat to apply siding to the other 4' wall frame.

Step 7 Assemble Door Walls

1. Locate a 7' wall stud with a 83-1/2" long 2x4 attached.
2. Assemble a wall frame using a 7' wall stud, the double stud and (2) two 19" long 2x4 wall plates. Use 10d sinkers.

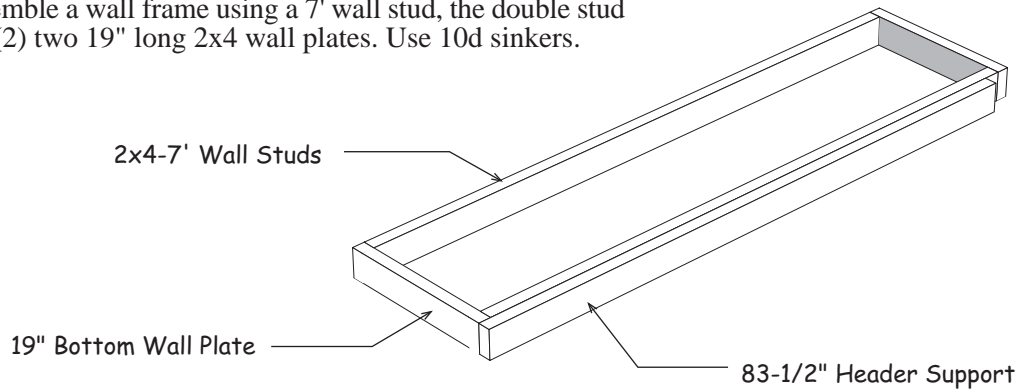

3. Repeat to assemble another wall frame.

4. Cut a panel in half and install a 24" wide siding panel flush with the 2x4 header support and extending 3/4" below the bottom plate.

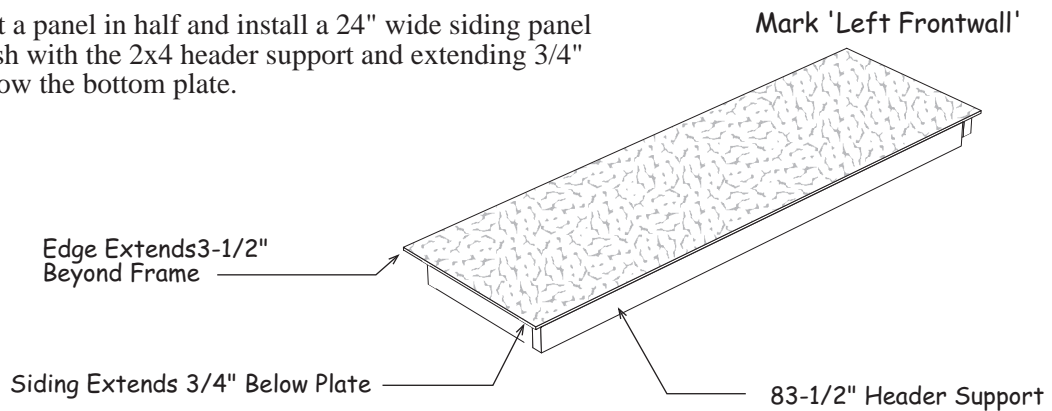

Mark 'Right Frontwall'

5. Install the remaining siding panel flush with the edge of the 2x4 header support.

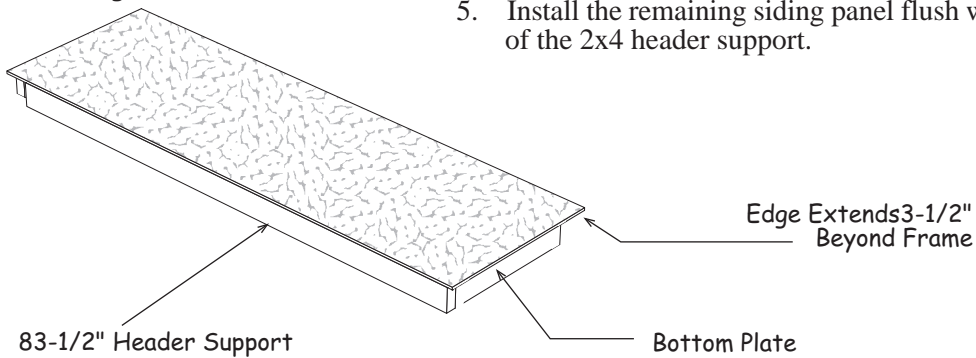

Step 8 Set Walls

1. Cut (2) two 2x4-10' boards to a length of 99".
2. Install (2) two 3" x 48" long OSB fillers (from our kit) on one of the 2x4 boards. Install fillers 1-1/2" from the end and flush with the bottom.
3. Nail the other 2x4 on top using 10d sinkers.

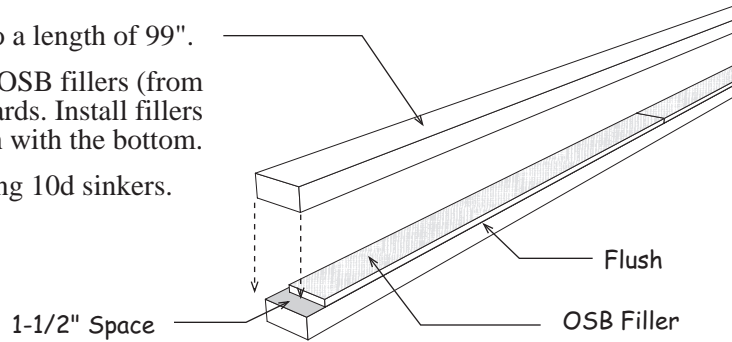

4. Set wall panels. Secure at corners with 10d sinkers (4 nails per corner). Secure to floor with 10 sinkers. Disassemble shipping pallet and use the 2x4s to brace the front wall and the sidewalls.
5. Install the door header, *built above*, between the front wall panels.

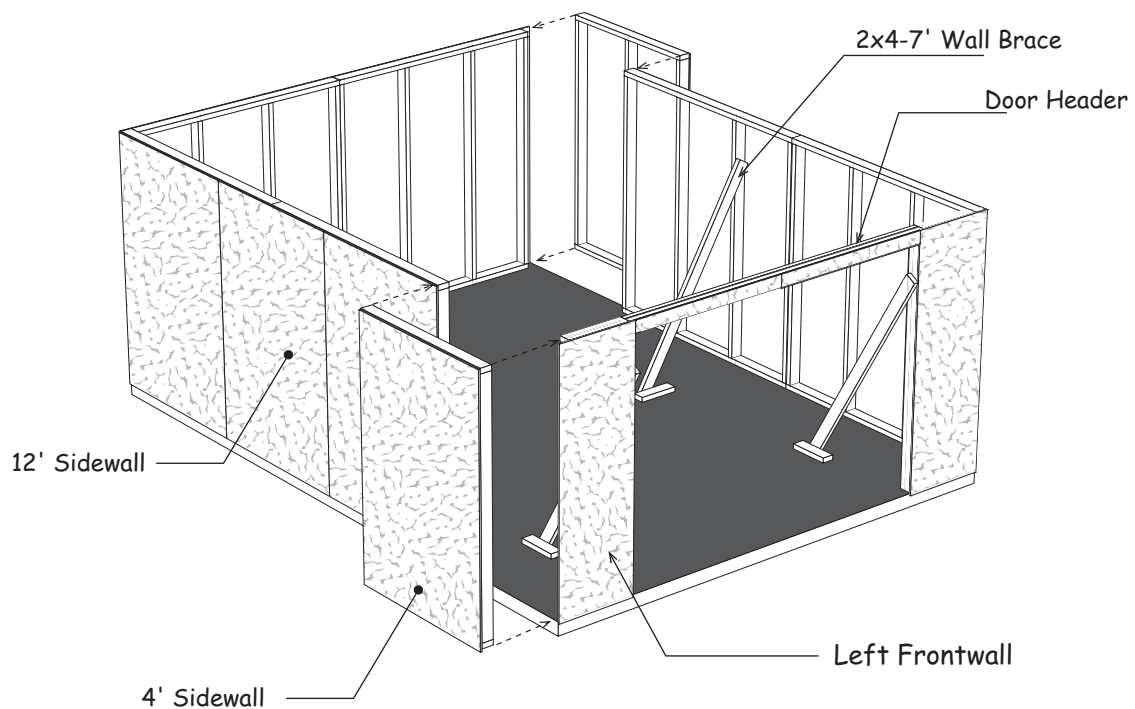

6. Install (2) two 3" x 48" long OSB fillers on the door header, flush with the bottom.

Step 9 Install Door Jamb

1. Install 48" long x 5-3/8" wide primed siding material on the top of the door opening.
2. Install 83" long x 5-3/8" wide primed siding material on the sides of the door opening.

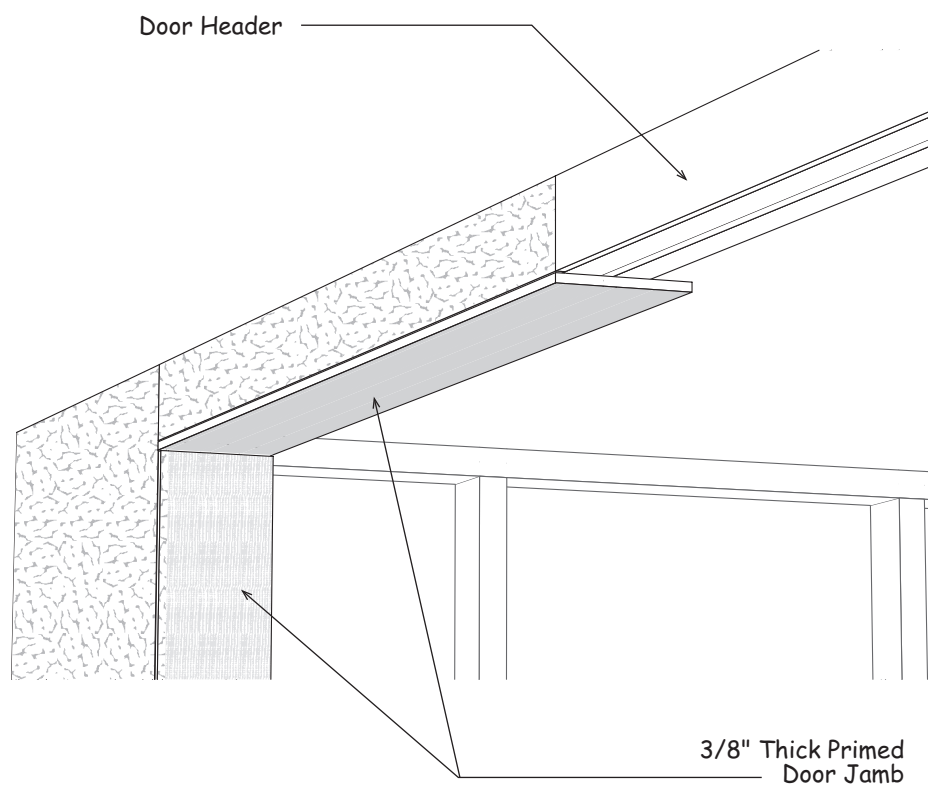

Step 10 Install Gables

1. Install a gable on the rear wall. Secure gable to wall by nailing through the gable plate with 10d sinkers.

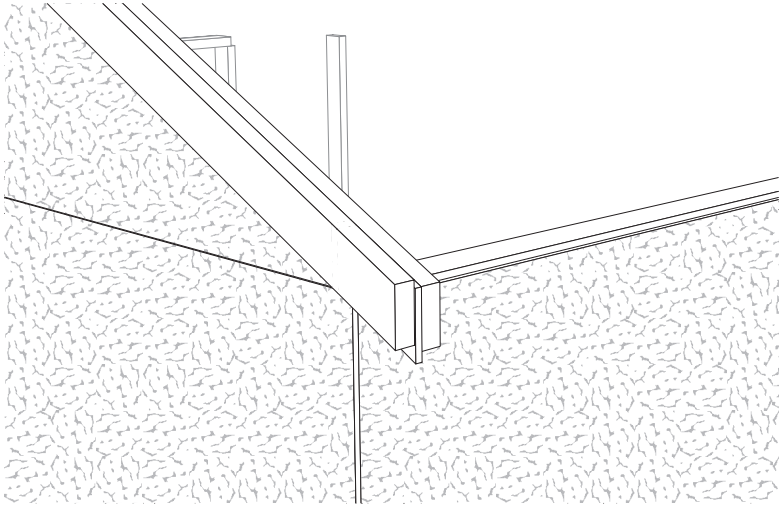

2. Repeat to install a gable on the front wall.

Step 11 Install 2x4 Tie Plates

Install 2x4-6' boards as tie plates on the both sidewalls between the rear and front gables. Use 10d sinkers.

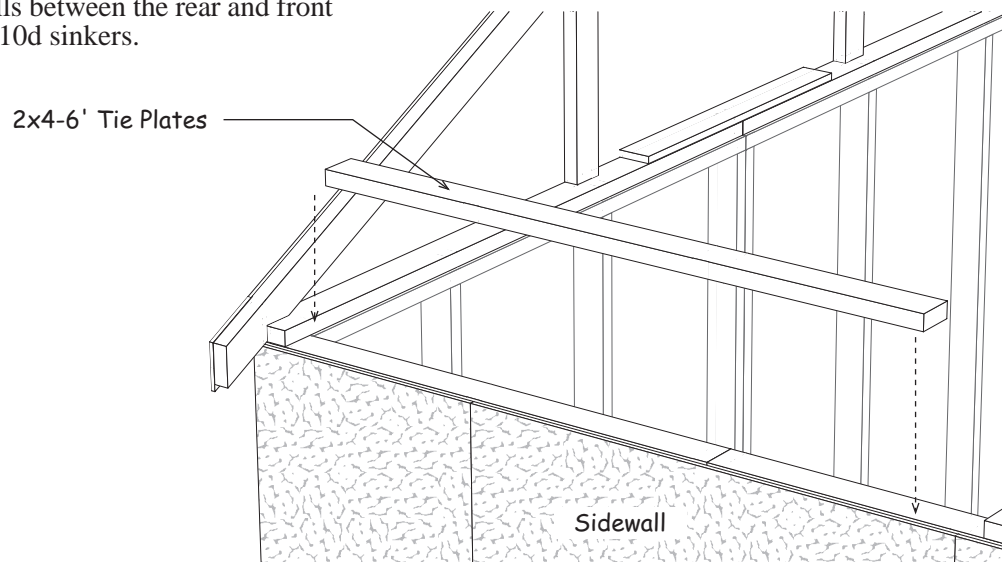

Step 12 Layout Roof Trusses

1. Layout the truss spacing from the rear of the building. Measure from the inside of the rear gable when marking the location of the first truss. **Important:** When marking the opposite wall, place the 'X' mark on the same side of the line so your trusses are parallel when they are installed.
2. Using 1-1/2" hanger nails, install metal hangers to the 2x4 tie plate. The opening should line up with the 'X' mark, the bottom of the opening, flush with the 2x4 tie plate. See **Detail 'D'**.

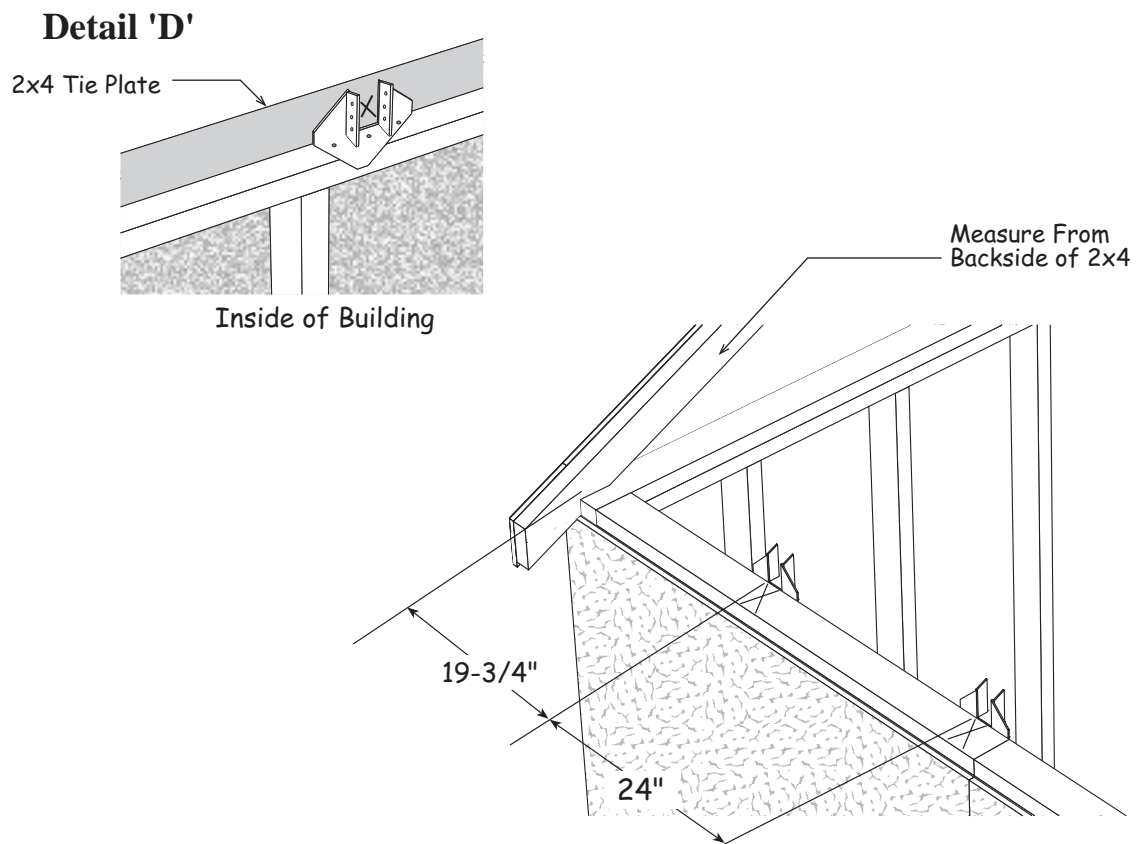

Step 13 Set Roof Trusses

Set roof trusses. Secure trusses to metal hangers with 1-1/2" hanger nails.

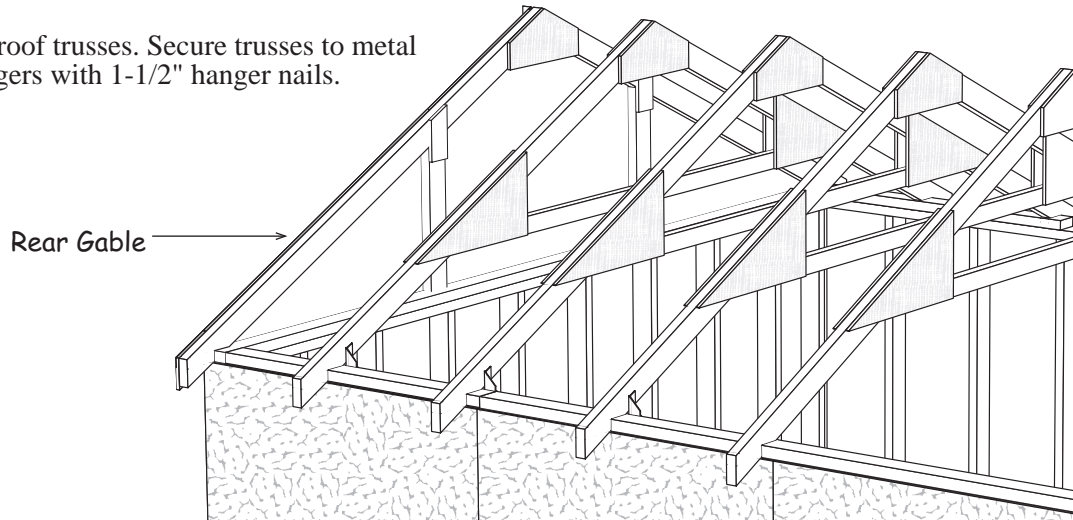

Step 14 Install Eave Soffit

Install 5" wide siding panels as soffit under the truss overhang. Use 8d galv. nails.

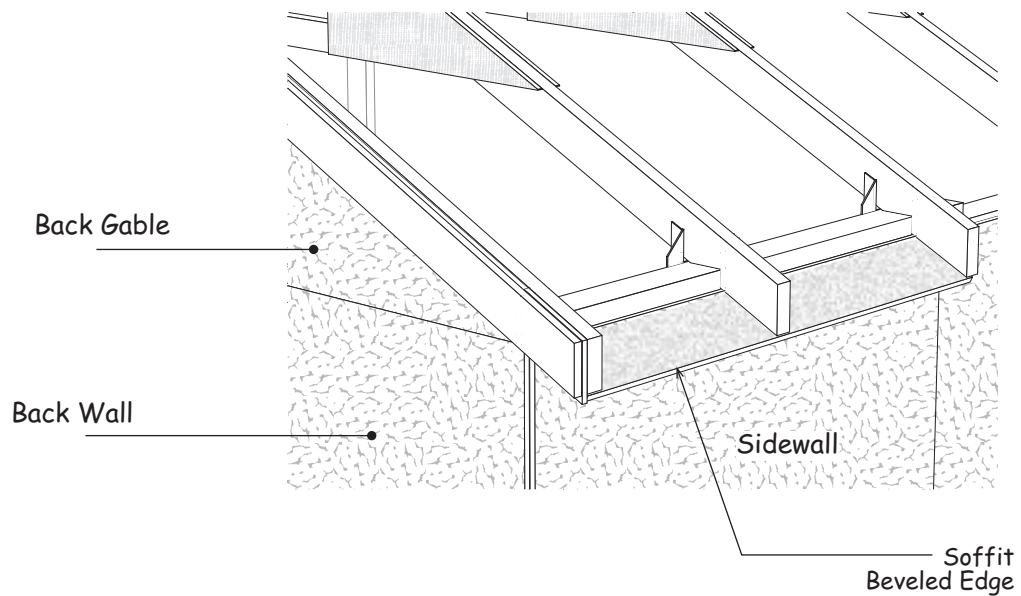

Step 15 Install 1x6 Fascia & Roof Sheathing

1. Cut (2) two 4x8 OSB panels into (2) two 4'x6' panels. Select the 2' wide pieces and cut them to a length of 37-1/2".
2. Cut (2) two 1x6-7' white pine fascia boards to a length of 72". Starting at the rear of the building, install the 1x6 fascia boards and 4x6 roof sheathing on each side, flush with the face of the 2x4s on the back gable.

Install the fascia so the bottom edge of the roof sheathing will rest on the 1x6. Use a straight edge to align the 1x6 boards with the top of the trusses. Install fascia with 8d galv. nails.

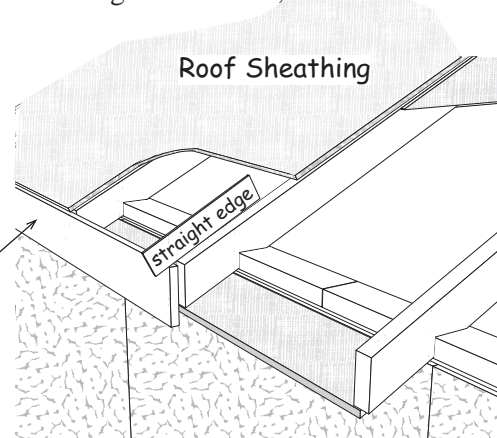

3. Cut (2) two 1x6-7' fascia boards to 72" and install on each side.
4. Cut (2) two 4x8 panels to a width of 37-1/2". Cut a 4x8 panel in half creating (2) two pieces 48" x 48".
5. Make sure the trusses are plumb and the roof sheathing meets the center of the truss. Install the bottom row first. Use 7d sinkers spaced 12" apart. The top row of roof sheathing will be about 1" below the ridge to allow for ventilation if ridge vent is used.

Important: Make sure the front gable is plumb and the roof sheathing extends 8-1/2" past the siding along the face of the gable.

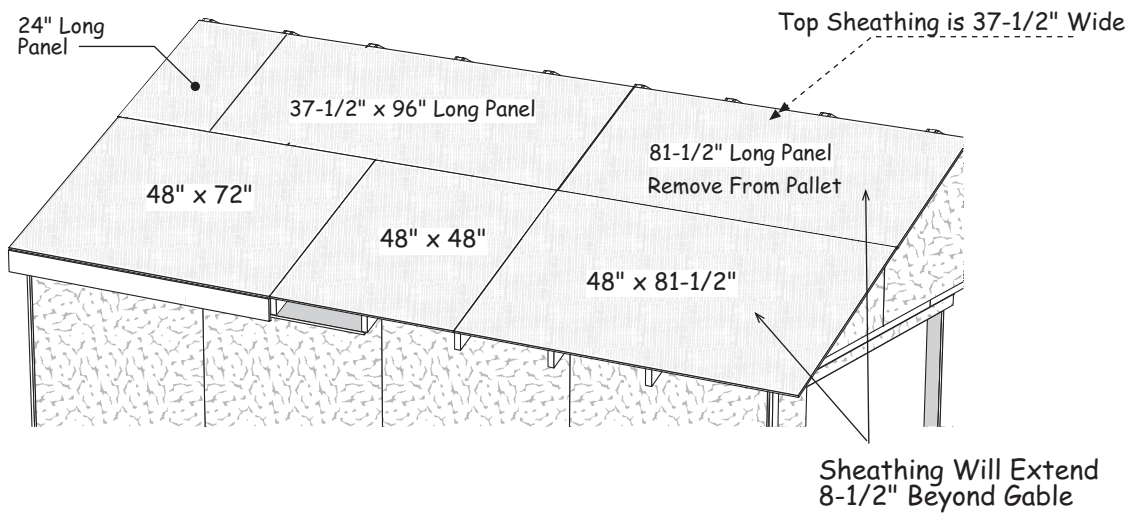

Step 16 Install Front Soffit

1. Install 86" long 2x4s under the front edge of the roof sheathing. Hold the 2x4s against the roof sheathing and screw through the sheathing into the 2x4 boards. Use 1-5/8" long screws.
2. Install 8-1/2" wide siding under the gable overhang as the soffit. Use 6d galv. nails.

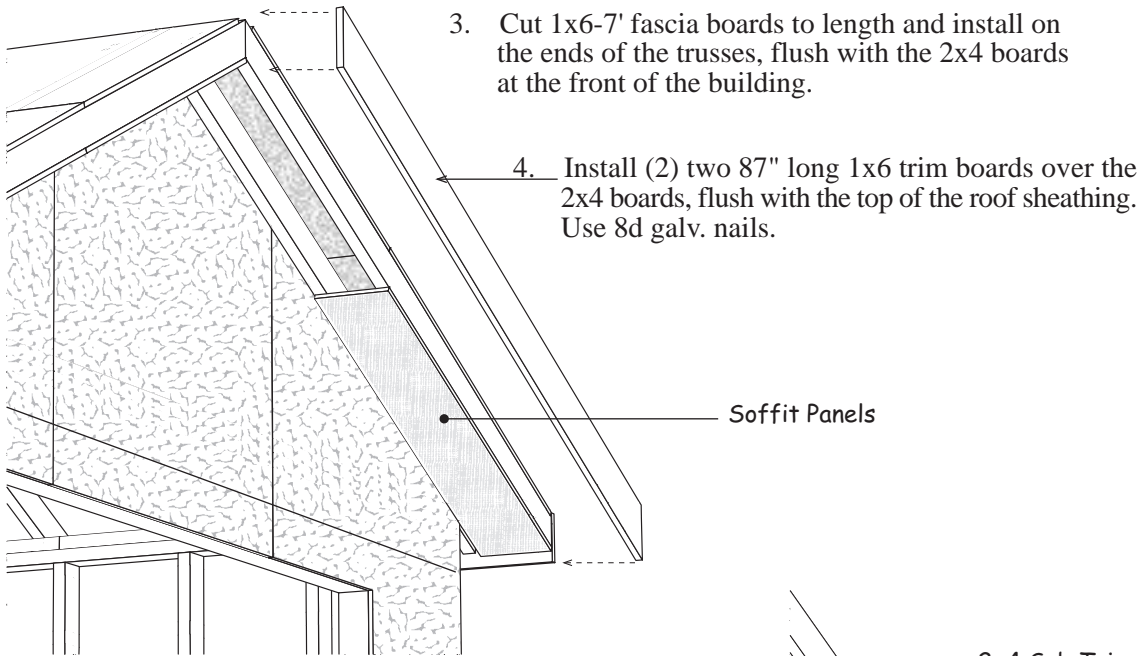

5. Install 1x6 trim on the rear gable, flush with the top of the roof sheathing. Use 8d galv. nails.
The 1x6 gable trim will extend below the 2x4 sub-trim creating a slot for the vinyl siding.

Install vinyl outside corners under the 1x6 gable trim.

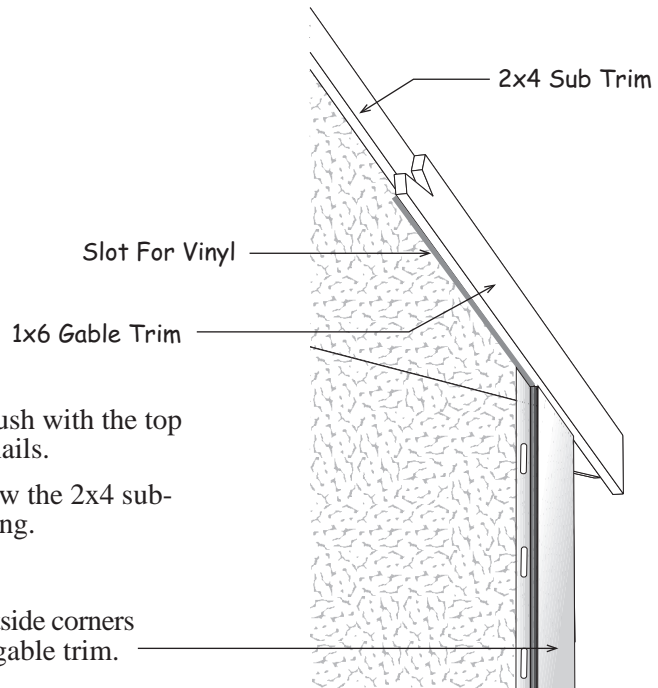

Step 17 Install 2x4 Around Door Jamb

1. Install a 2x4 - 7' on the inside of the door opening to support the door track.
2. Install 51-1/2" long 2x4s across the top of the door jamb.

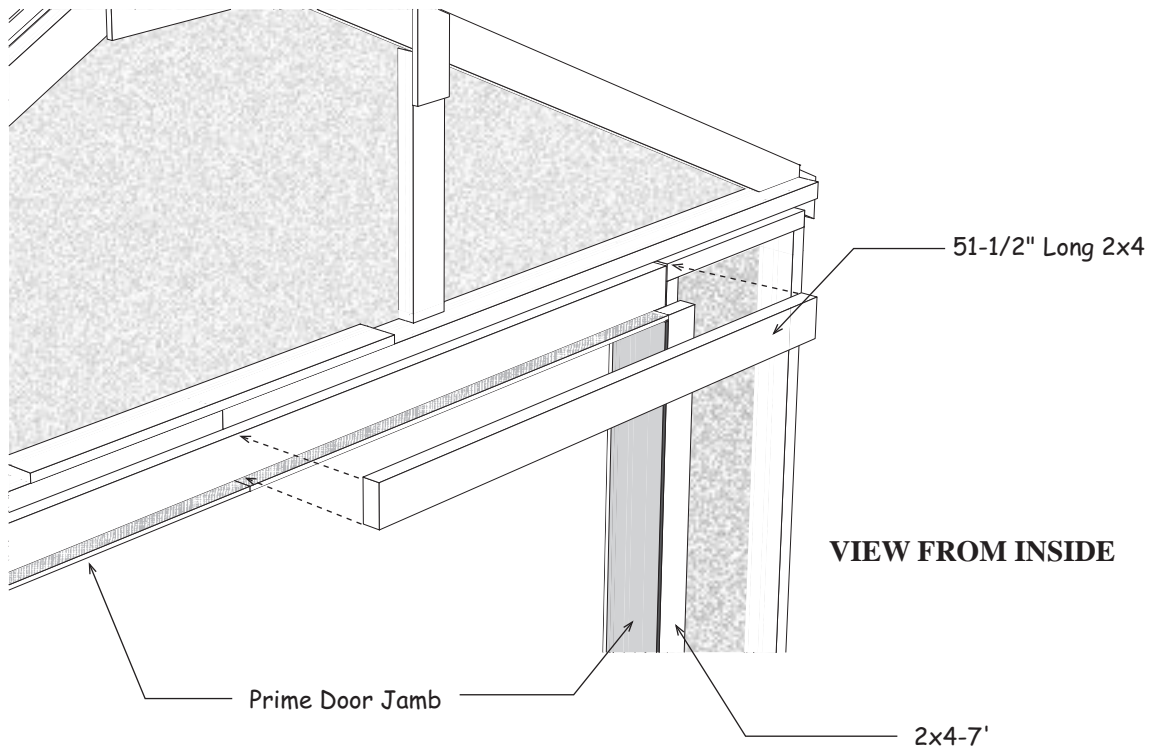

Install Optional Door Sill

If you ordered the optional floor, install the galvanized door sill. Secure sill with pan head screws.

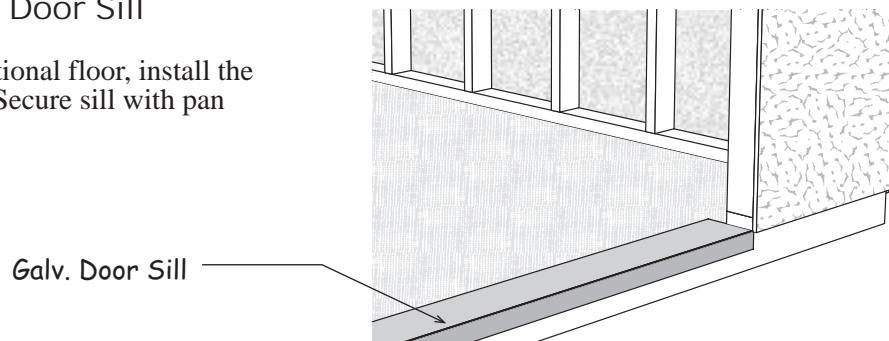

Step 18 Install Door Trim

1. Install 1x4-84" trim boards along each side of the door opening.
2. Install (2) two 51-1/4" long trim boards across the top of the door opening.

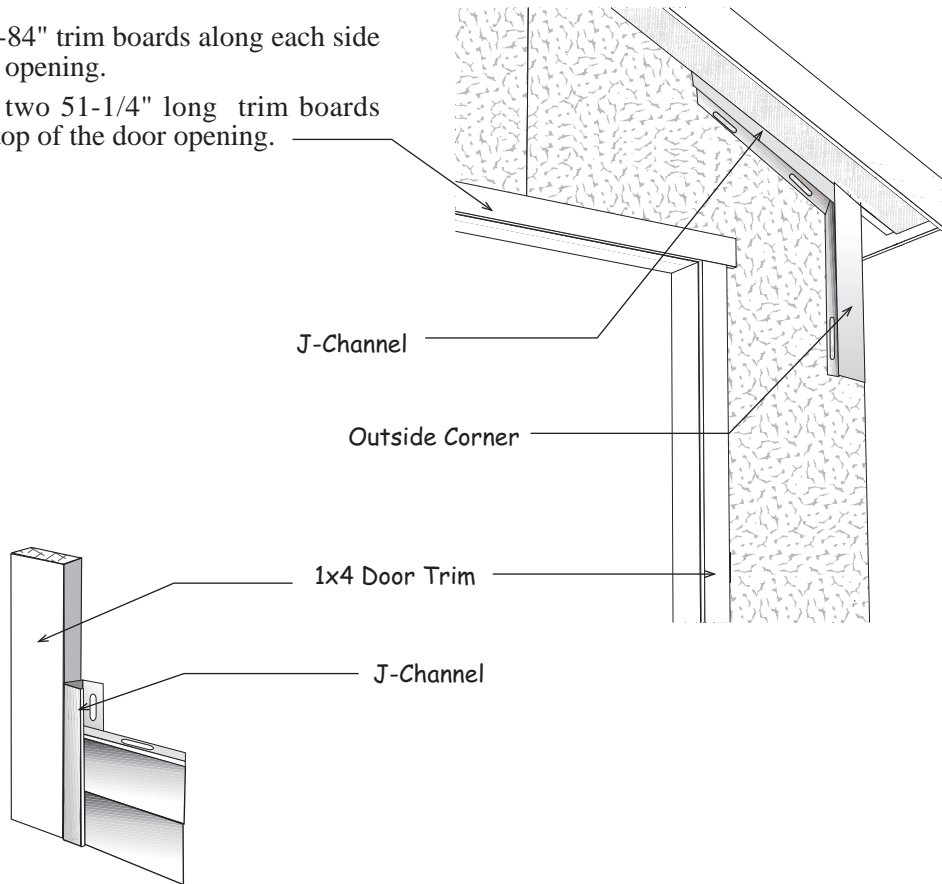

Vinyl Siding Overview

Install the siding according to the manufacturer's instructions.

Starter Strip is installed along the bottom of the building.

Center the nail in the nailing slots. **DO NOT** nail the siding tight. The panels should float on the nails to provide for expansion and contraction. Nail into wall studs wherever possible. If it is necessary to nail between the studs, cutoff the tips of nails that protrude through the siding.

When installed, the siding panels should have 1/4" free space at each end of the siding panel. This will allow the panel to expand with changes in temperature.

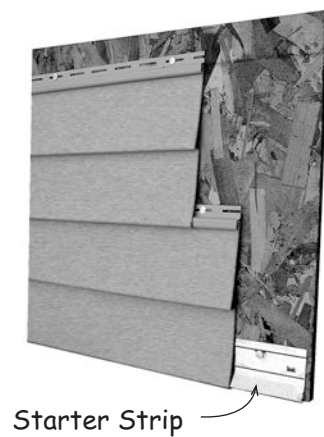

Step 19 Install Roofing — Not Supplied in Kit

1. Install metal roof edging perimeter of the roof area. If you are not installing shingles at this time, you can purchase felt paper to protect the roof sheathing. Install the felt paper before you install the metal roof edge.

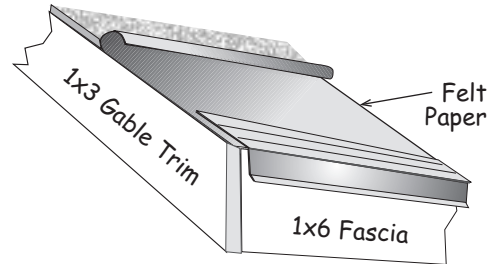

2. Install shingles according to the instructions on the wrapper. If you need more detailed instructions on installing shingles, there are good publications at book stores or newsstands.

Building Tip: Install a ridge vent in lieu of shingle caps. Ridge vent provides ideal ventilation, preventing heat or moisture from damaging your building or its contents.

Optional ridge vent provides ideal ventilation.

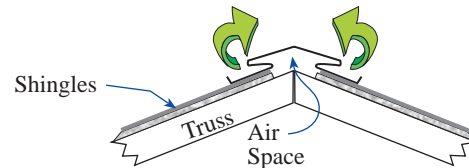

Optional Door Opening

1. Cut (2) two header supports from pre-cut wall studs.
2. Cut (2) two 37-1/2" boards from a 2x4-7'. Cut a filler from leftover OSB. Install the filler between the 2x4 boards to make a door header.
3. Install door header over header supports.

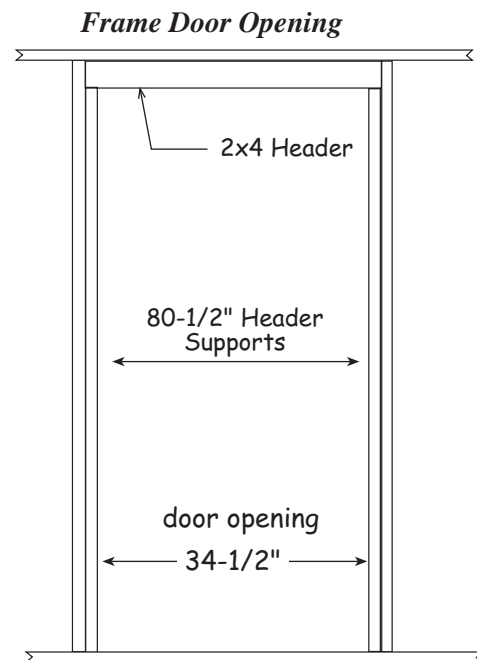

Material Packaged In Lumber Kit

| | | | | | | | |
|----|----------------------|-------|-------------------|----|-----------|----------------------|---------------------|
| 7 | Collar Ties | 2x4 | 90" | 3 | 1 lb. box | 10d | Sinkers |
| 24 | Truss Rafters | 2x4 | 86-1/4" | 3 | 1 lb. box | 8d | Galv. |
| 37 | Wall Studs | 2x4 | 84" | 2 | 1 lb. box | 7d | Sinkers |
| 2 | Double Studs | 2x4 | 84" | 1 | 1 lb. box | 6d | Galv. |
| 18 | Wall Plates | 2x4 | 72" | 3 | 1 lb. box | 6d | Common |
| 4 | Wall Plates | 2x4 | 68-1/2" | 1 | 1 lb. box | 1-1/2" | Hanger Nails |
| 2 | Door Jamb | 2x4 | 51-1/2" | 6 | ea. | 1x4 | Metal Plates |
| 4 | Wall Plates | 2x4 | 48" | 14 | ea. | 2x4 | Metal Truss Hangers |
| 4 | Wall Plates | 2x4 | 19" | 1 | bag | | Wood Screws |
| 4 | Gable Studs | 2x4 | 23-1/2" | 2 | ea. | | Bottle Glue |
| 8 | Primed Soffit Boards | 3/8" | 5" x 48" | 8 | pcs. | 2x4 Truss Jig Blocks | 10" |
| 2 | Primed Soffit Boards | 3/8" | 5" x 24" | 4 | pcs. | 1x6 Gable Trim | 87" |
| 4 | Primed Soffit Boards | 3/8" | 8-1/2" x 48" | 6 | pcs. | 1x6 Fascia Trim | 84" |
| 2 | Primed Door Jamb | 3/8" | 5-3/8" x 48" | 2 | pcs. | 1x4 Door Trim-sides | 84" |
| 2 | Primed Door Jamb | 3/8" | 5-3/8" x 83" | 2 | pcs. | 1x4 Door Trim-top | 51-1/4" |
| 2 | Plywood Gusset | 3/4" | 3.5" x 32" | 14 | pcs. | 7/16" Truss Gussets | 8" x 20" |
| 2 | Roof Sheathing | 7/16" | 37-1/2" x 81-1/2" | 28 | pcs. | 7/16" Truss Gussets | 12" x 24" |

Material Supplied by Local Supplier

| Size | Material List |
|---------|-------------------------|
| 12x16 | |
| 14 pcs. | OSB Siding 4x8 7/16" |
| 7 pcs. | OSB Sheathing 4x8 7/16" |
| 2 pcs. | 2x4 - 10' Door Header |

| Roof Covering - not supplied in kit | |
|-------------------------------------|----------------------|
| 10 bdl. | Roof Shingles |
| 8 pcs. | Roof 'drip' Edge 10' |

