

INSTALLATION, OPERATING AND SERVICE INSTRUCTIONS FOR

ES2™

ENHANCED SERIES 2 Gas - Fired Boiler



As an ENERGY STAR® Partner, Burnham by U.S. Boiler Company has determined that this boiler meets the ENERGY STAR® guidelines for energy efficiency established by the United States Environmental Protection Agency (EPA).

For service or repairs to boiler, call your heating contractor. When seeking information on boiler, provide Boiler Model Number and Serial Number as shown on Rating Label.

Boiler Model Number ES2	Boiler Serial Number	Installation Date
Heating Contractor		Phone Number
Address		





WARNINGS FOR THE HOMEOWNER

FOLLOW ALL INSTRUCTIONS and warnings printed in this manual and posted on the boiler.

INSPECT THE BOILER ANNUALLY. To keep your boiler safe and efficient, have a service technician follow the Service checklist near the end of this manual.

IF YOU ARE NOT QUALIFIED to install or service boilers, do not install or service this one.

THE BOILER MAY LEAK WATER at the end of its useful life. Be sure to protect walls, carpets, and valuables from water that could leak from the boiler.

PROTECT YOUR HOME IN FREEZING WEATHER. A power outage, safety lockout, or component failure will prevent your boiler from lighting. In winter, your pipes may freeze and cause extensive property damage. If you must leave your home unattended for an extended time when

outdoor temperatures are below 32°F, first turn off your home's main water supply and drain the water from all pipes.

DO NOT BLOCK AIR FLOW into or around the boiler. Insufficient air may cause the boiler to produce carbon monoxide or start a fire.

KEEP FLAMMABLE LIQUIDS AWAY from the boiler, including paint, solvents, and gasoline. The boiler may ignite the vapors from the liquids causing explosion or fire.

KEEP CHILDREN AND PETS away from hot surfaces of the boiler, boiler piping, and vent pipe.

CARBON MONOXIDE (CO) is an odorless, deadly gas that may be introduced into your home by any malfunctioning fuel-burning product or vent system failure. Consider installing CO alarms near bedrooms in all levels of the building to warn you and your family of potential CO exposure.



WARNINGS FOR THE INSTALLER

READ THIS ENTIRE MANUAL before attempting installation, start-up, or service. Improper installation, adjustment, alteration, service, or maintenance may cause serious property damage, personal injury, or death.

DO NOT DISCONNECT PIPE FITTINGS on the boiler or in the heating system without first verifying that the system is cool and free of pressure and that your clothing will protect you from a release of hot water or steam. Do not rely solely on the boiler's temperature and pressure gage when making this judgment.

USE PROPER PERSONAL PROTECTION EQUIPMENT when servicing or working near the boiler. Materials of construction, flue products, and fuel contain alumina, silica, heavy metals, carbon monoxide, nitrogen oxides, and/or other toxic or harmful substances that can be hazardous to health and life and that are known to the State of California to cause cancer, birth defects, and other reproductive harm.

INSTALL ALL GUARDS, cover plates, and enclosures before operating the boiler.

SIZE THE BOILER PROPERLY relative to the design heat load or, if using domestic hot water priority, the peak hot water load, whichever is larger. A grossly oversized boiler will cycle excessively and this will lead to premature failure of the boiler and its components. Our warranty does not apply to damage from excessive cycling.

ADHERE TO ALL LOCAL CODE REQUIREMENTS. Contact your local code inspector prior to installation. In the absence of a local code, adhere to the *National Fuel Gas Code ANSI Z223.1/NFPA 54* or *CAN/CSA B149.1, Natural Gas and Propane Installation Code*.

ALL WIRING must comply with the *National Electrical Code ANSI/NFPA 70* (in the USA) or the *Canadian Electrical Code CSA C22.1* (in Canada) and any local regulations.

Congratulations on your purchase of a new Burnham® boiler—designed and constructed to provide you with years of reliable service.

- *ENERGY STAR™ efficiency* – friendly on the environment and your wallet.
- *Cast iron heat exchanger* – for reliability and durability, nothing beats a cast iron heat exchanger. Ours is made proudly by our foundry in Zanesville, Ohio.
- *IQ Control™* – the most advanced and easiest to use control available.
- *System-friendly* – built-in protection from condensation and thermal shock.

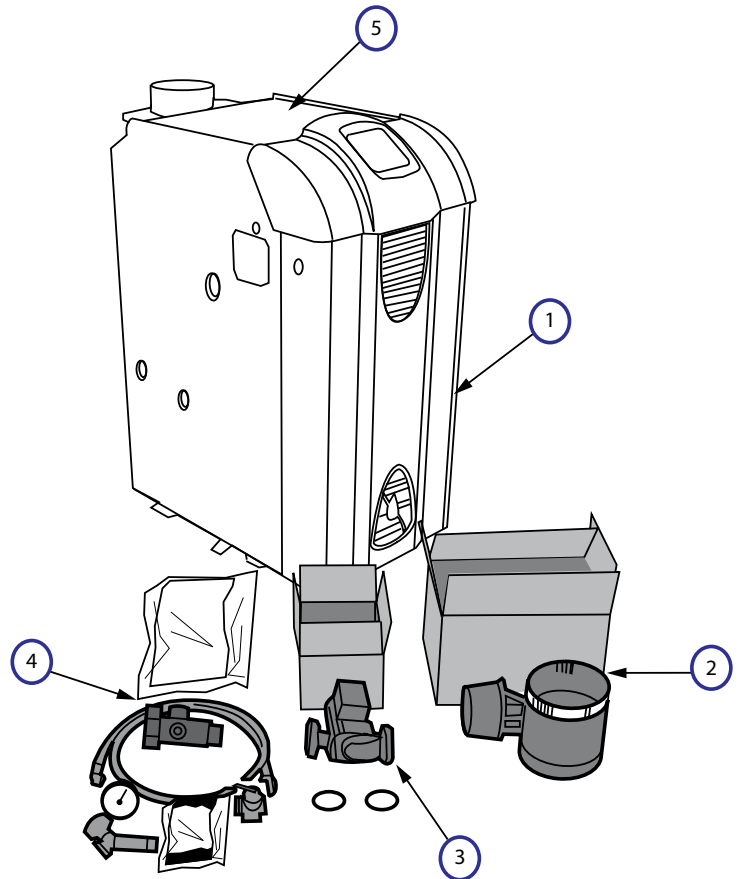

What's in the crate?

1. ES2™ Boiler
2. Vent Damper w/ Carton
 - 4" Damper — ES23 (102284-01)
 - 5" Damper — ES24 (102284-02)
 - 6" Damper — ES25 & ES26 (102284-03)
 - 7" Damper — ES27 & ES28 (102284-04)
 - 8" Damper — ES29 (102284-05)
3. Circulator & Gasket Kit
 - Taco 007-2 (8056170)
 - Grundfos UP-15 (102805-01)
 - B & G NRF-22 (8056174)
4. Miscellaneous Parts Bag (102627-01)
 - Temperature/Pressure Gage; 1/4" NPT (100282-01)
 - Circulator Mounting Hardware Kit, 1-1/4" NPT (6056007)
 - Circulator Wiring Harness (6130701)
 - Drain Valve; 3/4" NPT (806603012)
 - Pressure Relief Valve; 30 psi (81660363)
 - Water Manifold for Pressure Relief/Temp. Gage (80607001)
5. Instruction Envelope (102625-01)
 - Instruction & Operation Manual (102538-01)
 - Hydronics Institute Instructions (81460061)
 - Boiler Warranty Sheet (102198-01)
 - Equipment List (102620-01)



SPECIFICATIONS

Ratings

	ES2 Series			
Boiler Model	Input (MBH)	DOE Heating Capacity (MBH)	Net I=B=R Rating (MBH)	AFUE (%)
ES23	70	59	51	85
ES24	105	89	77	85
ES25	140	119	103	85
ES26	175	149	130	85
ES27	210	178	155	85
ES28	245	208	181	85
ES29	280	238	207	85

Electrical Requirements: 120VAC, 60 Hz, 1-ph, 15A

Dimensions and Connections

Boiler Model	Depth	Width	Height	Supply NPT (inch)	Return NPT (inch)	Vent (inch)	Gas NPT (inch)	Relief Valve NPT (inch)	Drain NPT (inch)
ES23	33	12 ³ / ₄	41	1 ¹ / ₄	1 ¹ / ₄	4	1/2	3/4	3/4
ES24	33	15 ¹ / ₂	41	1 ¹ / ₄	1 ¹ / ₄	5	1/2	3/4	3/4
ES25	33	18 ¹ / ₂	41	1 ¹ / ₄	1 ¹ / ₄	6	1/2	3/4	3/4
ES26	33	21 ¹ / ₂	41	1 ¹ / ₄	1 ¹ / ₄	6	1/2	3/4	3/4
ES27	33	24 ³ / ₄	41	1 ¹ / ₄	1 ¹ / ₄	7	3/4	3/4	3/4
ES28	33	27 ³ / ₄	41	1 ¹ / ₄	1 ¹ / ₄	7	3/4	3/4	3/4
ES29	33	30 ³ / ₄	41	1 ¹ / ₄	1 ¹ / ₄	8	3/4	3/4	3/4

Water Temperatures and Flows

Boiler Model	Allowable Supply Water Temperature (°F)	Minimum Return Water Temperature (°F)	Minimum Flow (GPM)	Waterside Pressure Drop at 20°F ΔT (Ft. of Head)
ES23	130-220	110	None	<1
ES24	130-220	110	None	<1
ES25	130-220	110	None	<1
ES26	130-220	110	None	<1
ES27	130-220	110	None	<1
ES28	130-220	110	None	<1
ES29	130-220	110	None	<1

Weights and Volume

Boiler Model	Shipping Weight (lbs)	Empty Weight (lbs)	Water Content (gal)
ES23	254	180	2
ES24	304	231	3
ES25	357	284	4
ES26	405	332	5
ES27	462	382	5
ES28	518	438	6
ES29	564	484	7

SPECIFICATIONS (continued)

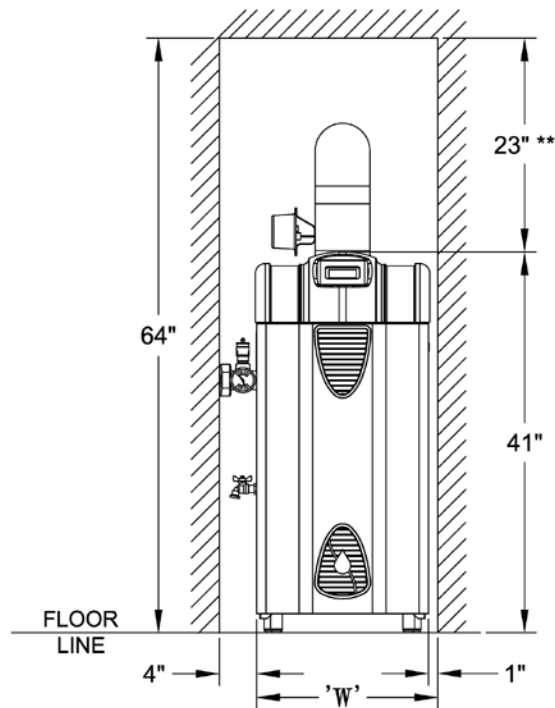
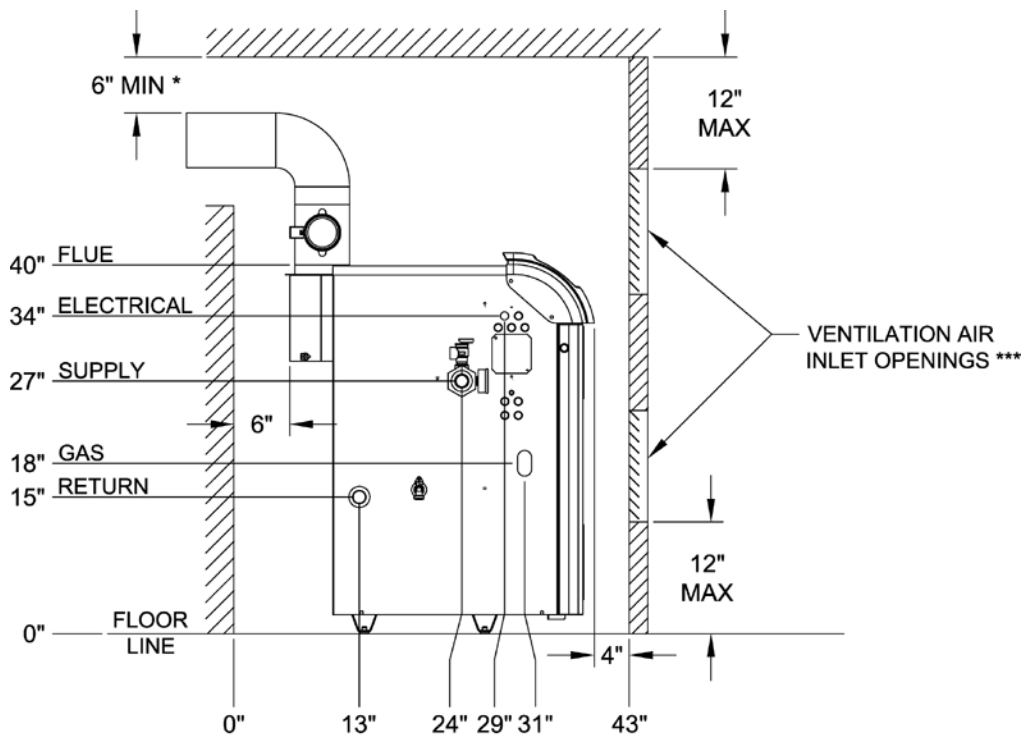

MODEL	'W'
ES23	14"
ES24	16"
ES25	19"
ES26	22"
ES27	25"
ES28	28"
ES29	31"

NOTES:

* MINIMAL RADIAL DISTANCE AROUND VENT PIPE AND BREECHING.

** ADD HEIGHT REQUIRED TO MAINTAIN 6" CLEARANCE FROM ALL BREECHING COMPONENTS.

*** AREA OF EACH OPENING, 1 SQ. INCH FOR EACH 1000 BTUH INPUT - WITH MINIMUM OF 100 SQ. INCHES. HEIGHT OF OPENING SHOULD BE HALF THE WIDTH.

Figure S-1: Minimum Clearances to Combustibles and Closet Dimensions

BOILER QUICK-START

Installation:

1. Unpack the crate	7
2. Position the boiler	7
3. Provide combustion air	8
4. Connect venting.....	8
5. Connect gas piping.....	10
6. Connect boiler water piping	10
7. Connect electrical wiring.....	12
8. Program the controls	13
9. Check for gas and water leaks	15
10. Perform startup checks and adjustments	16

Annual Maintenance Checklist.....	17
------------------------------------------	-----------

Troubleshooting.....	18
-----------------------------	-----------

Repair Parts List.....	21
-------------------------------	-----------

Internal Wiring.....	27
-----------------------------	-----------

Appendices:

A – Combustion Air.....	32
B – Venting	33
C – Gas Piping	36
D – System Piping.....	37
E – Filling the System and Checking for Leaks	43
F – Adjusting Gas Input Rate	44
G – Checking Draft and Combustion.....	46
H – IQ Control System.....	47

Warranty	Back Cover
-----------------------	-------------------

1. UNPACK THE CRATE



THE BOILER IS TOP-HEAVY. Do not allow it to tip over.

1. Remove the sleeve.
2. Remove the contents from the skid, except the boiler.
3. Remove the four (4) hex-drive lag screws holding the boiler to the skid (Figure 1-a).



4. Tip the boiler and shimmy it off the skid.

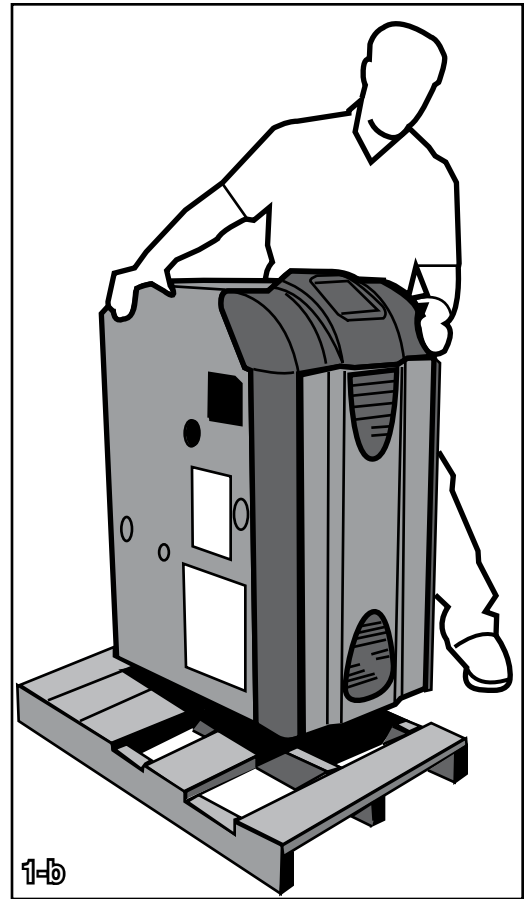

2. POSITION THE BOILER



WARNINGS

OBSERVE MINIMUM CLEARANCES to combustibles walls and ceilings to avoid potential fire hazard.

DO NOT INSTALL ON CARPET. This may cause a fire.

INSTALLING THE BOILER NEAR A SOURCE OF FLAMMABLE LIQUIDS or gases may cause fire or explosion.

CLEAN BURNERS DAILY if operating the boiler in a dusty environment.

PROTECT IGNITION SYSTEM COMPONENTS from sources of water that may spray, drip, or rain on them during installation or service.

1. Slide the boiler into desired location.
2. Meet the minimum clearances to combustible construction per the *Specification* Section of this manual.
3. Allow 24" service clearance in front and on the left side of the boiler.
4. Level the boiler, using shims as necessary.

3. PROVIDE COMBUSTION AIR

! INSUFFICIENT COMBUSTION AIR SUPPLY may result in the production and release of deadly carbon monoxide (CO) into the home which can cause severe personal injury or death.

Like all fuel-burning appliances, boilers need air to operate reliably and safely.

Provide combustion air using the instructions in *Appendix A—Combustion Air*.

4. CONNECT VENTING

! IMPROPER VENTING may result in property damage and the release of flue gases which contain deadly carbon monoxide (CO) into the home, which can cause severe personal injury, death or substantial property damage.

The vent system shall be designed and constructed in accordance with NFPA 54 and applicable local codes to develop a positive flow adequate to convey flue or vent gases to the outdoors, while ensuring that flue gases do not cool prematurely.

Observe all general venting guidelines provided in *Appendix B—Venting*. Additionally:

1. This appliance shall be vented into a listed gas vent, masonry, metal, or factory-built chimney as required by NFPA 54 and applicable local codes for Category I appliances. If venting this appliance into a masonry chimney, the chimney must be lined with a listed chimney lining system

(i.e. Type B gas vent or flexible metal) as required by NFPA 54 and applicable local codes. Clay flue lined masonry chimneys do not meet the venting requirements for this appliance.

2. Attach the vent damper with three sheetmetal screws around the perimeter of the flue collar (Figure 4-a), oriented so that the position indicator is visible. The vent damper may also be mounted anywhere between the flue outlet and the chimney within reach of the electrical harness.
3. Vent connector shall be double-wall insulated gas vent as supplied with this boiler or Type B (double-wall) gas vent only. Using sheetmetal screws, attach the vent connector between the vent damper and the vertical chimney (Figure 4-b). Do not exceed the maximum vent connector length in Table 4.1.

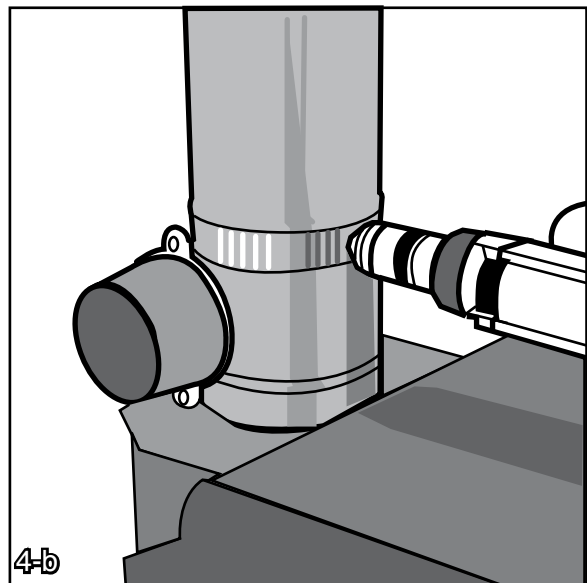

! DAMPER MUST BE OPEN when the main burner is firing.

4. CONNECT VENTING (continued)

Table 4.1: ES2 Vent Connector - Horizontal Length Restrictions (ft)

Model	ES23	ES24	ES25	ES26	ES27	ES28	ES29
Input (MBH)	70	105	140	175	210	245	280
Minimum Vent Diameter (in)	4	5	6	6	7	7	8
Vent Height (ft)	With B-Vent (double wall) Vent Connector						
6	0	0	6	0	4	0	2
8	8	8	8	2	8	2	8
10	10	10	10	10	10	10	10
15	15	15	15	15	15	15	15
20	20	20	20	20	20	20	20
30	20	30	30	30	30	30	30
50	20	30	30	30	30	30	30
100	20	30	30	30	50	50	50

5. CONNECT GAS PIPING

Size gas piping according to *Appendix C – Gas Piping*



SHUT OFF GAS SUPPLY before servicing the boiler.



ALL GAS PIPING MUST BE GAS TIGHT. Use gas rated thread compound on all threaded joints to avoid leaks, which may result in fire or explosion.



SIZE GAS PIPING, regulators, valves, and meters so as to provide an adequate gas flow and pressure to the boiler during operation. Failure to do so may cause poor combustion, noise, injury, or death.

1. Remove boiler door, locate gas valve and remove plastic shipping plug.
2. Thread a 3/4" x 1 1/2" nipple, a 90° street elbow, or a Honeywell flange onto the gas valve and pipe through the slot in the left jacket panel (Figure 5-a). In Canada, close

nipples and street ells are not approved for use as gas piping.

3. Pipe through the left jacket panel, and complete drip leg as shown (Figure 5-a).

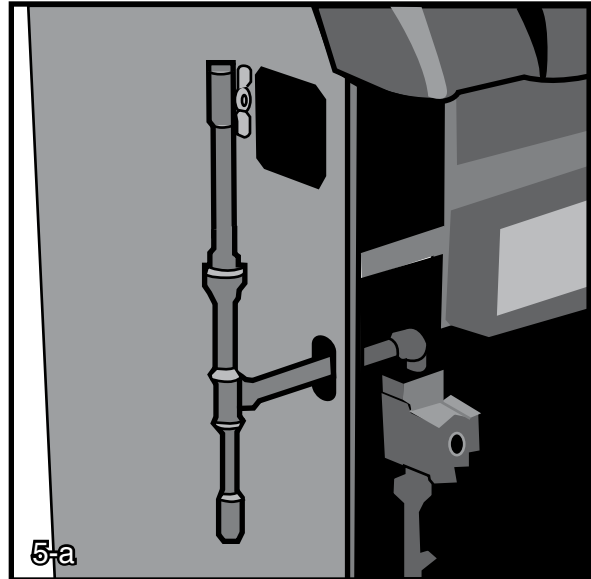

6. CONNECT BOILER WATER PIPING

General system piping guidelines are included in *Appendix D—System Piping*.

Additionally, for this particular boiler install piping shown below (Figure 6-a).

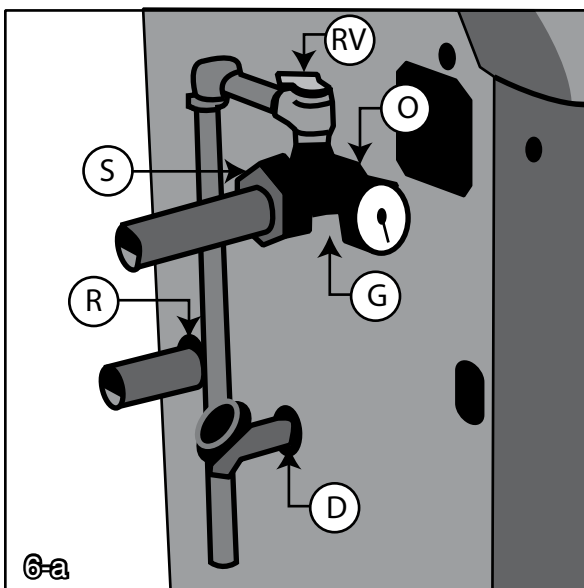

1. Apply sealant to all threads.

2. Screw the water supply manifold into the boiler outlet tapping "O."
3. Orient the manifold with the relief valve on top.
4. Screw the relief valve into manifold tapping "RV".



This installation is not complete until the relief valve is installed.



PIPE THE RELIEF VALVE DISCHARGE to a location where it will not harm people or damage property. The relief valve may discharge scalding hot water or steam.



BLOCKING THE RELIEF VALVE may result in boiler explosion.

5. Screw the temperature-pressure gage into manifold tapping "G".
6. Connect the system supply to the open end of the manifold "S" using a 1 1/4" male NPT fitting.

6. CONNECT BOILER WATER PIPING (continued)

7. Screw an installer-supplied 1 ¼" pipe or nipple into the water return tapping "R".
8. Screw the supplied drain valve into tapping "D".

9. See Figure 6b for suggested near boiler piping of IQ Options.

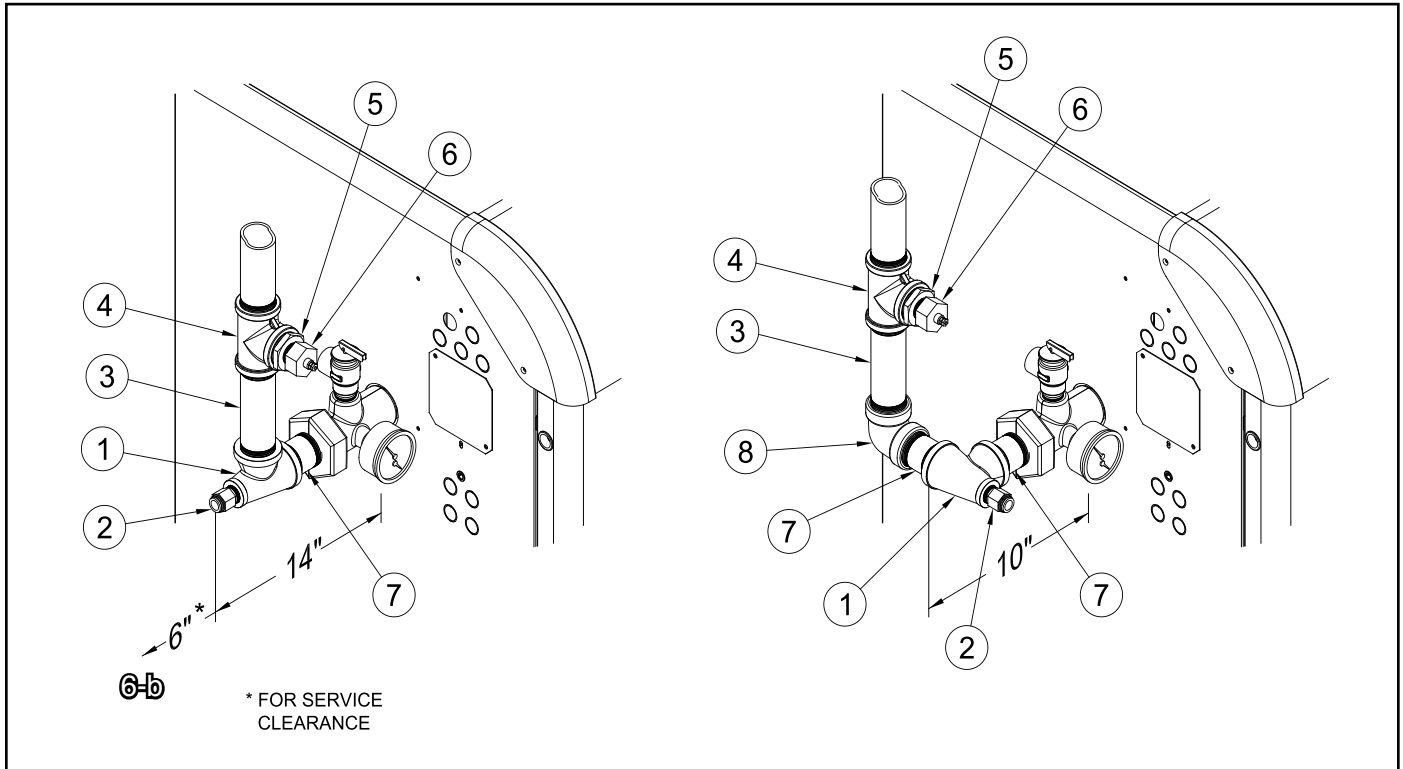

Item	Description	Burnham Part Number
1	1 ¼ x 1 ¼ x ½ Tee	806601021
2	Immersion Well, ½ NPT	80160456
3	1 ¼ x 6 Nipple	806600029
4	1 ¼ Tee	806601030
5	1 ¼ x ¾ Bushing	806600504
6	LWCO Sensor, ¾ NPT	102305-01
7	1 ¼ x 3 Nipple	806600005
8	1 ¼ Elbow	806601528

7. CONNECT ELECTRICAL WIRING

! DISCONNECT ELECTRICAL POWER to the boiler and heating system before servicing. Positively assure that no voltage is present. Lock electrical boxes to prevent someone from inadvertently restoring power before the heating system is safe to operate.

! NEVER DEFEAT OR JUMP OUT safety devices.

! PROTECT EACH BOILER circuit with a properly sized over-current protection device.

! MAKE ELECTRICAL CONNECTIONS CAREFULLY according to the boiler's wiring diagram and instructions

Refer to the *Internal Wiring* diagrams later in this manual.

1. Locate the wiring box on the left side of the boiler and open the cover (Figure 7-a).
2. Install a 120V disconnect near the boiler.
3. Connect the 120V wiring from the disconnect to the boiler's white (neutral), black (hot), and green (ground) labeled "120VAC Power supply". Do not reverse polarity.
4. Connect the 120V wiring from the circulator to the white (neutral) yellow (hot) wires marked "circulator".

! WIRE AN ADDITIONAL SAFETY LIMIT such as a low water cutoff or temperature limit device, other than an IQ™ Control device, in series with the 120V circuit used to power the boiler. Do not alter the boiler's factory wiring when adding an additional limit.

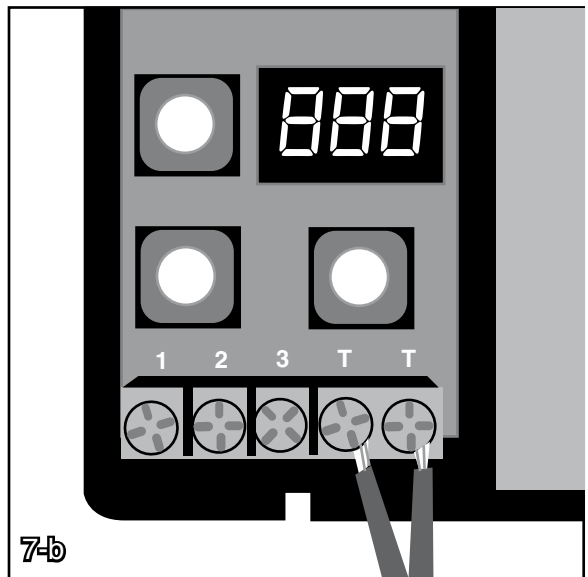
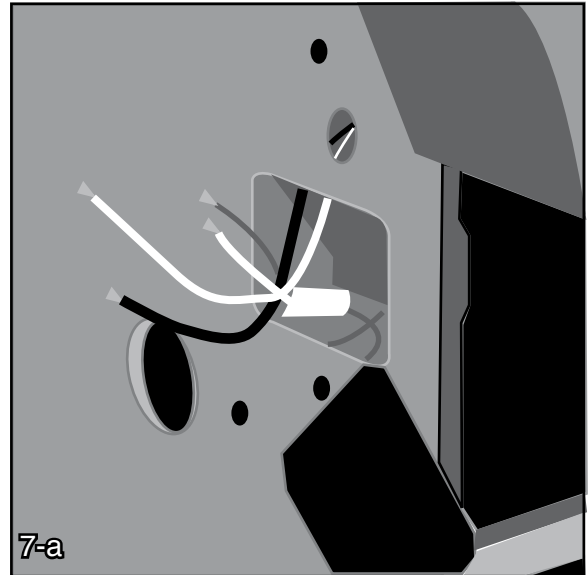

5. Connect the 24V wiring from the thermostat to the "T-T" terminals on the Option Control Panel.
6. To connect other external devices, refer to the instructions included with these devices.

8. PROGRAM THE CONTROLS

Using IQ Boiler Control Display

The IQ Boiler Control is located inside the boiler front door, just above the IQ Option Panel (Figure 8-a).

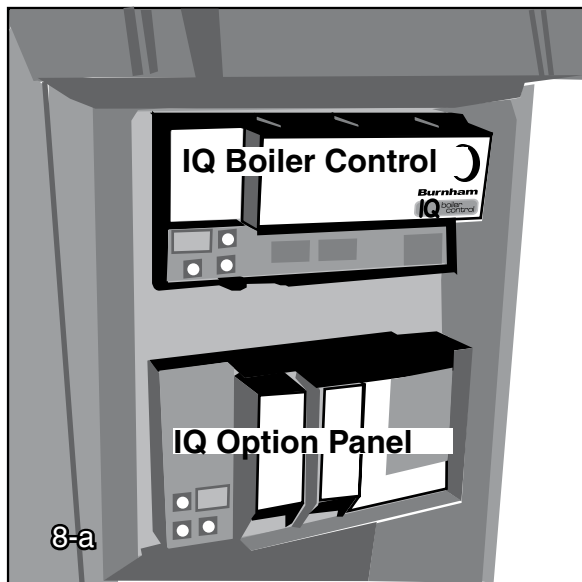

The IQ Boiler Control display, along with Up ↑, Down ↓, and “I” keys may be used to view boiler operating status (Figure 8-b). Please note that these keys look similar to the keys on the IQ Option Panel but are in a different orientation, and they perform different functions.

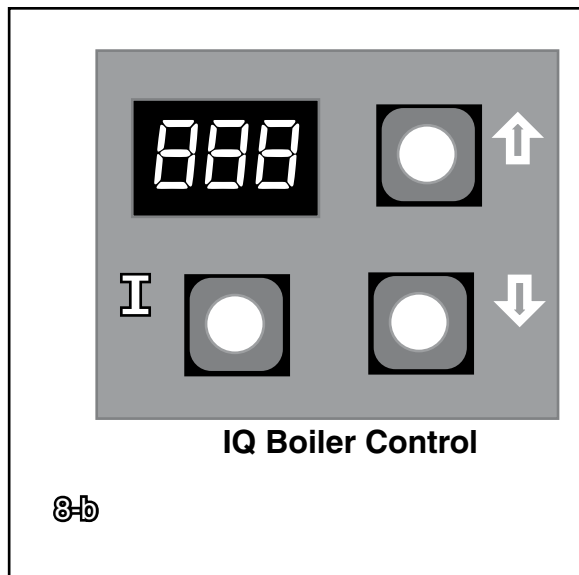

Viewing the Operating Mode Options

In operating mode the user may view (but not change) boiler operating status, settings and troubleshooting information. To view IQ Boiler Control display information:

1. Press and release the “I” key on the IQ Boiler Control to change from one parameter to the next. Each setting will alternately flash between the relevant display code and its corresponding value.

Operating Mode Options	
<i>StA</i>	Status
<i>bT</i>	Boiler Temperature
<i>SP</i>	Operating Setpoint (Outdoor Reset)
<i>HL</i>	High Limit Setting
<i>HdF</i>	High Limit Differential
<i>hr</i>	Heat Request Status
<i>FLA</i>	Flame Current
<i>rUn</i>	Run Time Hours
<i>CYC</i>	Boiler Cycles
<i>Err</i>	Error (see Error Numbers)

Status Code Displayed in <i>StA</i> Mode	
1	Standby: Either TT Open or TT Closed and Boiler Temperature within Setpoint & Differential with circulator running.
4	Prepurge
6	Spark
7	Flame Proving
8	Running
10	Retry/Recycle Delay
13	Soft Lockout
14	Hard Lockout
15	Waiting for Limit to Close
16	Flame Present Out of Sequence
17	Self Test
18	Waiting for Damper to Open
19	Waiting for Damper to Close
20	Damper Failure to Open
21	Damper Failure to Close

For example, when the “I” key is pressed on the IQ Boiler Control until “*bT*” is displayed, it will then flash a three digit number (such as “180”) followed by either “F” (or “C”). This indicates that the boiler water temperature is 180°F. Other operating parameters display the information in a similar fashion.

8. PROGRAM THE CONTROLS (continued)

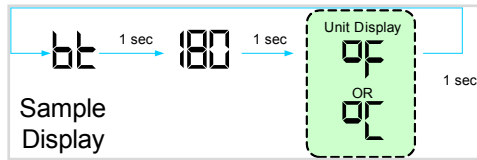

Please note that in operating mode to hold the display on the value the user can press and hold either the Up ↑ or Down ↓ keys and the value will be continuously shown. This may be helpful in watching a value “live”.

Changing the Adjustable Parameters

To adjust the High Limit setpoint, High Limit Differential or Pump Overrun time settings or setting the display for either °F or °C temperature readings:

1. Access the adjustment mode by pressing and holding the Up ↑, Down ↓, and “**⏏**” keys simultaneously for three (3) seconds. This procedure is intended to discourage unauthorized changes or accidental changes to limit settings.
2. Press the “**⏏**” key to display available Adjustment Mode options. Select an option.

Adjustment Mode Options	
HL_	Adjust High Limit Setting
dF_	Adjust High Limit Differential
Or_	Pump Overrun Time (minutes)
r5t	Reset Lockout
F-[]	Select degrees F or C Mode
bRc	Back to Operating Mode

3. Press the Up ↑ and Down ↓ keys to adjust the displayed setpoint to the desired value.
4. To return to the normal operating mode from the Adjustment Mode, when the “bRc” option is displayed, press either the Up ↑ or Down ↓ key. If no keys are pressed, after five (5) minutes the IQ Boiler Control will automatically return to the Operating Mode.

More Information about Adjustable Parameters

1. High Limit (HL_)
The IQ Control is factory programmed

with a High Limit Setpoint of 180°F. The boiler turns "off" when the supply water temperature is above this value. The High Limit setpoint is adjustable between 130° and 220°F. The Operating Setpoint (SP) will equal the High Limit Setpoint unless an IQ Outdoor Reset IQ Option Card is installed. The Outdoor Reset IQ Option Card reduces the Operating Setpoint to regulate heat delivery, increase home comfort and save energy. Refer to the *Appendix H* for additional information.

2. Differential (dF_)
The IQ Boiler Control is factory programmed with a Differential of 15°F. The Differential is the number of degrees the supply temperature must decrease below the Operating Setpoint before the boiler can restart. The differential is adjustable between 10° through 30°F.
3. Pump Overrun Time (Or_)
The IQ Boiler Control is factory programmed with a Pump Overrun Time of 0 minutes. Pump Overrun Time (also called “off delay” or “post purge”) continues pump operation after a call for heat has ended, sending excess heat from the boiler into the priority zone. Ensure system piping and zone panel settings allow water flow to the priority zone after the call for heat ends. The Pump Overrun Time is adjustable between 0 through 10 minutes.

Using the IQ Option Panel

IQ Option Cards are available from Burnham distributors and are the simplest way to add functionality, safety and efficiency to your heating system. The IQ Option Panel provides an easy and convenient means to "plug-in" an Auxiliary High Limit, Low Water Cut-off and/or Outdoor Reset function.

For installation, programming, and troubleshooting instructions, refer to the instructions supplied with those cards.

8. PROGRAM THE CONTROLS (continued)

Using the Optional LCD Display Kit

The LCD Display is an easy to use touch screen type display that allows a technician to monitor and adjust the IQ Boiler Control and connected IQ Option Cards. All boiler settings, status and error codes are displayed in full text. All Outdoor Reset IQ Option Card parameters are adjustable

with graphic and help information screens. The LCD Display Kit includes a mounting bracket and wiring harness to allow mounting in the ES2 plastic hood above the front door. For installation, programming, and troubleshooting instructions, refer to the instructions supplied with the display.

9. CHECK FOR GAS AND WATER LEAKS



GAS LEAKS may result in fire or explosion.

Refer to *Appendix E – Filling the System and Checking for Leaks*



WATER LEAKS may cause extensive property damage.

10. PERFORM STARTUP CHECKS AND ADJUSTMENTS

! FAILURE TO PERFORM THESE CHECKS of the boiler's combustion and safety systems may result in serious property damage, injury, or death.

! IF YOU SMELL GAS, STOP and repair the leak. Lighting the boiler when gas is leaking may cause explosion or fire.

Follow the checklist below:

1. Verify that the venting, water piping, gas piping, and electrical systems are properly installed and checked.
2. Apply power to the boiler.
3. Adjust zone thermostat to maximum setting.
4. Allow gas line to purge of air.
 - Boiler lights cleanly within 60 seconds.*
5. Adjust gas input rate. See *Appendix F – Adjusting Gas Input Rate*

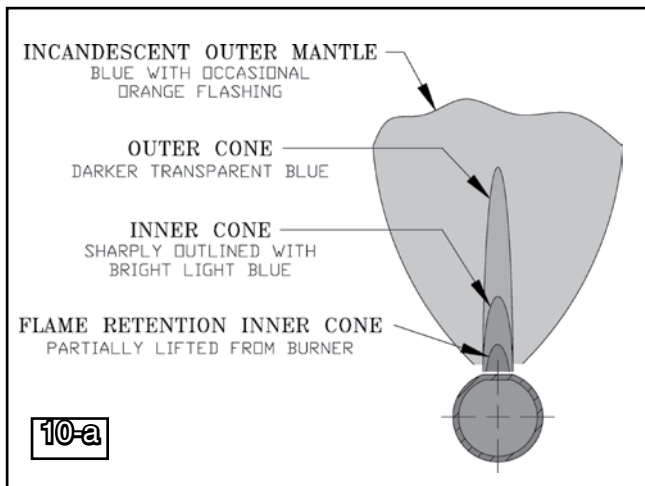

Pilot and main burner flames appear clean and blue.

6. Disconnect pilot lead wires from gas valve (Figure 10-b).
 - Boiler shuts off.*
7. Reconnect pilot lead wires to gas valve.
 - Boiler restarts.*

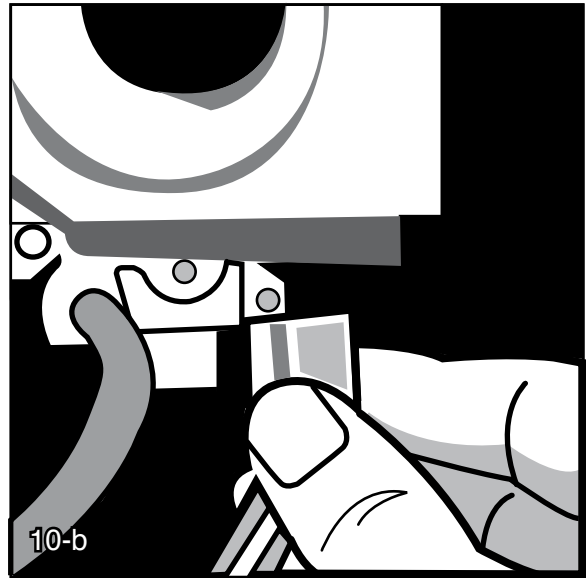

8. Adjust zone thermostat to minimum setting.
 - Boiler shuts off.*
9. Adjust zone thermostat to maximum setting.
10. Observe temperature gage as boiler heats.
11. Adjust the high limit setting to its minimum level (see "Programming High Limit" in Section 8).
 - Boiler shuts off when temperature gage reads within 15°F of high limit setting.*
12. Return high limit to the desired setting (see "Programming High Limit" in Section 8).
13. Check draft. See *Appendix G – Checking Draft and Combustion*.
 - No spillage observed.*
14. Check combustion in the vent stack and record results in the spaces provided below.

_____	CO ₂	(less than 7%)
_____	O ₂	(more than 9%)
_____	CO	(less than 100 ppm, air free)

! ANY FAILED STARTUP CHECK Must be corrected before placing the boiler in service.

ANNUAL MAINTENANCE CHECKLIST



WARNINGS

THE BOILER CONTAINS REFRACTORY CERAMIC FIBER, a possible human carcinogen. Use a NIOSH approved respirator when servicing high-temperature insulation and gasket materials. Wash exposed skin gently with soap and water after contact. Wash exposed clothing separate from normal laundry.

LABEL ALL WIRES prior to disconnection when servicing controls. Wiring errors can cause improper and dangerous operation.

FAILURE TO MAINTAIN THE BOILER in proper working condition may lead to fire, explosion,

personal injury or death, and extensive property damage.

TURN OFF ALL GAS AND ELECTRIC power supplies to the boiler before servicing. Contact with or release of dangerous flammable gas, electrical voltage, moving parts, and very hot water under pressure may cause serious personal injury, property damage, or death.

LOCK ELECTRICAL BOXES AND GAS VALVES CLOSED to prevent someone from inadvertently restoring power or gas before the heating system is safe to operate.

Equipment you will need:

- Soft bristle brush
- Bristle flue brush
- Vacuum with brush attachment

Perform these tasks each year:

1. Clean low water cutoff probe (if applicable).
2. Inspect vent for obstruction and signs of condensation, distortion, overheating or gas leakage.
3. Clean vent terminal and air intake screens.
4. Inspect boiler flue passages:
 - (1) Remove vent pipe, damper.
 - (2) Remove top panel and hood.
 - (3) Remove blocked vent switch and canopy.
 - (4) Examine all flue passageways. Using bristle flue brush and vacuum, remove any soot or obstructions.
5. Remove and clean main burners:
 - (1) Remove jacket front panel.
 - (2) Disconnect pilot tubing at gas valve.
 - (3) Disconnect pilot lead wires at gas valve.
 - (4) Remove wires from flame roll-out switch.
 - (5) Remove burner access panel.
 - (6) Mark location of the pilot main burner on the manifold if the marking on manifold is missing or obliterated.

- (7) Hold burner at throat. Lift front of burner to clear orifice (Figure AM-1). The burner that holds the pilot can only be removed by first lifting the burner adjacent to its right.

6. Perform *Startup Checks and Adjustments* described earlier in this manual.
7. Check operation of airflow sensing switches.
8. Check for water leaks on the boiler or water pooling around boiler.
9. Manually operate the relief valve. If the water is grey or black, there is excessive oxygen in the system. Oxygen is corrosive to boilers. Eliminate any source of oxygen.
10. Verify proper operation after servicing.

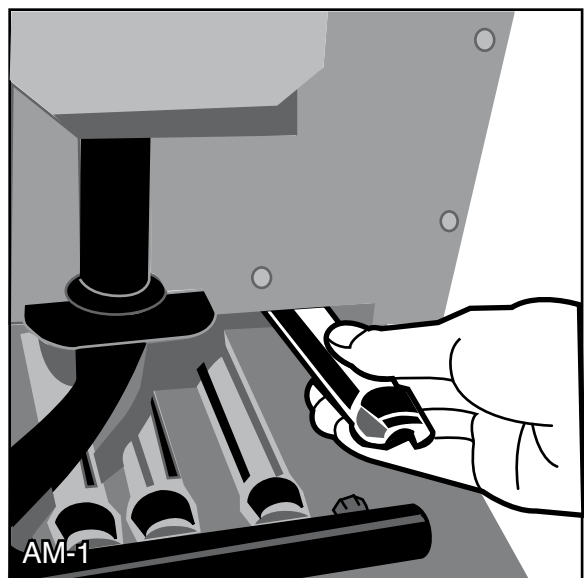

TROUBLESHOOTING

When a problem occurs with the boiler operation, the Burnham IQ Control System easily provides specific, valuable information to help resolve the issue quickly. The display on the IQ Boiler control should be the first place to check.

If "Err" IS NOT displayed on the IQ Boiler Control: Use the following table to determine the problem and possible causes.

IQ Boiler Control Status Codes (when "Err" is not displayed)		
Display	Status	Boiler / Control Action(s)
Blank	Boiler and Circulator off	No 120 Vac power at boiler, check breaker and wiring between breaker panel and boiler.
SEr 1	Boiler not responding to Heat Request	Boiler is not seeing Heat Request. Check thermostat or zone wiring for loose connection, miswiring, or defective thermostat or zone control.
SEr 8	Boiler Running but Circulator is not Running	Check wiring for loose connection, miswiring. When there is a Domestic Hot Water Heat Request wired to the Outdoor Air Reset card the Circulator will be off for the duration of the priority time. This to allow all of the boiler output to be provided for fast Indirect Water Heater recovery. Check Priority Time (PEL) function using Outdoor Air Reset IQ Option Card Adjustment Mode (see Reset Card Adjustment Mode instructions).
SEr 10	Retry Delay	The burner failed to light (no flame signal). After a 5 minute delay, IQ Control will attempt to light the burner again. There is no limit to the number of retries.
SEr 10	Recycle Delay	The burner loses flame during running mode (SEr code "B"). After a 10 second delay, IQ Control will attempt to light the burner again. If the burner loses flame during running mode (SEr code "B") during the next six recycles, IQ Control will progress to a soft lockout.
SEr 13	Soft Lockout	When a soft lockout occurs, boiler will shut down. Boiler automatically restarts once condition that caused the lockout is corrected and the one-hour time delay is completed. Boiler can be restarted sooner than the time delay by using Adjustment Mode function and manually resetting boiler (see Adjustment Mode instructions).
SEr 14	Hard Lockout	When a hard lockout occurs boiler shuts down. Boiler will NOT automatically restart once the condition that caused the lockout is corrected. It will be necessary to go to Adjustment Mode function to manually reset the boiler (see Adjustment Mode instructions).
SEr 15	Wait for Limit to Close	Heat Request occurs and start of operating sequence is halted due to an open limit. Open limits may include Flame Roll Out Switch, Blocked Vent Switch, or Auxiliary. Limit or Low Water Cutoff IQ Option Cards (when installed), refer to IQ Option Panel display for additional information.
SEr 16	Flame Out of Sequence	Flame Signal is still present when expected to be 0 (no flame).
SEr 18	Waiting for Damper to Open	Heat Request occurs and the IQ control is waiting for the damper to open (end switch to close).
SEr 19	Waiting for Damper to Close	The damper end switch is closed and the control waits for the damper end switch to open (*end switch is open when damper is closed). This is checked at the beginning of a heat cycle before opening the damper. If the damper doesn't close in 60 seconds, the IQ Control goes to Status 21.

TROUBLESHOOTING (continued)

IQ Boiler Control Status Codes (when "Err" is not displayed) - continued			
Display		Status	Boiler / Control Action(s)
Err	20	Damper Failed Open	The damper end switch has not closed (damper end switch is open) at the beginning of the heat cycle. An alarm message is sent but the control is not in lockout.
Err	21	Damper Failed Closed	The damper end switch has not opened (damper end switch is closed) at the beginning of the heat cycle. An alarm message is sent but the control is not in lockout.

If "Err" IS displayed on the IQ Boiler Control: "Err" flashes on the IQ Boiler control display followed by a number. Use the following table along with this error number to determine the problem and possible causes:

IQ Boiler Control Error Codes (when "Err" is flashing)			
Display		Status	Boiler / Control Action(s)
Blank		Boiler and Circulator off	No 120 Vac power at boiler, check breaker and wiring between breaker panel and boiler.
Err	4	Flame Current Lower than Threshold	Check pilot assembly.
Err	6	Flame Sensed Out of Normal Sequence	Flame sensed out of normal sequence (before opening gas valve or after closing gas valve).
Err	18	Electronics Failure	Replace Control .
Err	24	Flame Sensed During Post-Purge	Flame sensed during post-purge (after gas valve signaled closed).
Err	32	Temperature Sensor Failure	Temperature sensor or interface failure (open or short connection, increased connection resistance, dual sensor mismatch) or control hardware failure.
Err	55	Damper Failed to Open	Atmospheric Damper End Switch failed to close (end switch contacts stuck open).
Err	56	Damper Failed to Close	Atmospheric Damper End Switch failed to open (end switch contacts stuck closed).
Err	57	Flame Rod Shorted to Burner Ground	Flame Rod shorted to burner ground, this can result from excessive flue gas condensation.
Err	58	AC Line Frequency Error	AC Signal is too noisy or frequency is incorrect.
Err	59	Line Voltage Error	AC voltage out of specification high or low.
Err	60	Thermostat Input Higher than Threshold	Check thermostat wiring.
Err	61	Line Voltage Unstable	Possibly too many heavy loads switching on and off cause erratic supply voltage.
Err	63	Soft Lockout - Maximum Recycles Exceeded	Maximum number of recycles exceeded.
Err	64	Soft Lockout - Internal Failure	Caused by general electronics failure such as relay open or shorted contacts, flame sensing circuit error, or A to D error.

TROUBLESHOOTING (continued)

If IQ Boiler Control Shows Status Code "SLA 15": The IQ Boiler Control is "Waiting for Limit to Close" and the display on the IQ Option Panel should be the first place to check. The IQ Option Panel display (lower display) will show one of the following status codes:

IQ Option Panel Display Shows "Err"			
Display	Status	Boiler / Control Action(s)	
Err	1	Low Input Voltage	AC voltage is too low
Err	2 - card #	IQ Option Card Type Change without Re-Learn	Whenever a new IQ Option Card is <u>first</u> installed into the IQ Option Panel, the IQ Option Panel automatically "Learns" the card. This means it detects the specific card and lists it as a card number (E1, E2 or E3). However, to help avoid errors or unauthorized option card changes, once an IQ Option Card is initially installed, the IQ Option Panel will <u>not</u> automatically "Learn" a different card in the same slot. In this situation, the IQ Option Panel has to "Learn" about the new card manually. To have the IQ Option Panel recognize or "Learn" about a different card, the user must press the LEARN key on the IQ Option Panel until "Learn" is displayed. Then press and hold either the Up ↑ or Down ↓ key for at least three (3) seconds. The IQ Option Panel will then recognize and "Learn" the new IQ Option Card.
Err	3 - card #	IQ Option Card Communications Error	The IQ Option Card is not installed properly or has an internal fault. Remove the card and check for bent IQ Option Panel card interface pins. Straighten bent or misaligned pins or choose another card slot and reinstall card. If problem persists, replace card.
Err	4 - card #	IQ Option Card Hardware Interface Error	The IQ Option Card is not installed properly, there is a option card or IQ Option Panel fault. Remove the card and check for bent IQ Option Panel card interface pins. Straighten bent or misaligned pins or choose another card slot and reinstall card. If problem persists, replace card.
Err	5	Limit Output OFF in ON State	Check limit string wiring, replace the IQ Option Panel.
Err	6	Incorrect Wiring	Check boiler wiring.
Err	7	Limit Output ON in OFF State	Check limit string wiring, replace the IQ Option Panel.
Err B	8	Internal IQ Option Panel Error	Replace the IQ Option Panel.

If IQ Option Panel Display Shows "OL": The OL - "card number" indicates the card slot causing the Open Limit. For example, "OL-1" means open limit in the card located in card slot 1. To determine the cause of the open limit the user must switch the display on the IQ Option Panel to show the view mode of the IQ Option Card installed in Slot 1.

For example, if, while the boiler has a Heat Request, and the Aquastat IQ Option Card installed in Slot 1 has a sensor failure the IQ Option Panel displays OL-1 (Open Limit Card Slot 1). To investigate the status of option card 1:

1. Press the "I" key on the IQ Option Panel. The display will go from "OL-1" to "I".
2. When the display shows "I", press either the Up ↑ or Down ↓ keys to switch the display to show the view mode of the Aquastat Limit Control IQ Option Card inserted in Slot 1. The display will now read Err - 119, Sensor Failure.
3. Check the sensor connections and when required replace the sensor.
4. When the sensor failure is corrected the IQ Option Panel will return to the "O.C.P" display and the IQ Boiler Control start sequence will continue.

For additional information refer to the instruction manual supplied with the IQ Option Card.

If IQ Option Panel Display Shows "O.C.P": The Option Panel is in normal run or operating mode, the IQ Option Panel display will show "O.C.P" (Option Card Panel) along with a floating decimal point that flashes on and off (the "heartbeat" flash indicating the panel is functioning properly and there are no open limits or errors). The Option Panel or the card installed in the option panel are not causing the open limit.

1. Check for loose boiler wiring and check flame roll out & blocked vent switches.

REPAIR PARTS LIST

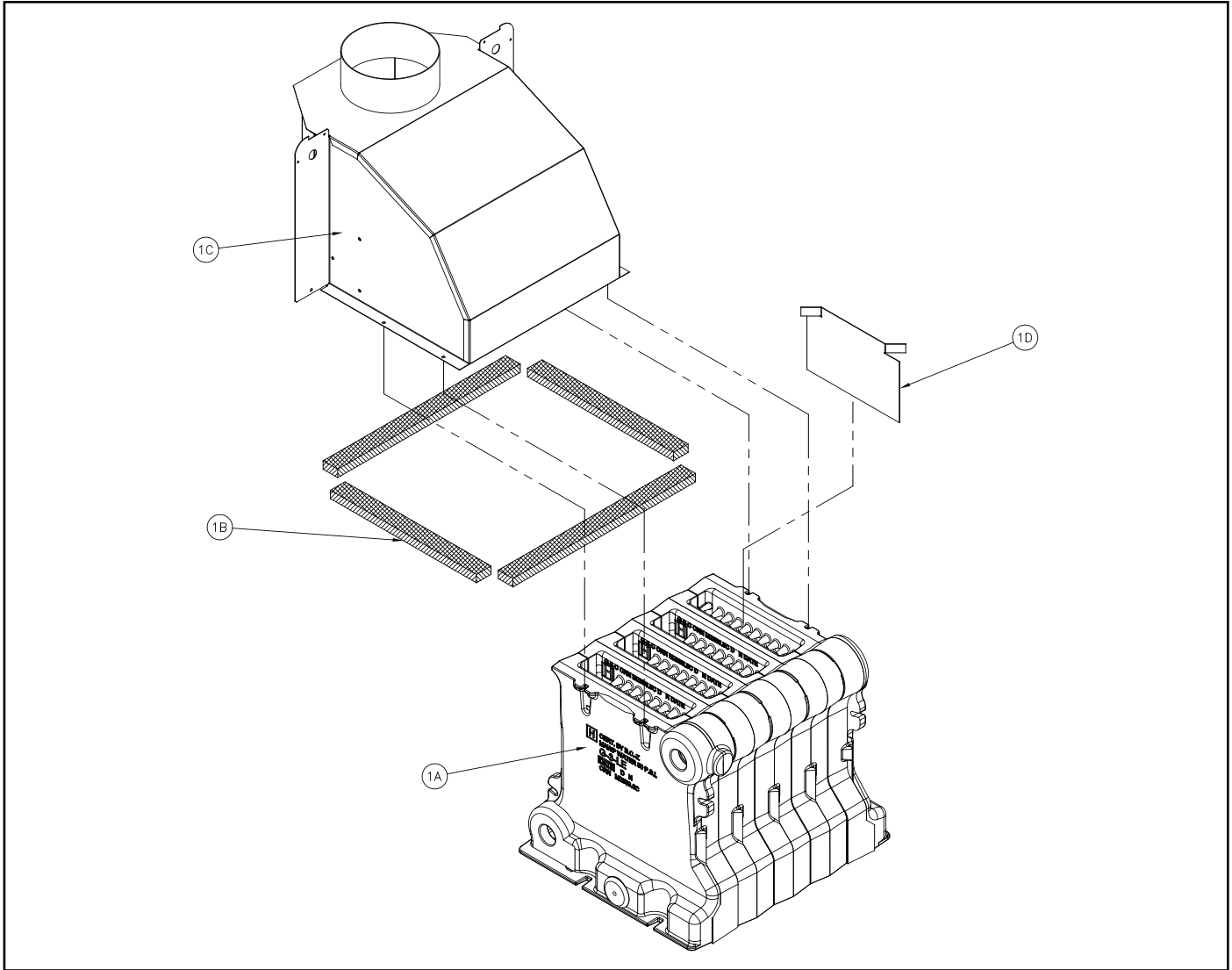

Key No.	Description	[Quantity] Part Number						
		ES23	ES24	ES25	ES26	ES27	ES28	ES29
1A	Block Assembly	102287-03	102287-04	102287-05	102287-06	102287-07	102287-08	102287-09
1B	Canopy Gasket Kit	6206001						
1C	Canopy Assembly	102554-03	102554-04	102554-05	102554-06	102554-07	102554-08	102554-09
1D	Flue Baffle	[2] 102678-01	[3] 102678-01	[4] 102678-01	[5] 102678-01	[6] 102678-01	[7] 102678-01	[8] 102678-01
	Blocked Vent Switch (not shown)	80160157						

REPAIR PARTS LIST (continued)

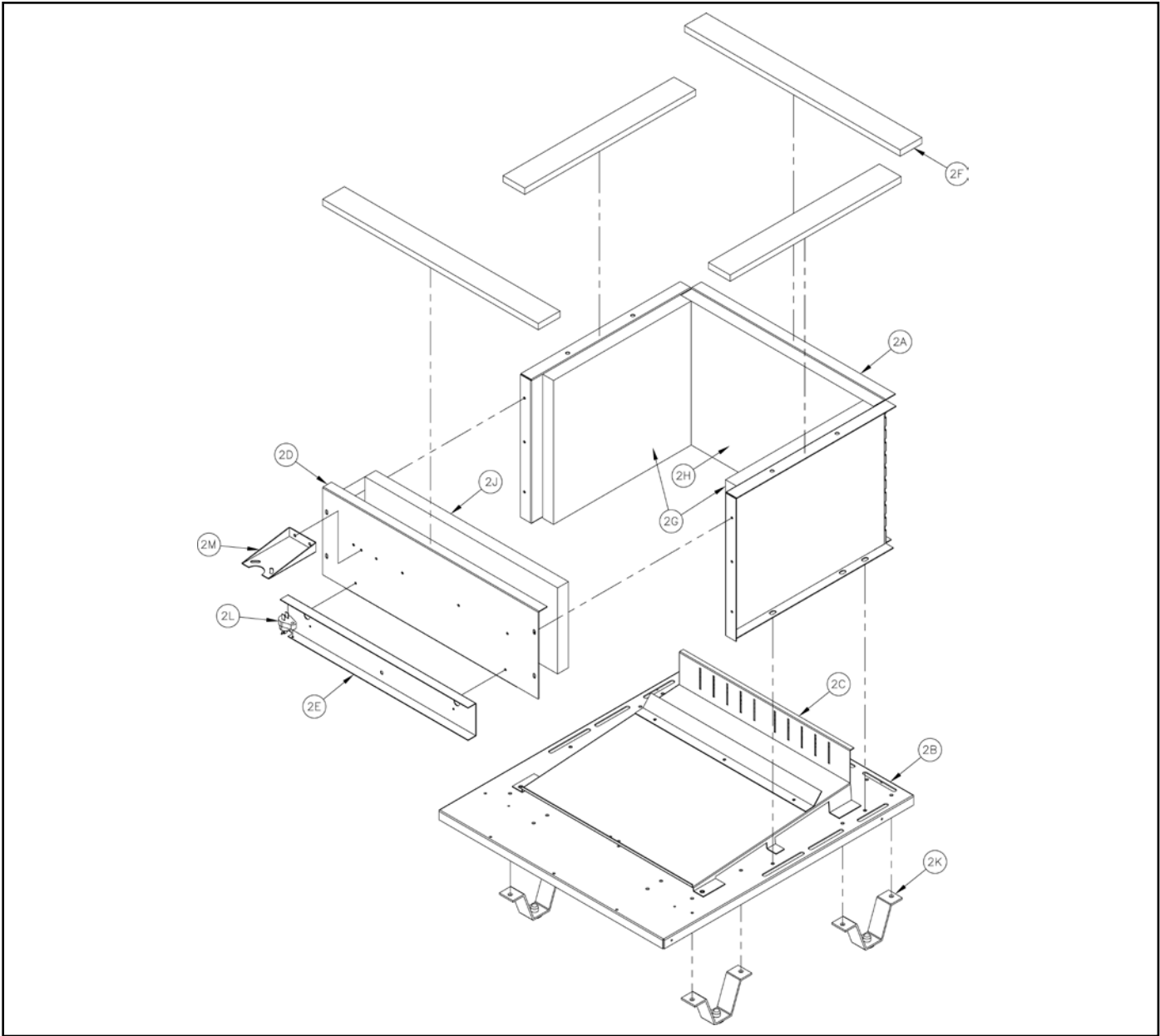

Key No.	Description	[Quantity] Part Number						
		ES23	ES24	ES25	ES26	ES27	ES28	ES29
2A	Base Wrapper	71807031	71807041	71807051	71807061	71807071	71807081	71807091
2B	Base Tray	102543-03	102543-04	102543-05	102543-06	102543-07	102543-08	102543-09
2C	Burner Tray Assembly	61807031	61807041	61807051	61807061	61807071	61807081	61807091
2D	Base Front Panel	71807035	71807045	71807055	71807065	71807075	71807085	71807095
2E	Burner Access Panel	102707-03	102707-04	102707-05	102707-06	102707-07	102707-08	102707-09
2F	Base Gasket Kit	6206002						
2G	Base Side Insulation	[2] 72007001						
2H	Base Rear Insulation	72007031	72007041	72007051	72007061	72007071	72007081	72007091
2J	Base Front Insulation	72007032	72007042	72007052	72007062	72007072	72007082	72007092
2K	Base Leg Assembly	[4] 6186001						
2L	Flame Roll-out Switch	80160044						
2M	Manifold Support Bracket	71807001						

REPAIR PARTS LIST (continued)

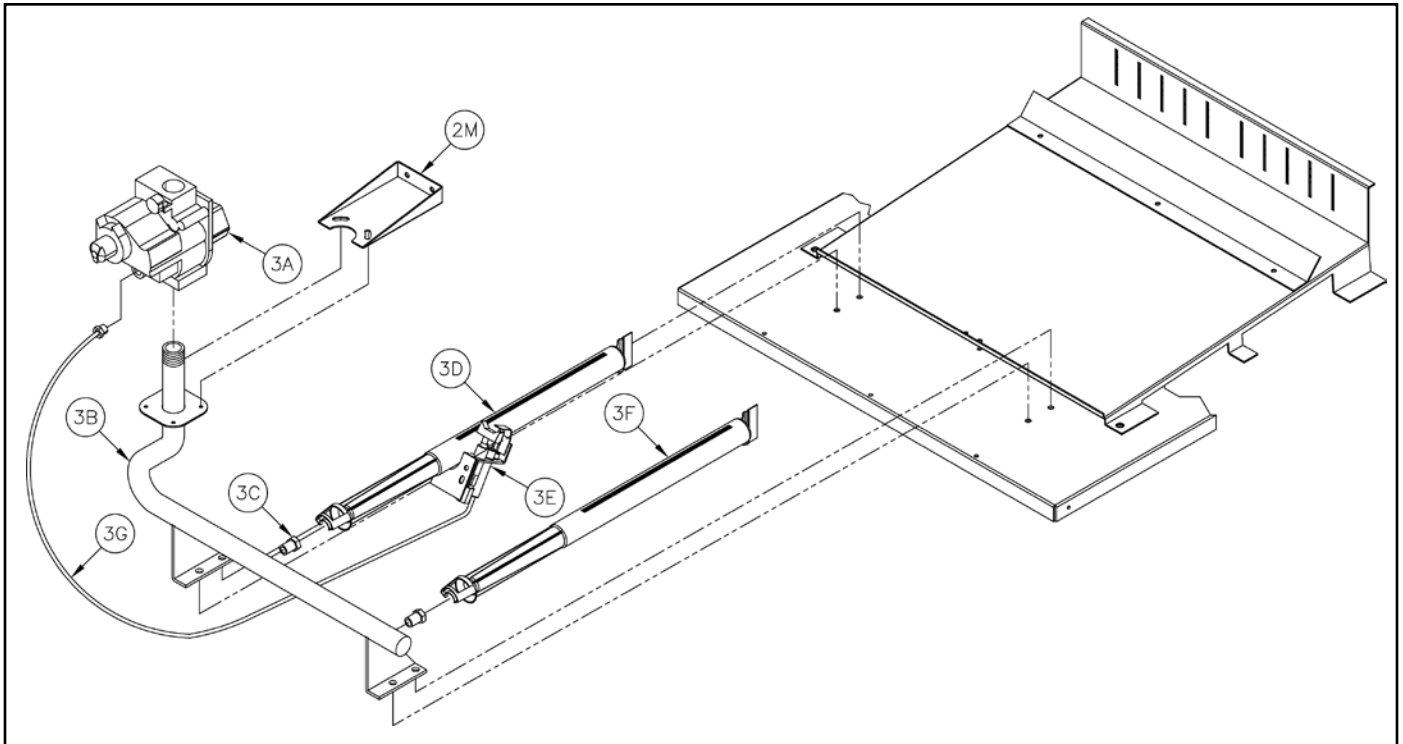

Key No.	Description	[Quantity] Part Number						
		ES23	ES24	ES25	ES26	ES27	ES28	ES29
3A	Gas Valve (Natural Gas), Honeywell VR8204P1171	81660282				N/A		
	Gas Valve (Natural Gas), Honeywell VR8304P4496	N/A				81660283		
	Gas Valve (LP Gas), Honeywell VR8204C3015	81660146				N/A		
	Gas Valve (LP Gas), Honeywell VR8304P4314	N/A				81660160		
3B	1/2" Gas Manifold	82207031	82207041	82207051	82207061	N/A		
	3/4" Gas Manifold	N/A				82207071	82207081	82207091
3C	Burner Orifices - Natural Gas #47	[4] 822710	[6] 822710	[8] 822710	[10] 822710	[12] 822710	[14] 822710	[16] 822710
	Burner Orifices - LP Gas 1.20mm	[4] 822792	[6] 822792	[8] 822792	[10] 822792	[12] 822792	[14] 822792	[16] 822792
3D	Pilot Burner					100147-01		
3E	Pilot Assembly - Natural Gas					102592-01		
	Pilot Assembly - LP Gas					102593-01		
3F	Main Burner	[3] 100146-01	[5] 100146-01	[7] 100146-01	[9] 100146-01	[11] 100146-01	[13] 100146-01	[15] 100146-01
3G	Pilot Tubing	8236122						

REPAIR PARTS LIST (continued)

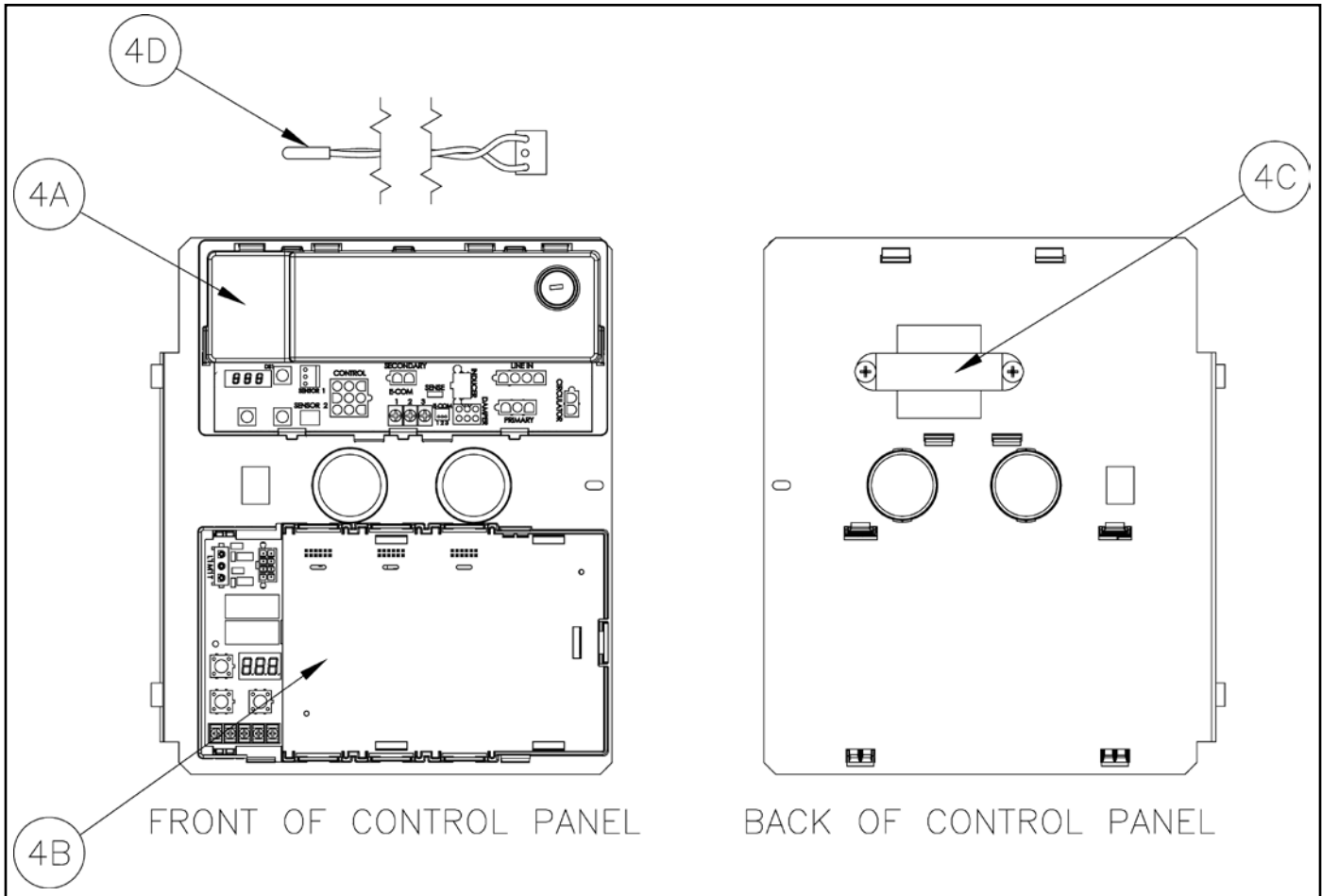

Key No.	Description	[Quantity] Part Number						
		ES23	ES24	ES25	ES26	ES27	ES28	ES29
4A	IQ Boiler Control				102289-01			
4B	IQ Option Panel				102291-01			
4C	Transformer				102516-01			
4D	Temperature Sensor				102411-01			

REPAIR PARTS LIST (continued)

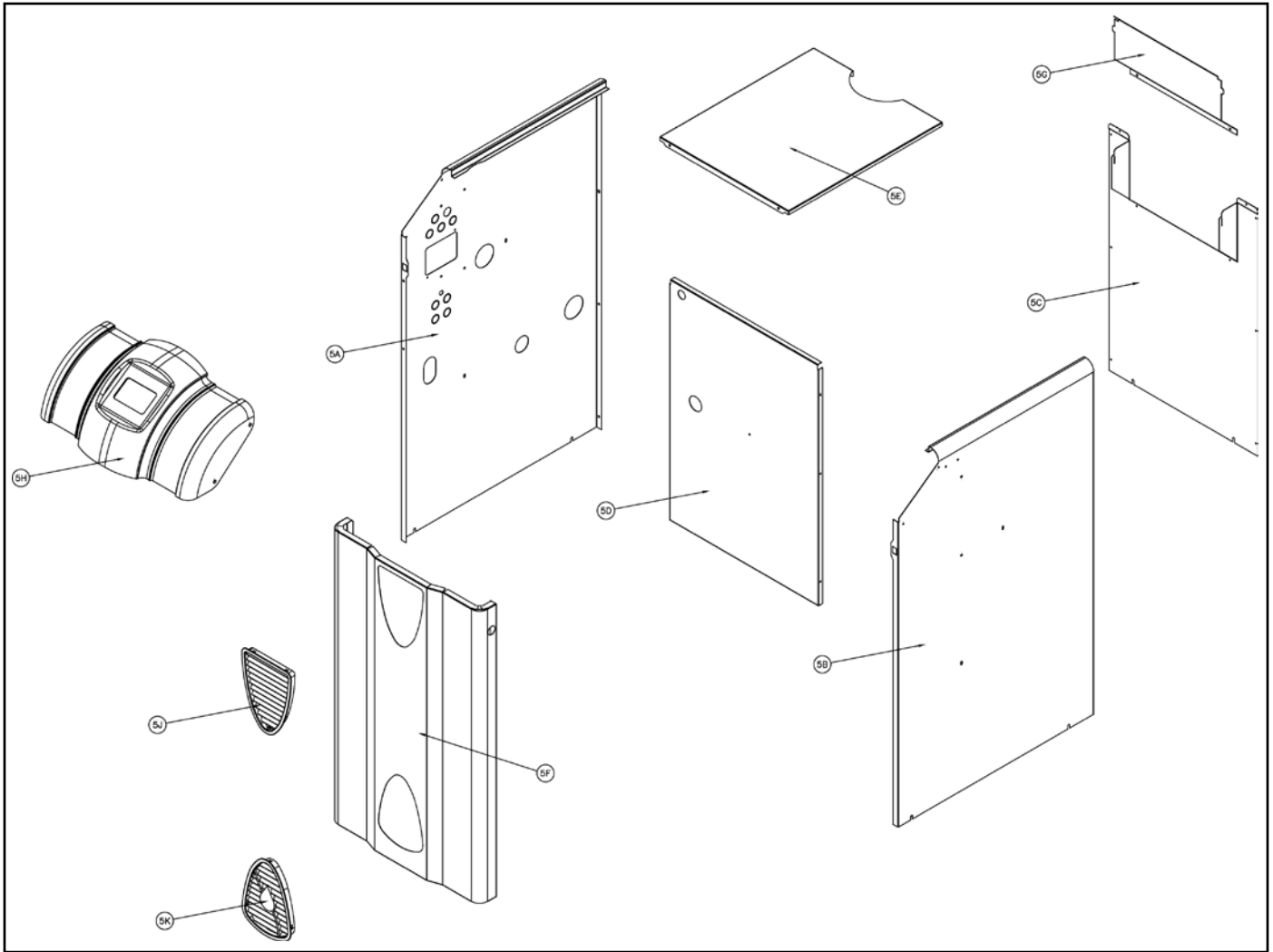

Key No.	Description	[Quantity] Part Number						
		ES23	ES24	ES25	ES26	ES27	ES28	ES29
5A	Jacket Left Side Panel				102566-01			
5B	Jacket Right Side Panel				102567-01			
5C	Jacket Rear Panel	102569-03	102569-04	102569-05	102569-06	102569-07	102569-08	102569-09
5D	Jacket Vestibule Panel	102565-03	102565-04	102565-05	102565-06	102565-07	102565-08	102565-09
5E	Jacket Top Panel	102568-03	102568-04	102568-05	102568-06	102568-07	102568-08	102568-09
5F	Jacket Front Door	102576-03	102576-04	102576-05	102576-06	102576-07	102576-08	102576-09
5G	Jacket Rear Discharge	102549-03	102549-04	102549-05	102549-06	102549-07	102549-08	102549-09
5H	Jacket Poly Front Cover	102600-03	102600-04	102600-05	102600-06	102600-07	102600-08	102600-09
5J	Upper Poly Grille				102621-01			
5K	Lower Poly Grille				102622-01			

REPAIR PARTS LIST (continued)

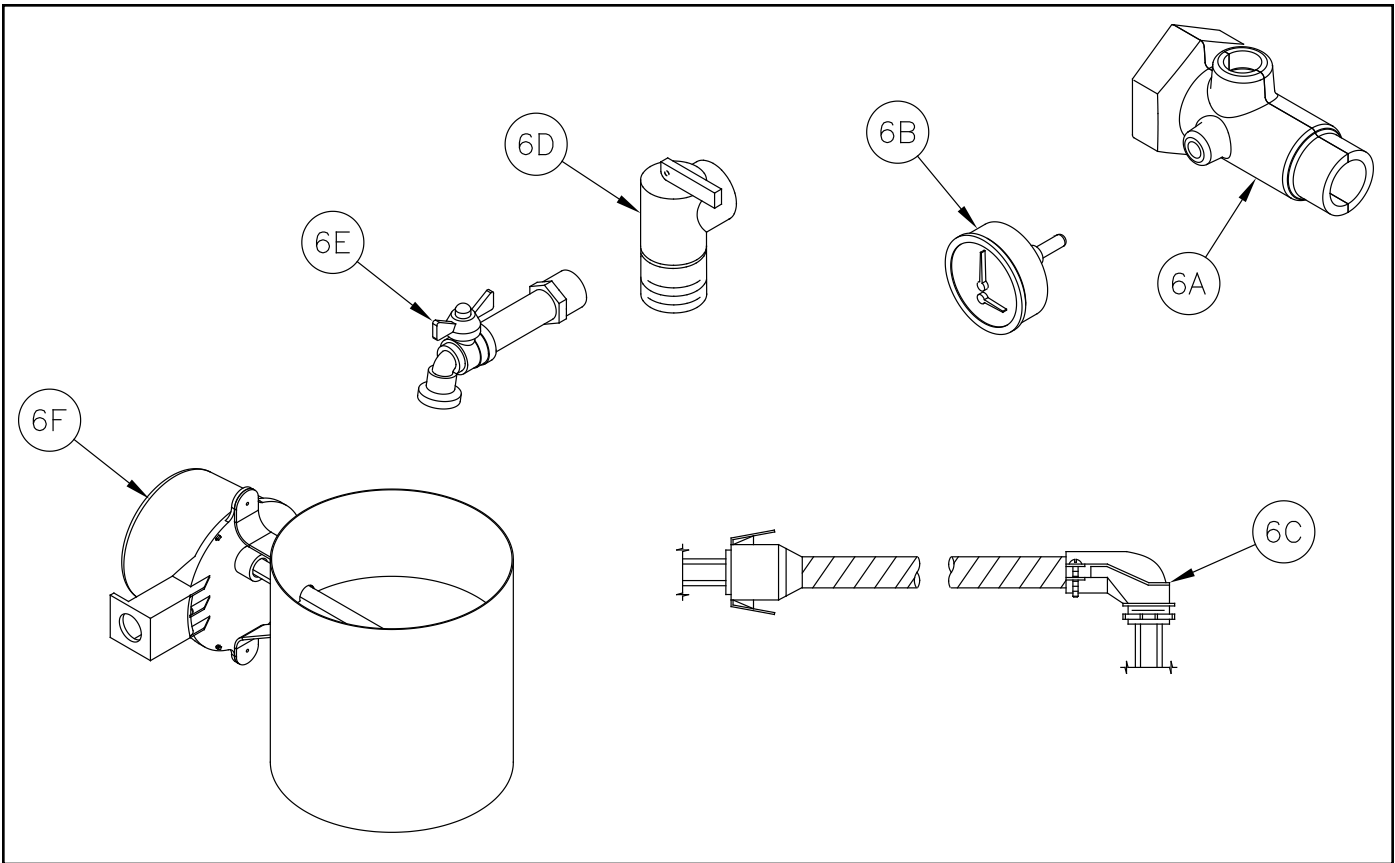

Key No.	Description	[Quantity] Part Number						
		ES23	ES24	ES25	ES26	ES27	ES28	ES29
6A	Supply Water Manifold				80607001			
6B	Temperature/Pressure Gauge				100282-01			
6C	Circulator Wiring Harness				6130701			
6D	30 PSI Relief Valve				81660363			
6E	Drain Valve				102802-01			
6F	Vent Damper	102284-01	102284-02	102284-03		102284-04		102284-05
	Circulator (not shown):							
	Taco 007-2				8056170			
	Grundfos UP-15				102805-01			
	B & G NRF-22				8056174			

INTERNAL WIRING

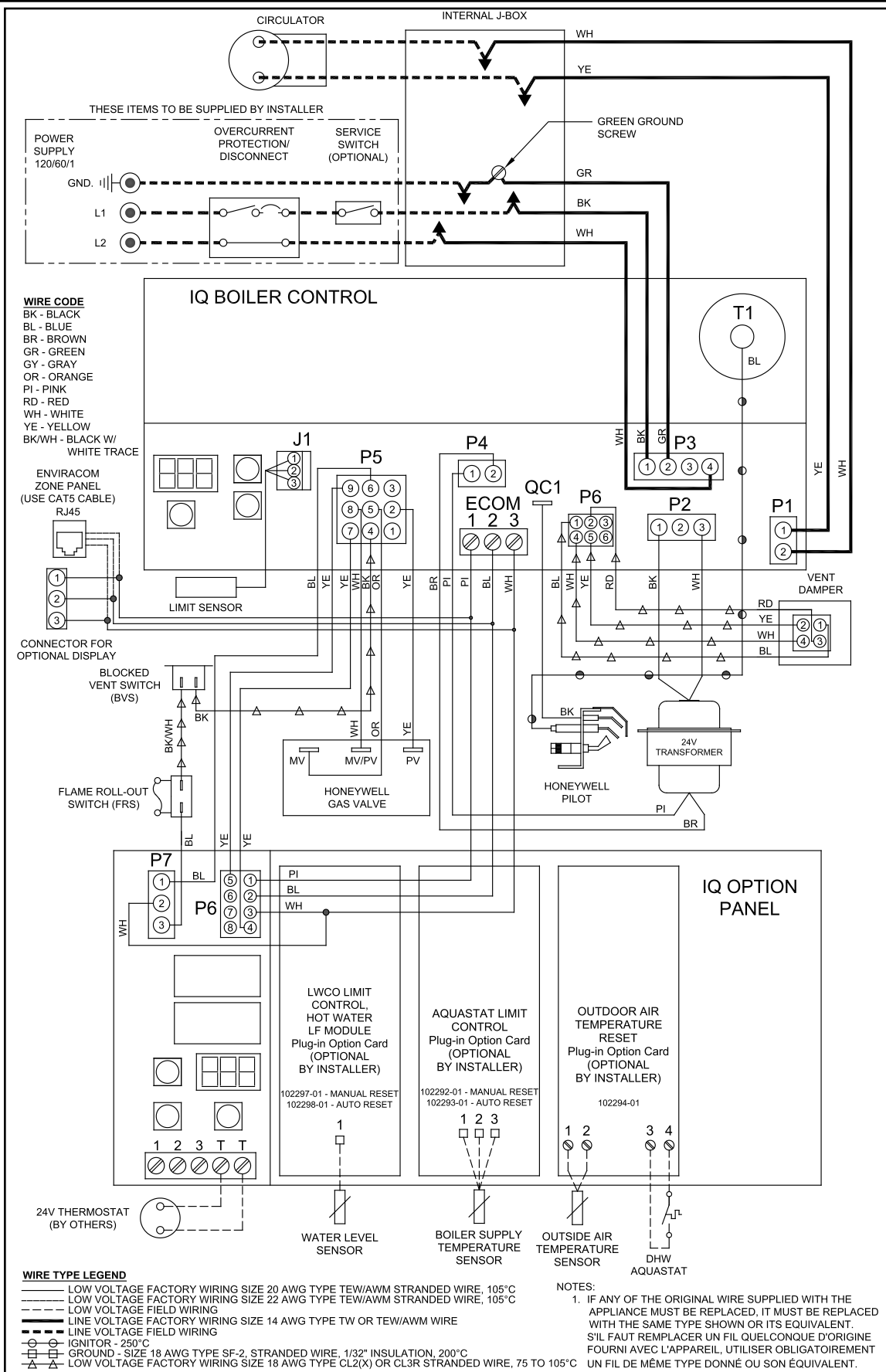

Figure IW-1: Wiring Diagram

INTERNAL WIRING (continued)

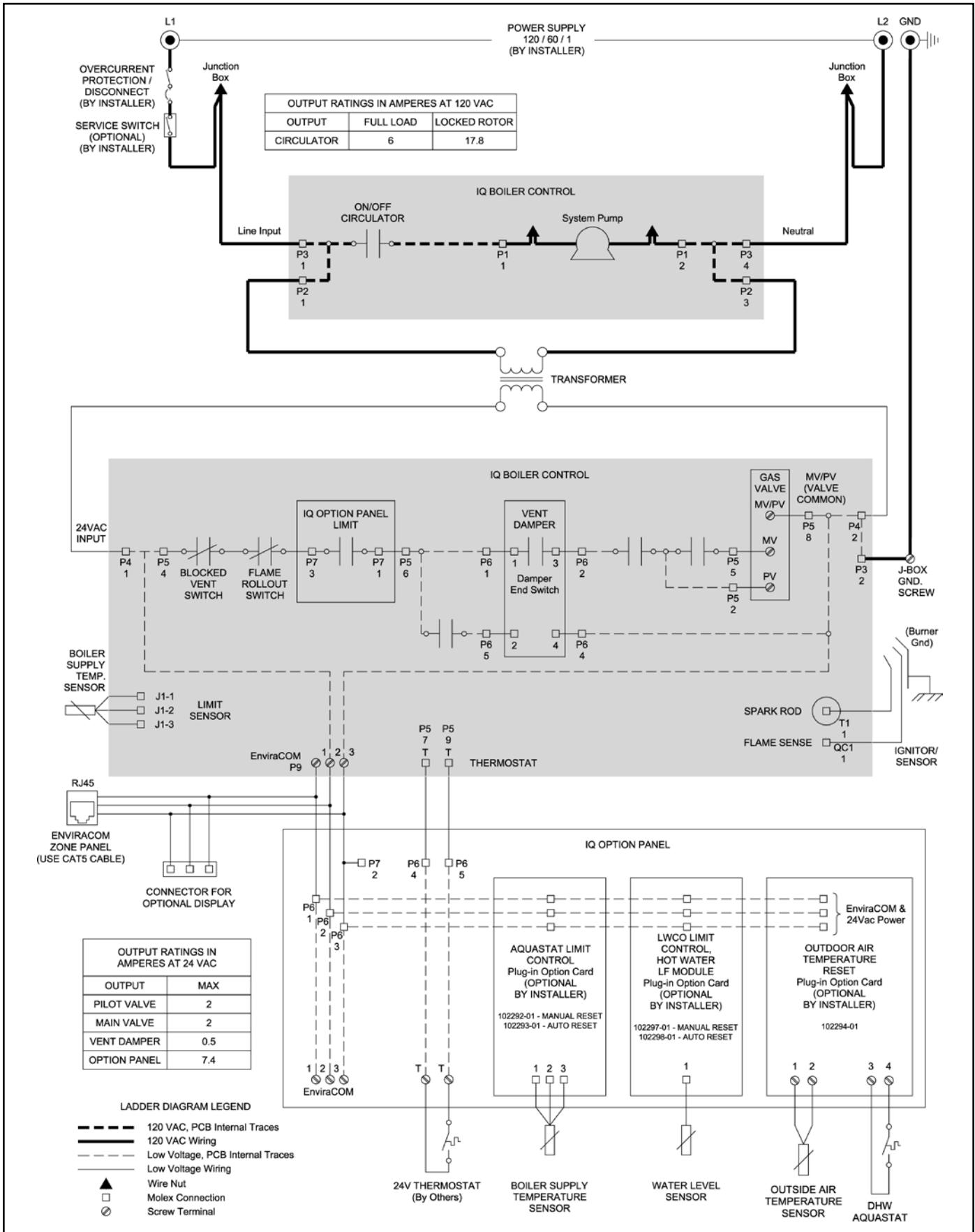

Figure IW-2: Wiring Schematic

INTERNAL WIRING (continued)

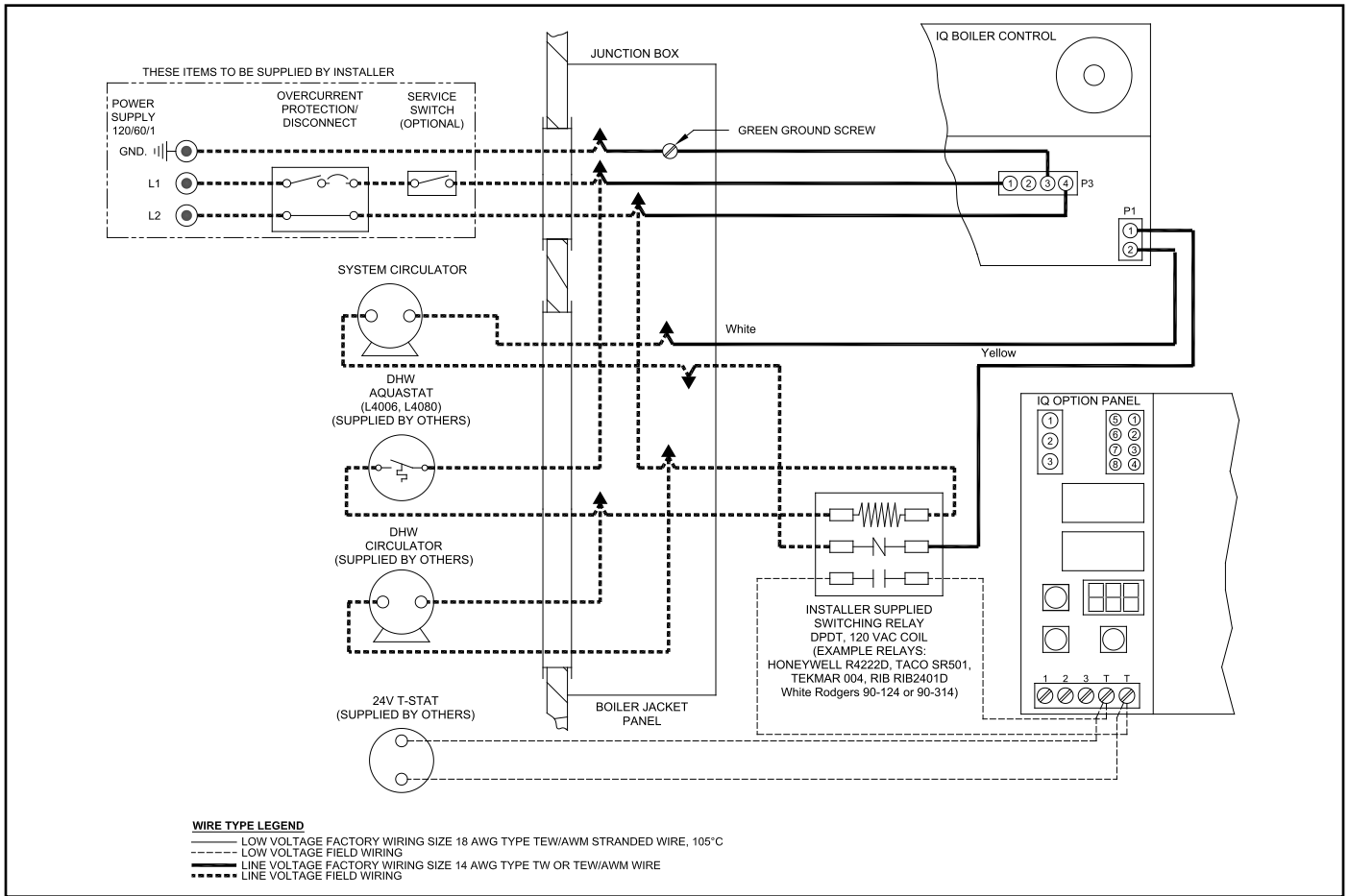

Figure IW-3: Single Zone System with Domestic Hot Water Tank

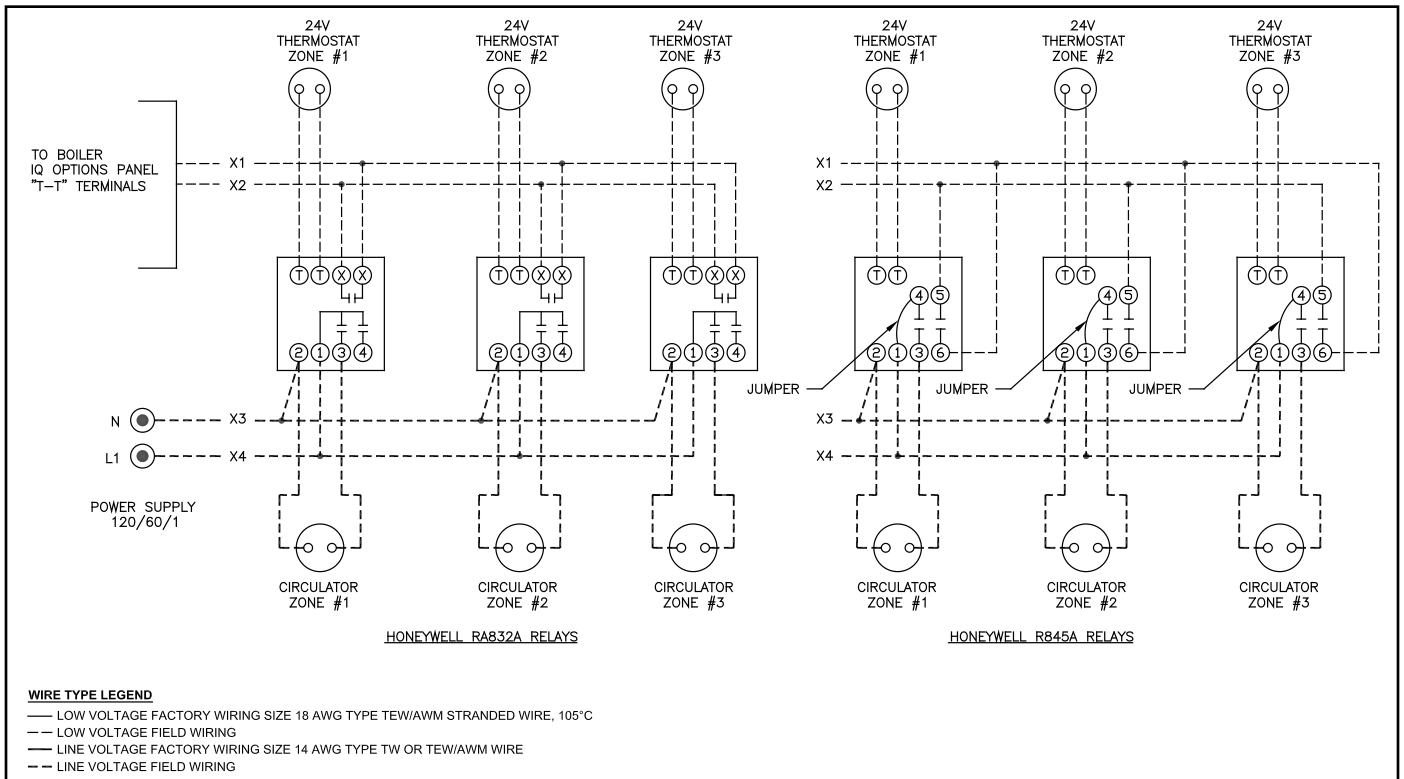

Figure IW-4: Multiple Zone System with Zone Circulators

INTERNAL WIRING (continued)

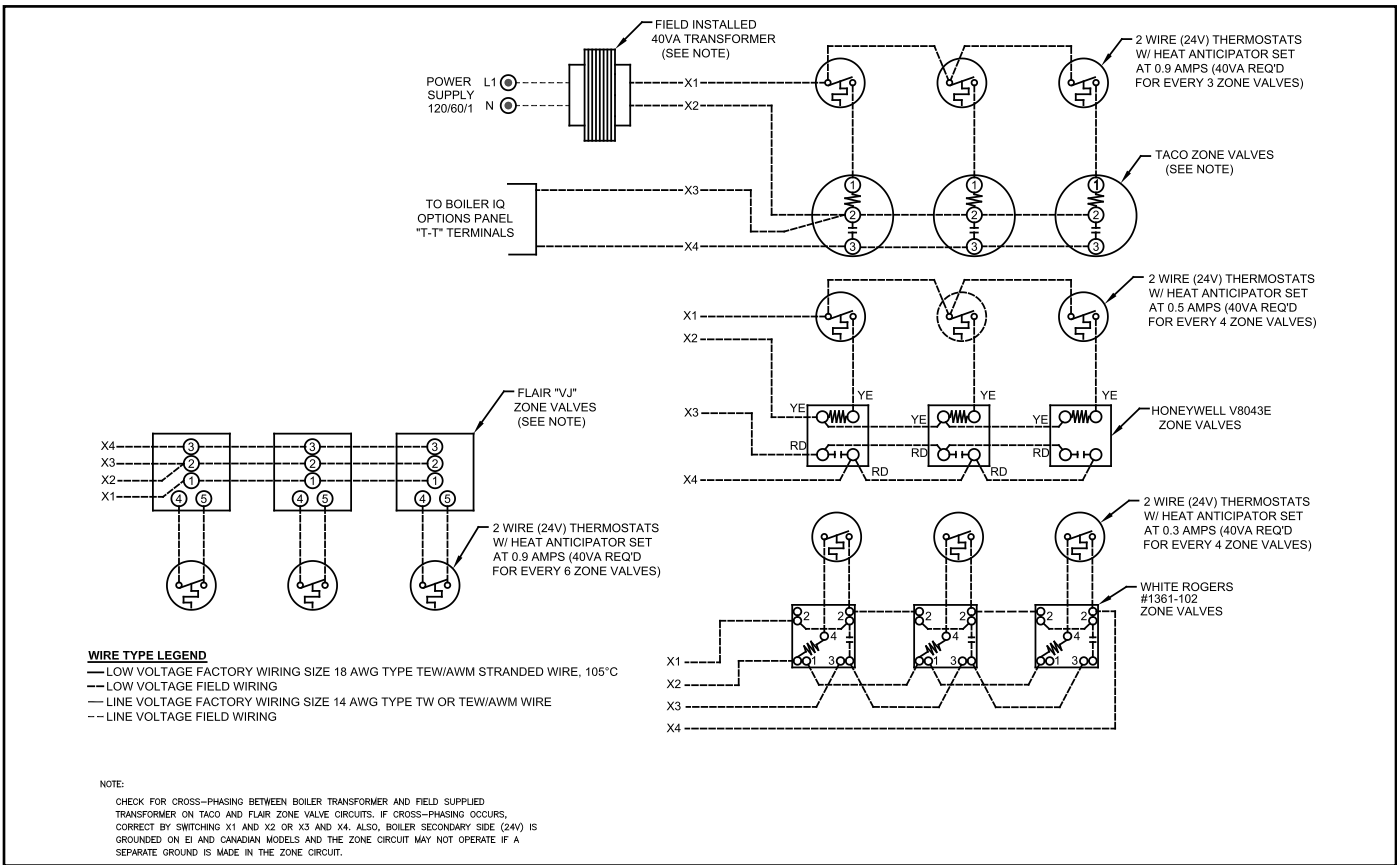

Figure IW-5: Multiple Zone System with Zone Valves

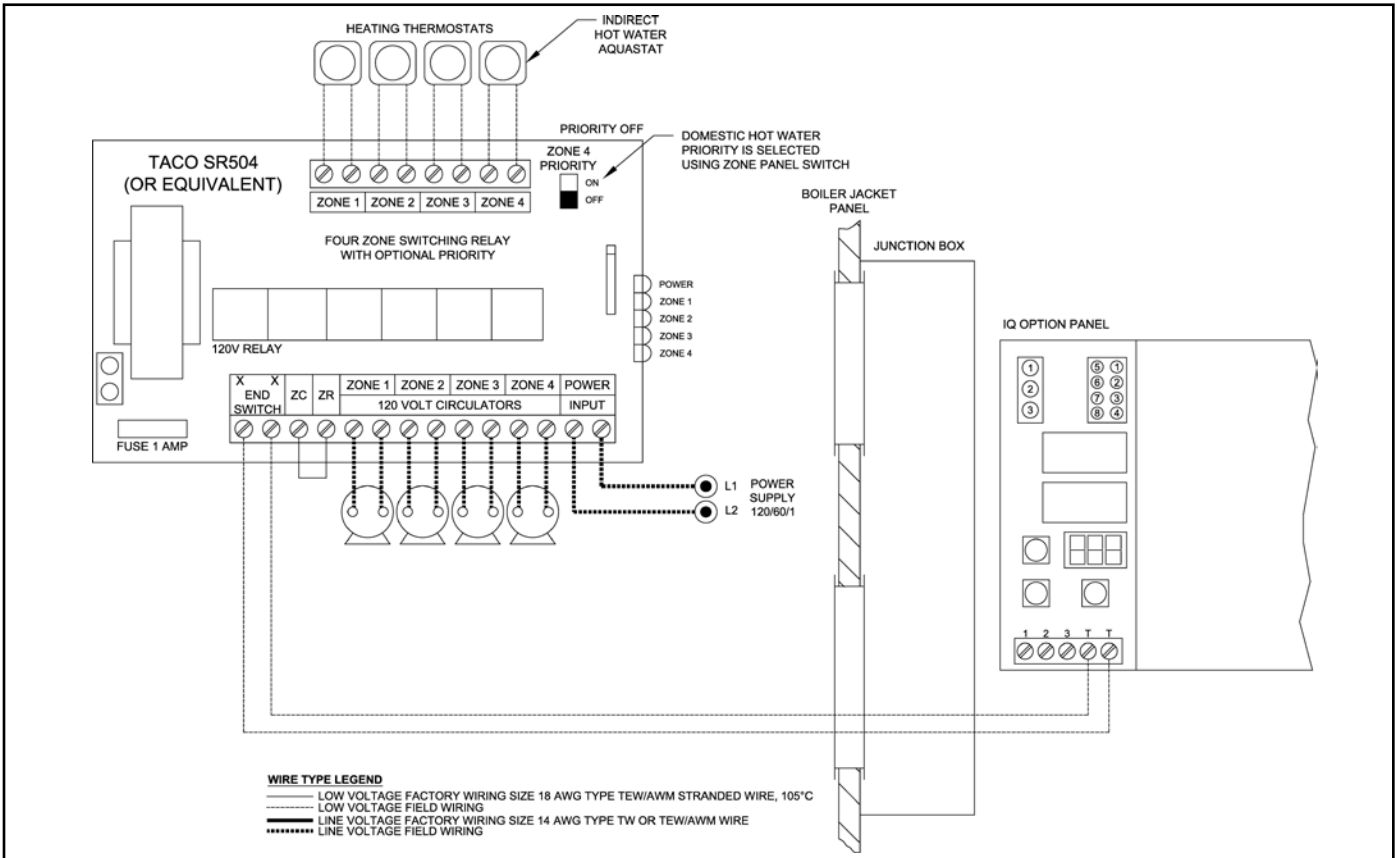

Figure IW-6: Multiple Zone System with Zone Circulator Panel

INTERNAL WIRING (continued)

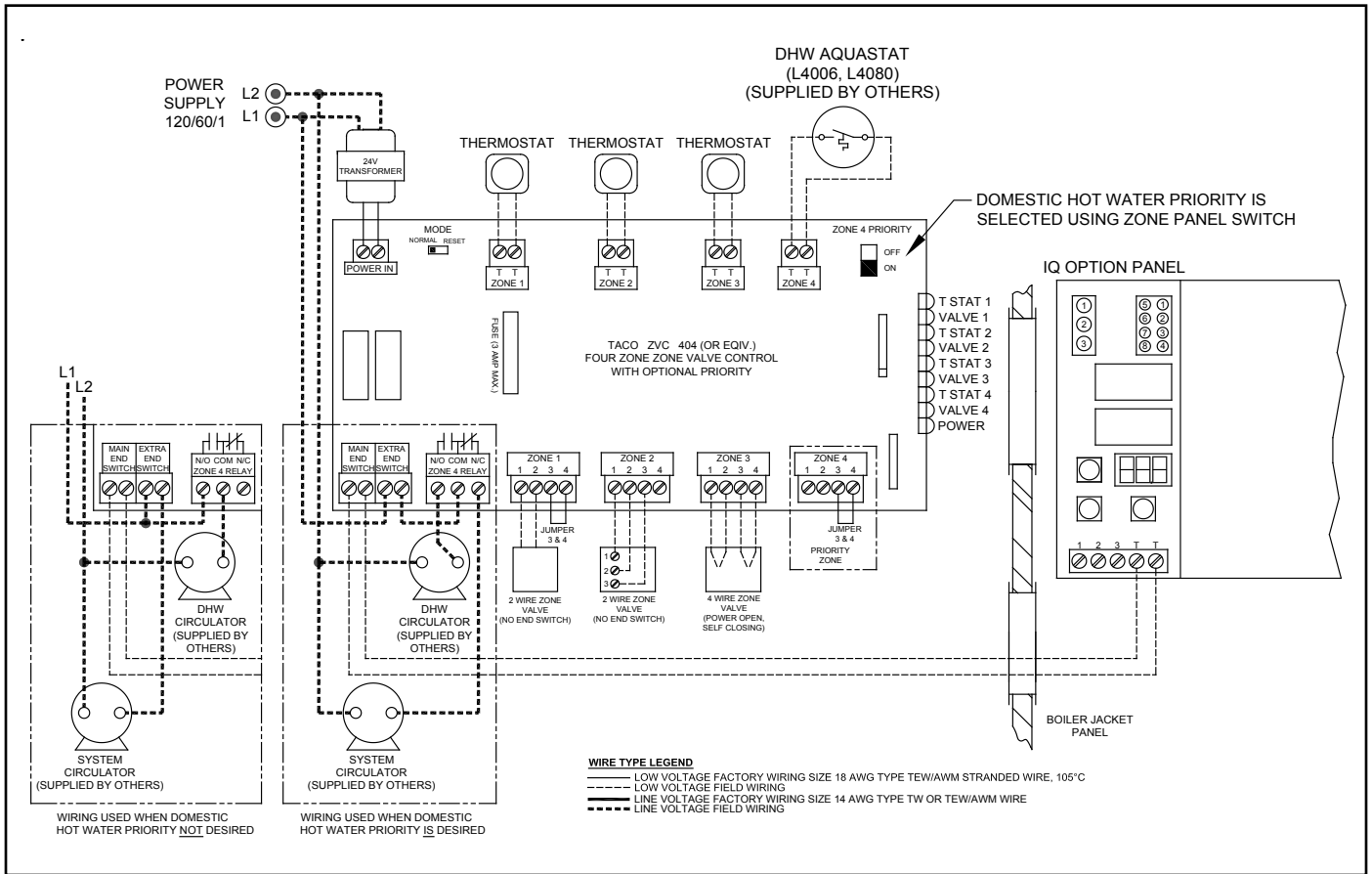

Figure IW-7: Multiple Zone System with Zone Valve Panel

APPENDIX A – COMBUSTION AIR



PROVIDE ENOUGH AIR to ventilate the boiler room, dilute the flue gases, and sustain combustion. Ignition failure, overheating, fire, carbon monoxide, and spillage of flue gases may result from poor air supply.

If the boiler is a Direct Vent boiler and exchanges all combustion air and combustion products directly with the outdoors, there are no special requirements for providing combustion, ventilation, and dilution air.

If the boiler is chimney vented, power vented or induced draft and draws combustion air from within the building, follow the steps below to determine how to provide air to the boiler.

Is the boiler located in a confined space?:

1. Calculate the floorspace (in square feet) of the boiler room and all rooms connected to the boiler room by passageways not furnished with doors.

_____ floorspace (sq. ft.)

2. Add up the input rates of all the combustion appliances installed in the same floorspace.

_____ combined appliance
input (BTU/hr)

3. In the table below, find the Minimum Allowable Floorspace based on the Combined Input Rate from Step 2 and the ceiling height. If the Combined Input Rate is between two rates, use the next highest rate.

_____ minimum allowable
floorspace (sq. ft.)

Minimum Allowable Floorspace in the Boiler Room and Freely Connected Rooms (sq. ft.)

		Ceiling Height			
		7'	8'	9'	10'
Combined Appliance Input Rate (see Step 2) (BTU/hr)	50,000	357	313	278	250
	100,000	714	625	556	500
	150,000	1071	938	833	750
	200,000	1429	1250	1111	1000
	250,000	1786	1563	1389	1250
	300,000	2143	1875	1667	1500
	350,000	2500	2188	1944	1750
	400,000	2857	2500	2222	2000

4. If the Floorspace from Step 1 is *less than* the Minimum Floorspace from Step 3, then you must provide outdoor air to the boiler room. Proceed to Step 6.

Is the boiler located in a building of unusually tight construction?

5. If the answer to *all* of the three questions below is “yes”, then you must provide outdoor air to the boiler room.

Do the walls and ceilings exposed to the outside atmosphere have a continuous water vapor retarder with a rating of 1 perm or less, with openings gasket or sealed?

Yes No

Are operable windows and doors weatherstripped?

Yes No

Are exterior wall joints caulked or sealed?

Yes No

6. If you must provide outdoor air to the boiler room, the top of the permanent opening into the boiler room must be within 12” of the ceiling, and the free area of the opening (sq. in.) must be no less than the Combined Appliance Input (from Step 2) divided by 3000 BTU/hr/sq. in.

_____ combined appliance
input (Step 2)

÷ _____ 3000 BTU/hr/sq. in.

_____ Minimum Opening Size
(sq. in.)

7. Duct this opening vertically or horizontally directly to the outdoors, or directly to a space that communicates directly with the outdoors, such as an attic or crawlspace.

For more details and options, refer to your local building code, the *National Fuel Gas Code (NFPA 54 and ANSI Z223)*, and the *Canadian Natural Gas Installation Code CAN/CGA-B149.1 or Propane Installation Code CAN/CGA-B149.2*.

APPENDIX B – VENTING



VENT THIS BOILER according to the instructions. Failure to do so may cause products of combustion to enter the building resulting in severe property damage, personal injury or death.



Install this boiler according to this manual and the National Fuel Gas Code, ANSI Z223.1/NFPA 54, the Natural Gas and Propane Installation Code, CAN/CSA B149.1, or applicable provisions of the local building codes. Contact local building or fire officials about restrictions and installation inspection in your area. In addition to previously mentioned vent codes of the main general guidelines, atmospheric vented installations must also be in accordance with the Standard for Chimneys, Fireplaces, Vents and Solid Fuel Burning Appliances, ANSI/NFPA 211. For Canada installations, refer to the Natural Gas and LP Installation Code, CAN/CSA- B149.1.

1. Per ANSI Z223.1/NFPA 54 the vent terminal shall have a minimum clearance of 4 feet horizontally from, and in no case above or below, unless a 4 feet horizontal distance is maintained, from electric meters, gas meters, regulators and relief equipment for U.S. installations. Per B149.1 this minimum distance shall be 6 feet for Canadian installations.

2. IF AN EXISTING BOILER IS REMOVED
When an existing boiler is removed from a common venting system, the common venting system is likely to be too large for proper venting of the appliances remaining to it.

At the time of removal of an existing boiler, the following steps shall be followed with each appliance remaining connected to the common venting system placed in operation, while the other appliances remaining connected to the common venting system are not in operation:

- (1) Seal any unused openings in the common venting system.
- (2) Visually inspect the venting system for proper size and horizontal pitch and determine there is no blockage or restriction, leakage, corrosion, and other deficiencies which could cause an unsafe condition.
- (3) Insofar as is practical, close all building doors and windows and all doors between the space in which the appliances remaining connected to the common venting system are located and other spaces of the building. Turn on clothes dryers and any appliance

not connected to the common venting system. Turn on any exhaust fans, such as range-hoods and bathroom exhausts, so they will operate at maximum speed. Do not operate a summer exhaust fan. Close fireplace dampers.

- (4) Place in operation the appliance being inspected. Follow the Lighting (or Operating) Instructions. Adjust thermostat so appliance will operate continuously.
- (5) Test for spillage at the draft hood relief opening after 5 minutes of main burner operation. Use the flame of a match or candle, or smoke from a cigarette, cigar or pipe.
- (6) After it has been determined that each appliance remaining connected to the common venting system properly vents when tested as outlined above, return doors, windows, exhaust fans, fireplace dampers and any other gas burning appliance to their previous conditions of use.
- (7) Any improper operation of the common venting system should be corrected so the installation conforms with the *National Fuel Gas Code, ANSI Z223.1* and/or *CAN/CSA B149.1, Installation Codes*. When resizing any portion of the common venting system, the common venting system should be resized to approach the minimum size as determined using the *National Fuel Gas Code, ANSI Z223.1* and/or *CAN/CSA B149.1, Installation Codes*.
Au moment du retrait d'une chaudière existante, les mesures suivantes doivent

APPENDIX B – Venting (continued)

être prises pour chaque appareil toujours raccordé au système d'évacuation commun et qui fonctionne alors que d'autres appareils toujours raccordés au système d'évacuation ne fonctionnent pas:

- (1) Sceller toutes les ouvertures non utilisées du système d'évacuation.
- (2) Inspecter de façon visuelle le système d'évacuation pour déterminer la grosseur et l'inclinaison horizontale qui conviennent et s'assurer que le système est exempt d'obstruction, d'étranglement, de fuite, de corrosion et autres défaillances qui pourraient présenter des risques.
- (3) Dans la mesure du possible, fermer toutes les portes et les fenêtres du bâtiment et toutes les portes entre l'espace où les appareils toujours raccordés au système d'évacuation sont installés et les autres espaces du bâtiment. Mettre en marche les sècheuses, tous les appareils non raccordés au système d'évacuation commun et tous les ventilateurs d'extraction comme les hottes de cuisinière et les ventilateurs des salles de bain. S'assurer que ces ventilateurs fonctionnent à la vitesse maximale. Ne pas faire fonctionner les ventilateurs d'été. Fermer les registres des cheminées.
- (4) Mettre l'appareil inspecté en marche. Suivre les instructions d'allumage. Régler le thermostat de façon que l'appareil fonctionne de façon continue.
- (5) Faire fonctionner le brûleur principal pendant 5 min ensuite, déterminer si le coupe-tirage déborde à l'ouverture de décharge. Utiliser la flamme d'une allumette ou d'une chandelle ou la fumée d'une cigarette, d'un cigare ou d'une pipe.
- (6) Une fois qu'il a été déterminé, selon la méthode indiquée ci-dessus, que chaque appareil raccordé au système d'évacuation est mis à l'air libre de façon adéquate. Remettre les portes et les fenêtres, les ventilateurs, les registres de cheminées et les appareils au gaz à leur position originale.
- (7) Tout mauvais fonctionnement du système d'évacuation commun devrait être corrigé de façon que l'installation soit conforme au *National Fuel Gas Code*, ANSI Z223.1 et (ou) aux codes *d'installation* CAN/CSA-B149.1. Si la grosseur d'une section du système d'évacuation doit être modifiée, le système devrait être modifié pour respecter les valeurs minimales des tableaux pertinents de l'appendice F du *National Fuel Gas Code*, ANSI Z223.1 et (ou) des codes *d'installation* CAN/CSA-B149.1.

3. Horizontal portions of the venting system shall be supported to prevent sagging. Follow venting Manufacturer's instructions.

For Category I, II and IV boilers, have horizontal runs sloping upwards not less than 1/4 inch per foot (21 mm/m) from the boiler to the vent terminal.

Les sections horizontales doivent être supportées pour prévenir le fléchissement. Suivez les instructions de ventilation Manufacturer.

Les chaudières de catégories I, II et IV doivent présenter des tronçons horizontaux dont la pente montante est d'au moins 1/4 po par pied (21 mm/m) entre la chaudière et l'évent.

4. Damper must be in open position when appliance main burner(s) is operating.

Le registre doit être ouvert lorsque le brûleur principal de l'appareil fonctionne.

APPENDIX B1 – ATMOSPHERIC VENTING



GENERAL WARNINGS FOR ATMOSPHERIC VENTING SYSTEMS

USE ATMOSPHERIC VENTING only with boilers approved for atmospheric venting as noted in the *Specifications* Section of this manual.

INSPECT EXISTING CHIMNEY for obstructions and deterioration and repair or line the chimney prior to placing the boiler in service.

UNLINED MASONRY CONSTRUCTION is prohibited for use as a chimney.

FIREPLACES AND FAN-ASSISTED GAS APPLIANCES must not be vented into the same chimney space as this boiler.

DO NOT REDUCE THE DIAMETER of the vent connector between the boiler and the chimney. It must not be smaller than the outlet on the draft hood, damper, or vent reducer supplied with the boiler.

UNLISTED VENT DAMPERS AND OBSTRUCTIONS in the vent pipe are prohibited.

THE VENT DAMPER supplied with the boiler shall not be used to block the vent of any other appliance.

Install vent and vent connector (Figure B-1). Comply with all design and installation requirements in the *Connect Venting* Section of this manual, local code, and the *National Fuel Gas Code* or *Can/CSA B149.1*. Clay flue lined masonry chimneys do not meet the venting requirements for this appliance.

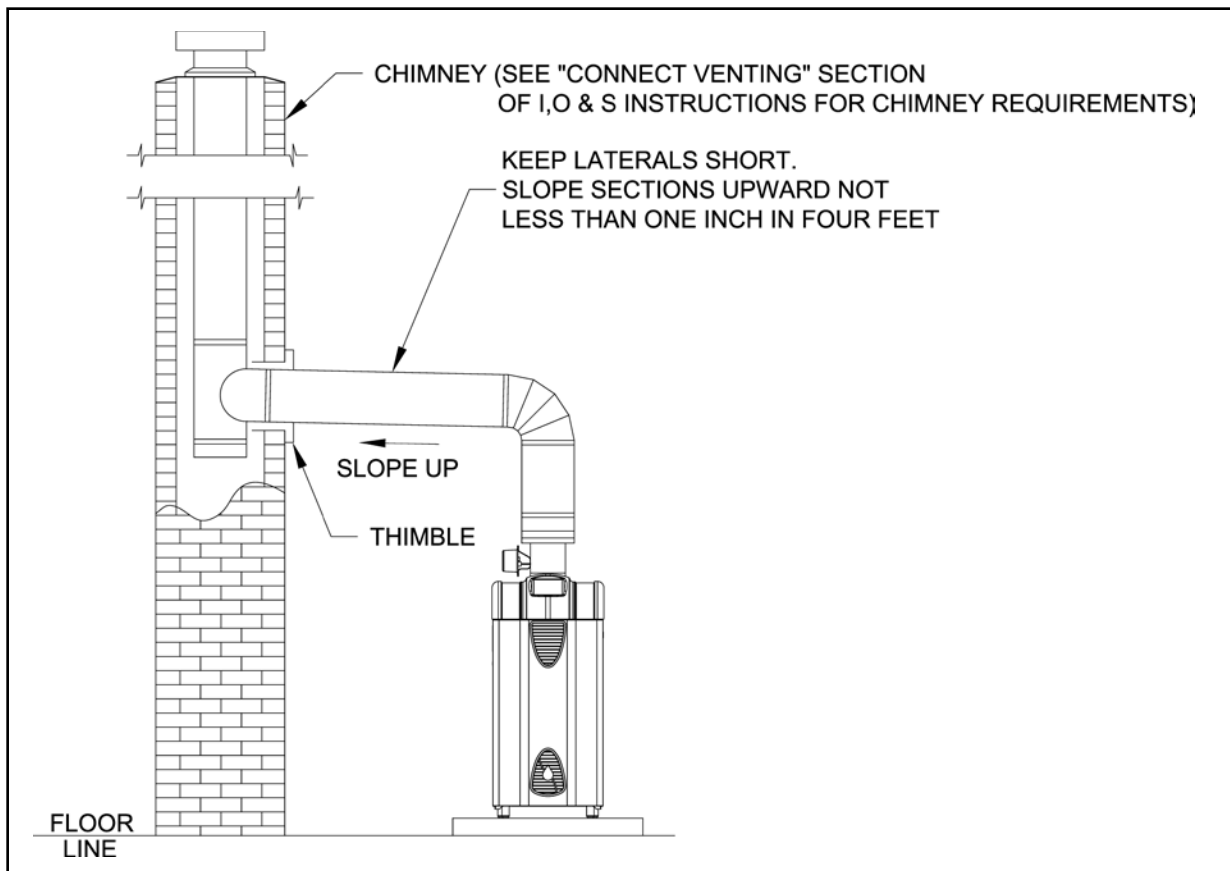

Figure B-1: Typical Atmospheric Vent Installation

APPENDIX C – GAS PIPING



ASSURE GAS PIPING IS LEAK FREE AND OF PROPER SIZE and type for the connected load.



SHUT OFF MAIN GAS SUPPLY prior to installing or servicing boiler gas piping.

1. Determine the boiler's maximum gas demand and minimum gas supply pressure (printed on the boiler's rating label) and the demand of other gas appliances served by the same gas meter.
2. Ensure that gas piping, fittings, and gas meter capacities can supply the maximum gas demand of all appliances at pressures above their minimum allowable gas pressure. Tables C-1 and C-2 provide typical capacities of gas pipes and fittings.
3. Derate the gas flow through pipes by multiplying by a correction factor in Table C-3 based on the specific gravity of the gas.
4. For materials or conditions other than those listed above, refer to the National Fuel Gas

Table C-3: Specific Gravity Correction Factors For Natural Gas

Specific Gravity	Correction Factor	Specific Gravity	Correction Factor
0.50	1.10	0.85	0.81
0.55	1.04	0.90	0.82
0.60	1.00	1.00	0.78
0.65	0.96	1.10	0.74
0.70	0.93	1.20	0.71
0.75	0.90	1.30	0.68
0.80	0.87	1.40	0.66

Code, NFPA54/ANSI Z223.1, or size the system using standard engineering methods acceptable to authority having jurisdiction.



USE PROPER THREAD COMPONENTS on all gas connectors.



USE THREAD (JOINT) COMPOUNDS (pipe dope) rated for liquefied petroleum gas.

Table C-1: Maximum Capacity of Schedule 40 Pipe in Cubic Feet Per Hour (CFH)*

Length (Feet)	0.3" w.c. Pressure Drop				0.5" w.c. Pressure Drop			
	½	¾	1	1¼	½	¾	1	1¼
10	132	278	520	1050	175	360	680	1400
20	92	190	350	730	120	250	465	950
30	73	152	285	590	97	200	375	770
40	63	130	245	500	82	170	320	660
50	56	115	215	440	73	151	285	580
60	50	105	195	400	66	138	260	530
70	46	96	180	370	61	125	240	490
80	43	90	170	350	57	118	220	460
90	40	84	160	320	53	110	205	430
100	38	79	150	305	50	103	195	400

*1 CFH of Natural Gas is approximately equal to 1000 BTU/hr; 1 CFH of LP is approximately equal to 2500 BTU/hr.

Table C-2: Equivalent Lengths (ft) Of Standard Pipe Fittings & Valves

Pipe Size	Gate	Globe	Angle	Swing Check	90° Elbow	45° Elbow	90° 'T', Flow Through Run	90° 'T', Flow Through Branch
½"	0	19	9	4	2	1	1	3
¾"	0	23	12	5	2	1	1	4
1"	1	29	15	7	3	1	2	5
1 ¼"	1	39	20	9	4	2	2	7
1 ½"	1	45	22	11	5	3	3	8

APPENDIX C – Gas Piping (continued)

5. Bond all above-ground gas piping to a grounding electrode and ensure the piping is electrically continuous.

 DO NOT USE GAS PIPING AS A GROUNDING ELECTRODE. Refer to National Electrical Code, NFPA 70.

6. Install sediment trap, ground-joint union and manual shut-off valve upstream of boiler gas control valve and outside jacket.
7. When the piping is completed, test it for leaks.
 - (1) When testing over ½ psig, disconnect the boiler and its individual shut-off valve from the gas supply piping.

- (2) When testing at ½ psig or less, isolate boiler from gas supply piping by closing boiler's individual manual shut-off valve.
- (3) Locate leaks using approved combustible gas detector or nonflammable, non-corrosive leak detection solution.

 DO NOT CHECK FOR LEAKS USING OPEN FLAMES such as matches or candles or devices that spark.

8. Repair any detected leaks.

APPENDIX D – SYSTEM PIPING

 USE PROPER DESIGN AND INSTALLATION PRACTICES and observe all local codes when installing system piping. Property damage and injury may result from an improperly piped or designed heating system.

 *Boiler damage caused by flawed system design or operation is excluded from our warranty.*

Training and experience is required to design and install a piping system that will protect the boiler and provide many years of comfort to the building occupants. Be sure to protect the boiler from the following problems:

1. Corrosion
 - (1) Comply with the boiler's specific water quality requirements. See the *Specifications* Section of this manual.
 - (2) Pressurize the system above the highest net positive suction head (NPSH) required for each circulator and ensure positive pressure at the uppermost point in the system.
 - (3) Maintain a closed boiler system using heat exchangers to transfer heat to open systems, such as domestic hot water systems.
 - (4) Purge the system completely of dissolved oxygen by bleeding all radiators and installing a properly installed air scoop or air vent.
 - (5) Repair leaking pipes, fittings, and vents to minimize the need to add makeup water.
 - (6) Do not fill the boiler with softened water unless makeup water is extremely hard and it is not possible to eliminate all system leaks. If filling the boiler with softened water, test regularly the water softener regularly to ensure that brine solution is not entering the boiler's water supply.
2. Lime scale
 - (1) Repair leaking pipes, fittings, and vents to minimize the need to add makeup water.

APPENDIX D – System Piping (continued)

(2) Comply with the boiler’s specific water quality requirements. See the *Specifications* Section of this manual.

(3) Comply with the boiler’s specific requirements for minimum water flow through the boiler, installing a system bypass or primary-secondary loop if necessary to maintain flow through the boiler when serving small zones.

3. Overpressure

- (1) Install a properly sized expansion tank.
- (2) Do not exceed the boiler’s specific requirements for maximum allowable working pressure.
- (3) Do not plug or block the relief valve.

4. Freezing

- (1) Run all portions of the system piping inside a heated space unless the system is properly protected with an inhibited antifreeze solution.

5. Overheating

- (1) Comply with the boiler’s specific requirement for minimum water flow through the boiler. See the *Specifications* Section of this manual.
- (2) Install a low-water cutoff device whenever the boiler is installed above the level of the lowest heat emitter

or radiator. Also add a low-water cutoff when required by local code requirements.

6. Thermal shock

- (1) Do not over-pump. Adhere to the design flow requirements for each zone.
- (2) Install a boiler bypass, system bypass, or primary-secondary loop when needed to avoid returning large volumes of cold water directly to a hot boiler.

7. Condensation

- (1) Do not over-pump. Adhere to the design flow requirements for each zone.
- (2) Adhere to the boiler’s specific minimum return water and supply water temperature requirements. Install a boiler bypass, system bypass, or primary-secondary loop when needed to maintain water temperatures and flows within the specified limits.
- (3) Do not allow chilled water to enter the boiler during the heating cycle, or heated water to enter chilled water coils during the cooling cycle.

8. Dry Fire

Install a low-water cutoff when the boiler is installed above the level of the lowest radiator and when required by local code.



The following system diagrams are intended to provide a minimum level of guidance for a successful and trouble-free installation of the boiler in common applications. They do not substitute for proper design, evaluation, and installation by a trained and qualified installer using the proper tools, techniques, and design expertise. Not all options are available with every boiler.

Hot Water Boilers, Non-Condensing

		Indirect Tank?	Two or more zones of the same temperature?	Two or more zones of different temperatures?	Two or more boilers?
See Diagram	D-W1				
	D-W2		✓		
	D-W3	Tankless Coil			
	D-W4	✓	✓		
	D-W5	✓	✓	✓	
	D-W6	✓	✓		✓

APPENDIX D – System Piping (continued)

























	Boiler		Motor Operated Mixing Valve Control		Temperature Sensor or Limit
	Indirect Water Heater		Zone Valve		Low Water Cut Off
	Tankless Coil with Temperature Sensor In Well		Full Port Ball Valve		3-Way Mixing Valve
	High Temperature Heating Panel		Isolation Valve		Pressure Reducing Valve
	Low Temperature Radiant Heating Panel		Flow Control Valve		Pressure Relief Valve
			Purge Valve		Air Scoop
			Drain Valve		Air Vent
			Circulator		Expansion Tank
			Pipe Union		
<u>Line Types</u>					
	Hot Water or Steam Supply Piping				
	Cold Water or Condensate Return Piping				
	Appliance Internal, Factory Supplied Piping				

Figure D-0: Piping Schematic Symbols

APPENDIX D – System Piping (continued)

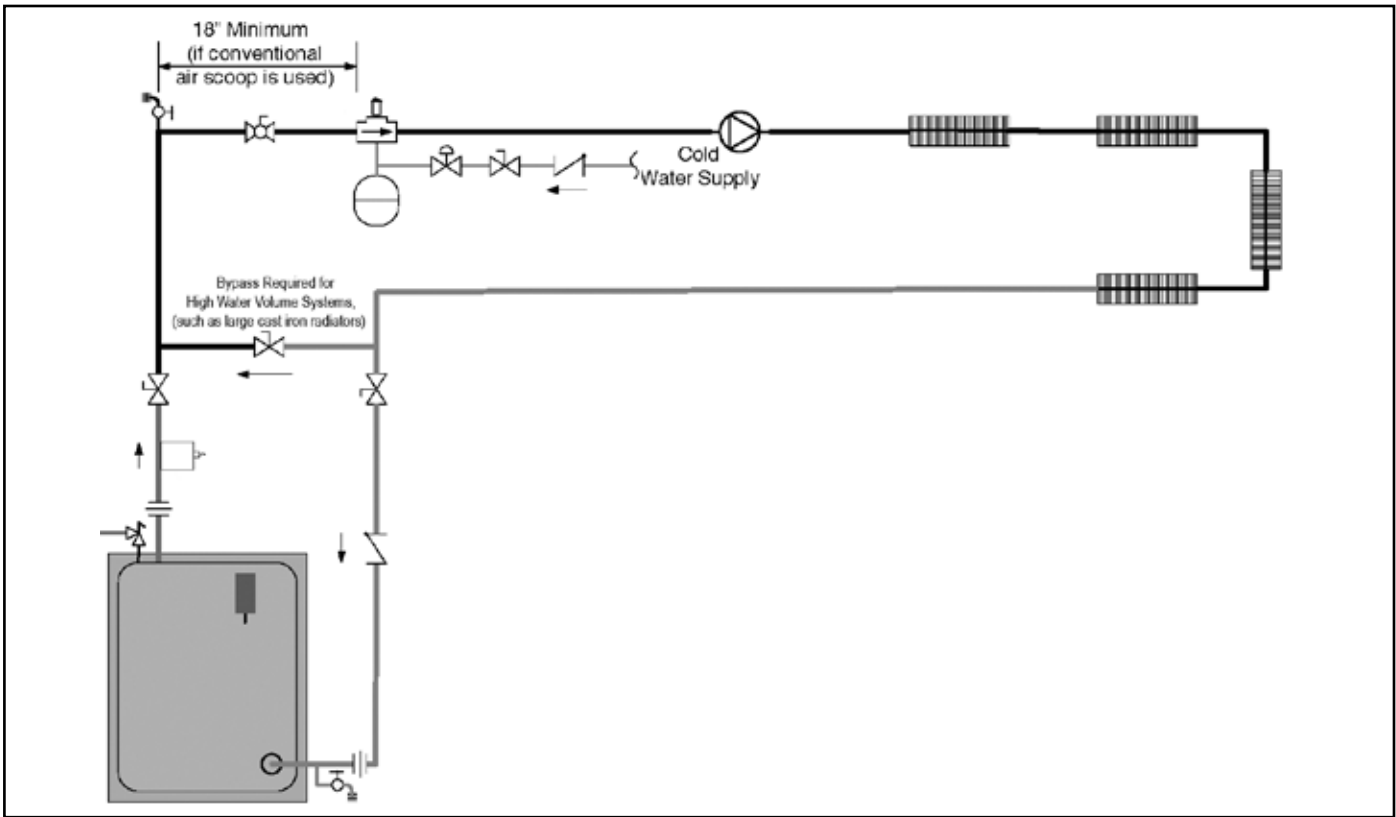

Figure D-W1: Water Boiler, Series Loop

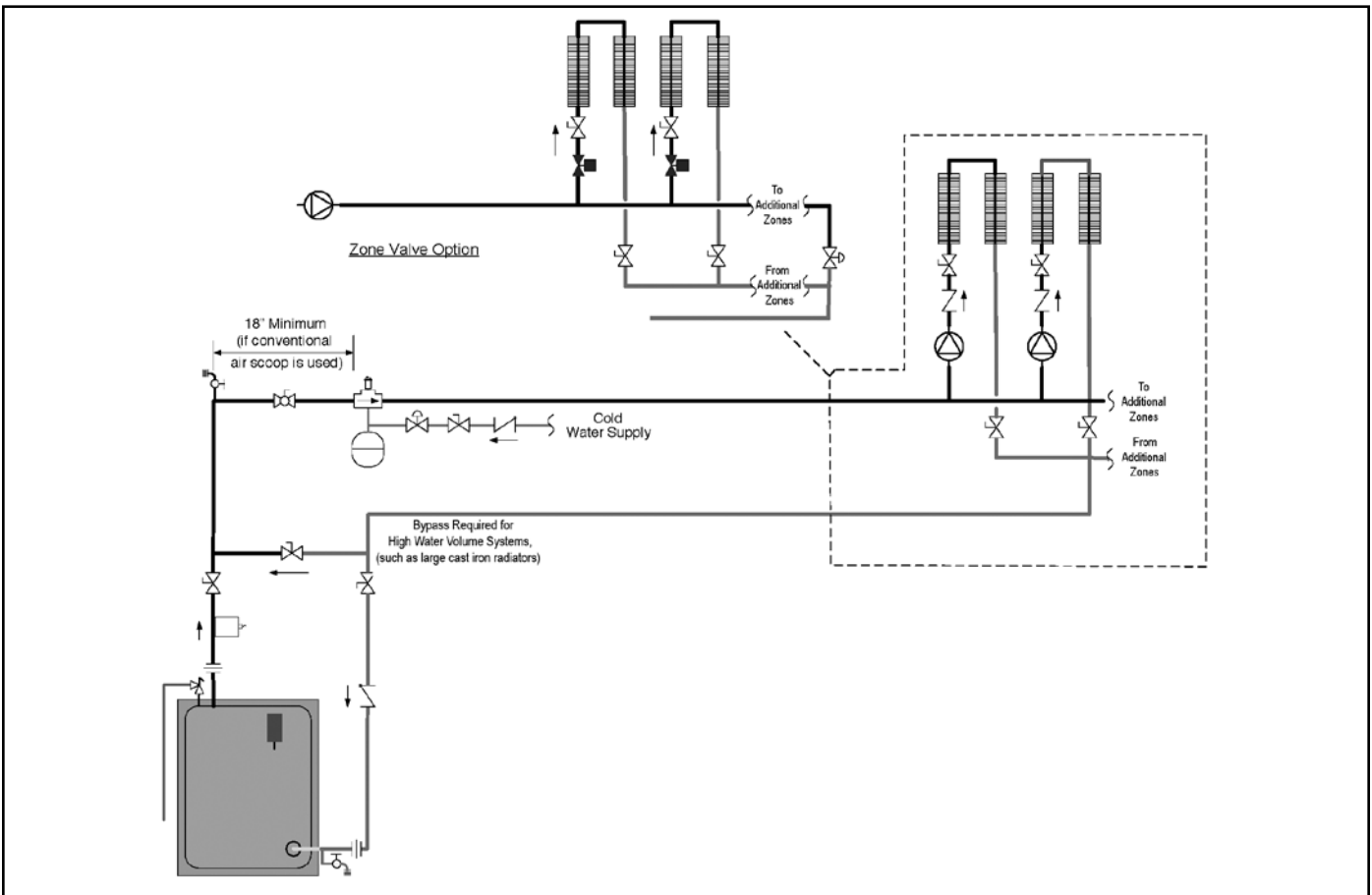

Figure D-W2: Water Boiler, Two or More Zones

APPENDIX D – System Piping (continued)

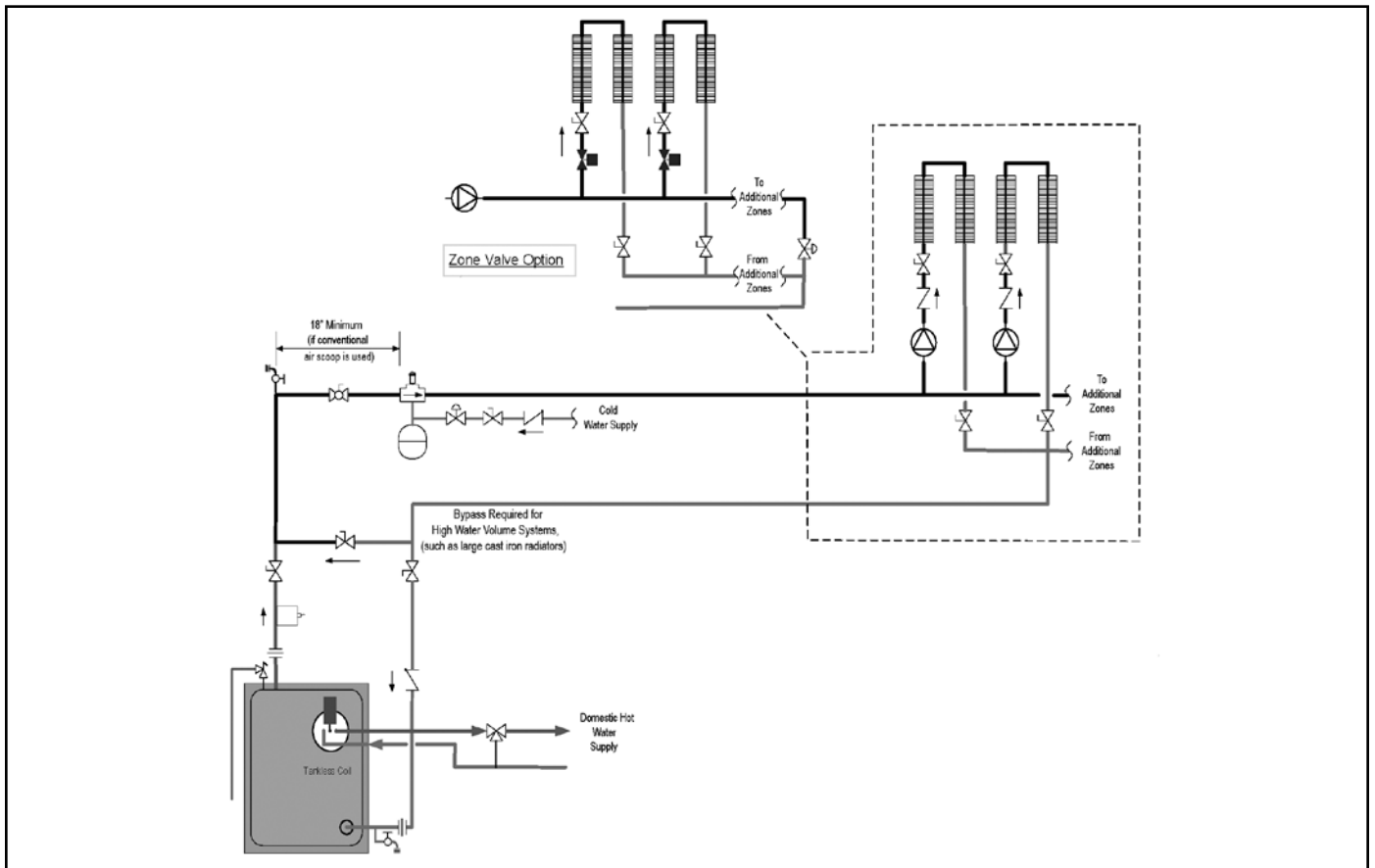

Figure D-W3: Water Boiler, Tankless Coil, Two or More Zones

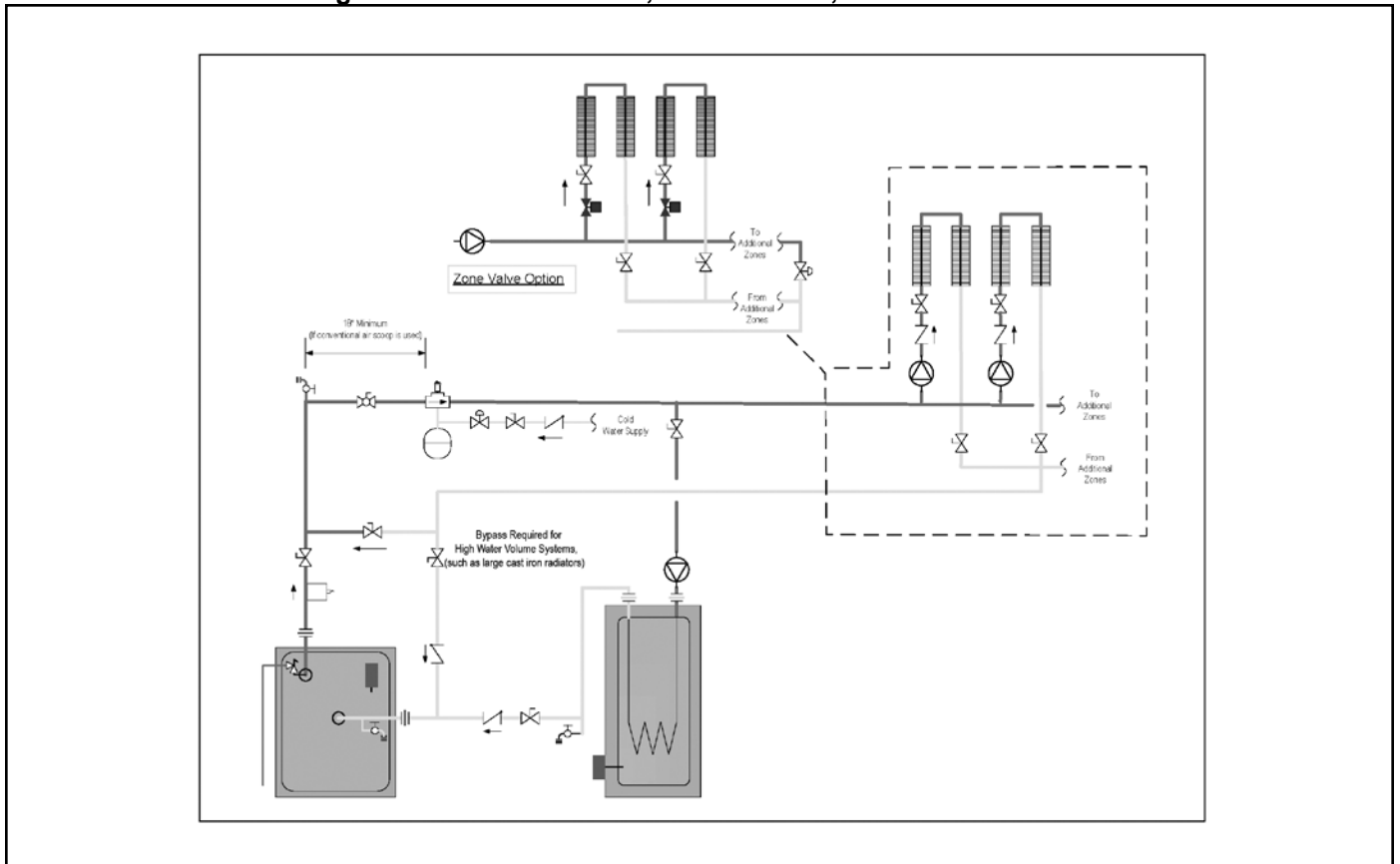

Figure D-W4: Water Boiler, Indirect Water Heater, Two or More Zones

APPENDIX D – System Piping (continued)

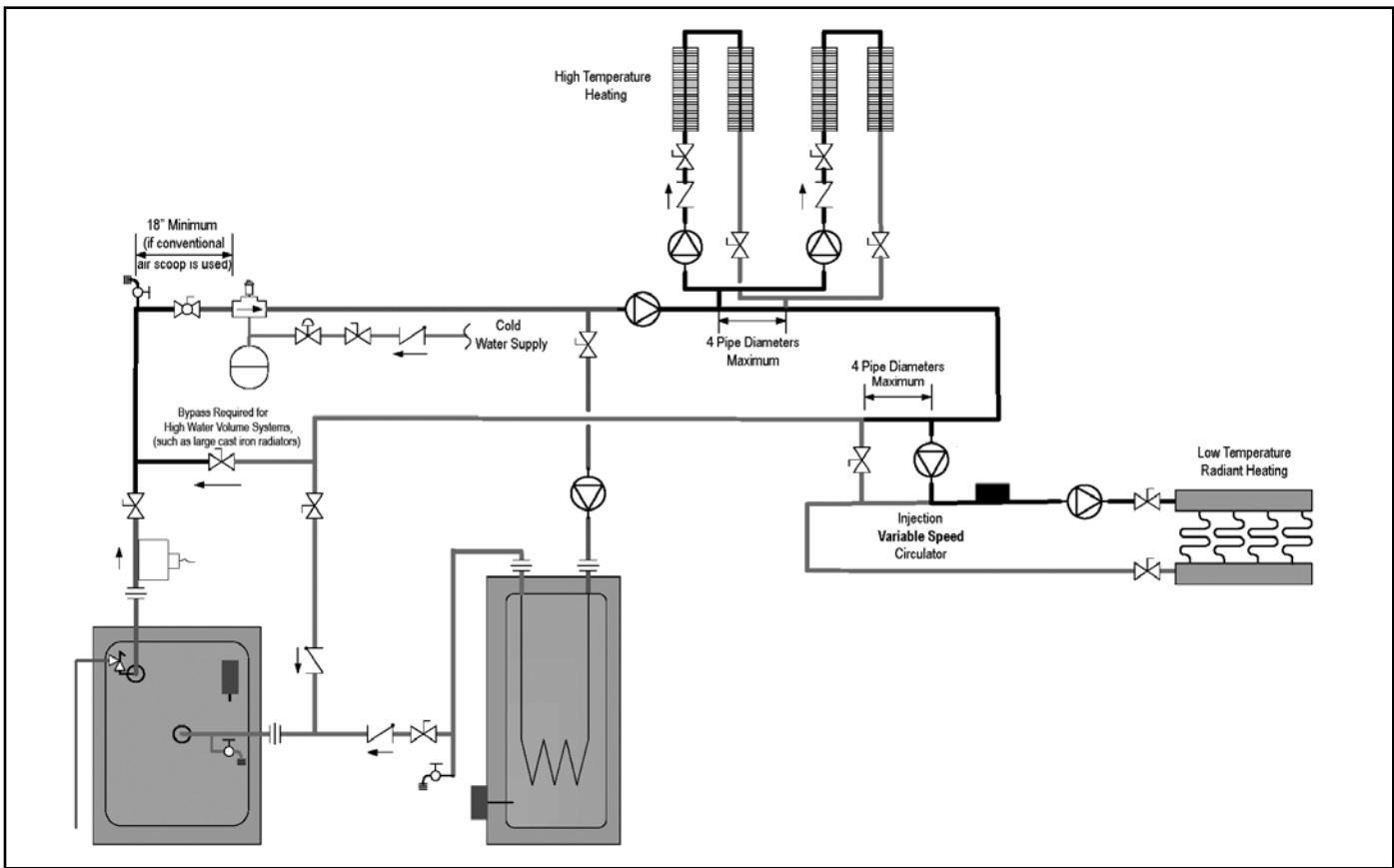

Figure D-W5: Water Boiler, Indirect Water Heater

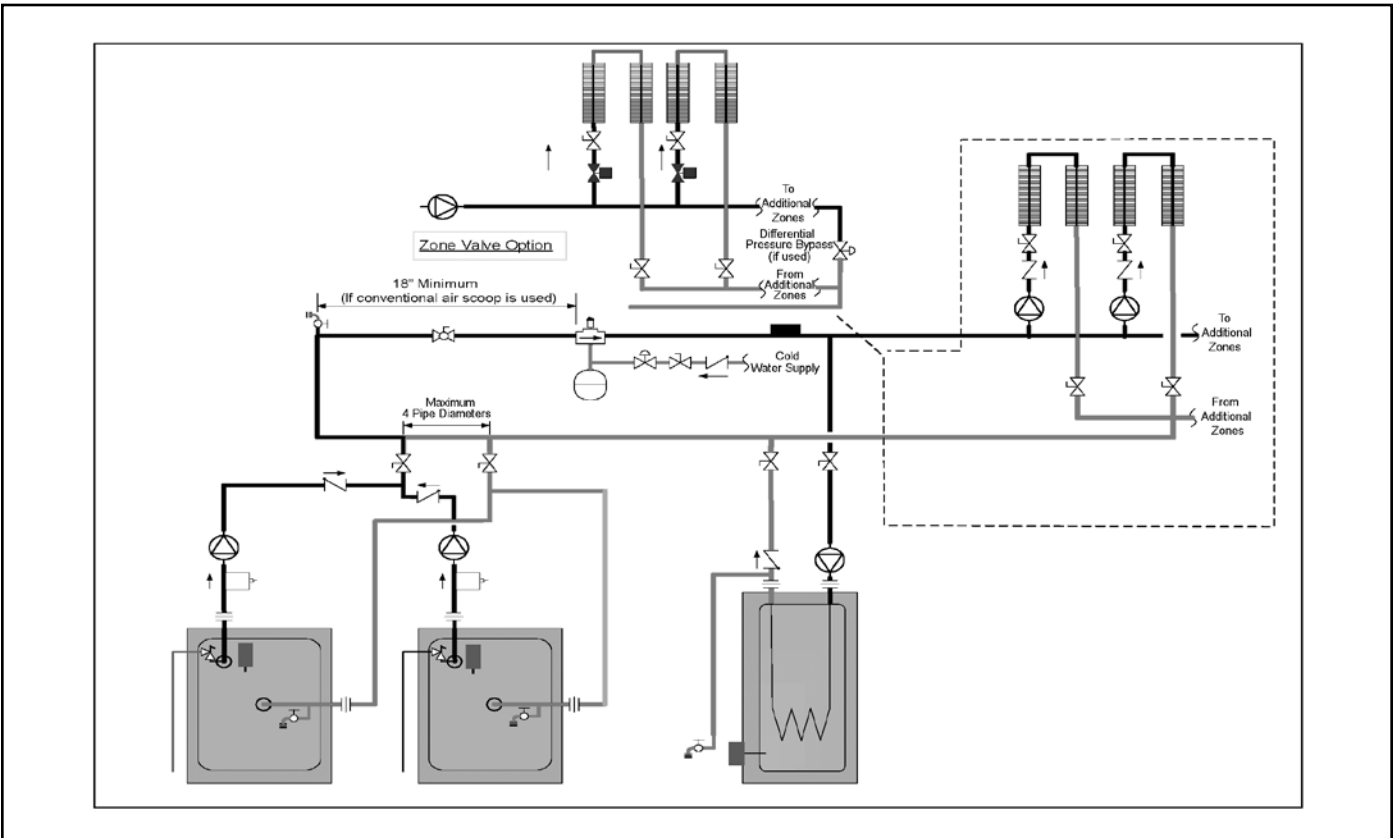

Figure D-W6: Multiple Water Boilers, Indirect Water Heater, Two or More Zones

APPENDIX E – FILLING THE SYSTEM AND CHECKING FOR LEAKS

Fill entire heating system with water and vent air from system. Use the following procedure on a Series Loop or multi-zoned system installed as per the figure below. Remove air from system when filling.

1. Close full port ball valve located between vertical hose bib and air scoop in boiler supply piping (see *Appendix D – System Piping*).
2. Isolate all zones by closing zone valves or shut-off valves in supply and return of each zone(s).
3. Attach a hose to the vertical hose bib located prior to the full port ball valve in the system supply piping.

i

Terminate hose in five-gallon bucket at a suitable floor drain or outdoor area.

4. Starting with one circuit at a time, open zone valve or shut-off valve in system supply and return piping.
5. Open hose bib.
6. Open fill valve (Make-up water line should be located directly after full port ball valve in system supply piping between air scoop and expansion tank).
7. Allow water to overflow from bucket until discharge from hose is bubble free for 30 seconds.
8. Close hose bib, continue filling the system until the pressure gauge reads 12 psi. Close fill valve.
9. Starting with the first convactor in the loop, open air vent to purge air until a steady stream of water flows into container for approximately 5 seconds. Proceed to next convactor and repeat procedure until all convectors in the loop are purged of air.
10. Close the opened zone valve or shut-off valve for the zone being purged of air.

11. Open the zone valve or shut-off valve for the next zone to be purged. Repeat the previous steps until all zones have been purged. At completion, open all zone valves or shut-off valves.
12. Close hose bib, continue filling the system until the pressure gauge reads 12 psi. Close fill valve.

i

If make-up water line is equipped with pressure reducing valve, system will automatically fill to 12 psi. Follow fill valve manufacturer's instructions.

13. Open isolation valve in boiler supply piping.
14. Remove hose from hose bib.

Confirm that the boiler and system have no water leaks.

1. Check Rating Label for maximum operating pressure of this boiler. Never exceed this pressure during leak test. Do not plug or change pressure relief valve. Perform visual inspection for leaks or weeping joints after initial fill and during boiler warm-up period. Repair all leaks before placing boiler into permanent operation.
2. If it is required to perform a long-term pressure leak test of the hydronic system, the boiler should first be isolated to avoid a pressure loss due to the escape of air trapped in the boiler.
3. To perform a long-term pressure test including the boiler, all trapped air must be removed from the boiler and system as prescribed above. A loss of pressure during such a test, with no visible leakage, is an indication that the boiler or system contained trapped air.

APPENDIX F – ADJUSTING GAS INPUT RATE

Natural Gas Boilers:

1. Turn off gas supply to all appliances other than gas-fired boiler.
2. Note the rated manifold gas pressure listed on the boiler's rating label.
3. Connect Manometer to manifold pressure tapping on Gas Valve (Figure F-1).

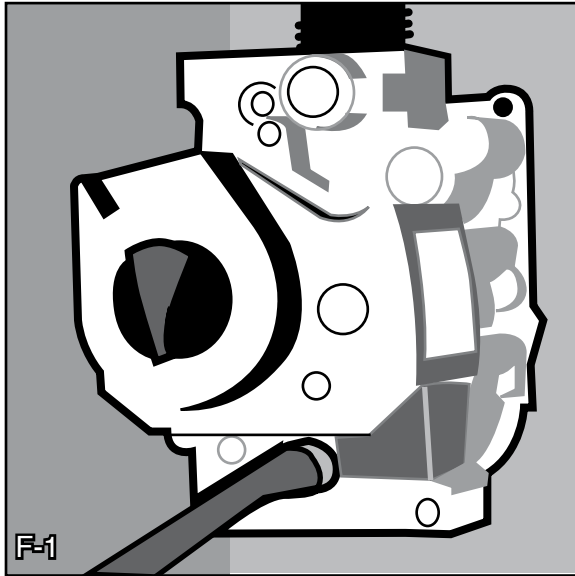

4. Light main burners by adjusting thermostat to highest setting.
5. If required, adjust gas manifold pressure to the rated setting by turning the gas valves adjustment screw clockwise to decrease manifold pressure or counterclockwise to increase manifold pressure (Figure F-2). Several turns may be required.



Do not force the adjustment screw.

6. On models using more than one gas valve, turn "off" the gas valve not having pilot control and first adjust the gas valve with pilot control. Then, turn "on" both gas valves and adjust the gas valve without pilot control.
7. Clock gas meter for at least two (2) revolutions of the dial typically labeled $\frac{1}{2}$ or 1 cubic foot per revolution on a residential gas meter.

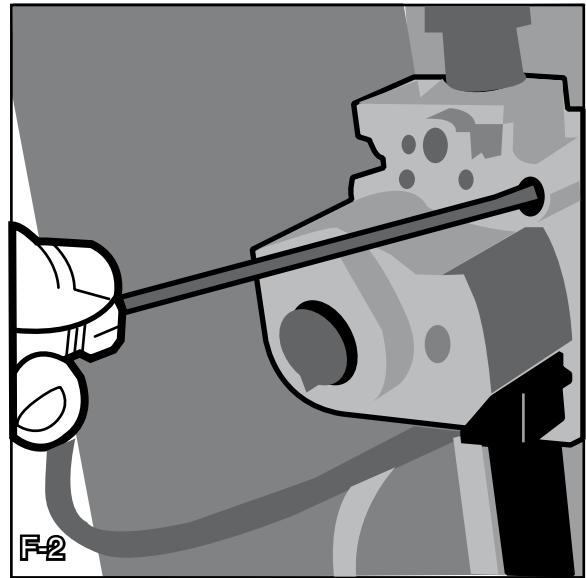

8. Determine gas flow rate in Cubic Feet per Hour based on elapsed time for two revolutions. (Example: 70 Seconds for (2) Revolutions = 102.8 Cu. Ft.
9. When the clocked time falls between two table values (Table F-1), add the table values shown above and below your clocked reading and divide by 2 (Example: 68 Seconds for (2) Revolutions = $(110.7+102.8) / 2 = 106.7$ Cu. Ft./Hr.).
10. Obtain gas-heating value (Btu per cubic foot) from gas supplier or use nominal value of 1000 Btu per cubic foot.
11. Multiply gas flow rate by gas heating value. (Example: 70 Seconds for (2) Revolutions = 120.8 Cu. Ft./Hr. X 1027 Btu/Cu. Ft. = 124,061 Btu/ Hr.
12. Compare measured input rate to input rate stated on rating label.



DO NOT EXCEED the boiler's rated gas input.

13. If input is too high, reduce input rate by decreasing manifold pressure. Do not reduce more than 0.3" w.c. Instead, contact Burnham for an orifice replacement kit.
14. If input is below 98% of Rating Label input, increase manifold gas pressure no more than 0.3 inches w.c. If measured rate is still less than 98% of rated input, replace or re-drill existing main burner gas orifices:

APPENDIX F – Adjusting Gas Input Rate (continued)

Table F-1: Gas Flow Rate in Cu. Ft. / Hr.

Seconds for Two (2) Revolutions	Size of Gas Meter Dial		
	One-Half Cu. Ft.	One Cu. Ft.	Two Cu. Ft.
24	150.0	300.0	450.0
26	138.4	276.9	415.3
28	128.5	257.1	385.7
30	120.0	240.0	360.0
34	105.8	211.7	317.6
38	94.7	189.4	284.2
42	85.7	171.4	257.1
46	78.2	156.5	234.7
50	72.0	144.0	216.0
55	65.4	130.9	196.3
60	60.0	120.0	180.0
65	55.3	110.7	166.1
70	51.4	102.8	154.2
80	45.0	90.0	135.0
90	40.0	80.0	120.0
100	36.0	72.0	108.0
120	30.0	60.0	90.0
140	25.7	51.4	77.1
160	22.5	47.0	67.5
180	20.0	40.0	60.0
200	18.0	36.0	54.0

- (1) Remove Main Burners per procedure in Boiler Service instructions in Section (X).
- (2) Remove gas orifices. Drill each orifice one (1) drill size larger (drill size is stamped on orifice).
- (3) Reinstall gas orifices and main burner. Repeat procedure to measure input rate.

15. Recheck Main Burner Flame.
16. Return other gas-fired appliances to previous condition of use.

LP/Propane Gas Boilers:

1. Follow the procedure for gas boilers, except:
2. Adjust tank regulator for gas valve inlet pressure of 13.5 inches w.c. or less, but not less than 11.5 inches w.c.
3. Gas valve has step-opening regulator, which initially opens to 1.4 to 2.5 inches w.c. and steps to full pressure after approximately 30 seconds. Check manifold pressure after step has occurred.

Leak Test Gas Piping:



THE BOILER AND ITS GAS CONNECTIONS must be leak tested and leak free before placing boiler in operation.



FOR LEAK TESTING OVER ½ PSIG, disconnect boiler and its individual shut-off valve from gas supply piping.

1. For testing at ½ psig or less, isolate boiler from gas supply piping by closing boiler's individual manual shut-off valve.
2. Check for gas leaks in all piping joints, valves, and fittings using a non-corrosive leak detection solution or an electronic leak detector.
3. Repair any leaks.

APPENDIX G – CHECKING DRAFT AND COMBUSTION

CHECK DRAFT (GAS BOILERS WITH DRAFT HOODS)

1. Insofar as is practical, close all doors and windows in the building.
2. Turn on all appliances not connected to the same venting system as the boiler being checked.
3. Turn on all exhaust fans (such as range hoods and bathroom exhausts) to their maximum speed. Do not turn on any summer exhaust fans.
4. Close all fireplace dampers.
5. Operate the appliance being checked. Follow lighting instructions.
6. After 5 minutes of main burner operation, test for spillage at the draft hood relief opening, using a lighted match, candle, cigarette, etc.
7. Repeat this test for each appliance connected to the common venting system.
8. If any appliance does not vent properly, per the above test, make corrections, so that the installation conforms to the *National Fuel Gas Code, NFPA 54/ANSI Z223.1*, and/or *Installation Codes, CAN/CSA B149.1*.
9. Return doors, windows, exhaust fans, fireplace dampers, and any other gas-burning appliance to their previous condition of use.

CHECK DRAFT (OIL BOILERS)

1. Use a manometer precise to 0.01" water column.
2. Fire the boiler until the chimney/vent reaches normal operating temperature.
3. Locate the pressure sensing tapping on the boiler.
4. While the boiler is still firing, use the manometer to measure the draft at the pressure tapping.
5. Confirm that the draft measurement matches the required draft specified for the boiler.
6. If the required draft is not present, make any necessary adjustments and check again.

CHECK COMBUSTION

1. Use a flue gas analyzer that accurately measures CO₂, O₂, CO, and flue gas temperature.
2. For oil boilers, also use a smoke tester with smoke test paper.
3. Operate the boiler at its rated (high fire) input.
4. With the analyzer, check the CO₂ (or O₂), CO and temperature of the flue gases exiting the boiler.
5. For two-stage or modulating boilers, also check the CO₂ (or O₂), CO and temperature of the flue gases at low fire.
6. Confirm that the measured CO₂ (or O₂) matches the required CO₂ (or O₂) specified for the boiler.
7. For oil boilers, also take a smoke measurement of the flue gases. Smoke should not exceed #1.



If CO₂, O₂, or CO fall outside of the range specified for the boiler, review the installation and startup instructions and make any necessary adjustments to the boiler or associated venting or piping systems.



Note the gross flue gas temperature for future reference. Significant changes in flue gas temperature can indicate changes in the boiler's operating efficiency.

APPENDIX H – IQ CONTROL SYSTEM

IQ Control System Overview

The “IQ Control System” consists of an IQ Boiler Control and an IQ Option Panel with optional “plug in” cards:

- Fully integrates both factory and field installed components, simplifying installation and troubleshooting.
- Efficiently operates the entire boiler system to save energy.

- Ensures adequate heat and supply of domestic hot water.
- UL / CSA Listed or Recognized and tested as part of a complete system.
- Communicate with other EnviraCom™ enabled components to provide a complete system solution to maximize comfort and energy efficiency.

IQ Boiler Control:

The heart of Burnham’s IQ Control System is the IQ Boiler Control. The IQ Boiler Control replaces the traditional separate ignition control, primary boiler aquastat, as well as the fan and circulator relays.



When the optional Outdoor Air Reset Card is installed in the IQ Option Panel, the Operating Setpoint temperature is automatically adjusted according to the outdoor temperature. For example, as the outdoor temperature increases the Operating Setpoint temperature is reduced from the High Limit Setting to save energy while improving home comfort. By better matching boiler heat supply to actual home heat demand, room air temperatures are more closely maintained. In addition, when there is a domestic hot water (DWH) heat request, the Operating Setpoint temperature is automatically adjusted to a DWH Setpoint to satisfy the DWH heating requirements. When the Outdoor Air Reset Card is not installed the Operating Setpoint equals High Limit Setting.

The IQ Boiler Control stores two boiler supply temperature setpoints in its memory; one setpoint is for the High Limit Setting and the second is for the Operating Setpoint.

IQ Option Panel:

The IQ Option Panel works together with the IQ Boiler Control to provide an easy and convenient means to “plug-in” additional functionality to a boiler system.

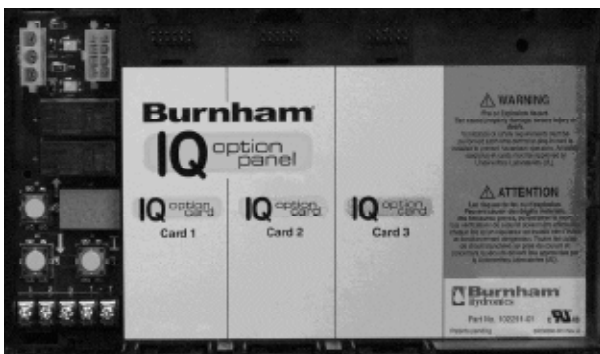

The IQ Option Panel is a standard component provided along with the IQ Boiler Control. The IQ Option Panel functions as a “motherboard” to accept up to three (3) IQ Option Cards and provides the necessary mechanical connections (with no screws required), along with the power and interconnection wiring into the IQ Boiler System. Only wiring from field-installed sensors is required. The IQ Option Panel includes a dedicated digital readout that provides option card status information, diagnostics and setup functions when necessary.

APPENDIX H – IQ Control System (continued)

IQ Option Cards:



A variety of IQ Option Cards are available to enhance the features of a standard boiler.

For example, if additional safety limits are required, select Manual or Automatic Reset Aquastat or Low Water Cutoff IQ Option Cards. Additionally, if energy savings and improved home comfort is desired, select an Outdoor Reset IQ Option Card.

Outdoor Reset IQ Option Card:

The Outdoor Reset IQ Option Card regulates hydronic heating system heat delivery rate to match the home heat demand and building heat loss. This is accomplished by continuously adjusting the boiler supply water temperature setpoint based on outside air temperature, domestic hot water demand and “sleep” or “leave” period selections, when a Honeywell EnviraCOM enabled programmable thermostat is connected.

Refer to the Outdoor Reset IQ Option Card instructions for additional information.

Benefits of the Outdoor Reset Card: Increased comfort through smooth, continuous, regulated heat delivery and reduced indoor air temperature fluctuations.

Energy Savings through:

- (1) reducing room overheating
- (2) reducing boiler temperature and
- (3) increasing combustion efficiency

Aquastat IQ Option Card:

The Aquastat IQ Option Card provides electronic temperature sensing in a UL limit-rated control with a single sensing probe. The Aquastat IQ Option Card replaces auxiliary high limits such as the L4006.

The Aquastat IQ Option Cards are available in automatic or manual reset models. Automatic reset versions automatically reset when temperature return to safe levels. Manual reset

models require user intervention to reset a temperature condition after the temperature returns to safe levels.

Listings/Approvals:

- UL353 Limit Controls for both US (UL) and Canada (CUL)—Component Recognized
- UL 1998 Software Safety Standards as a Class 2 device.

Low Water Cutoff (LWCO) IQ Option Card:

The Low Water Cutoff (LWCO) IQ Option Cards are advanced devices that detect the absence of water in the boiler. LWCO IQ Option Cards use patented signal processing to identify when the probe signal levels have decreased due to fouling, permitting extended operation for probe impedances up to 40K Ohms. The LWCO IQ Option Cards function longer without requiring probe cleaning and can operate in the presence of foam.

Fully compliant with **CSD-1** requirements for water level controls.

The LWCO IQ Option Card is available with automatic and manual reset. Automatic reset

versions automatically reset when water levels return to safe levels. Manual reset models require user intervention to reset a low water condition after water levels return to safe levels. Manual reset models will not “lock out” upon power loss provided water still covers the probe when power returns.

Listings/Approvals:

- UL GUIDE (MBPR2) for Limit Controls per UL Standard 353 Limit Controls—Component
- UL GUIDE (MBPR8) Controls, Limit Certified for Canada—Component per CSA Standard C22.2

APPENDIX H – IQ Control System (continued)

IQ Display Kit:

The LCD Display is an easy to use touch screen type display that allows a technician to monitor and adjust the IQ Boiler Control and connected IQ Option Cards.

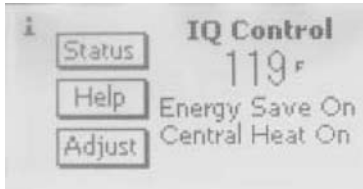

The LCD Display kit includes a mounting bracket and wiring harness to allow simple physical installation and “plug-in” style electrical connection. This intuitive display reduces setup and troubleshooting time by providing the user adjustment and alarm focused “help” and “information” screens.

EnviraCOM Thermostats:

Standard EnviraCOM thermostats provide “heat demand” to the IQ Boiler Control and alerts the home owner of a boiler control faults.



Connected thermostats provide a red LED and display the IQ Boiler Control or IQ Option Card Error Codes. A home owner is alerted to a problem even before the water is cold. When an Outdoor Reset card is installed, thermostat “leave” or “sleep” modes are used to shifts the reset curve to save energy while the home is in a reduced room temperature mode.

APPENDIX H – IQ Control System (continued)

System Parts List

Factory Mounted Components

Burnham Part Number	Item Description
102289-01	IQ Boiler Control , Vent Damper, 24 Vac Ignition Control, with Prepurge, Continuous Retry, 90 Second Ignition Trail, Aquastat Limit Control, 130-220 Deg F, 15 Deg F Adjustable Differential, Auto Reset, less Well, less Sensor, 120 Vac Circulator Control Relay
102291-01	IQ Option Panel with three slots “plug-in” option card slots, suitable for gas or oil fired boiler applications, accepts a variety of plug-in cards including limit rated cards
102411-01	Limit Rated Temperature Sensor, 24 inch length

Optional Components

Burnham Part Number	Item Description
102723-01	Outside Reset IQ Option Card, Domestic Hot Water Priority, for use with Option Control Panel, with Outside Air Temperature Sensor with 60 inch lead, Instructions, Unit Pack. No additional pipe fittings required.
102294-01	Outdoor Reset IQ Option Card, Domestic Hot Water Priority, for use with IQ Option Panel, less Sensor.
102946-01	Outdoor Air Temperature Sensor, 12k ohm, 60 inch lead.
102711-01	LWCO IQ Option Card kit, Hot Water LF Module, Automatic Reset, for use with Option Control Panel, with ¾ inch NPT Probe, Instructions, Unit Pack. Additional pipe fittings are required.
102714-01	LWCO IQ Option Card kit, Hot Water LF Module, Manual Reset, for use with Option Control Panel, with ¾ inch NPT Probe, Instructions, Unit Pack. Additional pipe fittings are required.
102301-01	LWCO IQ Option Card, Hot Water LF Module, Automatic Reset, for use with IQ Option Panel, less Probe.
102302-01	LWCO IQ Option Card, Hot Water LF Module, Manual Reset, for use with IQ Option Panel, less Probe.
102305-01	LWCO ¾ inch NPT Probe.
102720-01	Aquastat IQ Option Card, 130-220 Deg F, Manual Reset for use with Option Control Panel, Temperature Sensor with 36 inch lead, Well, Sensor Clip, Instructions, Unit Pack. Additional pipe fittings are required.
102717-01	Aquastat , IQ Option Card, 130-220 Deg F, 15 Deg F Adjustable Differential, Auto Reset, for use with Option Control Panel, Temperature Sensor with 36 inch lead, Well, Sensor Clip, Instructions, Unit Pack. Additional pipe fittings are required.
102292-01	Aquastat IQ Option Card, 130-220 Deg F, Manual Reset for use with IQ Option Panel, less well, Less Sensor.
102293-01	Aquastat , IQ Option Card, 130-220 Deg F, 15 Deg F Adjustable Differential, Auto Reset, for use with IQ Option Panel, less Well, less Sensor.
102295-01	Limit Rated Temperature Sensor, 36 inch length.
102296-01	Limit Rated Temperature Sensor, 48 inch length.
102728-01	IQ LCD Display , Boiler Exterior Mounted, STN Monochrome, White/Red backlight, 5Vdc Power Supply, RS422 (RS485) Communication, Pure Black Bezel with Gateway, Wire Harness, Mounting Bracket, Logo Plate and Instructions.
102725-01	IQ LCD Display , Boiler Exterior Mounted, STN Monochrome, White/Red backlight, 5Vdc Power Supply, RS422 (RS485) Communication, Pure Black Bezel.
102495-01	Enviracom/Modbus RS422 Gateway and 5 Vdc Power Supply for Communication Between the IQ Controls and LCD Display, 24 Vac Power Supply Input.

Additional Information List

Aquastat IQ Option Card Instruction Sheet - part number 102715-01

Outdoor Reset IQ Option Card Instruction Sheet - part number 102721-01

Low Water Cut-off IQ Option Card Instruction Sheet - part number 102709-01

LCD Display Kit - part number 102727-01

Limited Warranty

For Residential Grade Water and Steam Boilers Using Cast Iron, Carbon Steel, Cast Aluminum, or Stainless Steel Heat Exchangers and Parts/Accessories

Subject to the terms and conditions set forth below, U.S. Boiler Company, Inc. Lancaster, Pennsylvania hereby extends the following limited warranties to the original owner of a residential grade water or steam boiler or U.S. Boiler Company, Inc. supplied parts and/or accessories manufactured and shipped on or after July 1, 2008:

ONE YEAR LIMITED WARRANTY ON RESIDENTIAL GRADE BOILERS AND PARTS / ACCESSORIES SUPPLIED BY U.S. BOILER COMPANY, INC.

U.S. Boiler Company, Inc. warrants to the original owner that its residential grade water and steam boilers and parts/accessories comply at the time of manufacture with recognized hydronic industry standards and requirements then in effect and will be free of defects in material and workmanship under normal usage for a period of one year from the date of original installation. If any part of a residential grade boiler or any part or accessory provided by U.S. Boiler Company, Inc. is found to be defective in material or workmanship during this one year period, U.S. Boiler Company, Inc. will, at its option, repair or replace the defective part.

HEAT EXCHANGER WARRANTIES

U.S. Boiler Company, Inc. warrants to the original owner that the heat exchanger of its residential grade boilers will remain free from defects in material and workmanship under normal usage for time period specified in the chart below of the original owner at the original place of installation. If a claim is made under this warranty during the "No Charge" period from the date of original installation, U.S. Boiler Company, Inc. will, at its option, repair or replace the heat exchanger. If a claim is made under this warranty after the expiration of the "No Charge" period from the date of original installation, U.S. Boiler Company, Inc. will, at its option and upon payment of the pro-rated service charge set forth below, repair or replace the heat exchanger. The service charge applicable to a heat exchanger warranty claim is based upon the number of years the heat exchanger has been in service and will be determined as a percentage of the retail price of the heat exchanger model involved at the time the warranty claim is made as follows:

Years in Service	Service Charge as a % of Retail Price																																
	1-5	6	7	8	9	10	11	12	13	14	15	16	17	18	19	20	21	22	23	24	25+												
Cast Iron Water	No Charge					5	10	15	20	25	30	35	40	45	50	55	60	65	70	75													
Cast Iron Steam*	No Charge					100																											
Carbon Steel	No Charge					5	10	15	20	25	30	35	40	45	50	55	60	65	70	75													
Cast Aluminum	No Charge					30	40	50	60	70	100																						
Stainless Steel	No Charge					30	40	50	60	70	100																						

NOTE: If the heat exchanger involved is no longer available due to product obsolescence or redesign, the value used to establish the retail price will be the published price as shown in the Burnham® Products Repair Parts Pricing where the heat exchanger last appeared or the current retail price of the then nearest equivalent heat exchanger.

***Burnham® MegaSteam™ Waterside Corrosion Warranty:** U.S. Boiler Company, Inc. warrants the cast iron sections of the Burnham® MegaSteam™ boiler to resist Temperature Induced Chloride Activated Graphitic Corrosion for a period of five years from the date of original installation. In the event that any cast iron section of a Burnham® MegaSteam™ boiler fails due to this corrosion mechanism during this period, U.S. Boiler Company, Inc. will repair or replace, at its option, the cast iron section assembly.

LIFETIME NIPPLE LEAKAGE WARRANTY

U.S. Boiler Company, Inc. warrants the cast iron and steel nipples that join the cast iron boiler sections to be free of defects in material and workmanship for the lifetime of the original owner at the original place of installation. In the event that such nipples are found to be defective in material and workmanship during this period, U.S. Boiler Company, Inc. will repair or replace at its option, the cast iron section assembly.

ADDITIONAL TERMS AND CONDITIONS

1. Applicability: The limited warranties set forth above are extended only to the original owner at the original place of installation within the United States and Canada. These warranties are applicable only to boilers, parts, or accessories designated as residential grade by U.S. Boiler Company, Inc. and installed in a single or two-family residence and do not apply to commercial grade products.
2. Components Manufactured by Others: Upon expiration of the one year limited warranty on residential grade boilers, all boiler components manufactured by others but furnished by U.S. Boiler Company, Inc. (such as oil burner, circulator and controls) will be subject only to the manufacturer's warranty, if any.
3. Proper Installation: The warranties extended by U.S. Boiler Company, Inc. are conditioned upon the installation of the residential grade boiler, parts, and accessories in strict compliance with U.S. Boiler Company, Inc. installation instructions. U.S. Boiler Company, Inc. specifically disclaims liability of any kind caused by or relating to improper installation.
4. Proper Use and Maintenance: The warranties extended by U.S. Boiler Company, Inc. conditioned upon the use of the residential grade boiler, parts, and accessories for its intended purposes and its maintenance accordance with U.S. Boiler Company, Inc. recommendations and hydronics industry standards. For proper installation, use, and maintenance, see all applicable sections of the Installation and Operating, and Service Instructions Manual furnished with the unit.
5. This warranty does not cover the following:
 - a. Expenses for removal or reinstallation. The homeowner will be responsible for the cost of removing and reinstalling the alleged defective part or its replacement and all labor and material connected therewith, and transportation to and from U.S. Boiler Company, Inc.
 - b. Components that are part of the heating system but were not furnished by U.S. Boiler Company, Inc. as part of the residential boiler.
 - c. Improper burner adjustment, control settings, care or maintenance.

- d. This warranty cannot be considered as a guarantee of workmanship of an installer connected with the installation of the U.S. Boiler Company, Inc. boiler, or as imposing on U.S. Boiler Company, Inc. liability of any nature for unsatisfactory performance as a result of faulty workmanship in the installation, which liability is expressly disclaimed.
 - e. Boilers, parts, or accessories installed outside the 48 contiguous United States, the State of Alaska and Canada.
 - f. Damage to the boiler and/or property due to installation or operation of the boiler that is not in accordance with the boiler installation and operating instruction manual.
 - g. Any damage or failure of the boiler resulting from hard water or scale buildup in the heat exchanger.
 - h. Any damage caused by improper fuels, fuel additives or contaminated combustion air that may cause fireside corrosion and/or clogging of the burner or heat exchanger.
 - i. Any damage resulting from combustion air contaminated with particulate which cause clogging of the burner or combustion chamber including but not limited to sheetrock or plasterboard particles, dirt, and dust particulate.
 - j. Any damage, defects or malfunctions resulting from improper operation, maintenance, misuse, abuse, accident, negligence including but not limited to operation with insufficient water flow, improper water level, improper water chemistry, or damage from freezing.
 - k. Any damage caused by water side clogging due to dirty systems or corrosion products from the system.
 - l. Any damage resulting from natural disaster.
 - m. Damage or malfunction due to the lack of required maintenance outlined in the Installation and Operating Manual furnished with the unit.
6. Exclusive Remedy: U.S. Boiler Company, Inc. obligation for any breach of these warranties is limited to the repair or replacement of its parts in accordance with the terms and conditions of these warranties.
 7. Limitation of Damages: Under no circumstances shall U.S. Boiler Company, Inc. be liable for incidental, indirect, special or consequential damages of any kind whatsoever under these warranties, including, but not limited to, injury or damage to persons or property and damages for loss of use, inconvenience or loss of time. U.S. Boiler Company, Inc. liability under these warranties shall under no circumstances exceed the purchase price paid by the owner for the residential grade boiler involved. Some states do not allow the exclusion or limitation of incidental or consequential damages, so the above limitation or exclusion may not apply to you.
 8. Limitation of Warranties: These warranties set forth the entire obligation of U.S. Boiler Company, Inc. with respect to any defect in a residential grade boiler, parts, or accessories and U.S. Boiler Company, Inc. shall have no express obligations, responsibilities or liabilities of any kind whatsoever other than those set forth herein. These warranties are given in lieu of all other express warranties.

ALL APPLICABLE IMPLIED WARRANTIES, IF ANY, INCLUDING ANY WARRANTY OF MERCHANTABILITY OR FITNESS FOR A PARTICULAR PURPOSE ARE EXPRESSLY LIMITED IN DURATION TO A PERIOD OF ONE YEAR EXCEPT THAT IMPLIED WARRANTIES, IF ANY, APPLICABLE TO THE HEAT EXCHANGER IN A RESIDENTIAL GRADE BOILER SHALL EXTEND TO THE ORIGINAL OWNER FOR THE TIME SPECIFIED IN THE HEAT EXCHANGER SECTION SHOWN ABOVE AT THE ORIGINAL PLACE OF INSTALLATION. SOME STATES DO NOT ALLOW LIMITATION ON HOW LONG AN IMPLIED WARRANTY LASTS, SO THE ABOVE LIMITATION MAY NOT APPLY TO YOU.

PROCEDURE FOR OBTAINING WARRANTY SERVICE

In order to assure prompt warranty service, the owner is requested to complete and mail the Warranty Card provided with the product or register product online at www.usboiler.burnham.com within ten days after the installation of the boiler, although failure to comply with this request will not void the owner's rights under these warranties. Upon discovery of a condition believed to be related to a defect in material or workmanship covered by these warranties, the owner should notify the installer, who will in turn notify the distributor. If this action is not possible or does not produce a prompt response, the owner should write to U.S. Boiler Company, Inc., Attn: Customer Service, P.O. Box 3079, Lancaster, PA 17604, giving full particulars in support of the claim. The owner is required to make available for inspection by U.S. Boiler Company, Inc. or its representative the parts claimed to be defective and, if requested by U.S. Boiler Company, Inc. to ship these parts prepaid to U.S. Boiler Company, Inc. at the above address for inspection or repair. In addition, the owner agrees to make all reasonable efforts to settle any disagreement arising in connection with a claim before resorting to legal remedies in the courts.

THIS WARRANTY GIVES YOU SPECIFIC LEGAL RIGHTS AND YOU MAY ALSO HAVE OTHER RIGHTS WHICH VARY FROM STATE TO STATE.



U.S. Boiler Company, Inc., P.O. Box 3020, Lancaster, PA 17604