

# ПехИТ

## Exercise Bike Instruction Manual

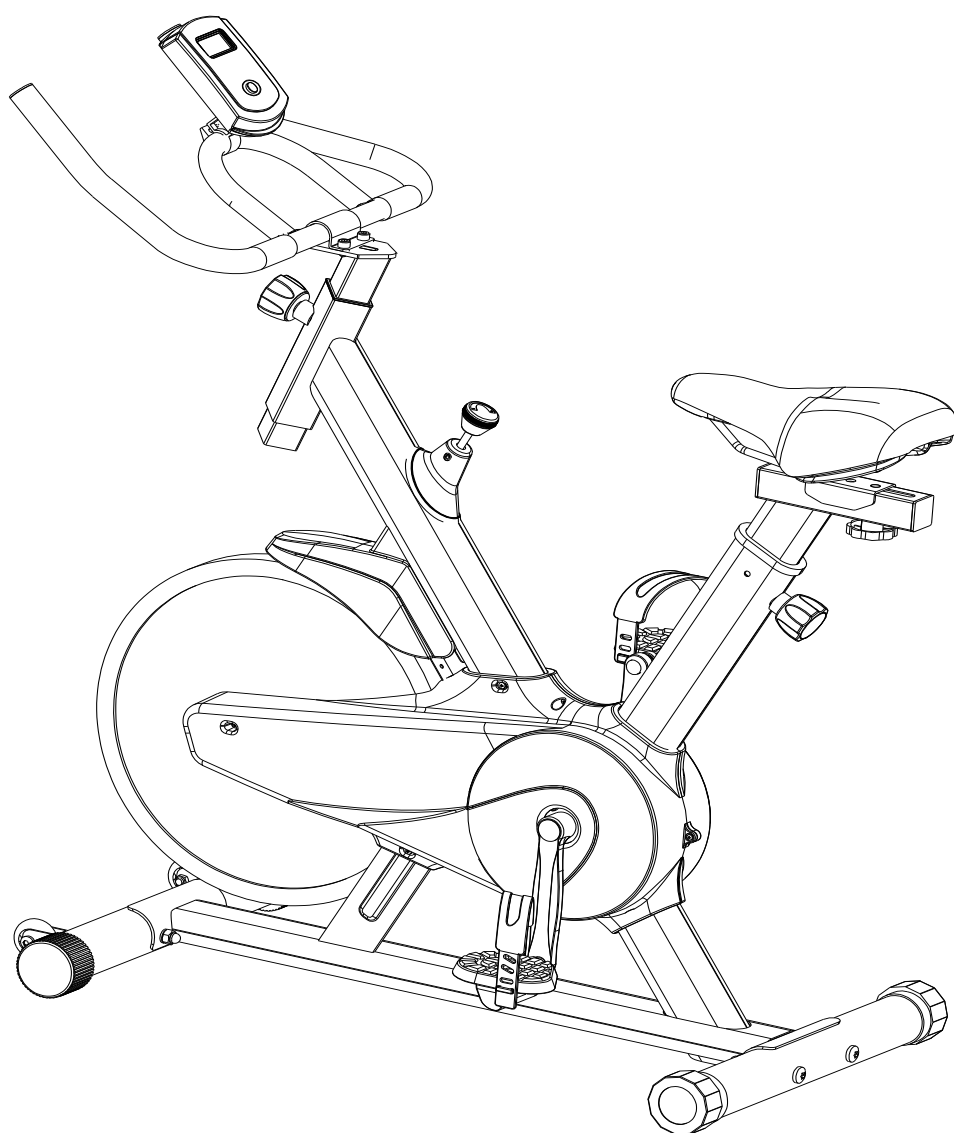

# Content

1. Warning-----	1
2. Spare Parts Diagram-----	2
3. Installation Instruction-----	4
4. LCD Monitor-----	7
5. Adjustment-----	8
6. Maintenance & Troubleshooting-----	10
7. Warm up-----	11
8. Package Contents-----	13
9. Warranty-----	13

## **1. Warning**

Before you use the bike, please read the instructions carefully to ensure that you receive the correct information of usage, including the free spare parts we provided for you.

- 1). This bike is for home use and not belong to commercial use, the max loading is 265LBS.
- 2). Please use it in strict accordance with the instruction.
- 3). Please carefully check the machine before first use and check it according to the principle of installation every 1 to 2 months. Please try to keep the machine in normal use and use the original accessories.
- 4). If it does not work well, please contact the dealer and agency.
- 5). Please keep the machine out of the corrosive cleaner.
- 6). Please use after the correct installation and careful inspection.
- 7). Please adjusted the parts to their maximum level before installation.
- 8). This product is for adults. If children want to use, please make sure they have a guardian with them.
- 9). Please don't do dangerous action and move on this product.
- 10). Please use this product under the guidance of doctors or fitness specialists, it will have very good effect.
- 11). Please make reasonable plans before using the product and use it in strict accordance with the requirements.
- 12). The resistance of this product is adjustable. Please select the appropriate

resistance.

13). Please carefully check all the bolts and screw parts to ensure your safety before use.

14). During exercise, make sure to put the feet into pedal covers. Do not stop immediately during fast rotation, please brake quickly to avoid accidents.

## 2. Spare Parts description

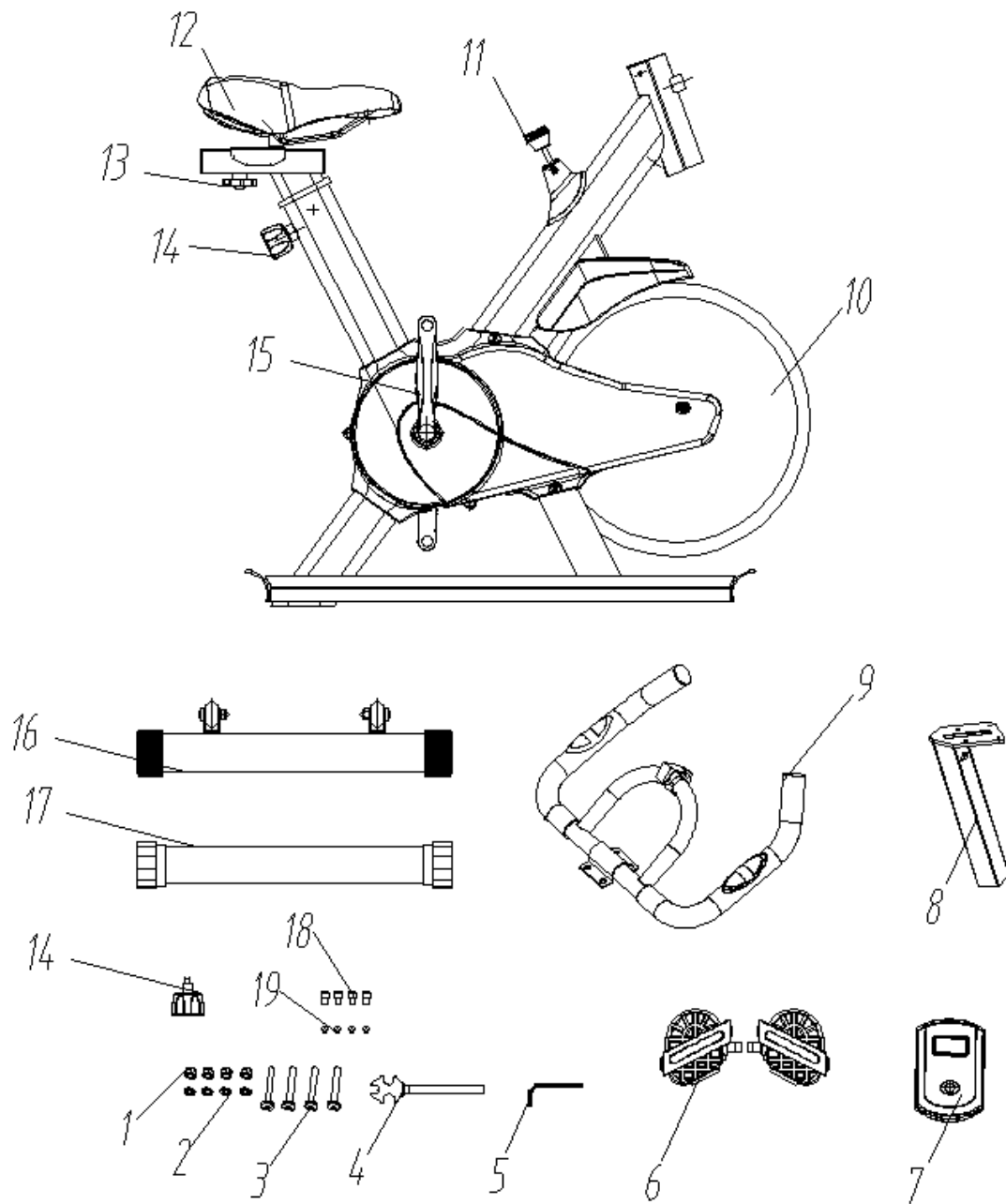

1. cover screw M8	5. monitor	9. brake	13. crank	17. handle support
2. wrench	6. handle	10. saddle	14. plastic cover chain	18. Cylinder head screw M6
3. wrench	7. plastic cover	11. plum-head bolts	15. front feet tube	19. corrugated pipe
4. pedal	8. flywheel	12. broaching	16. back feet tube	

### 3. Installation Instruction



1) Connect the front tube with the frame, and install the plain washer 8, washer 8 to the bolts and put on the cover-shaped screws. And use open spanner to fasten them. Installation of back tube is the same.

Note: Please adjust the black feet strap to make it balance if it is not stable.



2).The feet straps are marked with L and R. Please drop 2 red screw locking liquid in R

strap and fasten it with right threaded hole by using our spanner. And drop 2 red screw locking liquid in L strap and fasten it with left threaded hole.

(Note: L and R are marked in crank as well. Please install them accordingly otherwise it will damage the products. And please fasten the feet strap, or it will fall down after long usage.)



3、 To adjust the height of seat, please rotate knob to the left then loose the knob as B and adjust the cushion by up and down to appropriate height. Loose the knob to make it through the hole of saddle support then just lock it please (same as adjust the height of handle)





4、 Take out the handle and then put four holes of handle into screwed hole, next put washer and through Cylinder head screw, then support by screws one by one.



5、 1)Fasten the electronic watch by fastening the slots  
2). Connect the cables as A.(suitable for model without pulse function)  
3). Double wire with right Pulse and single wire with left sensor. Please keep the messy cables inside the tube for beauty



6、 take out the plastic cover, put it on the handle like the picture.



7、 Rotate the break knob clockwise to increase the resistance and rotate the break knob anticlockwise to decrease the resistance. Press down the break knob for emergency stop.

## 4. LCD Monitor

### SPECIFICATION:



<b>TIME</b> -----	0:00-99:59 MIN:SEC
<b>SPEED</b> -----	0:00-999.9 ML/H
<b>DISTANCE</b> -----	0.0-999.9 ML
<b>CALORIE</b> -----	0.0-999.9 KCAL
<b>ODOMETER</b> -----	0.0-999.9 ML
<b>PULSE</b> -----	40-240 BEATS/MIN

### LCD MONIOTR FUNCTIONS:

**AUTO ON/OFF:** If you leave the computer idle for 4 minutes, the power will shut off automatically.

**SCAN:** Press the button until the screen displays SCAN; the computer will automatically scan the function of TIME, ODOMETER, CALORIE, PULSE,SPEED, and DISTANCE, every 6 seconds.

**TIME:** displays your elapsed workout time in the minutes and seconds. The computer will automatically count up from 0:00 to 99:59 in one second intervals.

**SPEED:** Displays your workout speed in miles per hour.

**DISTANCE:** Displays the accumulative distance traveled during each workout up to a maximum of 999.8 miles.

**CALORIE:** The computer will estimate the cumulative calories burned at any given time during your workout. The computer will count up from 0.0 to 999.9

calories.

**ODOMETER:** Displays the total accumulative distance traveled during each workout up to a maximum of 999.9 miles. The data values of ODOMETER can not be reset to zero by pressing and holding the button more than 2 seconds. If user takes out the batteries from the computer, the ODOMETER data values will reset to zero.

**PULSE:** The computer will display your pulse rate in beats per minute after holding both hands on handlebar grip sensors during exercise. To ensure grip sensors with two hands instead of one.

**RESET:** Pressing and holding the button more than 2 seconds will reset all functional values to zero except the odometer data values.

**HOW TO INSTALL THE BATTERIES:**

1. Remove the battery cover at the rear of computer.
2. Place two "SIZE-AAA" batteries into the battery housing.
3. Insure batteries are correctly positioned and battery springs are in proper contact with batteries.
4. Re-install the battery cover.
5. If the displays are illegible or only partial legible, remove batteries and wait 15 seconds before reinstalling.

## 5. Adjustment



### **Adjusting the Tension Control Knob**

To increase the tension, turn the tension control knob in a clockwise direction.

To decrease the tension, turn the tension control knob in a counterclockwise direction

### **Adjusting the Seat Height**



Turn the seat height adjustment knob in a counterclockwise direction until the seat post can be slid up or down and then slide the seat post up or down direction to the suitable position. Lock the seat post in place by tightening the seat height adjustment knob in a clockwise direction.

**NOTE: When adjusting the height of seat post, make sure the seat post plastic bushing does not exceed the mark line on the seat post.**

## **6. Maintenance & Troubleshooting**

### **6.1). Maintenance**

#### 6.1.1). Cleaning

Use soft cloth to wipe the dust on the bike. Don't use abrader or scrubbing to clean plastic parts. Wipe the sweat after use.

#### 6.1.2). Maintenance

Please avoid direct sunlight, especially the electronic watch which is very vulnerable.

Every week, please check all the bolts and screws to see if they are loose and keep them fastened. Please keep the bike in clean and dry environment and be away from children.

## **6.2).Troubleshooting**

6.2.1). To solve the wagging problem of bike, please move and rotate the pedals until it is stable.

6.2.2). If screen of the electronic watch does not display anything, please check whether cables in armrest and digital are connected correctly; whether the battery is installed correctly. If it is out of battery, please replace the battery.

6.2.3). If it does not replay the heartbeat rate or replay it abnormally, please check whether the cable in armrest is connected correctly. Please make sure you hold the armrest sensors; please do not grasp the sensors too tight. (suitable for model with pulse function)

6.2.4). If there is abnormal sound during usage, Please check if the bolts are loose and ensure the bolts are tightened.

## **7. Warm Up**

### **7.1.) Quadriceps Stretch**



With one hand against a wall for balance, reach behind you and pull your right foot

up. Bring your heel as close to your buttocks as possible. Hold for 15 counts and repeat with left foot up.

### **7.2.) Inner Thigh Stretch**



.Sit with the soles of your feet together with your knees pointing outward. Pull your feet as close into your groin as possible.

.Gently pushes your knees towards the floor. Hold for 10 Counts.

### **7.3.)Toe Touches**



Slowly bend forward from your waist, letting your back and shoulders relax as

You back and shoulders relax as you stretch toward your toes. Reach down as far as you can and hold for 15 counts.

### **7.4.) Hamstring Stretches**





Sit with your right leg extended. Rest the sole of your left foot against your right inner thigh. Stretch toward your toe as far as possible. Hold for 15 counts Relax and then repeat with left leg extended

### **7.5.) Hamstring Stretches**



Sit with your right leg extended. Rest the sole of your left foot against your right inner thigh. Stretch toward your toe as far as possible. Hold for 15 counts Relax and then repeat with left leg extended.

## **8. Package Contents**

1× Exercise Bike

1× Toolkit

1× Monitor

1× Plastic Foot Set

1× User Manual

## **9. Warranty**

**COMPONENT LENGTH OF WARRANTY: 1 year**

Inland Products, Inc., Warrants this product to be free of defects in materials or workmanship for one year. This warranty does not include damage resulting from accident to misuse. If this product should become defective, we will replace it free of charge provided it is prepaid freight to: inland Products, Inc. This warranty is in lieu of all other warranties expressed or implied including the implied warranties on merchantability of fitness for any other rights or remedies. In no event shall inland Products Inc., be liable for consequential damages. Register your warranty online at [www.inlandus.com](http://www.inlandus.com).

**Mandatory California Proposition 65 Warning:** This product may contain chemicals know to state of California to cause cancer, birth defects, and/or other reproductive harm.