

# MANOR 6' x 4'

Manor Shed | Abri de rangement Manor | Cobertizo Manor | Manor Schuppen | Manor-schuurtje | Deposito Manor | Abrigo Manor

130W x 193D x 197.5H cm | 51"L x 76"W x 78"H

ASSEMBLY INSTRUCTIONS | CONSIGNES DE MONTAGE | INSTRUCCIONES DE MONTAJE | MONTAGE-ANLEITUNG | SAMLEVEJLEDNING | MONTAGE-VOORSCHRIFTEN | ISTRUZIONI D'ASSEMBLAGGIO | INSTRUÇÕES DE MONTAGEM



WWW.KETER.COM



## CUSTOMER SERVICE

**IMPORTANT:** For assistance with assembly, or to request missing parts, please log on to our website at [www.keter.com](http://www.keter.com), or contact Customer Service.

**IMPORTANT :** Pour bénéficier d'une assistance lors du montage ou pour réclamer des pièces manquantes, veuillez vous connecter sur notre site web [www.keter.com](http://www.keter.com) ou contacter le Service clients.

**IMPORTANTE:** Para recibir asistencia sobre el montaje o para solicitar partes faltantes, ingrese a nuestra página de Internet [www.keter.com](http://www.keter.com) o contáctese con Atención al Cliente.

**WICHTIG:** Für Hilfe bei der Montage oder um fehlende Teile anzufordern, loggen Sie bitten in unsere Internet Seite [www.keter.com](http://www.keter.com) ein oder kontaktieren Sie den Kundendienst.

**BELANGRIJK:** Ga voor hulp bij het monteren of voor het aanvragen van onderbrekende onderdelen naar onze website op [www.keter.com](http://www.keter.com) of neem contact op met de Klantenservice.

**IMPORTANTE:** Per assistenza sull'assemblaggio o per richiedere parti mancanti, collegarsi al nostro sito web [www.keter.com](http://www.keter.com), oppure contattare il Servizio Clienti.

**IMPORTANTE:** Para obter assistência sobre a montagem ou para solicitar peças registre-se no nosso site de Internet [www.keter.com](http://www.keter.com) ou contacte o serviço de assistência ao cliente.

### U.S.

Call Toll Free: 1-(888)-374-4262

Fax: 317-575-4502 11495 North Pennsylvania St., Suite 110, Carmel, Indiana, 46032, U.S.A.

### Canada

Appel gratuit: 1-(800)-661-6721

Call Toll Free: 1-(800)-661-6721

### United Kingdom:

Keter (UK) Ltd.

Unit 4, Woodgate Business Park, Clapgate Lane, Birmingham, B32 3DB, United Kingdom.

Tel: 0121-5060008, Fax: 0121-4220808

### Spain

Eduardo Cobo

SPV KETER

TLF:0034 949 27 74 21

FAX:0034 949 34 89 76

### Scandinavia

Kim M. Nielsen [[kim@deos.dk](mailto:kim@deos.dk)]

+45 - 70 70 21 99

### Germany

Phone: +49(0)6074-8931-0

Telefax: +49(0)6074-8931-11

Email: [info@tepro-gmbh.de](mailto:info@tepro-gmbh.de)

### France

00 33 1 34 07 99 00

[courriel@comintes.com](mailto:courriel@comintes.com)

### Other European Countries:

Keter Benelux

Ericssonstraat 17, Postbus 224, 5120 AE Rijen, the Netherlands. Tel: 31-1612-28301,

Fax: 31-1612-28322

## REQUIRED TOOLS

The following tools are required for shed assembly:



EN

## LEVEL THE GROUND

PLEASE SELECT YOUR CONSTRUCTION SITE CAREFULLY. THE GROUND SURFACE MUST BE LEVEL. IT IS HIGHLY RECOMMENDED THAT YOU CONSTRUCT A WOODEN OR CONCRETE BASE TO USE AS A FOUNDATION.



Assembly requires two people

- Clear area of stones
- Remove all plants, roots and other debris
- Rake the ground
- Make the ground level using a long, flat object (e.g., wood beam)
- In order to properly assemble some parts of the shed, it should be kept 27 inches / 70 cm from any fence or wall until fully assembled
- External base measurements are:  
73"W x 50"D / 185W x 125D cm

## CAUTION

Some parts have steel edges. Please be careful when handling components. Always wear work gloves, eye protection and long sleeves when assembling or performing any maintenance on your shed. Do not attempt assembly on days with strong winds or low temperatures.

## BEFORE STARTING ASSEMBLY

- Remove all of the pieces from the package and spread them out on the ground.
- It is recommended to use a clean work surface to spread the parts out and for pre-assembly.
- Review all instructions before you begin, continue to refer to instructions during assembly.
- Be sure to follow all steps thoroughly.

FR

## NIVELLEMENT DU SOL

VEUILLEZ SÉLECTIONNER LE SITE DE VOTRE CONSTRUCTION AVEC PRÉCAUTION. LA SURFACE DU SOL DOIT ÊTRE PLANE. IL EST FORTEMENT RECOMMANDÉ DE CONSTRUIRE UNE BASE EN BOIS OU SOLIDE AFIN DE L'UTILISER COMME FONDATION.



Le montage doit être effectué par deux personnes.

- Retirez toutes les pierres.
- Arrachez toutes les plantes, racines et autres obstacles.
- Ratissez le sol.
- Aplanissez le sol à l'aide d'un objet long et plat (une planche en bois par exemple).
- Pour monter correctement les parties de l'abri, vous devez garder 27 pouces / 70 cm de distance d'un obstacle ou d'un mur jusqu'à son assemblage complet.
- Les mesures externes de la base sont:  
73" x 50" / 185 cm x 125 cm (l x L)

## AVERTISSEMENT

Certaines pièces ont des bords en acier. Soyez prudent en les manipulant. Portez toujours des gants de travail, des lunettes de protection et des vêtements à manches longues lors de l'assemblage ou de l'accomplissement d'activités d'entretien sur votre abri. N'essayez pas de réaliser le montage les jours de grand vent ou de grand froid. Veuillez vérifier régulièrement que les vis sont bien serrées.

## AVANT DE COMMENCER LE MONTAGE

- Retirez les pièces du paquet et les répartir sur le sol.
- Il est recommandé d'utiliser une surface de travail propre pour répartir les pièces à l'extérieur et pour les étapes de pré-montage.
- Lisez bien toutes les instructions avant de commencer et continuez à vous y référer pendant le montage.
- Assurez-vous de suivre scrupuleusement toutes les étapes.

**ES**

## NIVELE EL SUELO

SELECCIONE CON CUIDADO EL LUGAR DONDE COLOCARÁ SU COBERTIZO. LA SUPERFICIE DEL SUELO DEBE SER PAREJA. LE RECOMENDAMOS ESPECIALMENTE QUE CONSTRUYA UNA BASE DE MADERA O CEMENTO PARA USAR COMO CIMIENTO.



Se necesitan dos personas para armarlo.

- Saque las piedras del área.
- Retire todas las plantas, raíces y otros obstáculos.
- Rastrille la tierra.
- Nivela el suelo usando un objeto largo y plano (por ejemplo, una viga de madera).
- Para armar correctamente algunas de las partes del cobertizo, debe mantenerse a 27 pulgadas / 70 cm de distancia de cualquier cerca o pared, hasta que esté completamente armado.
- Las medidas externas de la base son: 185 cm An. x 125 cm Pr.

## ADVERTENCIA

Algunas partes tienen bordes de acero. Tenga cuidado al manejar estos componentes. Use siempre guantes de trabajo, anteojos protectores y mangas largas para armar el cobertizo o realizar cualquier tarea de mantenimiento en el mismo. No intente armar el cobertizo en días de viento fuerte o de baja temperatura.

## ANTES DE EMPEZAR EL ARMADO

- Retire todas las partes del paquete y distribúyalas sobre el suelo.
- Se recomienda usar una superficie de trabajo limpia para diseminar las partes y para realizar los pasos de prearmado.
- Lea todas las instrucciones antes de empezar, y siga remitiéndose a ellas durante el armado.
- Asegúrese de seguir todos los pasos con atención.

**DE**

## SORGEN SIE FÜR EINE EBENE GRUNDFLÄCHE

BITTE WÄHLEN SIE IHREN MONTAGESTANDORT SORGFÄLTIG AUS. DIE BODENFLÄCHE MUSS EBEN SEIN. ES WIRD EMPFOHLEN, DASS SIE EINE HOLZ- ODER BETONUNTERLAGE ALS FUNDAMENT ANLEGEN.



Zwei Personen zur Montage notwendig.

- Beseitigen Sie Steine.
- Entfernen Sie alle Pflanzen, Wurzeln und andere Hindernisse.
- Pflügen Sie den Boden durch.
- Ebenen Sie den Boden mit Hilfe eines langen, flachen Objektes (wie z.B. eines Holzbalken) aus.
- Um verschiedene Montageteile des Schuppens richtig zu montieren, sollte während der Montage ein Mindestabstand von 27" / 70 cm von jeglichem Zaun oder Wand eingehalten werden.
- Äußere Abmessungen der Grundfläche betragen: 185cm L x 125cm B

## WICHTIG

Manche Teile haben Stahlkanten, bitte seien Sie vorsichtig beim Umgang dall'imballaggio. Tragen Sie bei der Montage des Gartenschuppens oder Wartungsarbeiten stets Arbeitshandschuhe, eine Schutzbrille und Kleidungsstücke mit langen Ärmeln. Versuchen Sie nicht, den Gartenschuppen bei starkem Wind oder niedrigen Temperaturen zu montieren.

## VOR MONTAGEBGINN

- Entnehmen Sie alle Teile aus der Verpackung und legen Sie diese auf dem Boden aus.
- Es wird empfohlen, die Einzelteile auf einer sauberen, glatten Unterfläche auszubreiten und Vorbereitungen für den Zusammenbau zu treffen.
- Lesen Sie die Anleitung vor Beginn der Montage gründlich durch und richten Sie sich dann nach dieser.
- Vergewissern Sie sich, dass Sie allen Montageschritten genau folgen.

NL

## MAAK DE GROND EGAAL

SELECTEER MET ZORG UW BOUWPLAATS. HET OPPERVLAKE VAN DE GROND MOET EGAAL ZIJN. HET WORDT TEN ZEERSTE AANGERADEN DAT U EEN HOUTEN OF BETONNEN BASIS MAAKT OM ALS FUNDAMENT TE GEBRUIKEN.



Montage vereist twee personen

- Verwijder stenen.
- Verwijder alle planten, wortels en andere obstakels.
- Hark de grond.
- Maak de grond met een lang, vlak onderwerp (bijv. een houten balk) egaal.
- Om de onderdelen van het schuurtje juiste te monteren, moeten zij ongeveer 70 cm/27 inch van een heg of muur worden geplaatst totdat het volledig is gemonteerd.
- Buitenste afmetingen van de basis zijn: 185B x 125D cm

## WAARSCHUWING

Sommige onderdelen hebben stalen randen. Wees voorzichtig met het omgaan met deze onderdelen. Draag altijd werkhandschoenen, oogbescherming en lange mouwen als u uw schuurtje monteert of onderhoud. Probeer niet te monteren op dagen met sterke wind of lage temperaturen.

## VOORDAT U BEGINT TE MONTEREN

- Verwijder alle onderdelen uit de verpakking en spreidt ze uit over de grond.
- U wordt aanbevolen een schoon werkoppervlak te gebruiken om de onderdelen op uit te spreiden en voor de voorbereiding op de montage
- Bekijk alle instructies voordat u begint en raadpleeg tijdens de montage de instructies.
- Zorg dat u alle stappen uitvoerig opvolgt.

IT

## LIVELLAMENTO DEL TERRENO

SCEGLIERE CON CURA LA POSIZIONE OVE MONTARE LA CASETTA. LA SUPERFICIE DEL TERRENO DEVE ESSERE BEN LIVELLATA. SI RACCOMANDA VIVAMENTE DI COSTRUIRE UN BASAMENTO IN LEGNO O IN CALCESTRUZZO, DA UTILIZZARE COME FONDAMENTA.



Il montaggio richiede due persone

- Eliminare le pietre
- Rimuovere piante, radici e altri ostacoli
- Livellare il terreno
- Mettere a livello il terreno utilizzando un oggetto lungo e piatto (ad es. un asse di legno)
- Per garantire il corretto assemblaggio di alcune parti, il capanno andrebbe tenuto a una distanza di circa 27" / 70 cm da eventuali recinzioni o muri fino al termine dell'assemblaggio.
- Dimensioni esterne della base: 185 L x 125 P.

## ATTENZIONE

Alcune parti presentano bordi in acciaio. Fare attenzione nel maneggiare i componenti. Indossare sempre guanti da lavoro, protezioni per gli occhi e maniche lunghe durante il montaggio o durante la manutenzione. Evitare di effettuare il montaggio in presenza di forte vento o basse temperature.

## PRIMA DI INIZIARE MONTAGGIO

- Rimuovere tutti i pezzi mit allen Teilen e metterli da una parte.
- Si raccomanda l'uso di un piano da lavoro sgombro per la sistemazione dei componenti e lo svolgimento delle fasi di preassemblaggio
- Rileggere tutte le istruzioni prima di iniziare e continuare a fare riferimento alle istruzioni anche durante il montaggio.
- Accertarsi di seguire attentamente tutte le fasi.

PT

## NIVELAR O SOLO

POR FAVOR, ESCOLHA O LOCAL DE CONSTRUÇÃO CUIDADOSAMENTE. A SUPERFÍCIE DO SOLO DEVE SER NIVELADA. RECOMENDA-SE VIVAMENTE QUE CONSTRUA UMA BASE DE MADEIRA OU DE CIMENTO PARA USAR COMO FUNDAÇÕES.



A montagem exige duas pessoas

- Retire as pedras do local
- Retire todas as plantas, raízes e outros obstáculos
- Alise o local
- Nivele o solo utilizando um objecto comprido e plano (por exemplo, uma trave de madeira)
- De modo a montar correctamente algumas partes do abrigo, deve permanecer a 27 polegadas / 70 cm de qualquer vedação ou parede até que esteja totalmente montada.
- As medidas base externas são:  
73"L x 50"P / 185L x 125P cm

## ATENÇÃO

Algumas peças têm extremidades de aço. Tenha cuidado ao manusear estes componentes. Utilize sempre luvas e óculos de protecção, assim como vestuário comprido ao montar ou efectuar qualquer procedimento de manutenção no seu abrigo de jardim. Não monte o abrigo de jardim em dias de vento forte ou de baixas temperaturas.

## ANTES DE INICIAR A MONTAGEM

- Retire todas as peças das embalagens e coloque-as no chão.
- Recomenda-se o uso de uma superfície de trabalho limpa para distribuir as peças e para os passos de pré-montagem
- Leia todas as instruções antes de iniciar e consulte-as durante a montagem.
- Siga atentamente os seguintes passos.

# PARTS

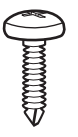
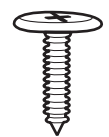
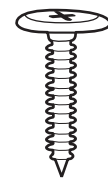
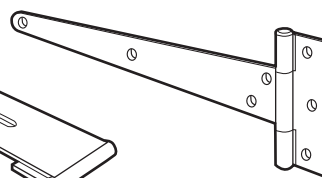
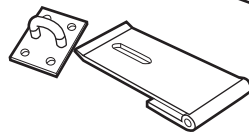
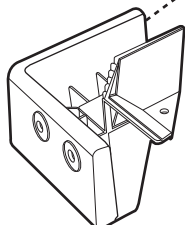
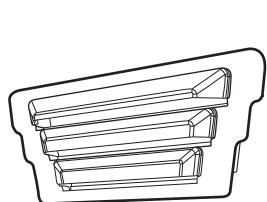
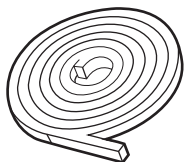
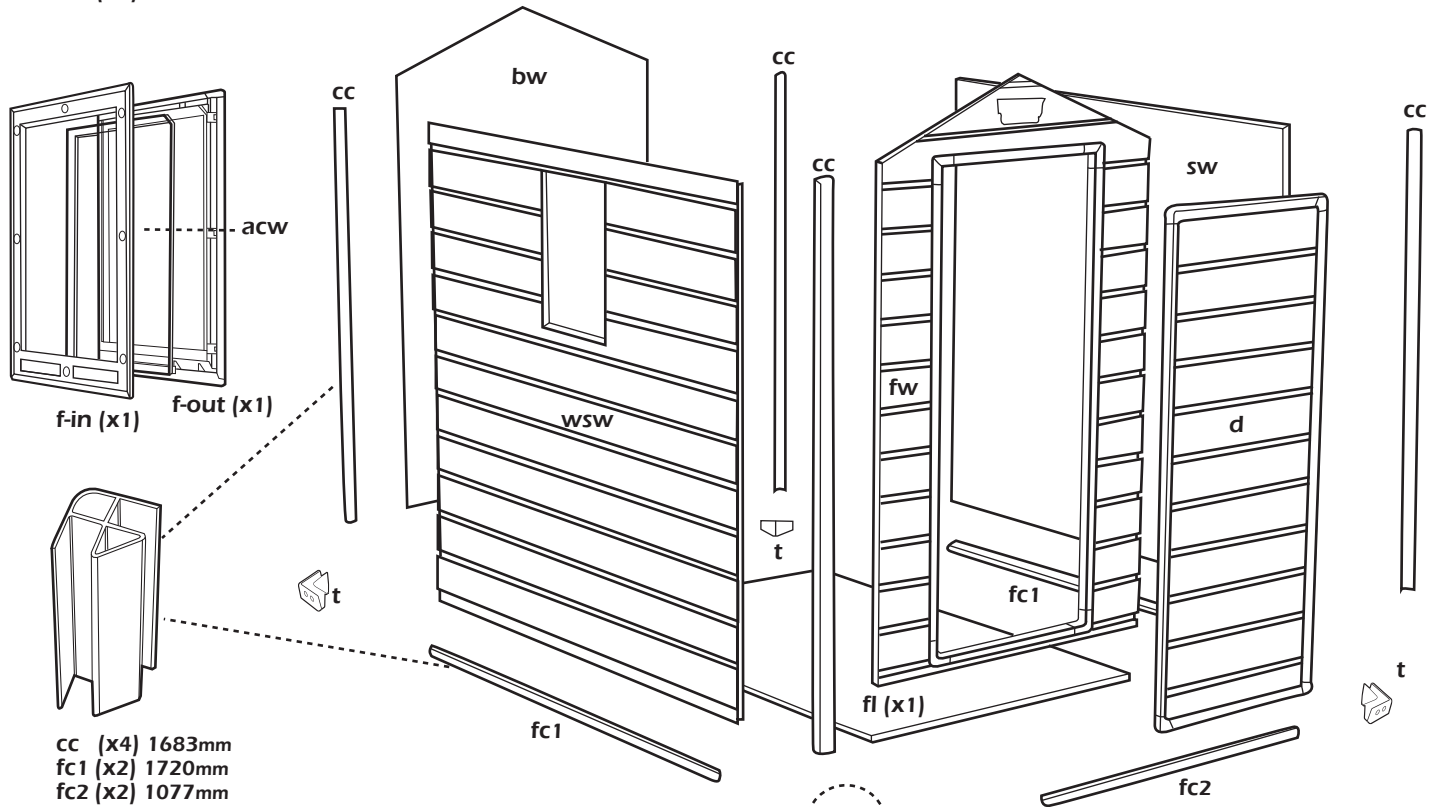
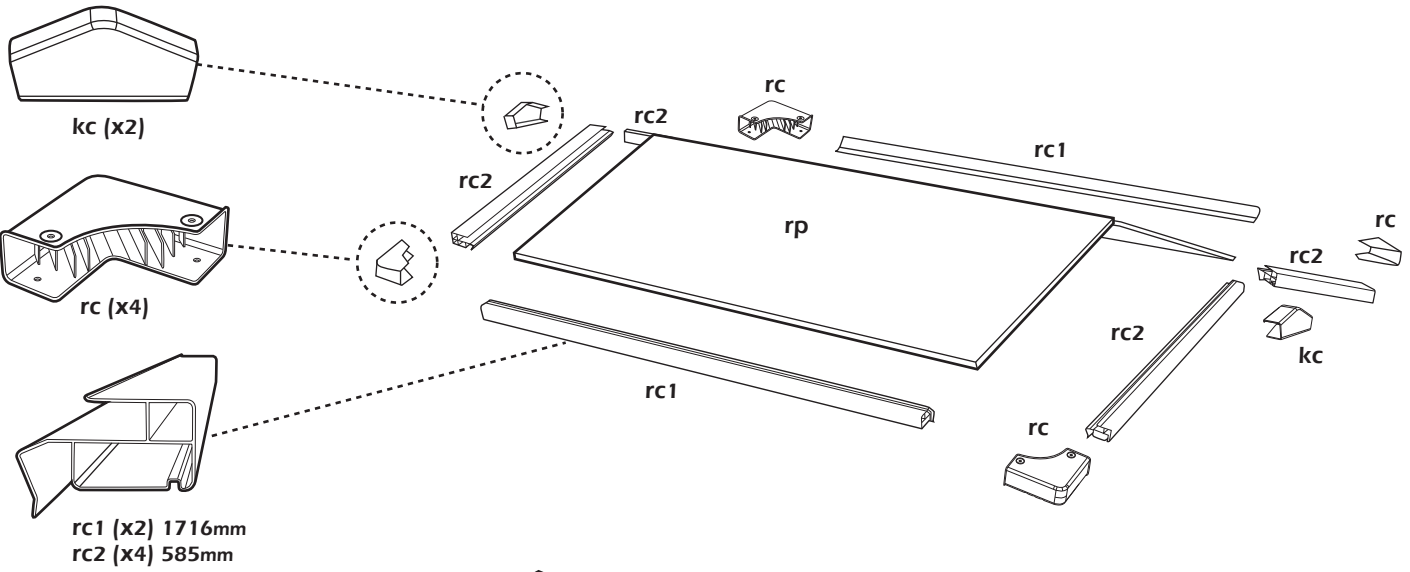

s12b (x21)  
12mm

# FLOOR ASSEMBLY

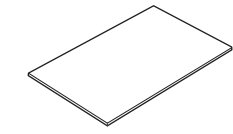

fl (x1)  
1130x1770mm



fc1 (x1)  
1720mm



fc2 (x1)  
1075mm

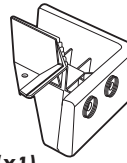

t (x1)

**1**

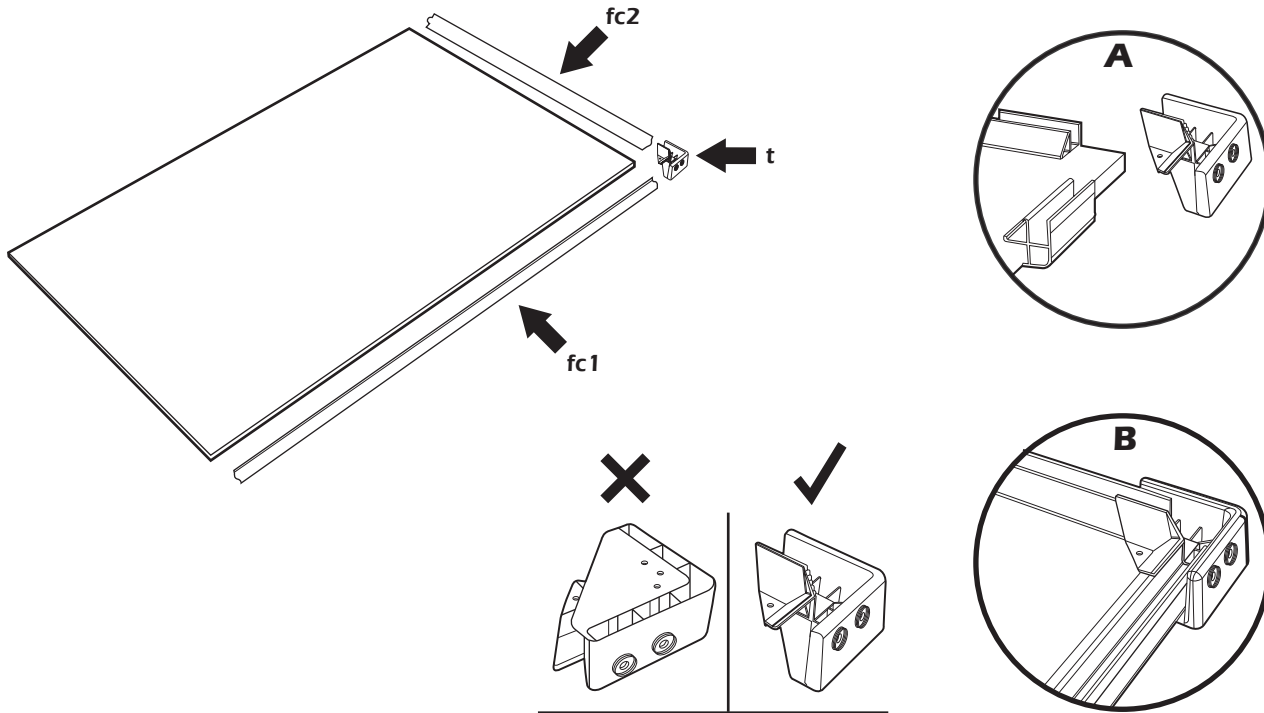

fc1 (x1)  
1720mm



fc2 (x1)  
1075mm

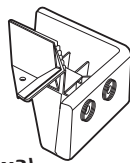

t (x3)

**2**

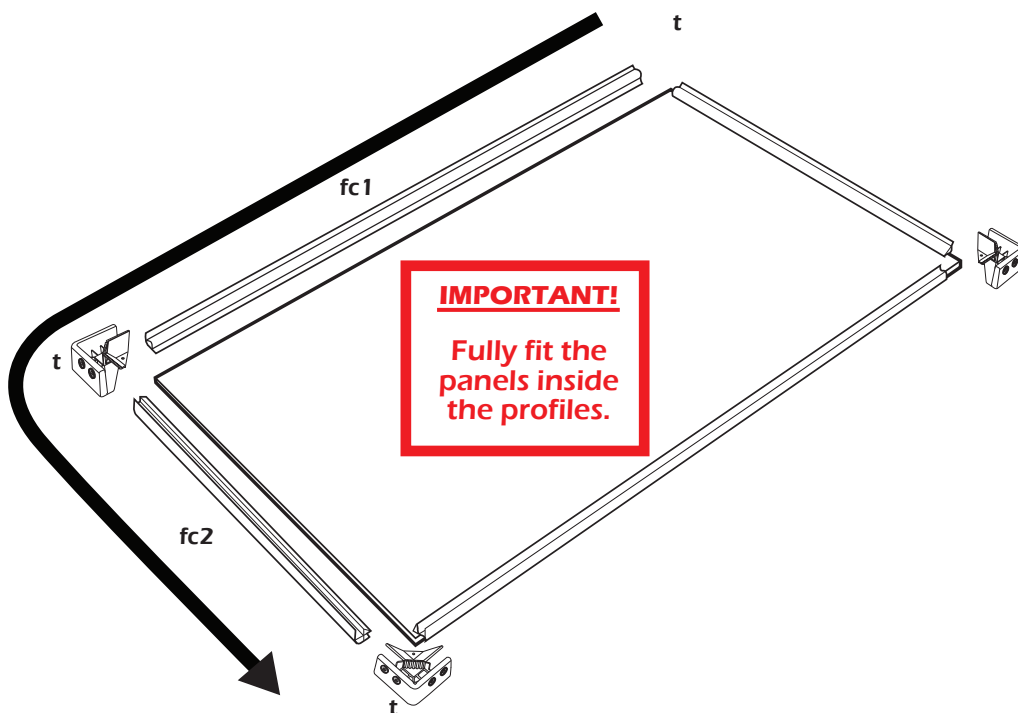

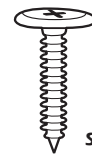

s26b (x10)  
26mm

**3**

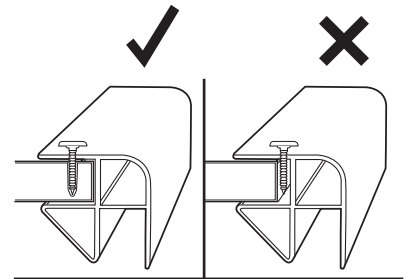
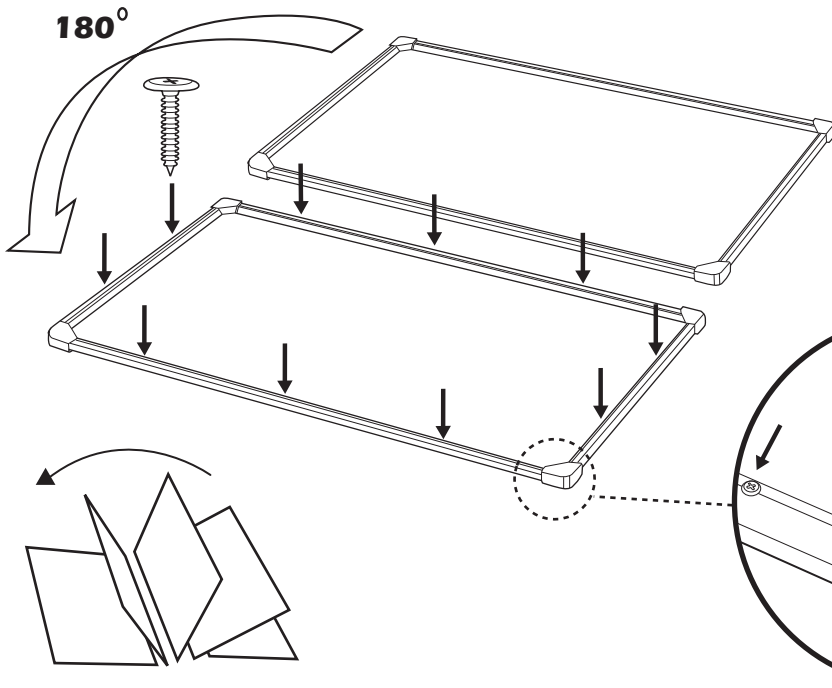

**IMPORTANT!**

Fully fit the  
panels inside  
the profiles.

**4**

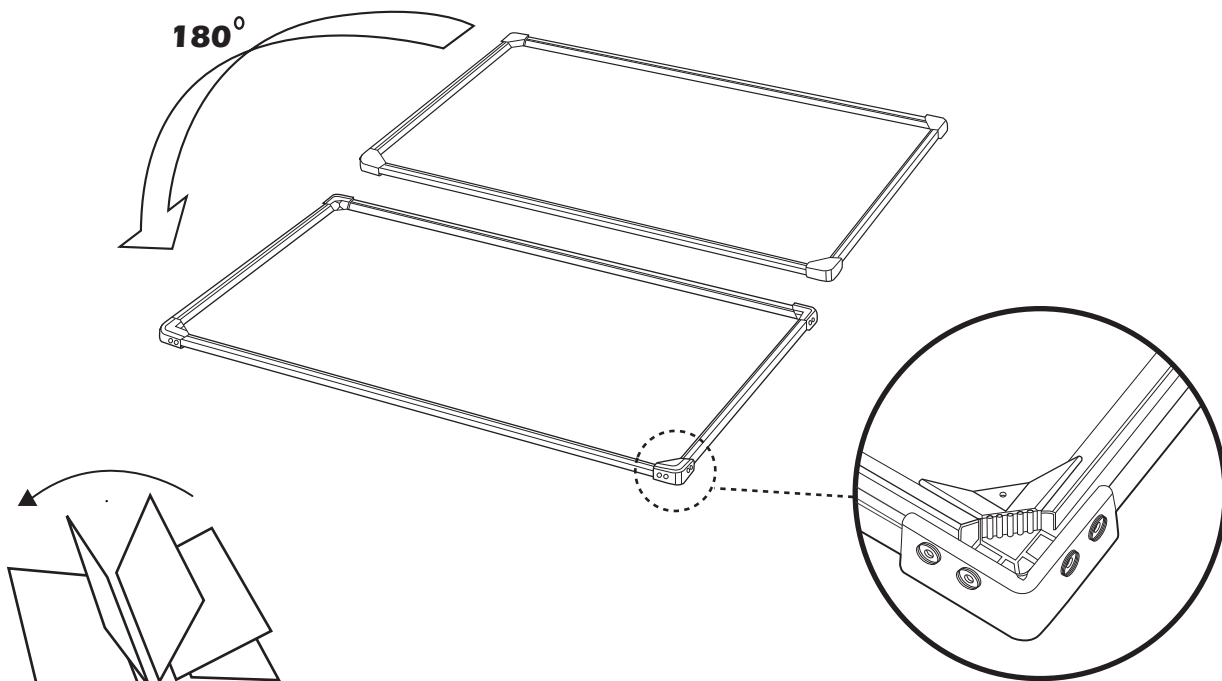



# DOOR ASSEMBLY



fw (x1)



d (x1)

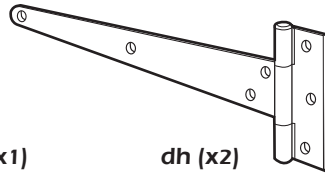

dh (x2)

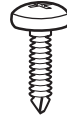

s12b (x21)  
12mm

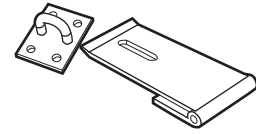

dl (x1)

# 5

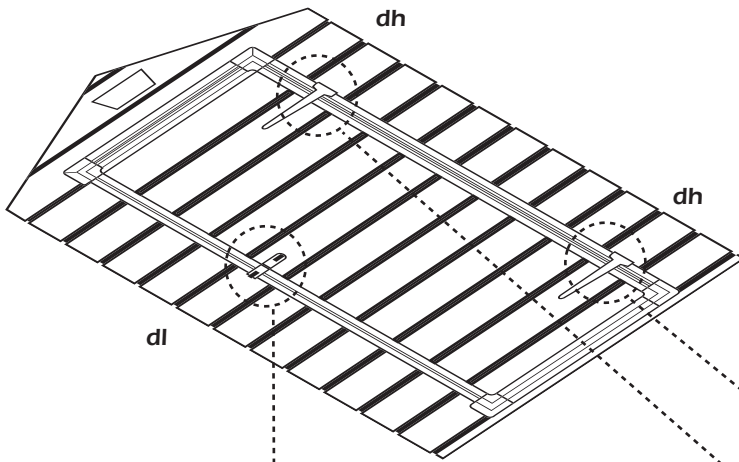
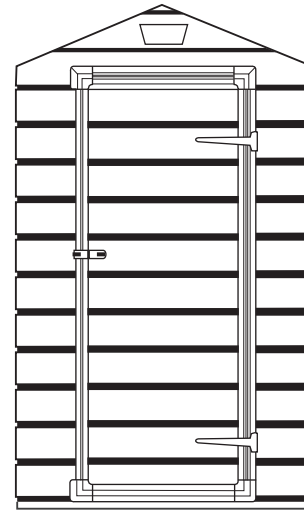

dl

dh

dh

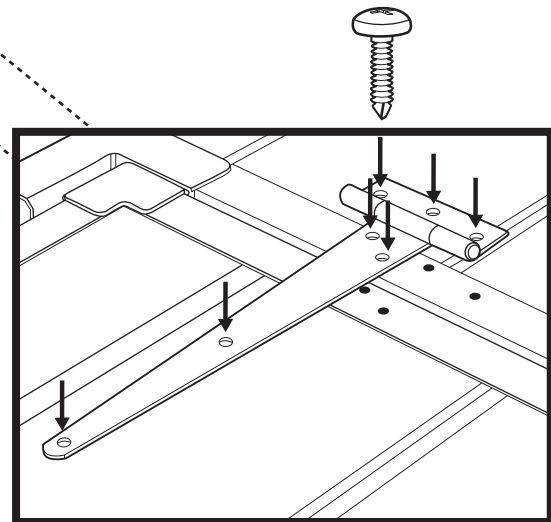
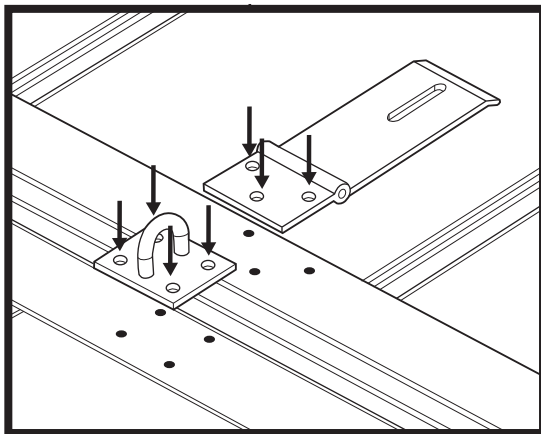
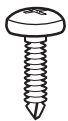

# WALL ASSEMBLY

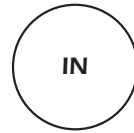
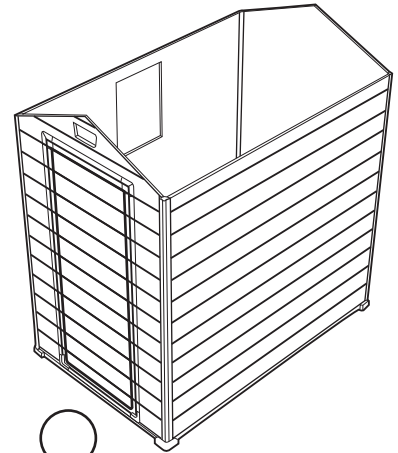
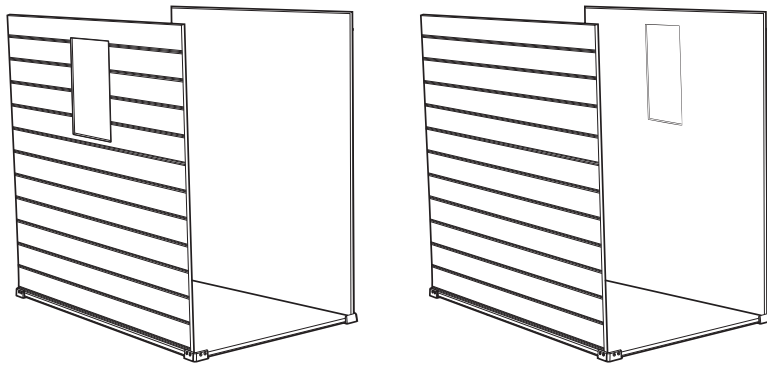

On which side of the shed do you want your **window** ?  
Assemble the panel with the window opening on the direction you want it to be

cc (x1)  
1680mm



# 6

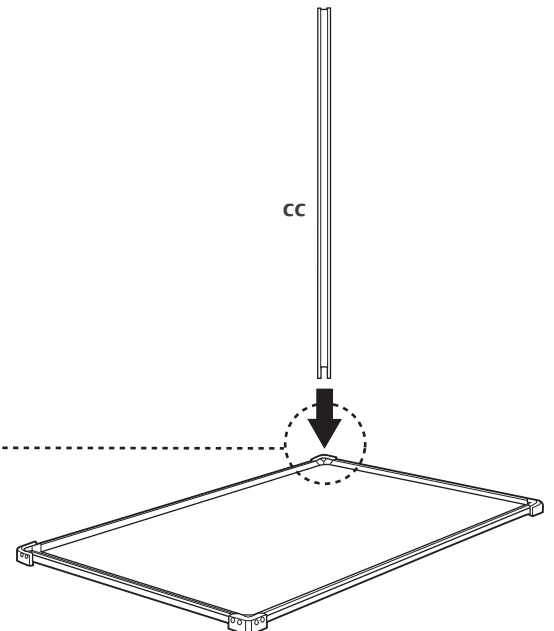
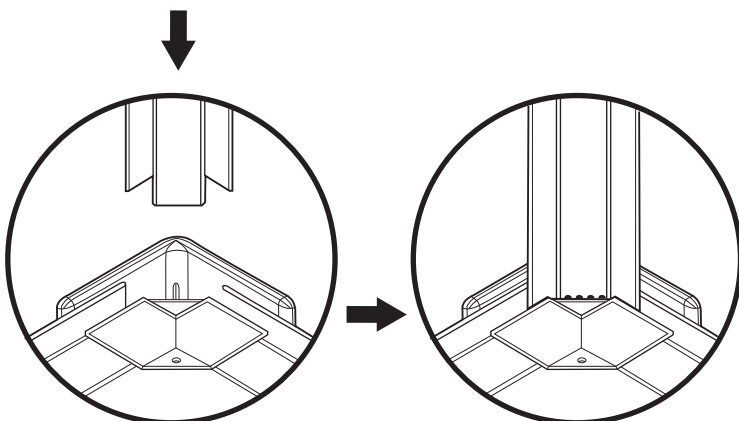

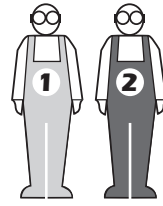
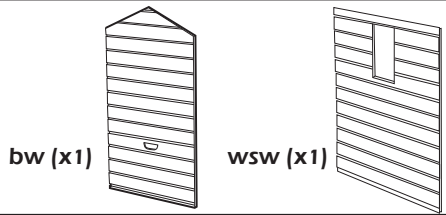

**7**

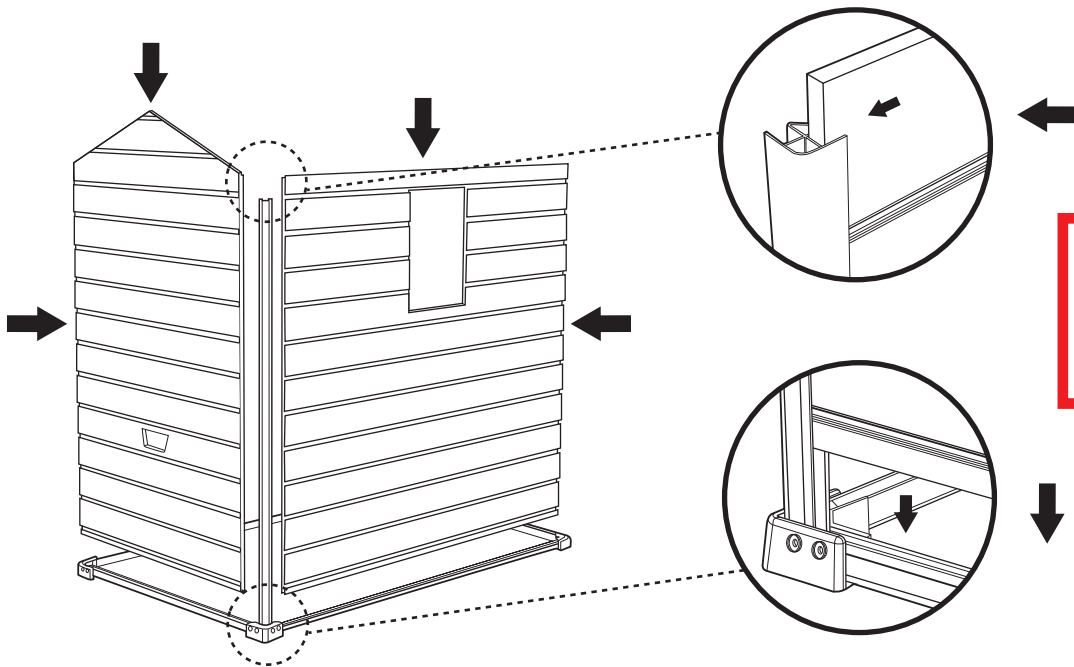

**IMPORTANT!**  
Fully fit the panels inside the profiles.

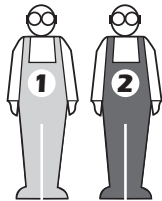
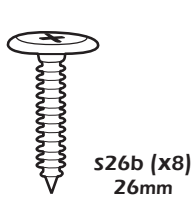

**8**

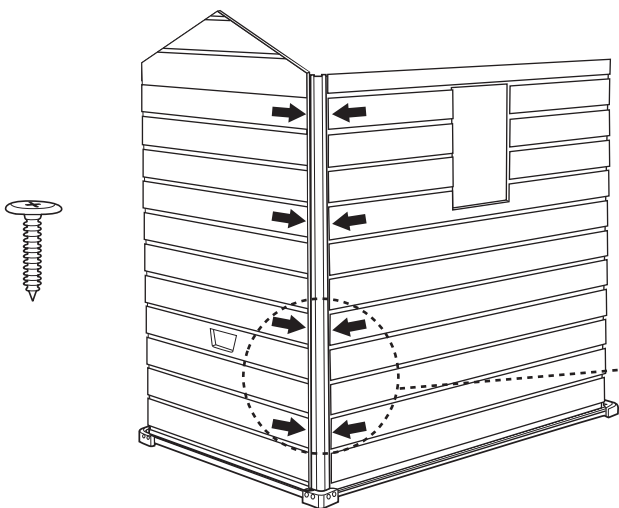

**IMPORTANT!**  
Fully fit the panels inside the profiles.

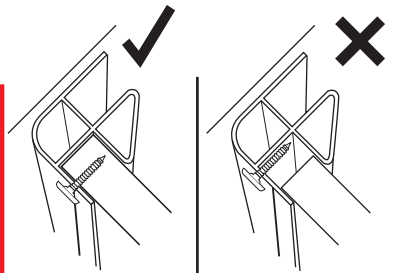

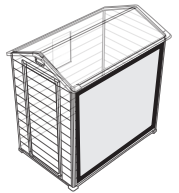

sw (x1)

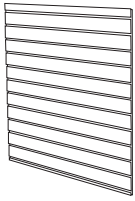

cc (x1)  
1680mm

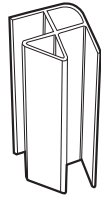

s26b (x8)  
26mm

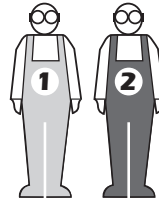
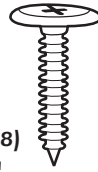

9

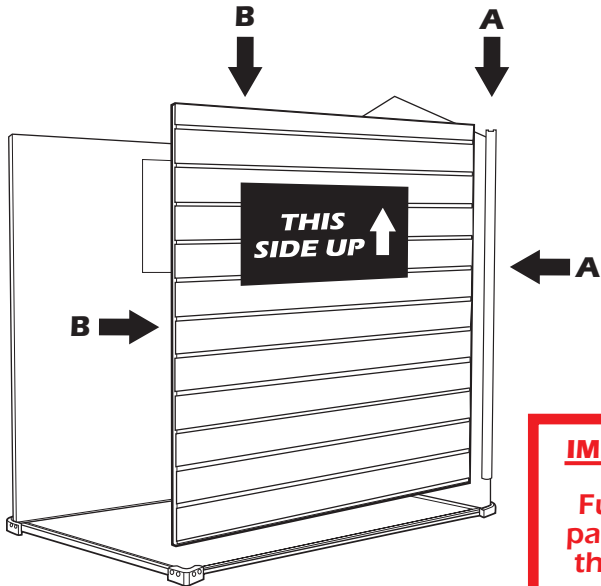

**IMPORTANT!**  
Fully fit the panels inside the profiles.

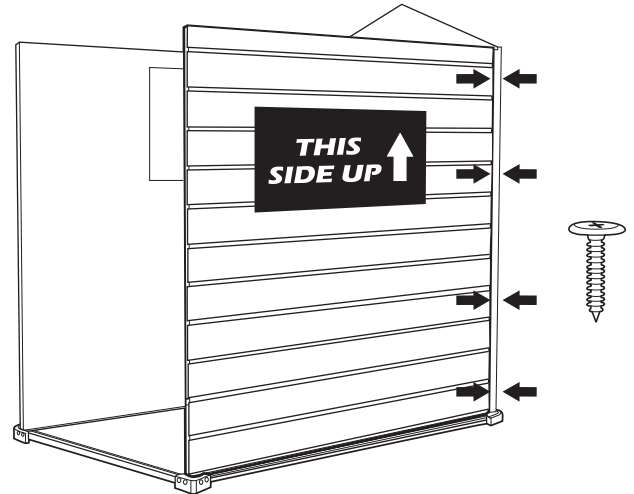

fw+d (x1)



cc (x1)  
1680mm

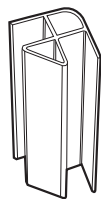

s26b (x8)  
26mm

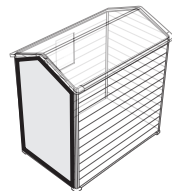
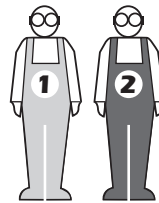
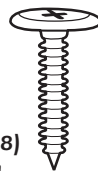

10

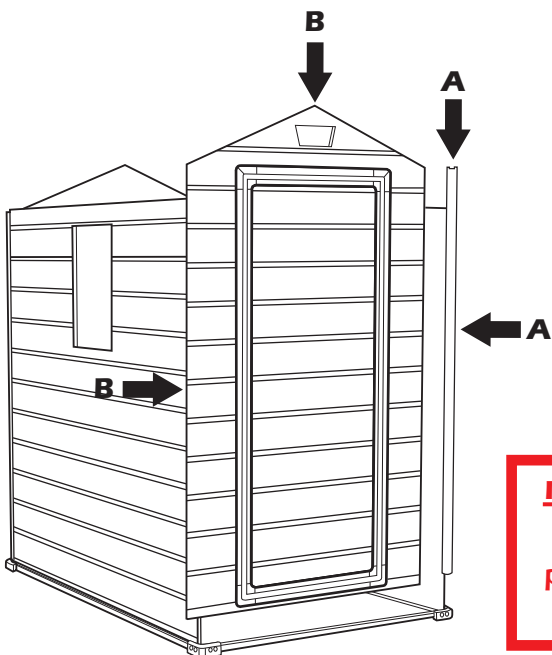

**IMPORTANT!**  
Fully fit the panels inside the profiles.

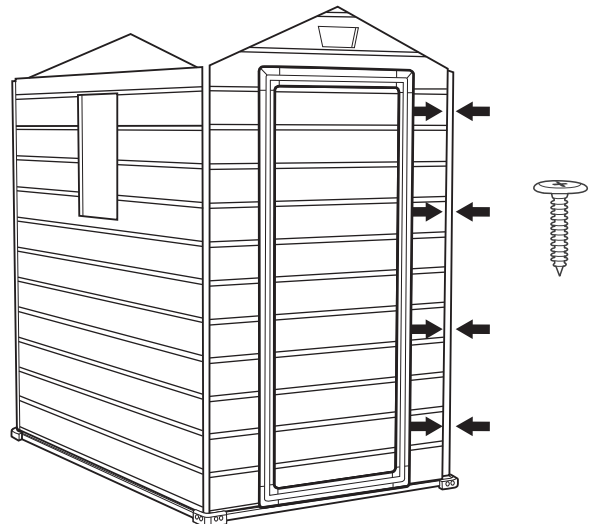



cc (x1)  
1680mm



s26b (x8)  
26mm

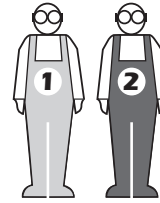
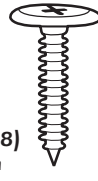

11

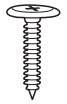
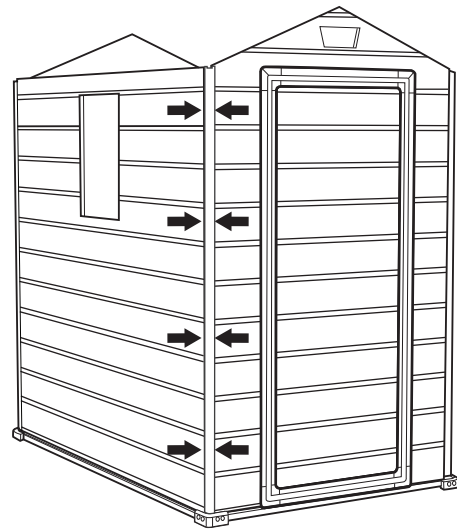
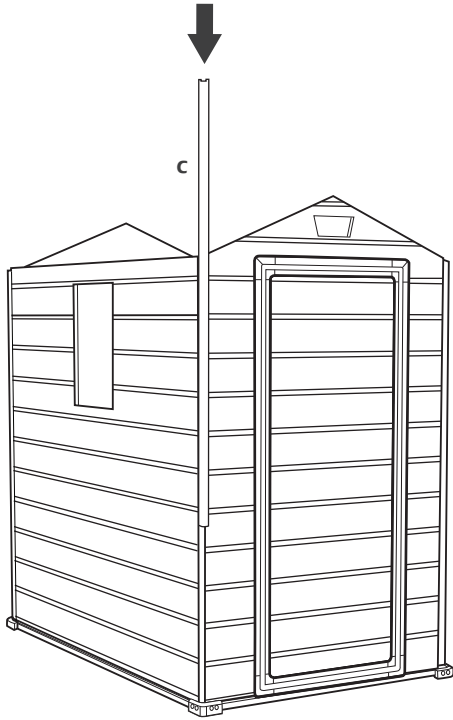

s26b (x8)  
26mm

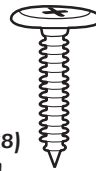

12

**IMPORTANT!**

Fully fit the panels inside the profiles.

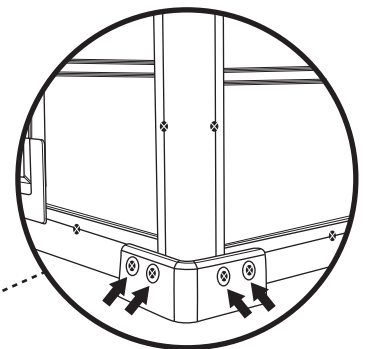
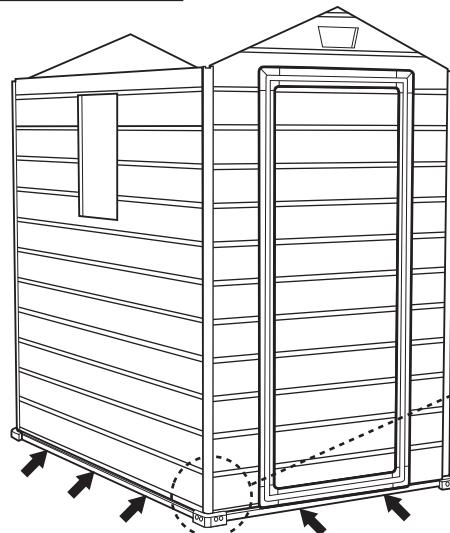
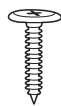
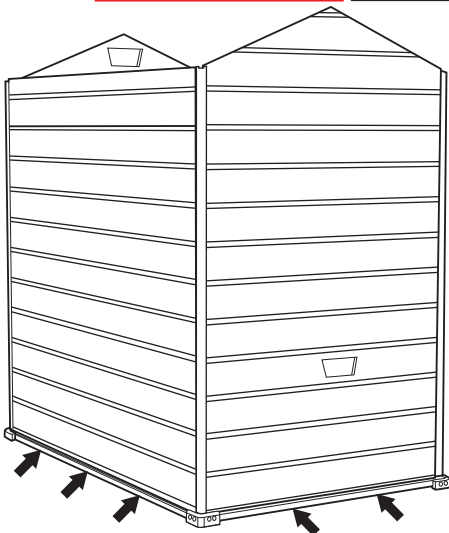
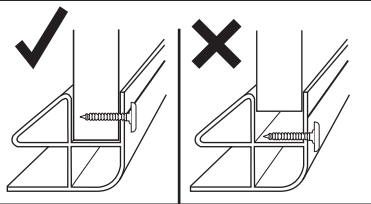

# ROOF ASSEMBLY

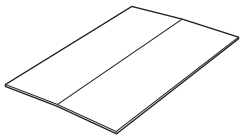
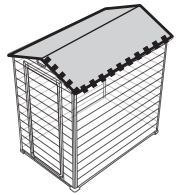

r (x1)

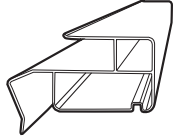

rc1 (x1) 1716mm

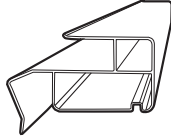

rc2 (x1) 585mm

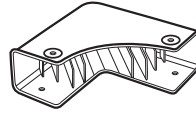

rc (x1)

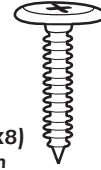

s26b (x8)  
26mm

# 13

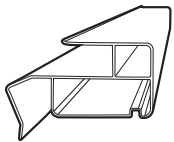
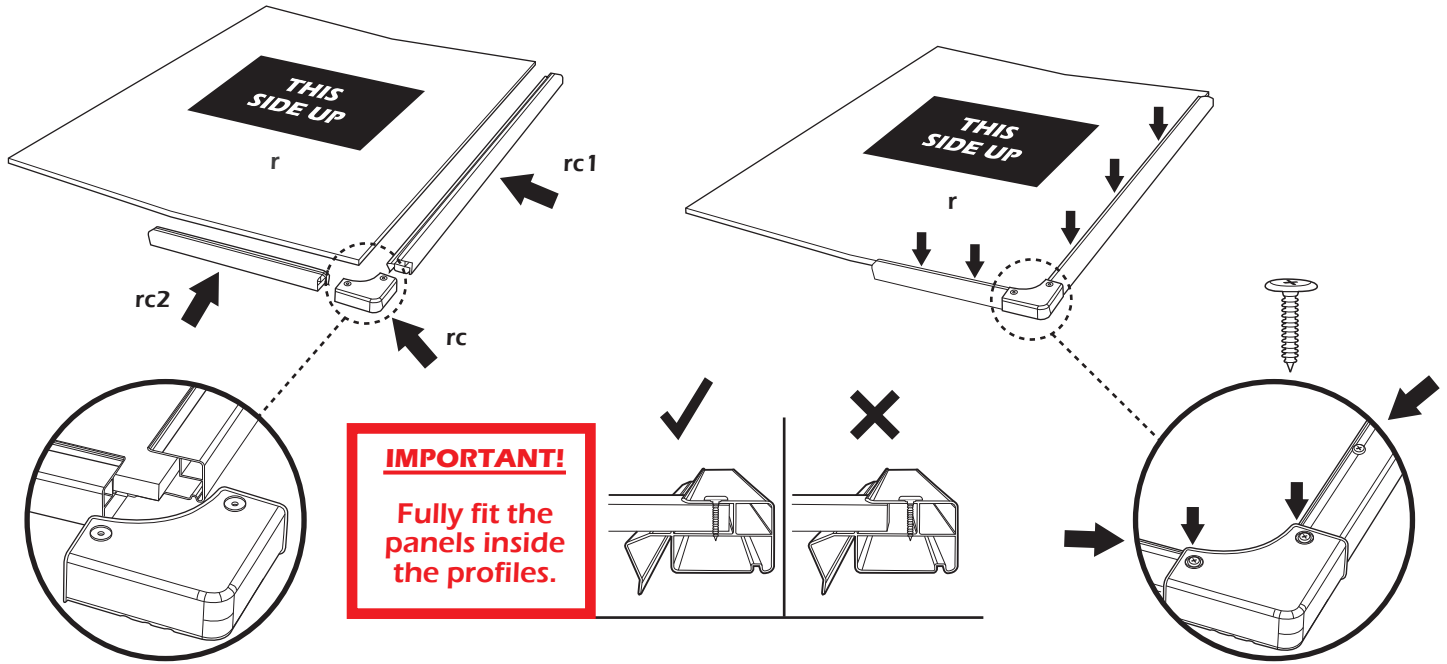

rc1 (x1) 1716mm

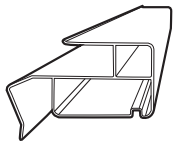

rc2 (x3) 585mm



rc (x3)

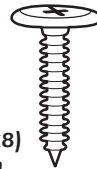

s26b (x8)  
26mm

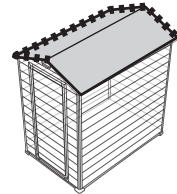

# 14

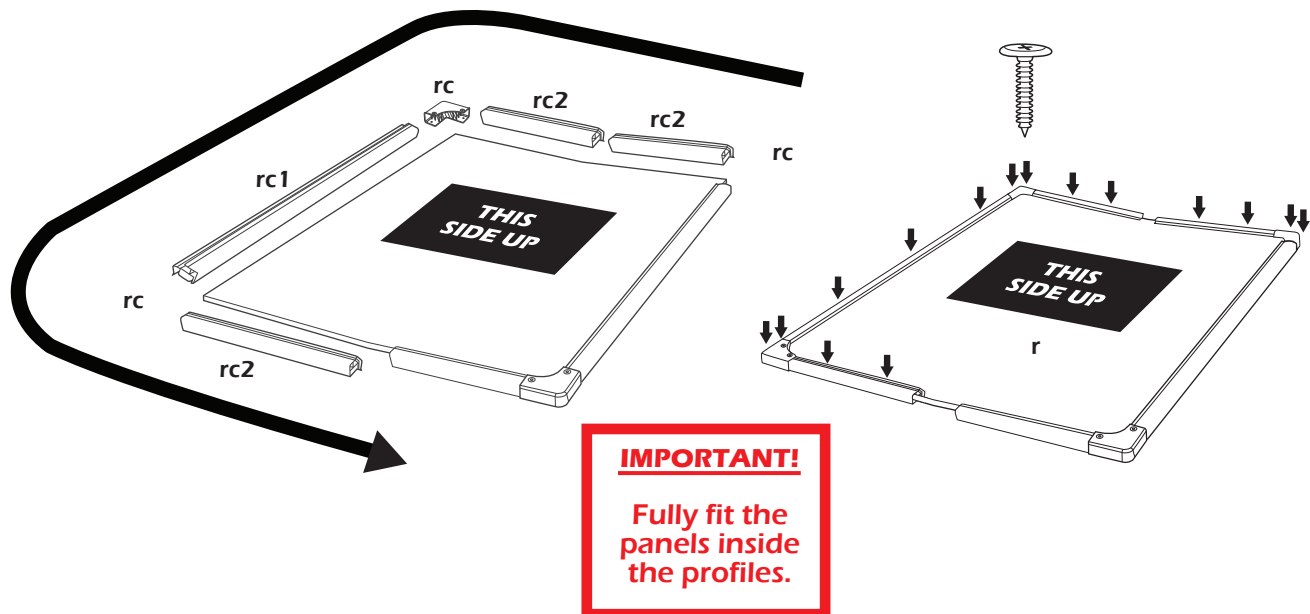

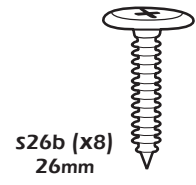
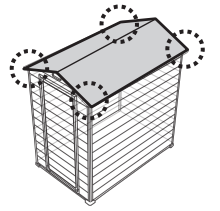

**15**

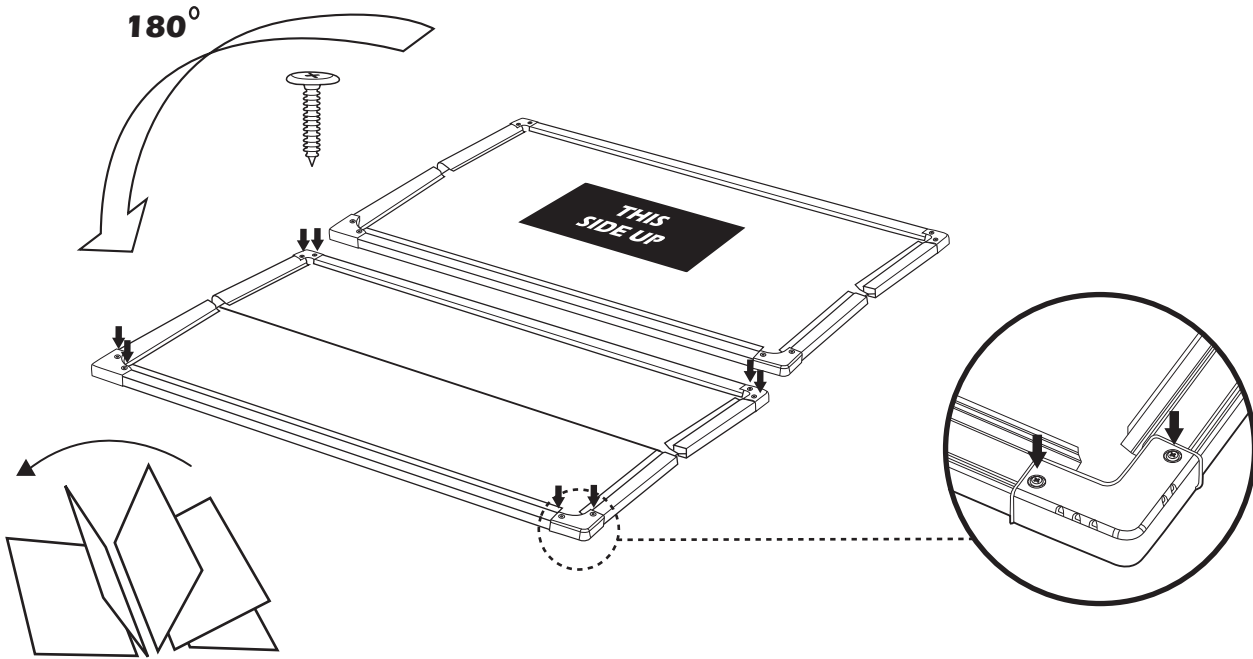

**16**

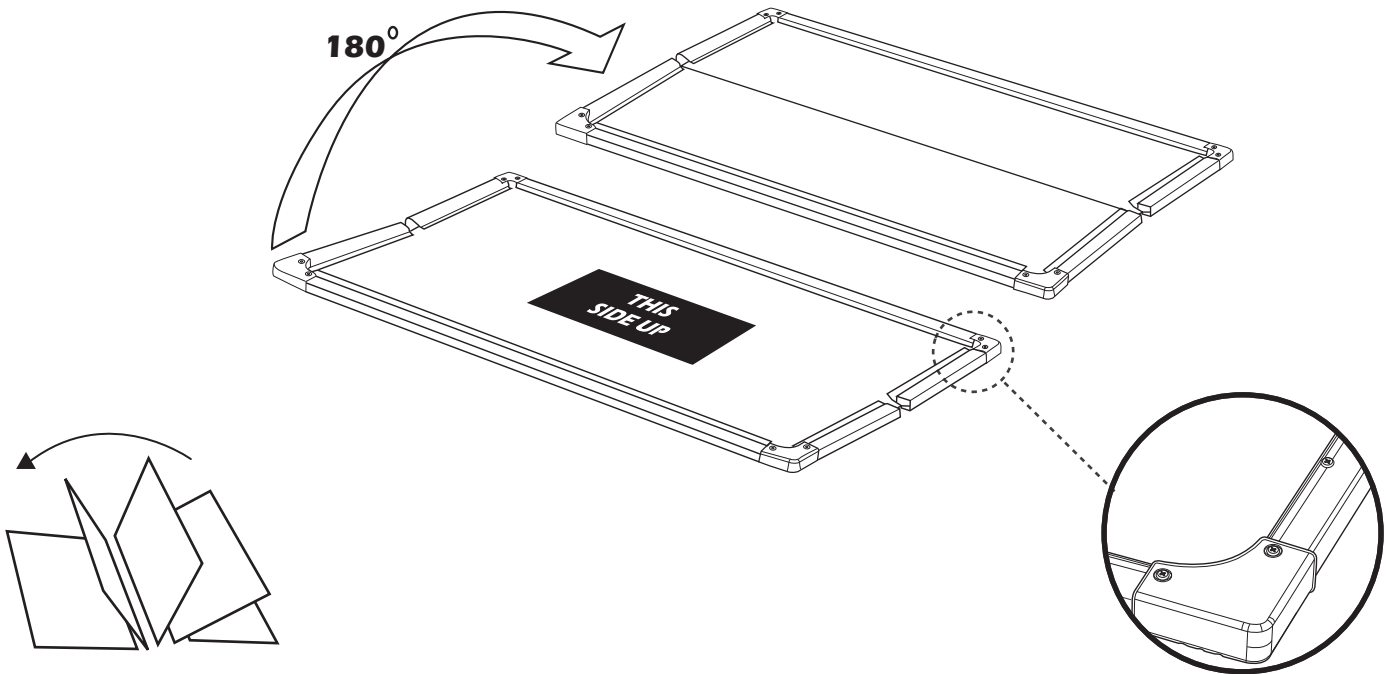

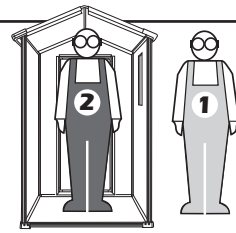

**17**

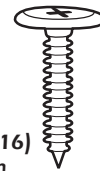
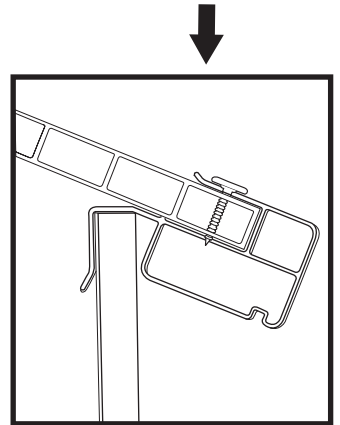
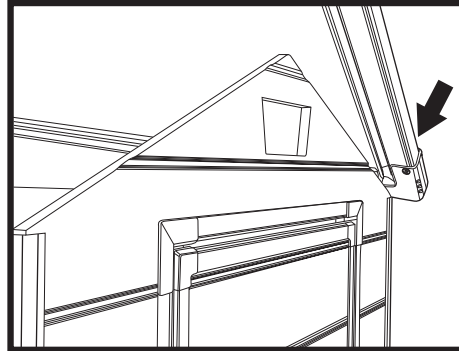
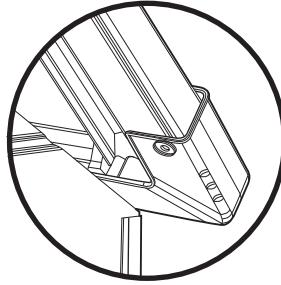
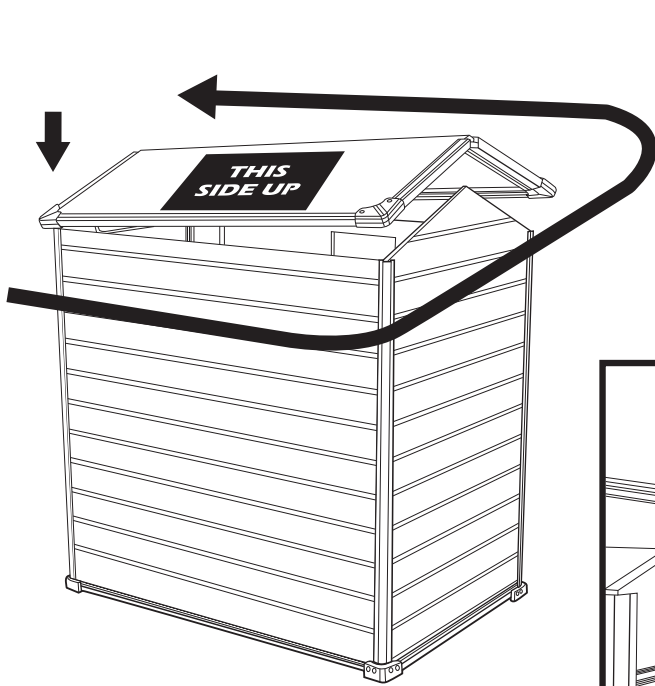

s26b (x16)  
26mm

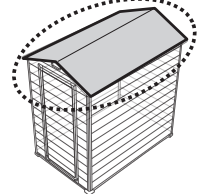

**18**

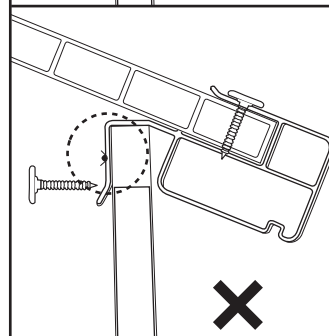
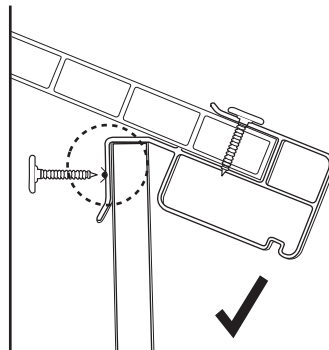
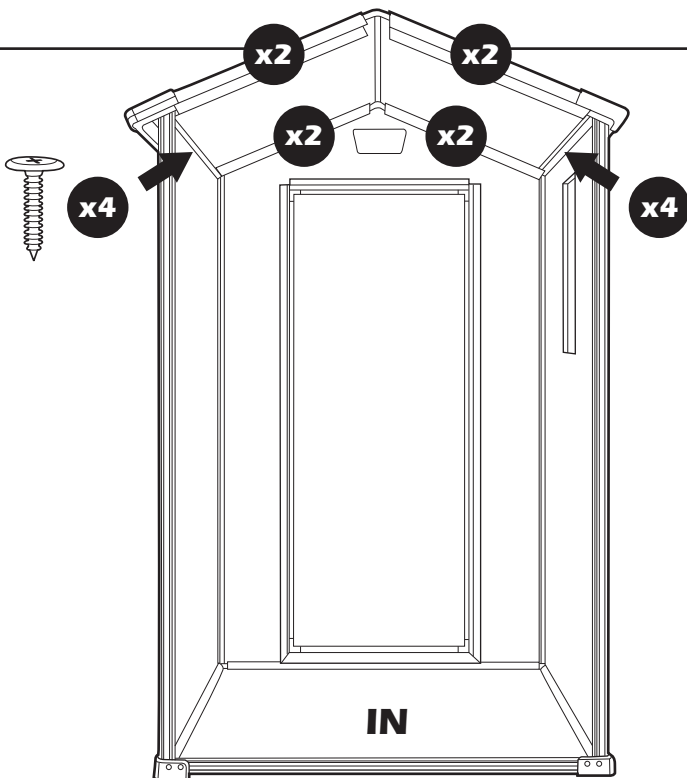

**IMPORTANT!**

Fully fit the panels inside the profiles.



k (x2)

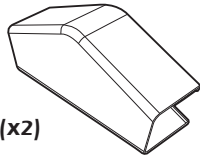

s26b (x4)  
26mm

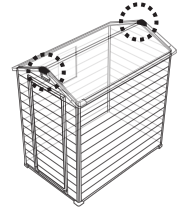
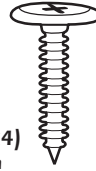

19

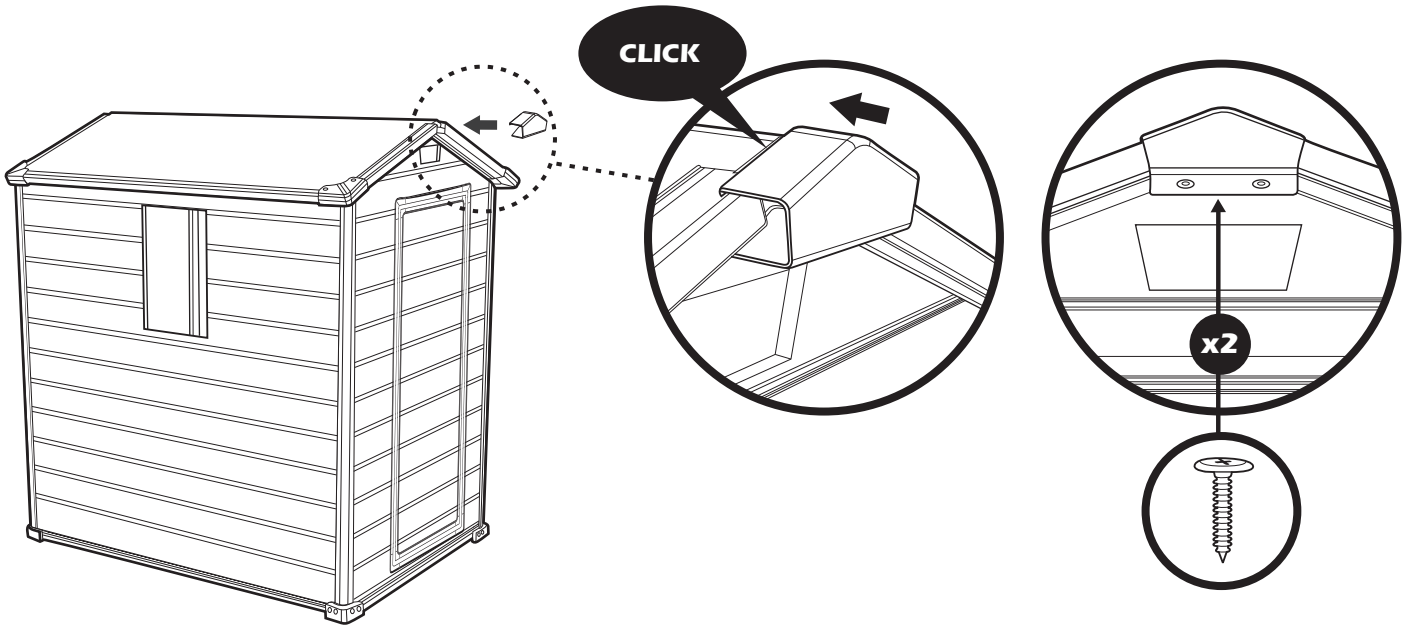

# VENT ASSEMBLY

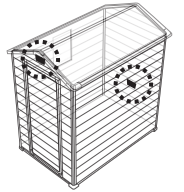

v (x2)

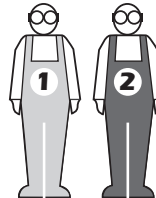
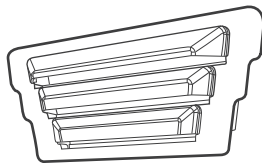

20

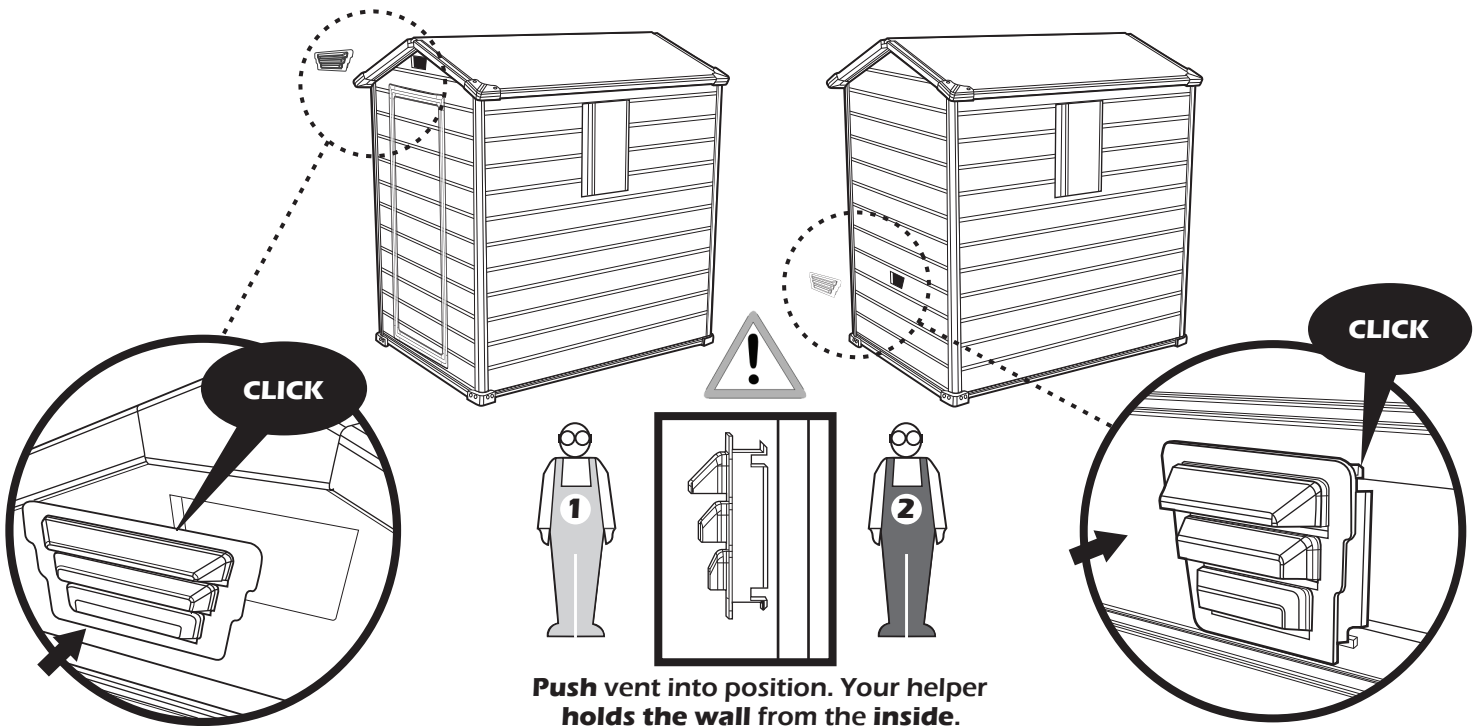

Push vent into position. Your helper holds the wall from the inside.

# WINDOW ASSEMBLY

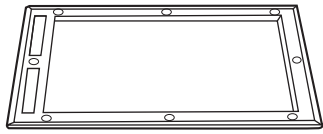
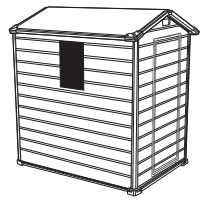

f-out (x1)

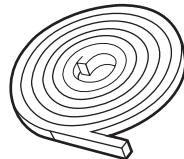

s (x1)

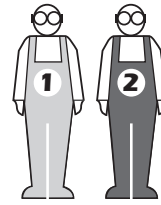

# 21

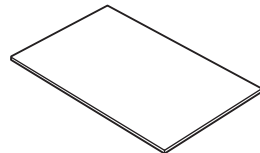
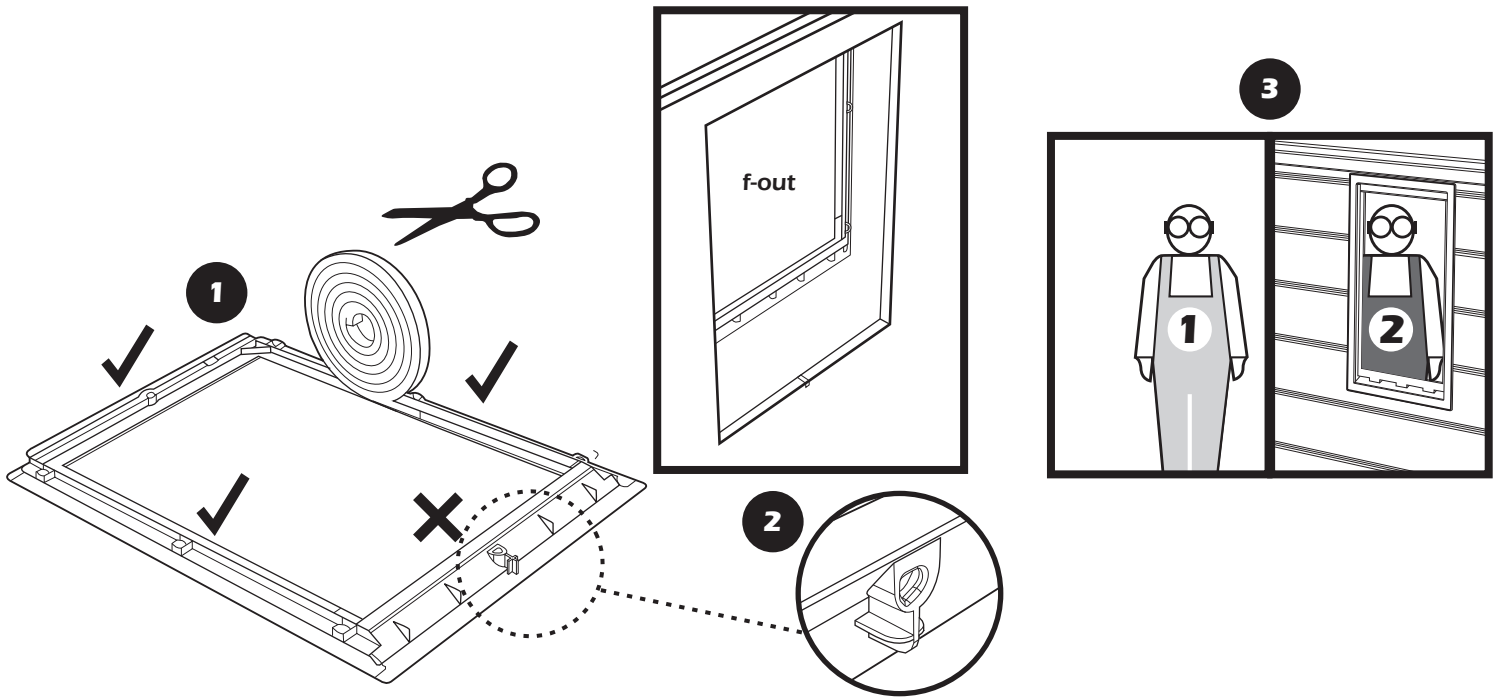

wt (x1)



# 22

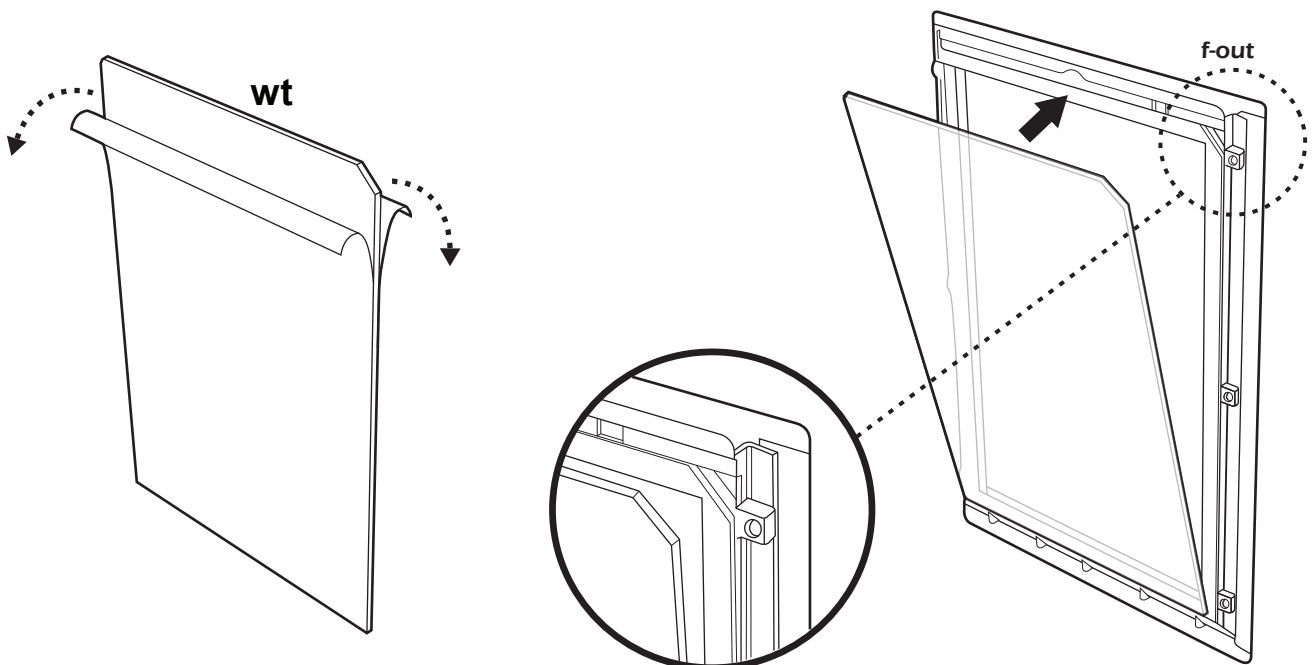

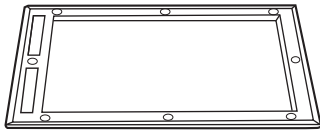

f-in (x1)

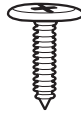

sc16 (x7)  
16mm

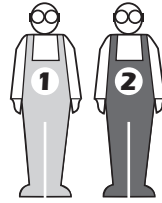

**23**

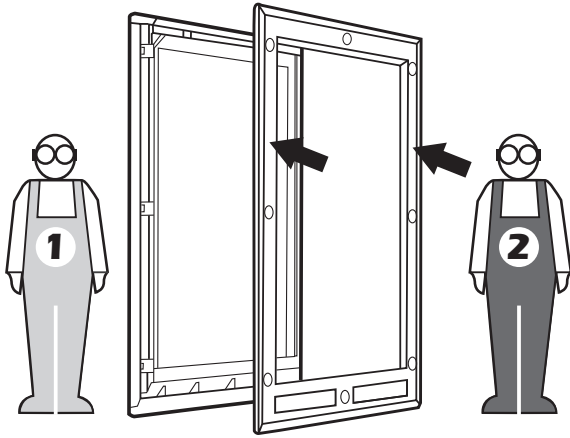

f-in

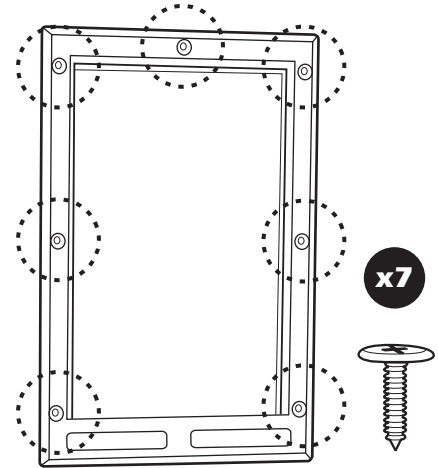

# FOUNDATION ATTACHMENT (Optional)

**24**

