

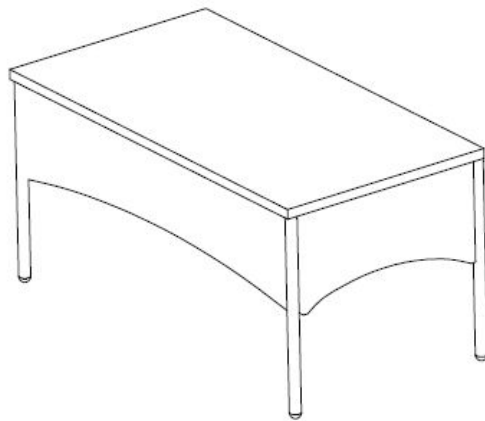

Assembly Instructions

Caution : You must read this before you proceed



Table

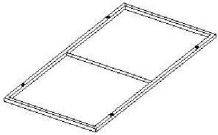
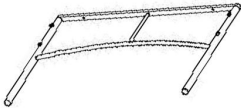

Parts List

Label	Picture	Description	QTY
I		Table Top	1
J		Long Side Panels with Leg	2
K		Short Side Panel	2





Hardware

Label	Picture	Description	QTY
L		Bolt(M6*25MM)	13
G		Washer	13

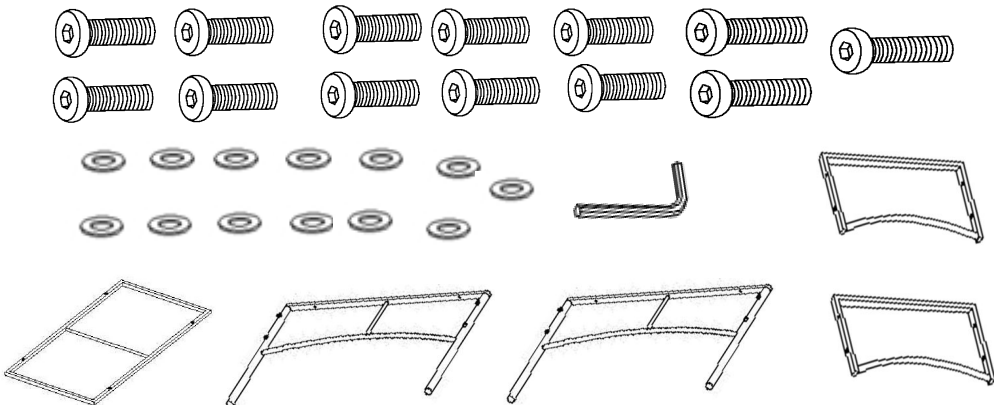
H		Allen Key	1
---	---	-----------	---

Assembly Preparation

<p>Before Beginning Assembly:</p>	
--	--

-  • Read instructions, cover to cover-
-  • Have 2 adults on hand for assembly-
-  • Do not assemble on flooring or carpet-
-  • Assemble on a clean non-marring surface (packing foam)-
-  • Save all packaging until finished-

Assembly Steps

Overview

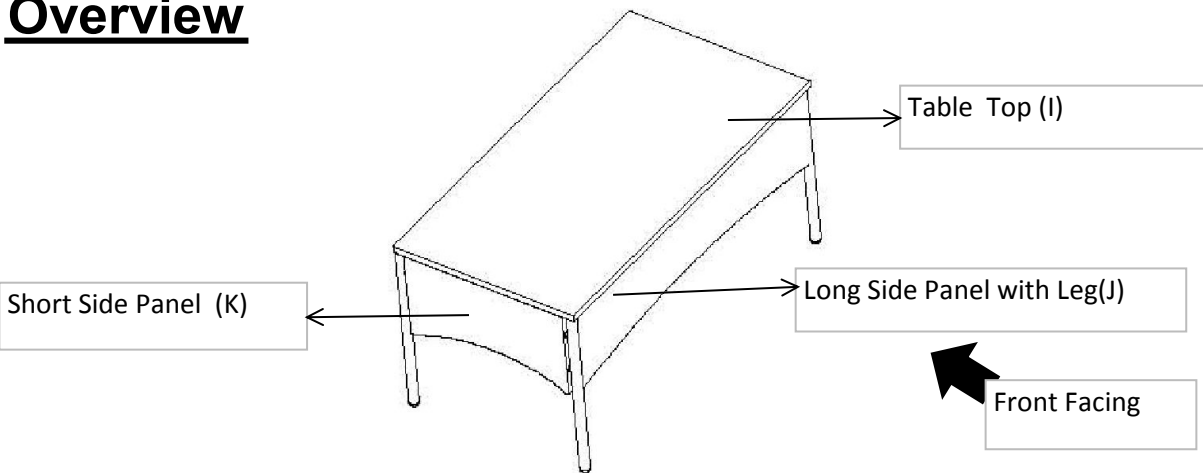

This Table has multiple parts and may require up to some 30 minutes to assemble. To give you an overview of the table parts, the above picture is to help you put the various parts into perspective. Please read through the instructions herebelow to familiarise yourself with the parts and steps before assembly.

Assembly Steps

Step 1

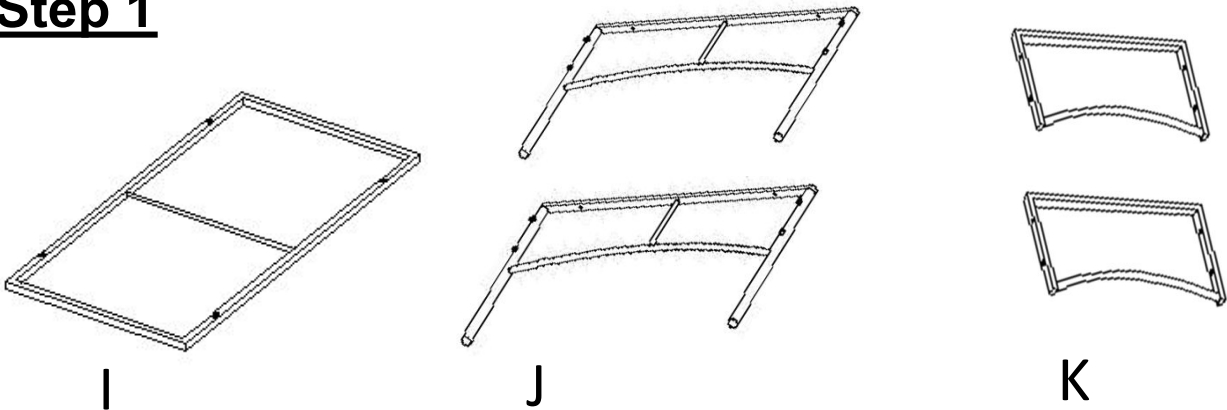

Open the carton and place all the parts onto a clean, non-marring surface.

Step 2

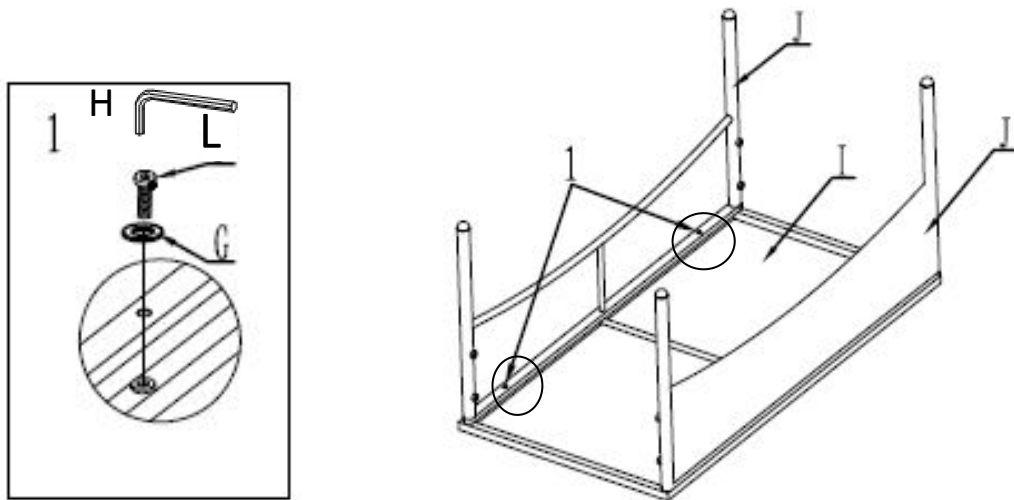

Place Table top (I) face down onto a clean, non-marring surface.

Attach the Long Side Panel with Leg(J) to Table Top(I) using Bolts(L) and Washers(G) with Allen Key(H)

Repeat the same process to assemble the other Long Side Panel with Legs(J).

Only loosely tighten Bolts.

Occasionally some of the PE Wicker shifts and covers the mounting positions preventing easy assembly. The PE wicker should never be cut, but moved away from the mounting positions.

Step 3

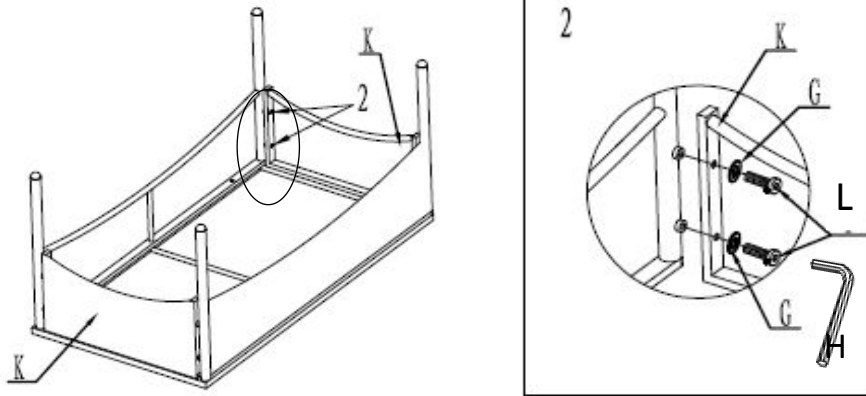

Attach the Short Side Panel(K) between to the Long Side Panel with Legs(J), using Bolts(L) and Washers(G) with Allen Key(H).

Repeat the same process to assemble the other Short Side Panel(K).

Only loosely tighten Bolts.

Step 4

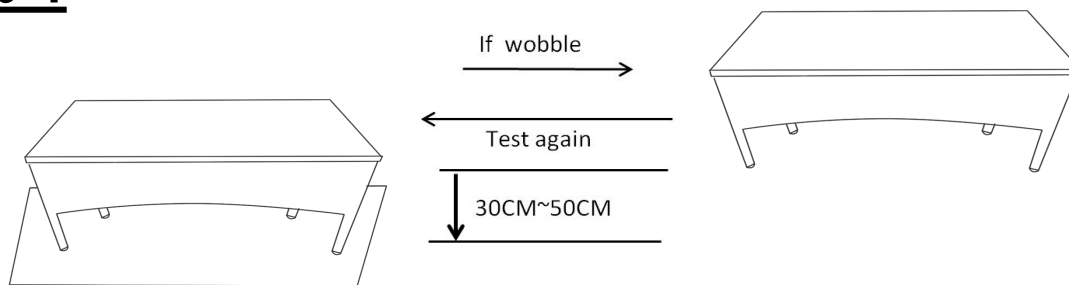

Place the Table on a **LEVEL SURFACE** to see if it wobbles.

If it wobbles, lift the Table to some 30cm to 50cm height from the ground.

Keep your feet and toes well away from the drop zone.

Drop the Table freely and vertically with the four legs, hitting the ground, at the same time.

This Drop Test will help to ensure that all the Bolts and gaps will all reach full alignment status.

Test again for evenness on a **LEVEL SURFACE**.

If no wobbles are found, lay down the Table down and proceed to tighten all the Bolts.

When tightening these Bolts, tighten sequentially.

DO NOT tighten any Bolt fully and then move on to the next one.

This may cause the frame to warp.

If there are still wobbles, loosen the Bolts and execute this same drop test.

If the Table is not stable it could lead to damage to the product.

Step 5

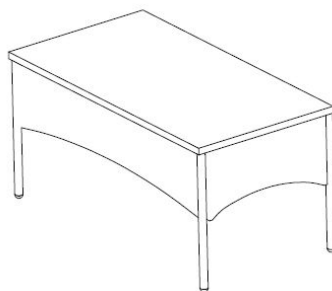

Your table is ready for use.

Care & Maintenance



- Do not put hot items directly on furniture surface.



- Do not clean furniture with harsh cleansers or polish.



- To obtain the longest lifespan of your outdoor products, minimizing exposure to direct sunlight is recommended.



- Children should not climb or jump on the furniture.



- Do not write on furniture without a padded barrier to protect the surface.



- To obtain the longest lifespan of your outdoor products, avoid extended and lengthy exposure to rain, snow, and direct sunshine. Whenever possible cover the product and /or place under patio or awnings.



- Not for commercial use. For residential use only .



- Stains may be removed with mild soap solution and damp cloth.



- Keep away from sources of ignition.



- Dust and pick-up spills using a clean, non-colored, lint-free cloth .



Assembly Instructions

Caution : You must read this before you proceed

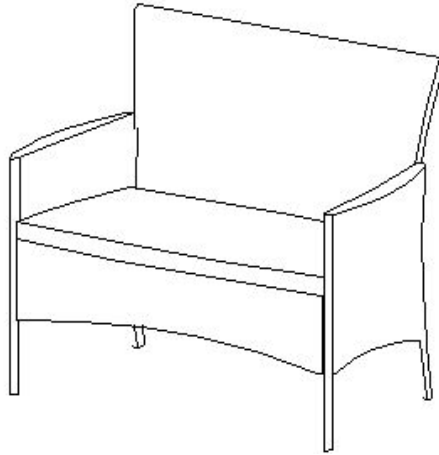

Loveseat

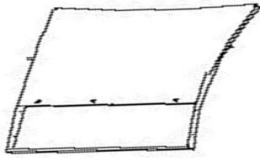
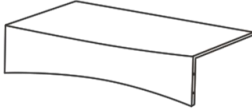
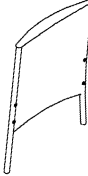
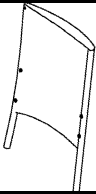

Parts List

Label	Picture	Description	QTY
A		Backrest	1
B		Seat	1
C		Right Armrest With Leg	1
D		Left Armrest With Leg	1
E		Seat Cushion	1

Hardware

Label	Picture	Description	QTY
F		Bolt(M6*35MM)	12
G		Washer	12
H		Allen Key	1

Assembly Preparation

Before Beginning Assembly:

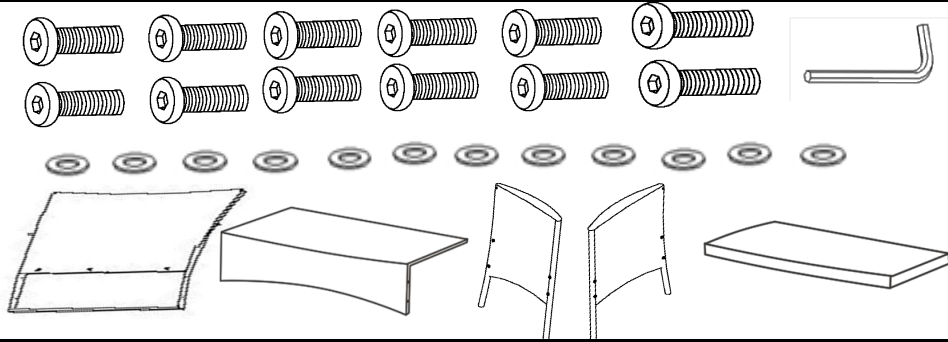

- Read instructions, cover to cover-



- Have 2 adults on hand for assembly-



- Do not assemble on flooring or carpet-



- Assemble on a clean non-marring surface (packing foam)-



- Save all packaging until finished-

Assembly Steps

Overview

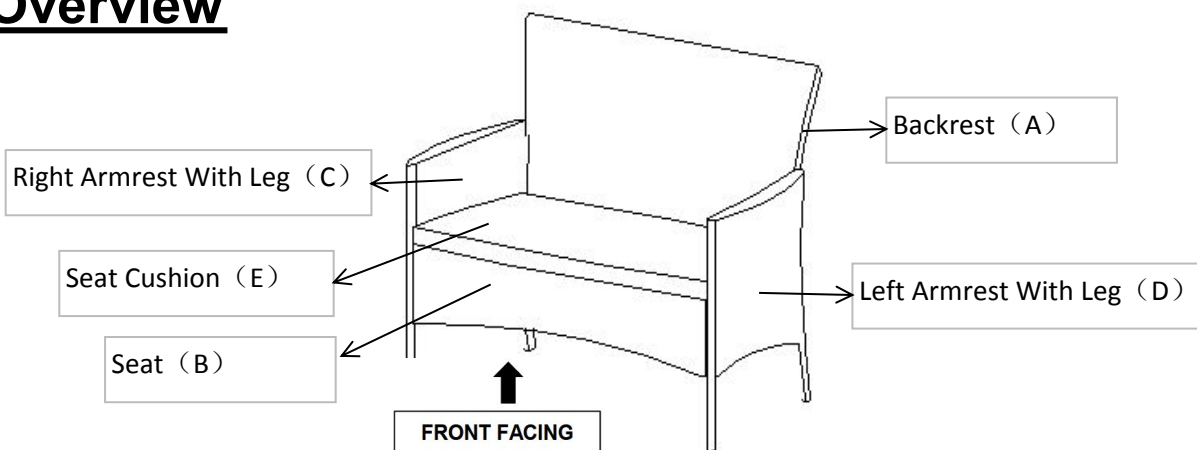

This Loveseat has multiple parts and may require up to an hour minutes to assemble. To give you an overview of the Loveseat parts, the above picture is to help you put the various parts into perspective. Please read through the instructions herebelow to familiarise yourself with the parts and steps before assembly.

Assembly Steps

Step 1

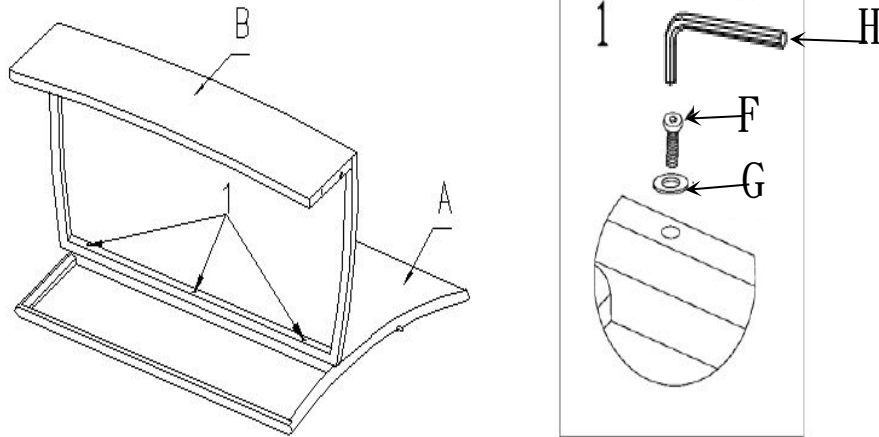

Open the carton and place all the parts onto a clean, non-marring surface.
Place the Backrest(A) with its inside facing skywards.
Attach Seat(B) to Backrest(A) using Bolts(F) and Washers(G) with Allen Key(H).
Only loosely tighten Bolts.

Occasionally some of the PE Wicker shifts and covers the mounting positions preventing easy assembly. The PE wicker should never be cut, but moved away from the mounting positions.

Step 2

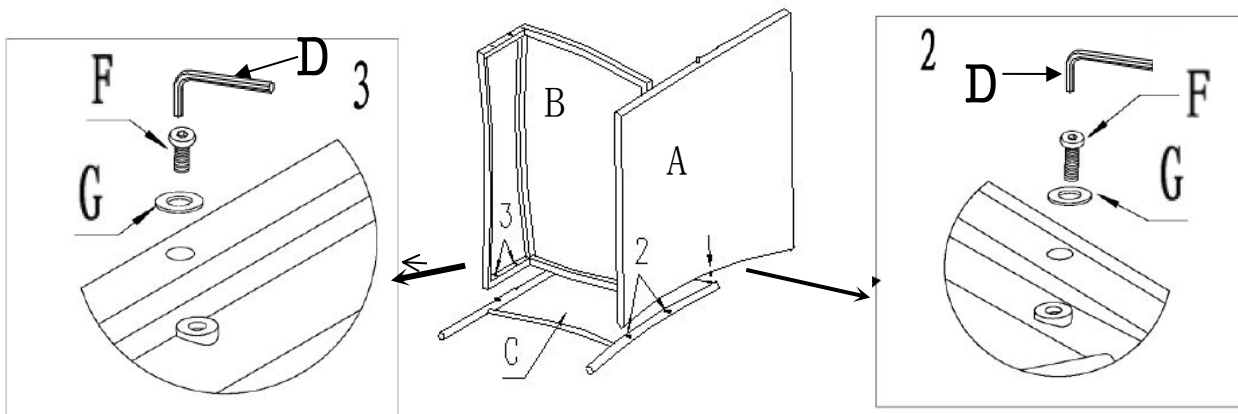

Place the Right Armrest With Leg(C), as pictured above.
Attach Right Armrest With Leg(C) to the Backrest (A) and Seat(B) using Bolts(F) and Washers(G) with Allen Key(H).
Only loosely tighten Bolts.

Step 3

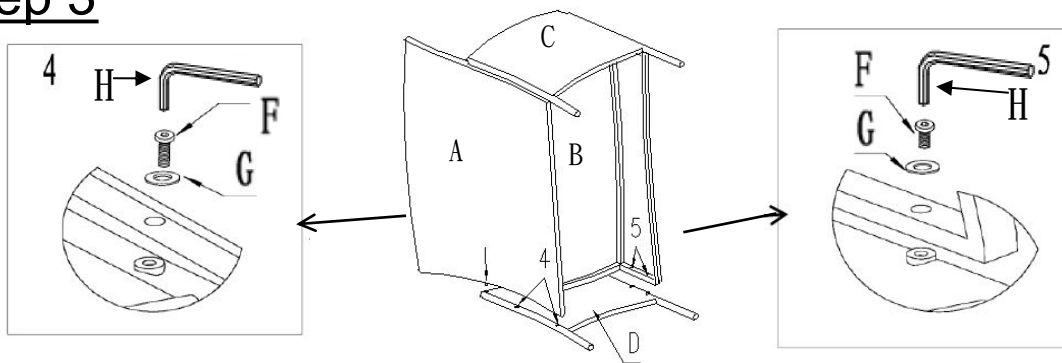

Place the Left Armrest With Leg(D) as pictured above.
Attach Left Armrest With Leg(D) to the Backrest(A) and Seat(B) using Bolts(F) and Washers(G) with Allen Key(H).

Only loosely tighten Bolts.

Step 4

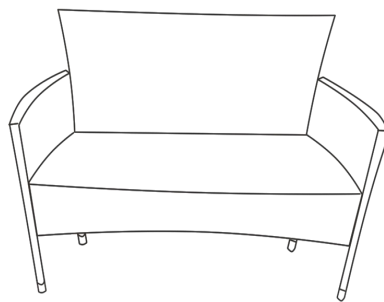

Turn the Loveseat right side up.
Place the Loveseat on a **LEVEL SURFACE**.
Inspect it and make sure all parts are adequately connected.
Gently and gracefully, sit into to the Loveseat.
This would help to align all the parts at all the joint areas.
Then get off the Loveseat, with assistance from your adult partner, turn the Sofa over.
In a sequential manner, proceed to **tighten all bolts**.

When tightening the Bolts, tighten sequentially.
DO NOT tighten any Bolt fully and then move on to the next one.
This may cause the frame to warp.
If there is still wobbles, loosen the bolts and execute this same process.
If the Loveseat is not stable it could lead to damage to the product.

Step 5

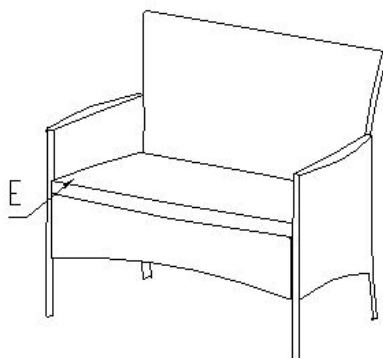

Put the Seat Cushion(E) on the Seat.
Your Loveseat is ready for use.

Care & Maintenance



- Do not put hot items directly on furniture surface.



- Do not clean furniture with harsh cleansers or polish.



- To obtain the longest lifespan of your outdoor products, minimizing exposure to direct sunlight is recommended.



- Children should not climb or jump on the furniture.



- Do not write on furniture without a padded barrier to protect the surface.



- To obtain the longest lifespan of your outdoor products, avoid extended and lengthy exposure to rain, snow, and direct sunshine. Whenever possible cover the product and /or place under patio or awnings.



- Not for commercial use. For residential use only .



- Stains may be removed with mild soap solution and damp cloth.



- Keep away from sources of ignition.



- Dust and pick-up spills using a clean, non-colored, lint-free cloth .