

Combination Cedar Bench

8' and 4' Extender Instructions

#16650

-BEFORE YOU BEGIN-

■ First...

Read these instructions thoroughly before you begin assembly. Assembly is easiest if you follow the steps in the order shown.

In a drawing, a dotted line represents a part hidden from view (like a part under a panel).

Lumber is graded from only one side. Check the part for the most attractive face and make sure to face it to the outside.

■ Check all parts

Compare the parts you have to the list. If a part is missing, circle the part in question and call our toll-free # at 1-888-827-9056

Always wear OSHA-APPROVED safety glasses throughout the assembly process

■ Tools Required

- Hammer
- Phillips Screwdriver
- Level
- Pencil
- Tape Measure

■ Optional Tools

- Electric Drill with #2 phillips Tip
- Square
- Nail Pouch

Parts List

Qty.	Description	Standard	Metric
Standard Bench			
<input type="checkbox"/> 1	-- Front Trim	1x6x85 ¹ / ₂ "	2x14x217cm
<input type="checkbox"/> 1	-- Main Support	2x4x85 ¹ / ₂ "	4x9x217cm
<input type="checkbox"/> 1	-- Bench Brackets	24-1/2x16"	61x41cm
<input type="checkbox"/> 1	-- Supports	2x4x31 ¹ / ₂ "	4x9x80cm
<input type="checkbox"/> 16	-- Top Slats	1"x6x35"	2.5x14x89cm
<input type="checkbox"/> 2	-- Metal Support Connector		
<input type="checkbox"/> 1	-- Hardware Kit		
		1 ¹ / ₂ " (7.6cm) Nails	
		2" (5cm) Finish Nails	
		3" (7.6cm) Screws	
		1 ¹ / ₄ " (3.2cm) Screws	

Extender Bench

<input type="checkbox"/> 1	-- Front Trim	1x6x45 ¹ / ₂ "	2.5x14x115.5cm
<input type="checkbox"/> 1	-- Main Support	2x4x45 ¹ / ₂ "	4x9x115.5cm
<input type="checkbox"/> 1	-- Bench Brackets	24-1/2x16"	61x41cm
<input type="checkbox"/> 1	-- Supports	2x4x31 ¹ / ₂ "	4x9x80cm
<input type="checkbox"/> 8	-- Top Slats	1"x6x35"	2.5x14x89cm
<input type="checkbox"/> 1	-- Hardware Kit		
		2" (5cm) Finish Nails	
		3" (7.6cm) Screws	
		1 ¹ / ₄ " (3.2cm) Screws	

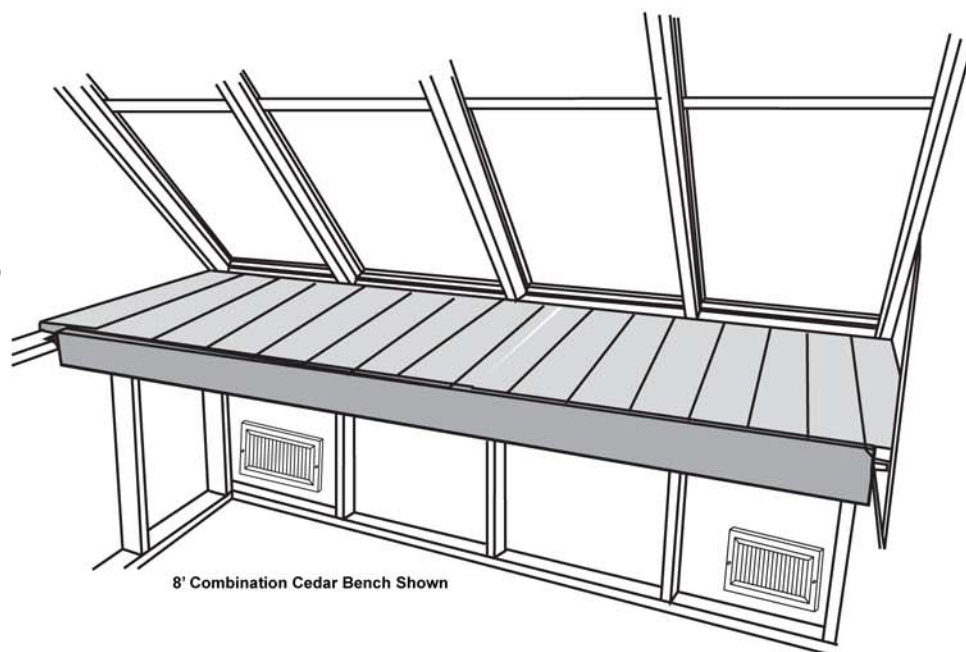

8' Combination Cedar Bench Shown

1A. 8', 12' and 16' Bench Model

Attach 2x4x31-1/2" board and Bench Bracket as shown. Attach with (4) 1-1/4" screws. Make 1 assembly for 8' bench, 2 assemblies for 12' bench and 3 assemblies for 16' bench model.

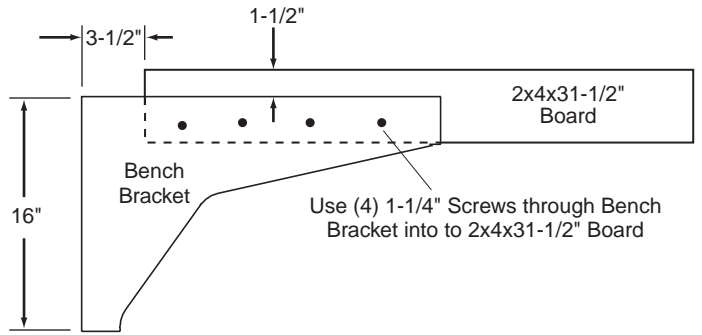

1B. 8' Bench

Attach Metal Support Connectors to both ends of Main support 2x4x85-1/2" using two 1 1/2" (2.5cm) nails on each end.

1C. 12' Bench

Attach Metal Support Connectors to one end of Main support 2x4x85-1/2" and one end of extender support 2x4x45-1/2" using two 1 1/2" (2.5cm) nails on each end.

1D. 16' Bench Model

Attach Metal Support Connectors to one end of Main support 2x4x85-1/2" and one end of extender support 2x4x45-1/2" using two 1 1/2" (2.5cm) nails on each end. (See Drawing 1D)

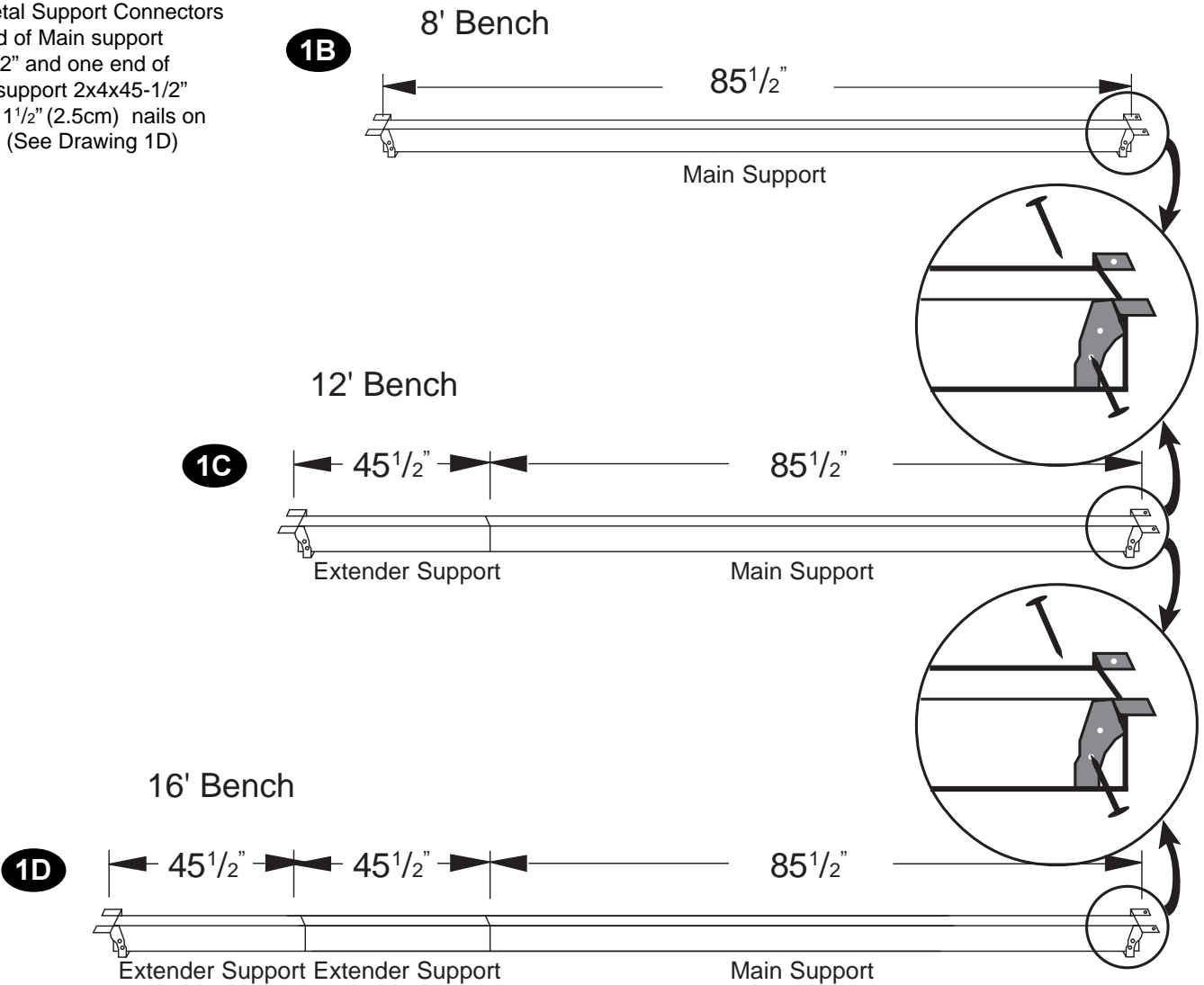

**FOR 12' AND 16' BENCH,
CONTINUE ON PAGE 4.**

1E. 8' Bench

Attach bench bracket to center wall stud with (4) 1-1/4" Screws. Keep the 2x4x31-1/2" board flush to the top of the Small Wall Top Plate. Attach Main Support to the end of 2x4x31-1/2" board with (2) 3" screws. Maintain 31-1/2" dimension and attach main support ends to SN, Side Wall Top Plate, through metal bracket with (2) 1-1/2" nails.

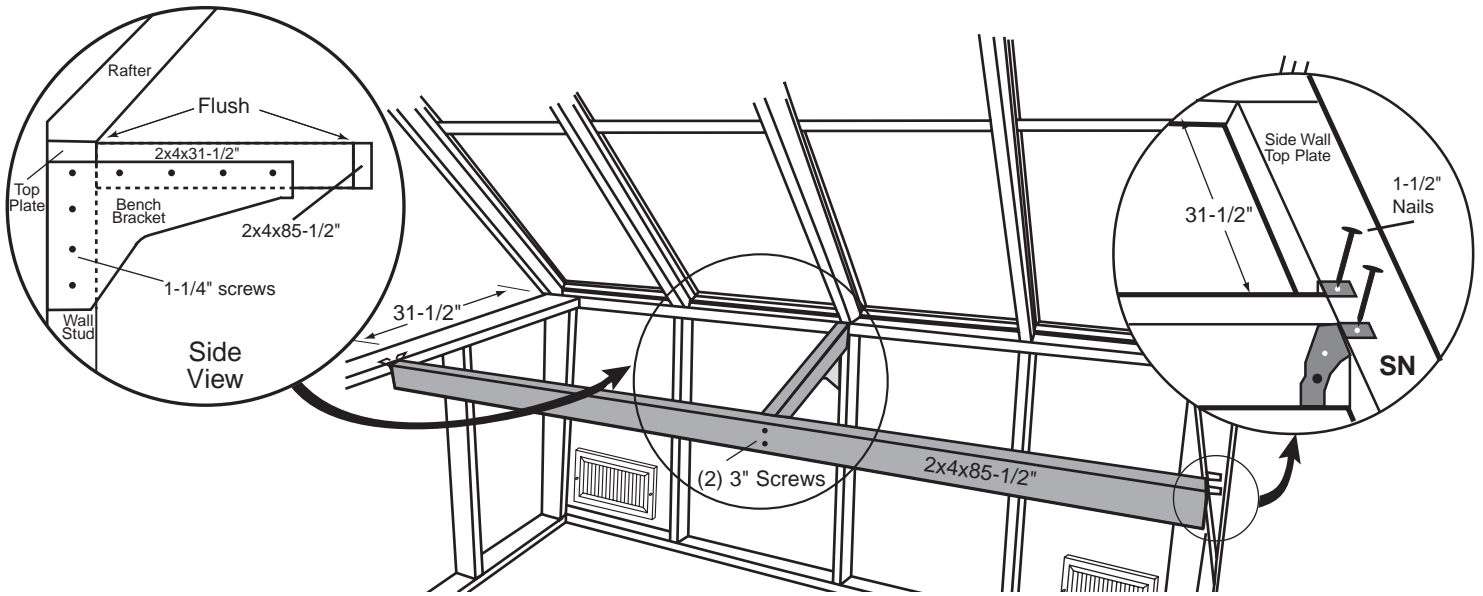

1F. 8' Bench

Attach Front Cedar Trim 1x6x85-1/2" to the front with (12) 2" Finish Nails. Keep up 1" from 2x4x85-1/2" support.

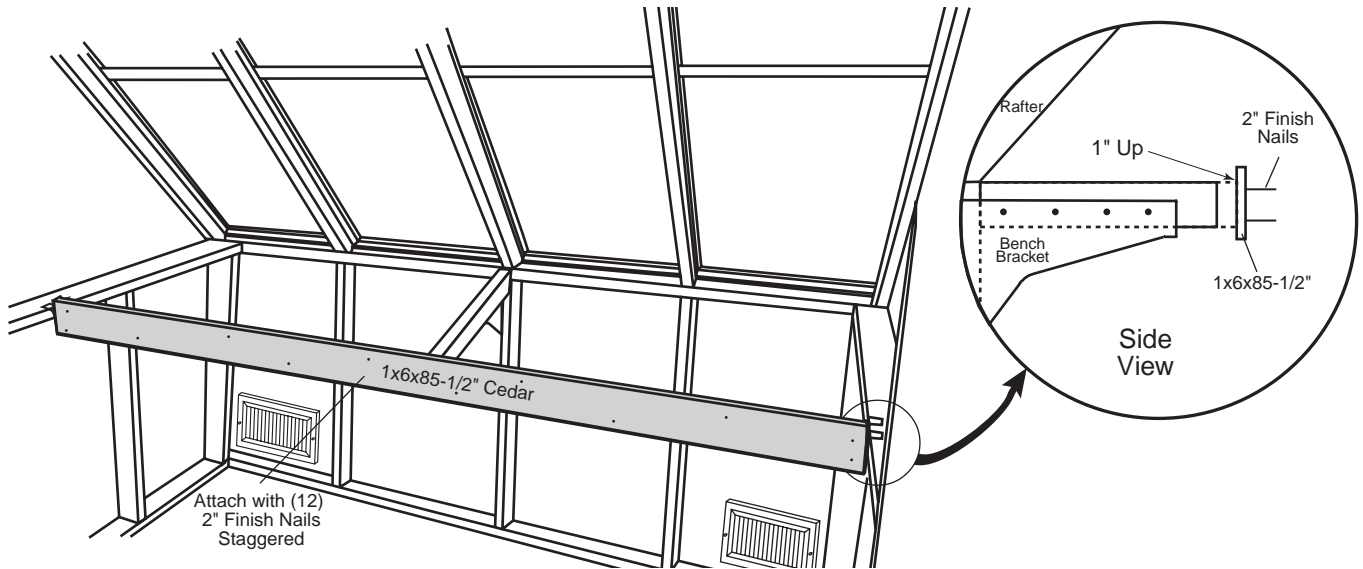

1G. 8' Bench

Place Top Slats 1x6x35" for the top of the cedar bench loose. Keep crown side up and evenly spaced..

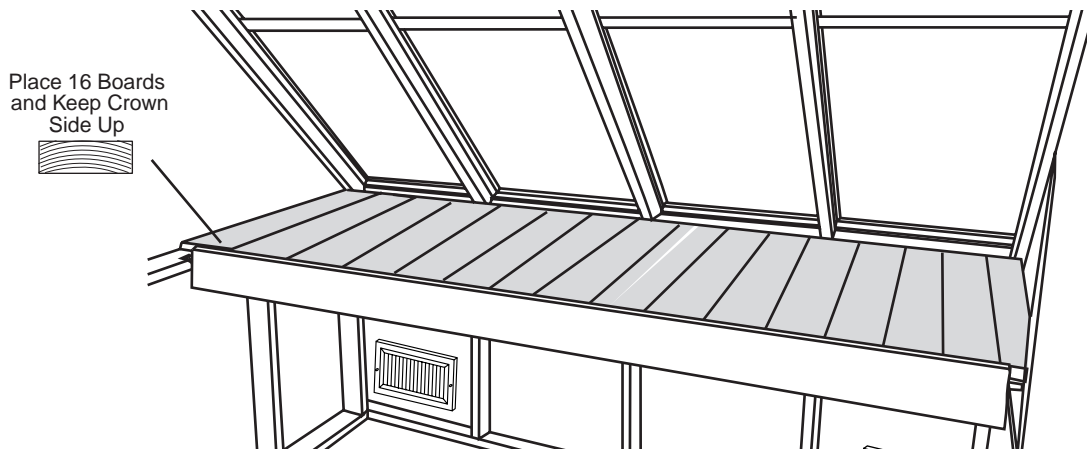

1H. 12' Bench and 16' Models

Attach bench brackets to 2nd and 4th wall stud (and 6th for 16' Models) with (4) 1-1/4" Screws. Keep the 2x4x31-1/2" board flush to the top of the Small Wall Top Plate. Attach Main Support 2x4x85-1/2" to the end of 2x4x31-1/2" board with (2) 3" screws and 2x4x45-1/2" to other 2x4x31-1/2" board. Maintain 31-1/2" dimension and attach main support ends to SN, Side Wall Top Plate, through metal bracket with 1-1/2" nails. (Repeat for 16' Models)

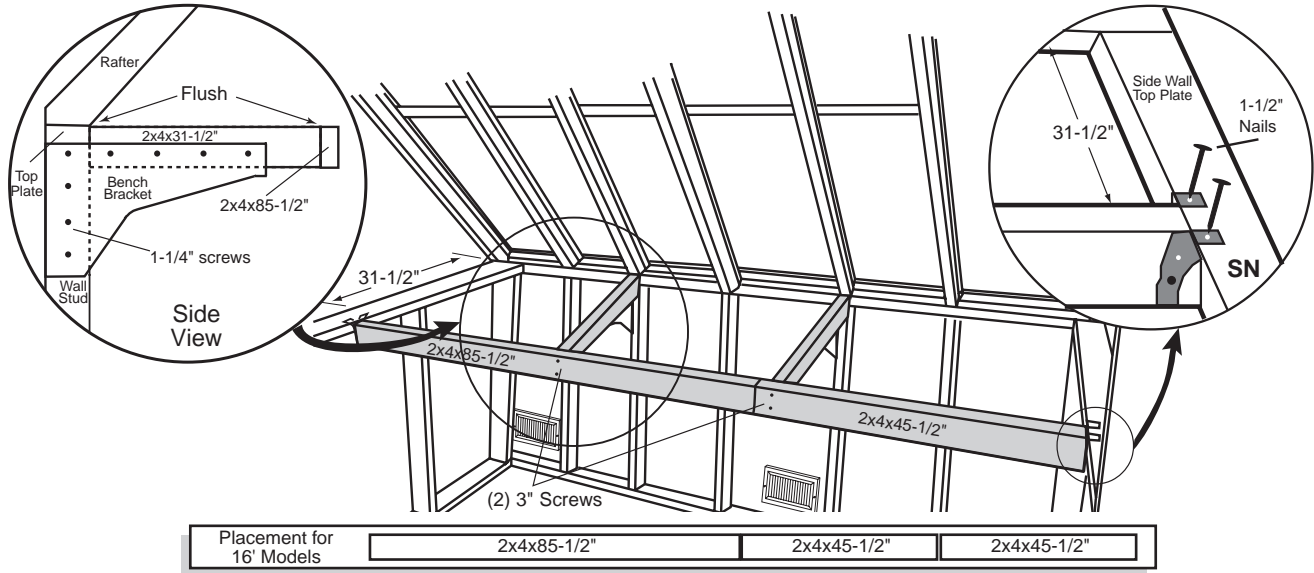

1I. 12' Bench and 16' Models

Attach 1x6x85-1/2" Front Trim to the front with (12) 2" Finish Nails overlapping 2x4x85-1/2" seam. Attach 1x6x45-1/2" board with 2" finish nails in place. Keep up 1" from 2x4x85-1/2" and 2x4x45-1/2" support.

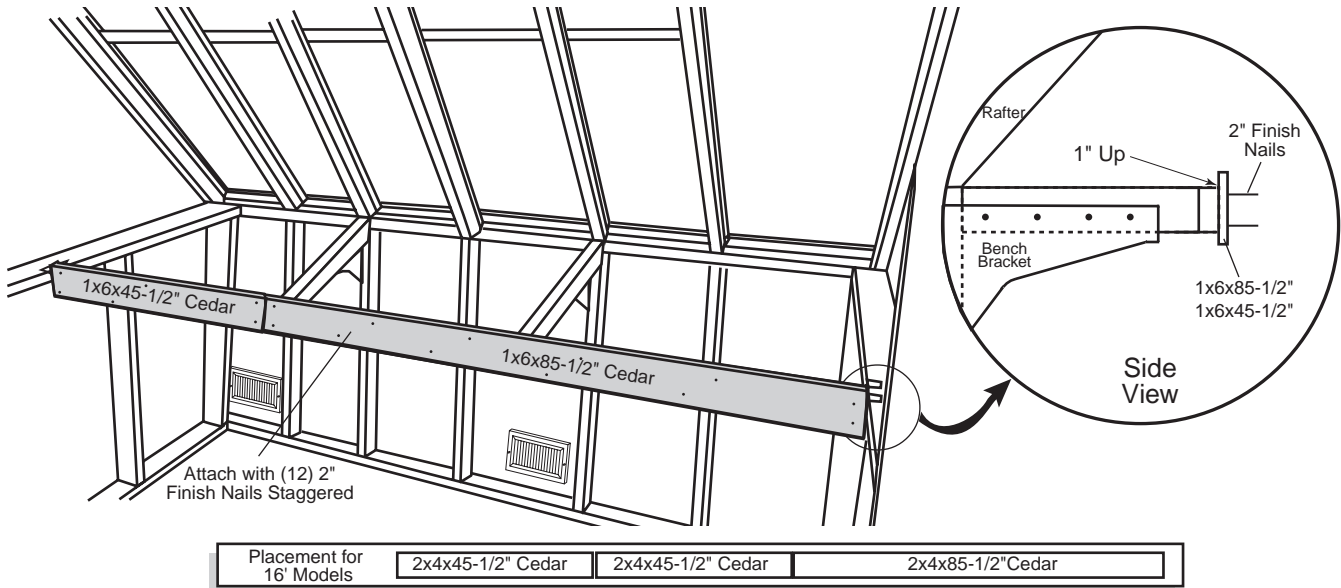

1J. 12' Bench and 16' Model

Place Top Slats 1x6x35" for the top of the cedar bench loose. Keep crown side up and evenly spaced.

