

Model: CLC23

- (1) Seat assembly
- (1) Back assembly
- (2) Sideframes
- (1) Top back rail
- (1) Seat support
- (1) Seat cushion
- (1) Back cushion
- (1) Hardware pack

Step 1

- Attach seat support to seat assembly using (2) 3" chair screws
- Attach back assembly to seat assembly using (2) 3" chair screws

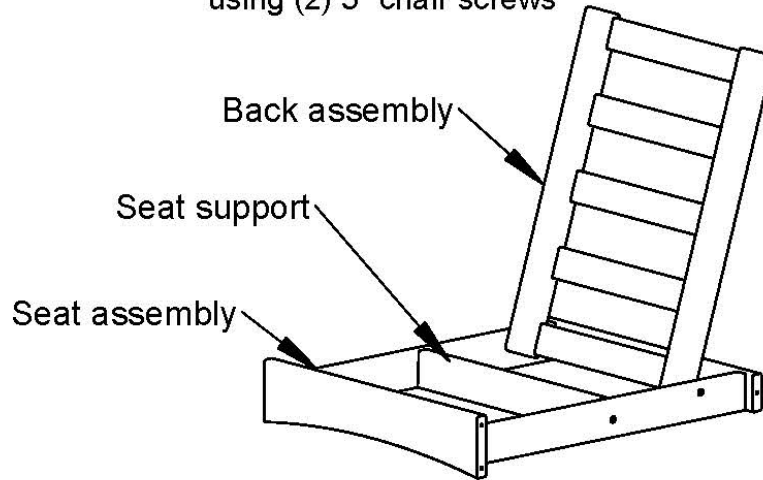

Step 2

- Lay the seat assembly on its side.
- Attach sideframe using (3) 3" chair screws

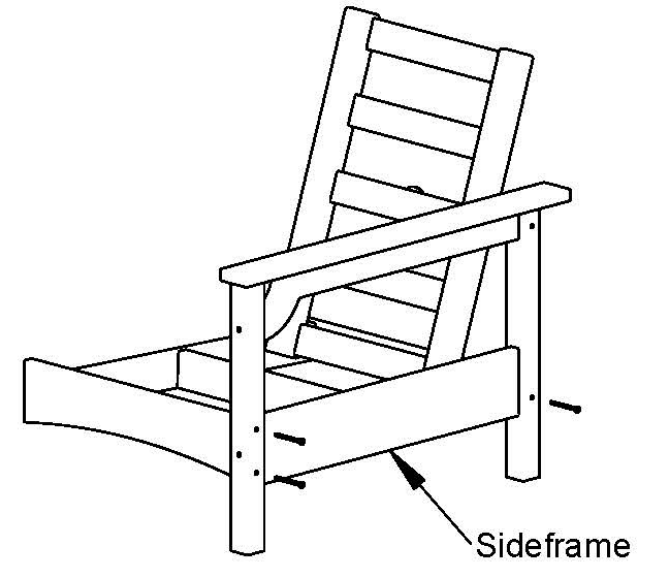

Step 3

- Repeat Step 2 on other side.

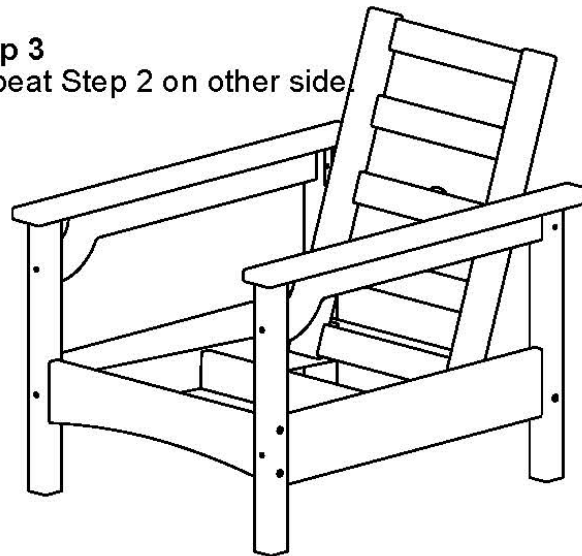

Step 4

- Attach top back rail to sideframes using (2) 3" chair screws
- Insert seat and back cushions

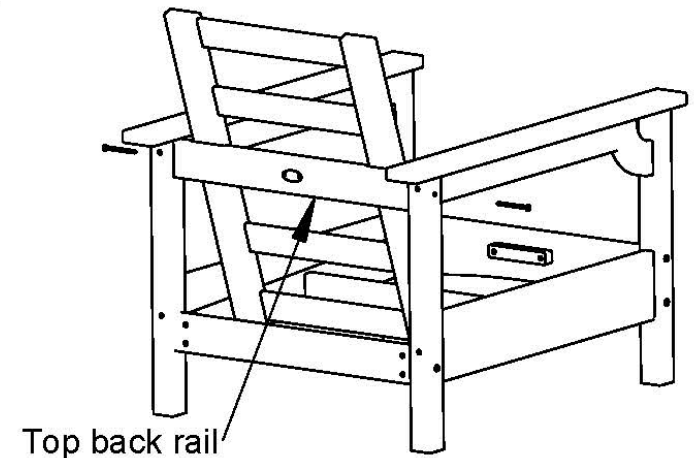

TOOLS NEEDED



Qty.	Description
12	A - .27 X 3 SOCKET WAFER A





Assembly Instructions
Model: CLC47 & CMC47
 *CLC47 shown

- ___ (2) Seat assembly
- ___ (2) Back assembly
- ___ (2) Seat support
- ___ (2) Top rails
Right, Left
- ___ (2) Sideframes
- ___ (1) Front mid leg
- ___ (1) Rear mid leg
- ___ (2) Seat cushion
- ___ (2) Back cushion
- ___ (1) Hardware pack

Step 1

- Attach seat support to seat assembly using (2) 3" chair screws
- Attach back assembly to seat assembly using (2) 3" chair screws
- Repeat until all seats and backs are assembled.

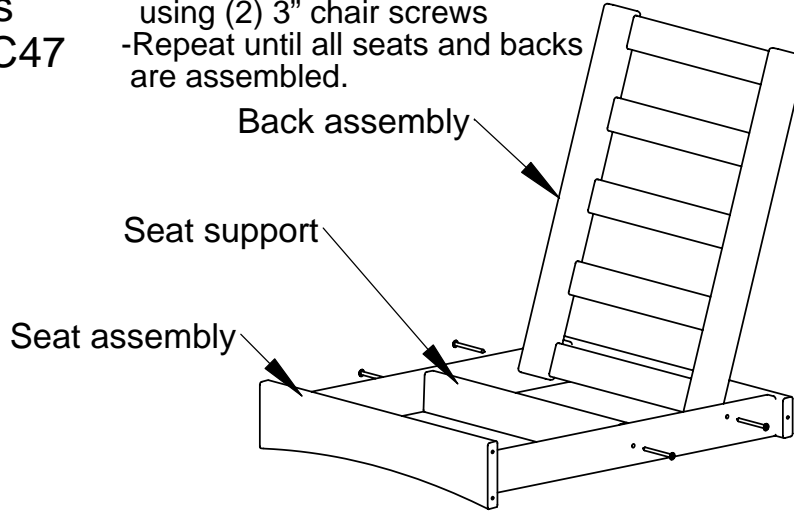

Step 2

- Lay a seat assembly on its side.
- Attach left sideframe to seat assembly and left top rail using (4) 3" chair screws

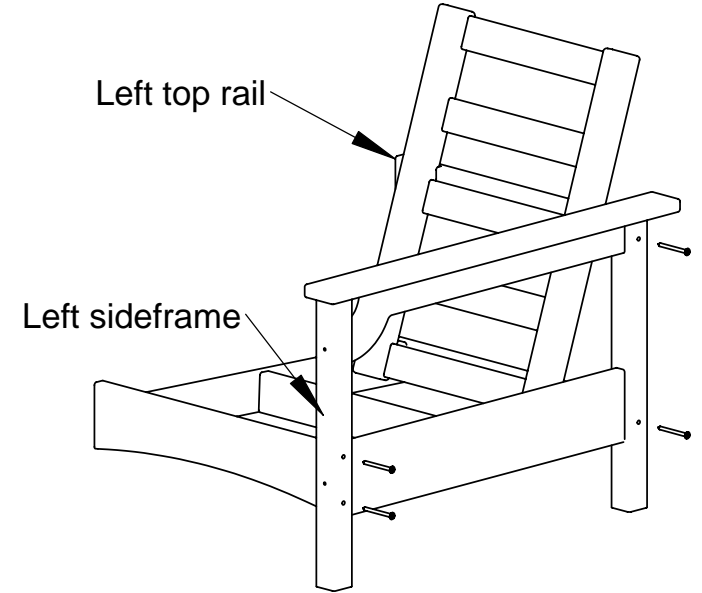

Step 3

- Lay another seat assembly on its side.
- Attach right sideframe to seat assembly and right top rail using (4) 3" chair screws

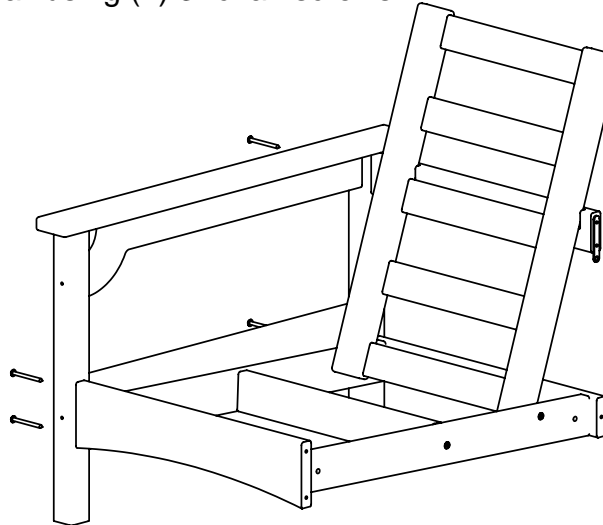

See page 2

TOOLS NEEDED

- 4mm" HEX KEY: INCLUDED
- Phillips head screwdriver

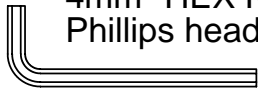

Qty.	Description
------	-------------

16	A - 3" Chair screw
3	B - capnut
1	C - 1 1/2" chair bolt
2	D - 3 1/4" chair bolt

bolts are 1/4-20



Assembly Instructions
Model: CLC71 & CMC71
***CLC71 shown**

- ___ (3) Seat assembly
- ___ (3) Back assembly
- ___ (3) Seat support
- ___ (3) Top rails
Right, Center, Left
- ___ (2) Sideframes
- ___ (2) Front mid leg
- ___ (2) Rear mid leg
- ___ (3) Seat cushion
- ___ (3) Back cushion
- ___ (1) Hardware pack

Step 1

- Attach seat support to seat assembly using (2) 3" chair screws
- Attach back assembly to seat assembly using (2) 3" chair screws
- Repeat until all seats and backs are assembled.

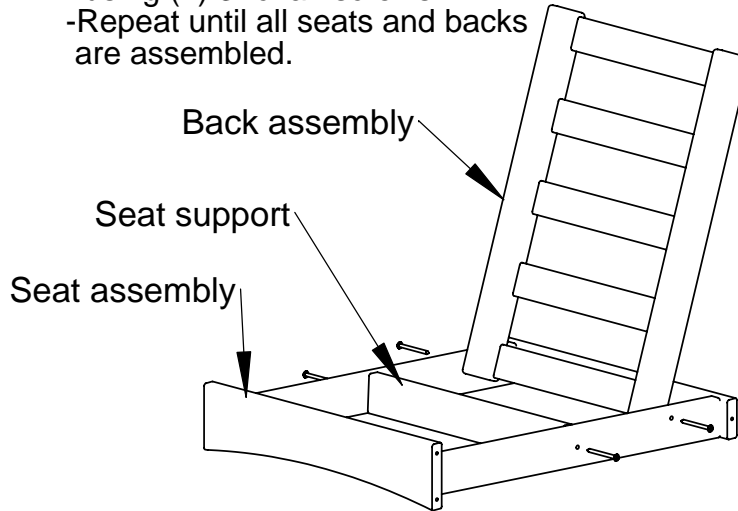

Step 2

- Lay a seat assembly on its side.
- Attach left sideframe to seat assembly and left top rail using (4) 3" chair screws

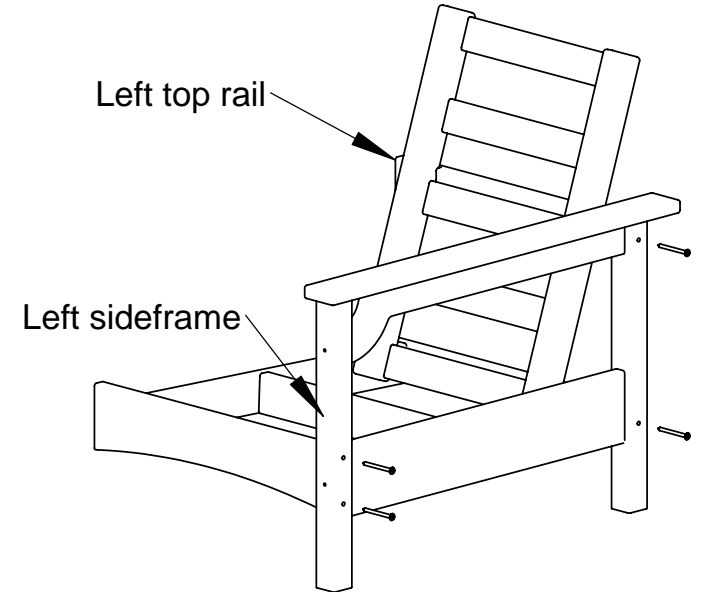

Step 3

- Lay another seat assembly on its side.
- Attach right sideframe to seat assembly and right top rail using (4) 3" chair screws

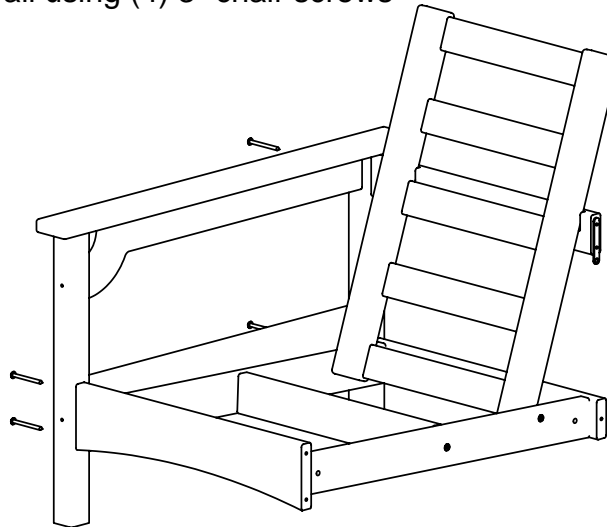

See page 2

TOOLS NEEDED

- 4mm" HEX KEY: INCLUDED
- Phillips head screwdriver



Qty.	Description
20	A - 3" Chair screw
6	B - capnut
2	C - 1 1/2" chair bolt
4	D - 3 1/4" chair bolt

bolts are 1/4-20



All Weather Furnishings

Model: CLT1818

- (2) Sideframes
- (2) Braces
- (1) Table top
- (1) Hardware pack

Step 1
 Lay table top face down.
 Attach sideframes to table top
 using (4) 3" chair screws

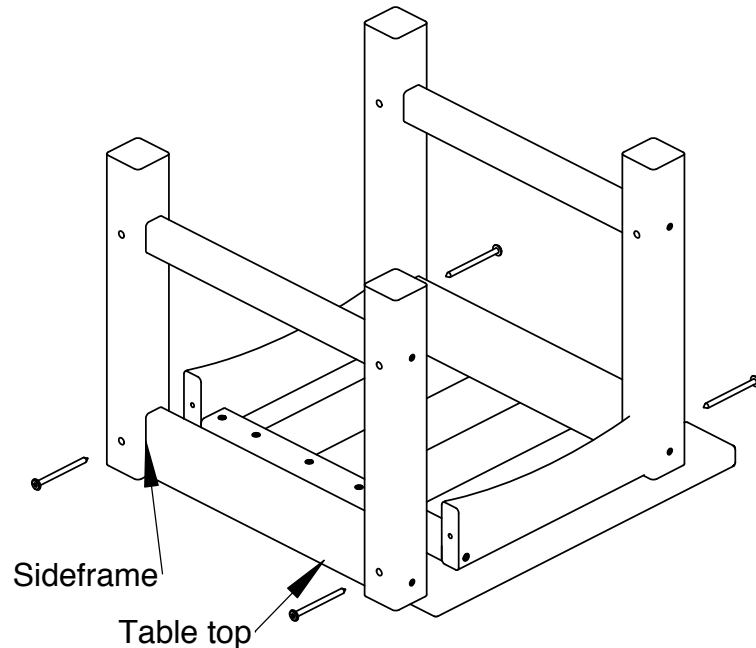

Step 2
 Attach braces to sideframes
 using (4) 3" chair screws

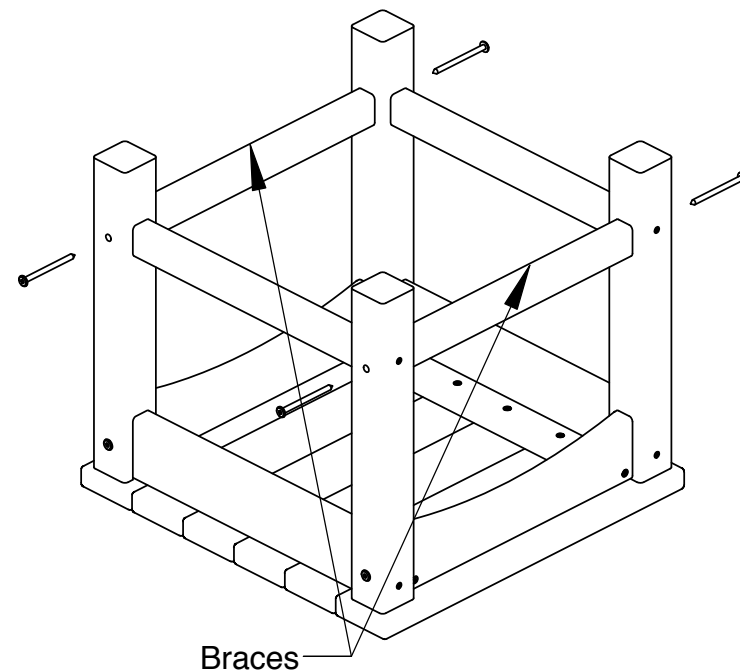

TOOLS NEEDED

PHILLIPS HEAD SCREW DRIVER
 4mm HEX KEY, ALLEN, T-HANDLE
 (INCLUDED)

Qty.	Description
------	-------------

8	A - .27 X 3 SOCKET WAFER A
---	----------------------------

POLYWOOD®

All Weather Furnishings

Join the POLYWOOD® Community

Share in the love of outdoor living, recycling, and more...



POLYWOOD



@POLYWOODINC



youtube.com/polywood



POLY-WORLD
Blog



POLYWOOD



To view our full warranty, please visit the warranty page on our website at polywoodinc.com/resources.

If you have questions or concerns regarding assembly instructions or missing parts, please contact us at (877) 457-3284 or email support@polywoodinc.com



Step 4
Fit all sections together with mid legs

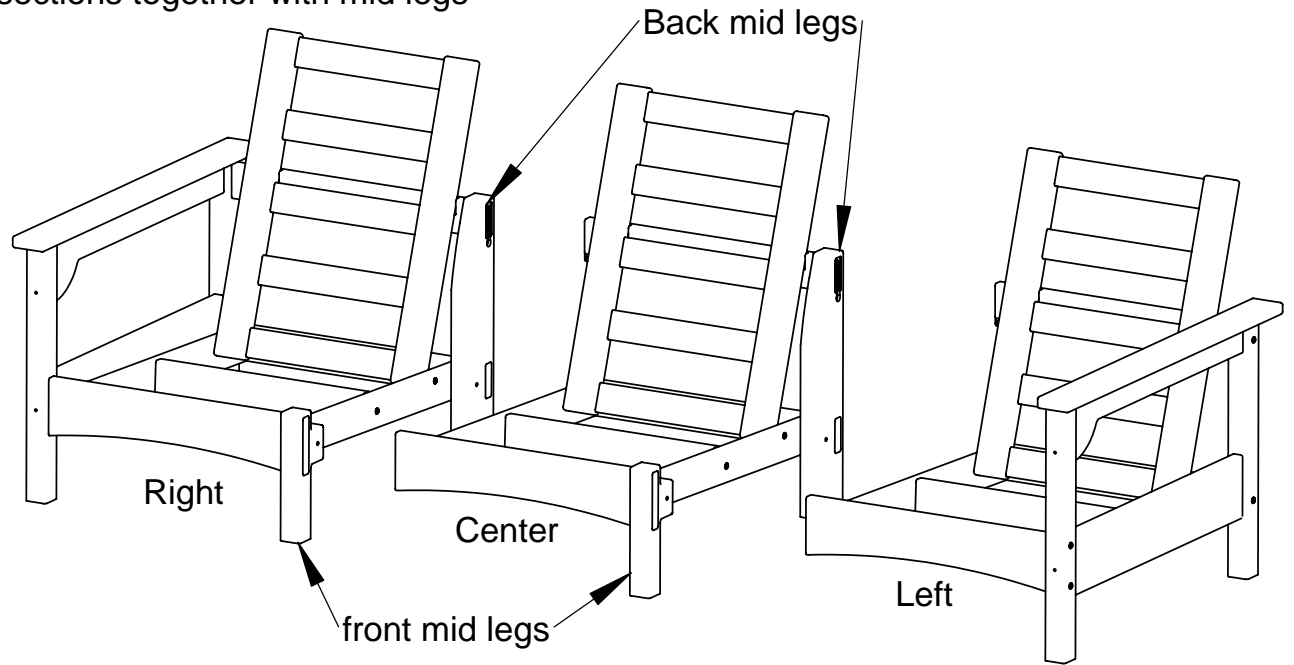

Step 5
Attach all sections together using
B - (6) capnuts
C - (2) 1 1/2" chair bolts
D - (4) 3 1/4" chair bolts

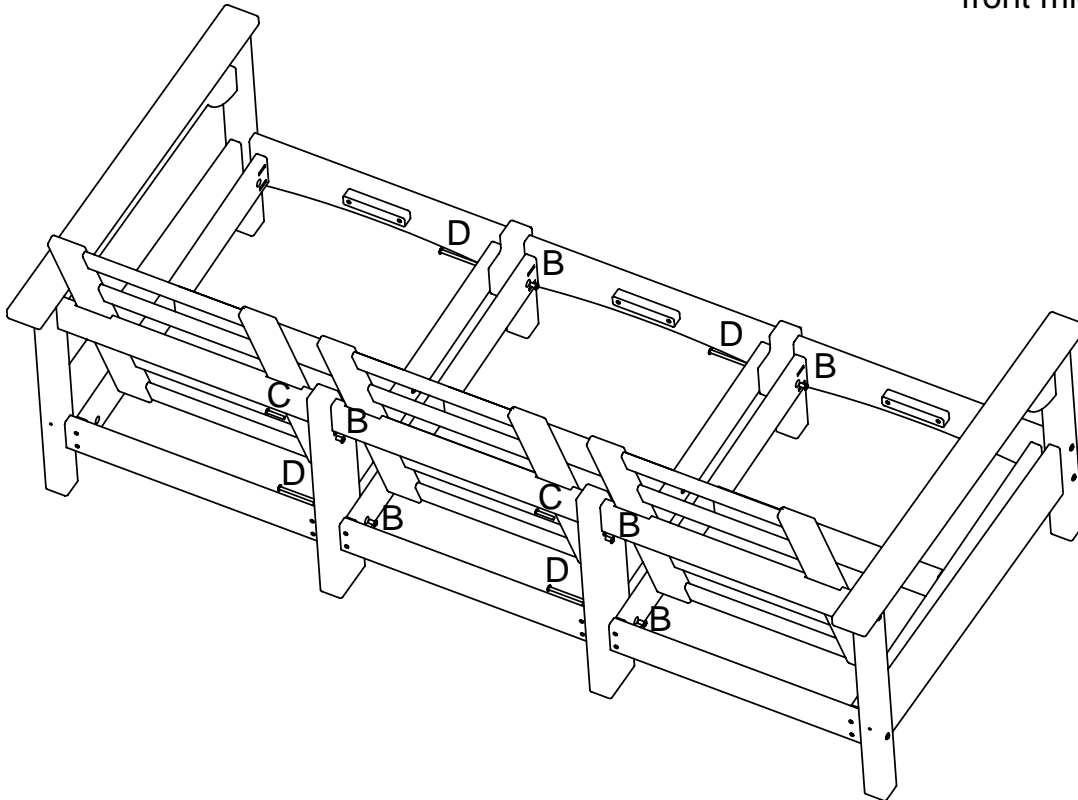

CMC71

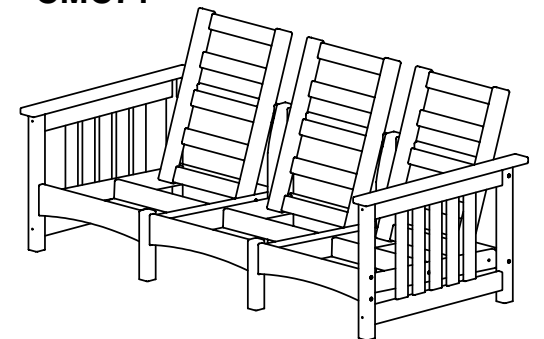



Step 4
Fit all sections together with mid legs

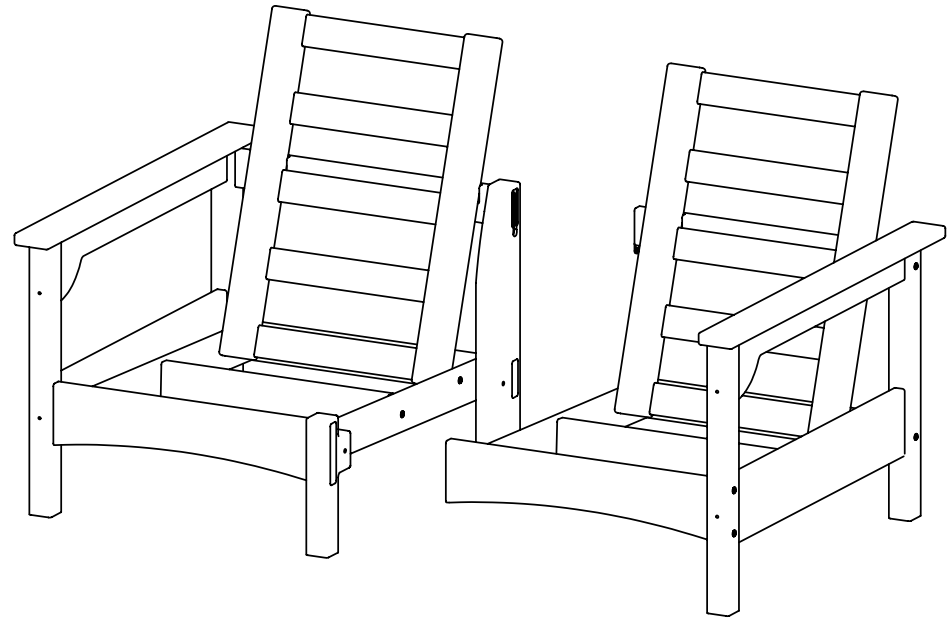

Step 5
Attach all sections together using
B - (3) capnuts
C - (1) 1 1/2" chair bolt
D - (2) 3 1/4" chair bolts

