



# Greenfield Potting Bench

Model# 11203

Assembly Instructions

<u>Part #</u>	<u>Description</u>	<u>Qty</u>
1	2" sq. x 48 $\frac{1}{4}$ " Back Left Post	1
2	2" sq. x 48 $\frac{1}{4}$ " Back Right Post	1
3	2" sq. x 38" Front Post	2
4	1 $\frac{1}{2}$ x 4 x 46 $\frac{1}{2}$ " Table Support	2
5	1 $\frac{1}{2}$ x 4 x 46 $\frac{1}{2}$ " Shelf Support	2
6	1 $\frac{1}{2}$ x 4 x 20 $\frac{1}{4}$ " Side Rail	4
7	$\frac{7}{8}$ x 3 x 20 $\frac{1}{4}$ " PtB Rail	14
8	$\frac{7}{8}$ x 3 x 46 $\frac{1}{2}$ " Back Rail	1
9	1 $\frac{1}{2}$ x 5 $\frac{1}{2}$ x 46 $\frac{1}{2}$ " Back Rail	1
10	1 $\frac{1}{2}$ x 5 $\frac{1}{2}$ x 42 $\frac{1}{2}$ " Shelf Rail	1
11	10 $\frac{3}{4}$ " Shelf Support Bracket	2
12	1 $\frac{1}{2}$ x 5 $\frac{1}{2}$ x 43" Table Top Rail	3
13	$\frac{7}{8}$ x 1 $\frac{1}{2}$ x 16 $\frac{1}{2}$ " Table Brace	2
14	16 $\frac{1}{2}$ " Table Top End Cap	2
15	5 $\frac{1}{2}$ " Shelf End Cap	2
16	Hardware Bag (includes:)	1
	2" sq." Post Cap	4
	1 $\frac{1}{4}$ " Painted Screw	12
	$\frac{3}{4}$ " Painted Screw	48
	Super Glue Tube	1

## General Information

PLEASE READ THROUGH BEFORE BEGINNING ASSEMBLY.

IMPORTANT: Check boxes for Contents Listed

Check inside of parts as some parts are packaged  
inside of others

In the event of missing, damaged or defective parts  
please call our customer service dept. at 1-877-258-6020

When assembling components, place on a clean, flat  
non-abrasive surface to avoid scratches

## Tools Required

- ... Battery or Electric Drill with #2 phillips bit
- ... File
- ... Hammer or Rubber Mallet (recommended)

# Warranty Statement

## 20 Year Guarantee

**Please call manufacturer direct with questions concerning missing or defective parts at Toll Free: 877-258-6020.**

Dura-trel, Inc. products are warranted to be free from manufacturing defects resulting in delaminating, peeling, flaking, corroding, cracking, crazing, or extreme amounts of fading or bleaching causing the PVC to change to its natural color for a period of 20 years from the date of purchase.

*Normal weathering is defined as exposure to sunlight and extremes of weather and atmosphere which will cause any colored surface to gradually fade.*

### **CONDITIONS NOT COVERED BY THIS WARRANTY:**

- A. Physical abuse, misuse, neglect, or improper storage.
- B. Improper installation or installation not in strict adherence to the instructions written by Dura-Trel, Inc.
- C. This warranty does not apply if materials are painted, varnished, or coated with any substance.
- D. Dura-Trel, Inc. is not responsible for damages to product during shipping.
- E. Damage attributable to atmospheric pollutants, hail, lightning, hurricane, tornado, wind borne objects, earthquake, fire, mildew, casualty, act of God, building or ground settlement, or subjection to stress or weight.

### **CLAIMS AND REMEDIES:**

If a Dura-Trel, Inc. product is determined to have a manufacturing defect which is covered by this warranty, Dura-Trel, Inc. will replace the material containing the defect (labor not included) F.O.B from the point of manufacture. Dura-trel, Inc. will not be responsible for any cost incurred in the removal or reinstallation of the product.

**Important:** An claims must be sent to the following address and should describe the defect claim.

**Dura-Trel, Inc., P.O. Box 122, Sheboygan Falls, WI 53085**

Dura-Trel, Inc. reserves the right to discontinue or change its design, and or color. If the original color or style is not available, Dura-Trel, Inc. shall have the right to substitute a product designated by Dura-Trel, Inc.

Dura-Trel, Inc. shall not be liable for any incidental, special, or consequential damages arising out of the use of these products

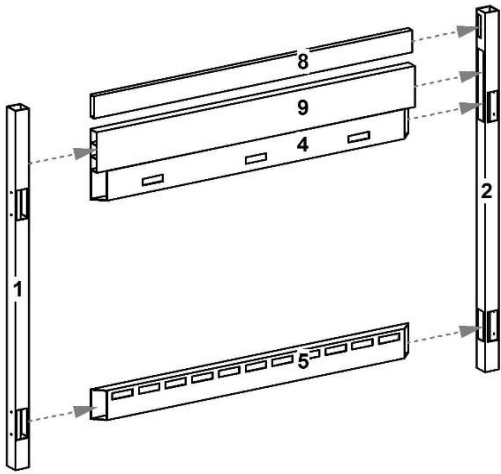

**1**

Insert  $\frac{7}{8}$ " x 3" x 46 $\frac{1}{2}$ " back rail (part 8) into top hole in back right post (part 2). Insert 1 $\frac{1}{2}$ " x 5 $\frac{1}{2}$ " x 46 $\frac{1}{2}$ " back rail (part 9) into top of large hole of back right post. Insert one table support (part 4), into bottom of large hole of back right post. Insert one shelf support (part 5) into bottom hole of right back post. Insert free ends of all rails into corresponding holes of back left post (part 1).

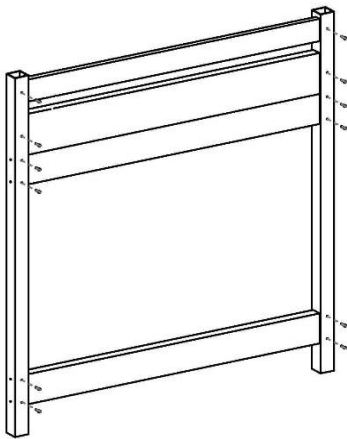

**2**

Flip over potting bench back panel, keeping parts inserted into posts. Using six  $\frac{3}{4}$ " screws per post, screw together potting bench back panel. Be sure that all parts are fully inserted into posts before

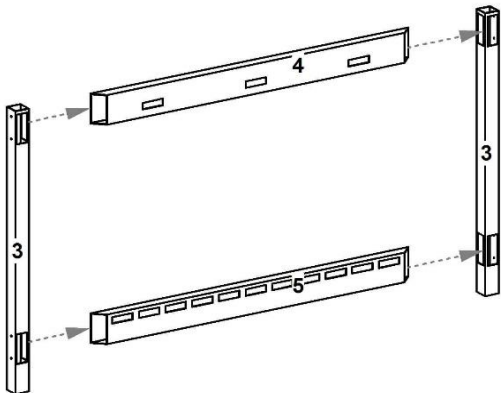

**3**

Insert one table support (part 4), into top hole of one front post (part 1). Insert one shelf support (part 5) into bottom hole of same front post. Insert free ends of table and shelf support into corresponding holes of second front post (part 1).

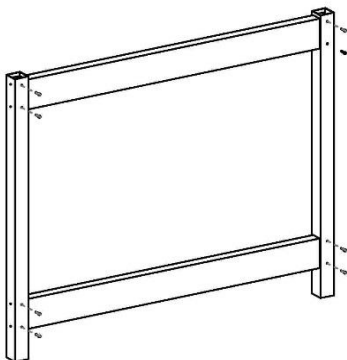

**4**

Flip over potting bench front panel, keeping parts inserted into posts. Using four  $\frac{3}{4}$ " screws per post, screw together potting bench front panel. Be sure that all parts are fully inserted into posts before

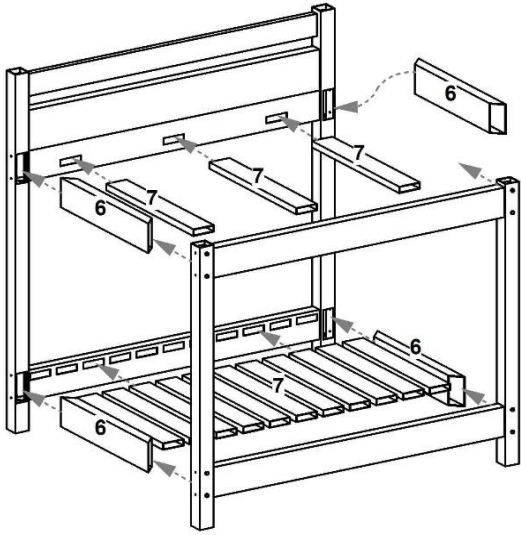

**5**

Insert three  $\frac{7}{8}$ " x 3" x 20 $\frac{1}{4}$ " table/shelf rails (part 7) into table support of back panel. Insert eleven  $\frac{7}{8}$ " x 3" x 20 $\frac{1}{4}$ " table/shelf rails (part 7) into shelf support of back panel. Insert two 1 $\frac{1}{2}$ " x 4" x 20 $\frac{1}{4}$ " side rails (part 6) into back right and back left post. Insert free ends of all rails into corresponding holes of front panel.

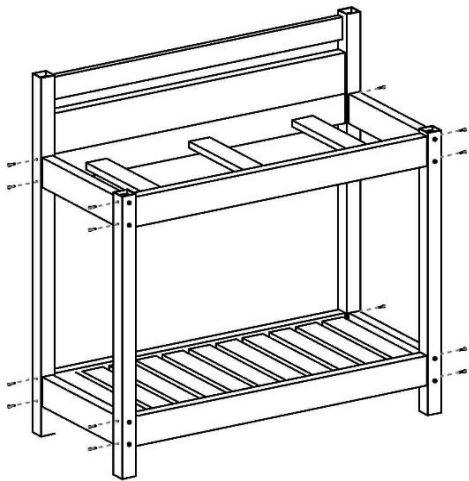

**6**

Using four  $\frac{3}{4}$ " screws per post, screw together potting bench. Be sure that all parts are fully inserted into posts before securing.

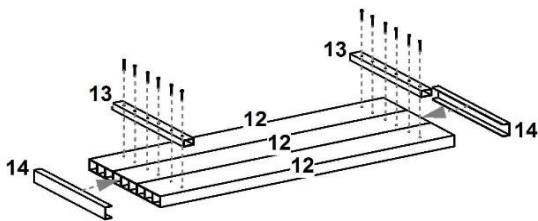

**7**

Lay out three  $\frac{1}{2}$ " x 5 $\frac{1}{2}$ " x 43" table top rails (part 12). Using six  $1\frac{1}{4}$ " screws per piece, insert screws through two  $\frac{7}{8}$ " x 1 $\frac{1}{2}$ " x 16 $\frac{1}{2}$ " table brace (part 13). Fasten screws to screw pilot holes of the three table top rails. Using super glue tube, apply glue to inner edges of 16 $\frac{1}{2}$ " table top end cap (part 14). Slide end cap onto ends of table top. Using a file or sandpaper, file sharp corners of end cap.

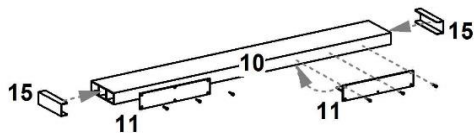

**8**

Lay out the 1½" x 5½" x 42½" shelf rail and two 10¾" shelf support brackets. Using a tape measure, mark shelf rail 6" in from each end. Using three ¾" screws per bracket, fasten narrow end of each bracket to shelf rail 6" from end of shelf rail. Shelf rail should sit on part of bracket without screw holes. Apply glue to inner edges of 5½" shelf end cap (part 15). Slide end cap onto ends of shelf rail.

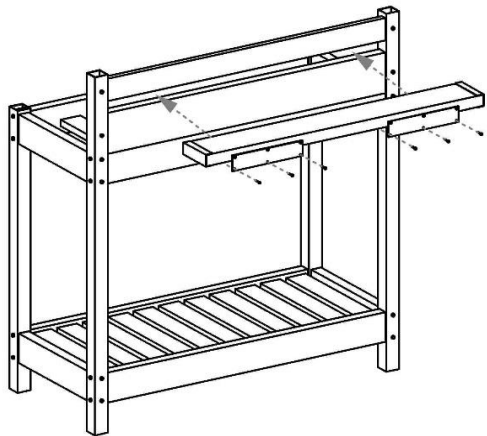

**9**

From behind, slide shelf through gap in back panel of potting bench. Using six ¾" screws, fasten wide end of brackets to 1½" x 5½" x 46½" back rail. Snap kappet screw caps over screw heads.

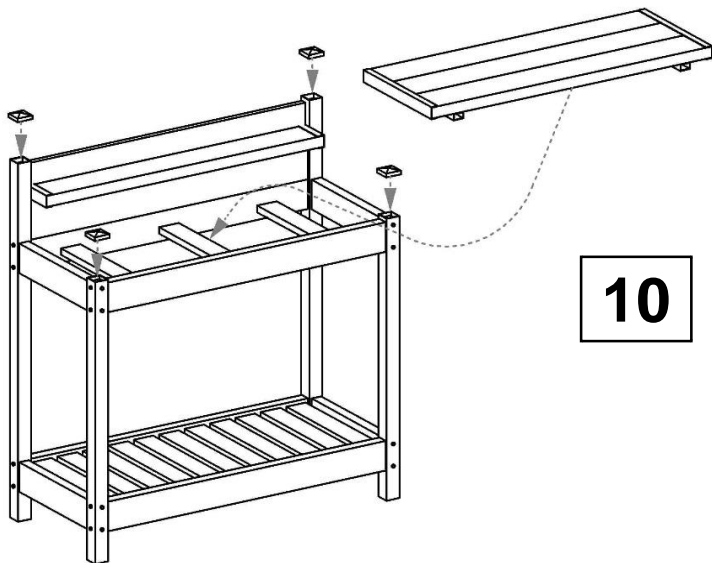

**10**

Apply PVC glue to inner edges of four 2" sq. post caps and place on top of each post. Set table top assembly into working area of potting bench. The table top is designed to be removed for easy and quick cleaning.

11203	Greenfield Potting Bench	
1	2" sq. x 48 $\frac{3}{4}$ " PtB Back Left P	1.00
2	2" sq. x 48 $\frac{3}{4}$ " PtB Back Right	1.00
3	2" sq. x 38" PtB Front Post	2.00
4	1 $\frac{1}{2}$ x 4 x 46 $\frac{1}{2}$ " PtB Table Rail	2.00
5	1 $\frac{1}{2}$ x 4 x 46 $\frac{1}{2}$ " PtB Shelf Rail	2.00
6	1 $\frac{1}{2}$ x 4 x 20 $\frac{1}{4}$ " PtB Rail	4.00
7	1 $\frac{1}{2}$ x 5 $\frac{1}{2}$ x 42 $\frac{1}{2}$ " PtB Shelf Ra	1.00
8	1 $\frac{1}{2}$ x 5 $\frac{1}{2}$ x 46 $\frac{1}{2}$ " PtB Back Rai	1.00
9	$\frac{7}{8}$ x 3 x 46 $\frac{1}{2}$ " PtB Back Rail	1.00
10	10 $\frac{3}{4}$ " PtB Half Bracket	2.00
11	1 $\frac{1}{2}$ x 5 $\frac{1}{2}$ x 43" PtB Table Top	3.00
12	$\frac{7}{8}$ x 1 $\frac{1}{2}$ x 16 $\frac{1}{2}$ " PtB TableBra	2.00
13	$\frac{7}{8}$ x 3 x 20 $\frac{1}{4}$ " PtB Rail	14.00
14	16 $\frac{1}{2}$ " PtB End Cap	2.00
15	5 $\frac{1}{2}$ " End Cap	2.00
16	Hardware Bag	1.00
	2" sq." Post Cap	4.00
	1 $\frac{1}{4}$ " Painted Screw	12.00
	$\frac{3}{4}$ " Painted Screw	48.00
	Super Glue Tube	1.00