

HAMPTON BAY®

Item #
Model # Lounge
65-518333B;
Bench, FG19233S

USE AND CARE GUIDE

BRIAR RIDGE 3PC SECTIONAL SET BARE

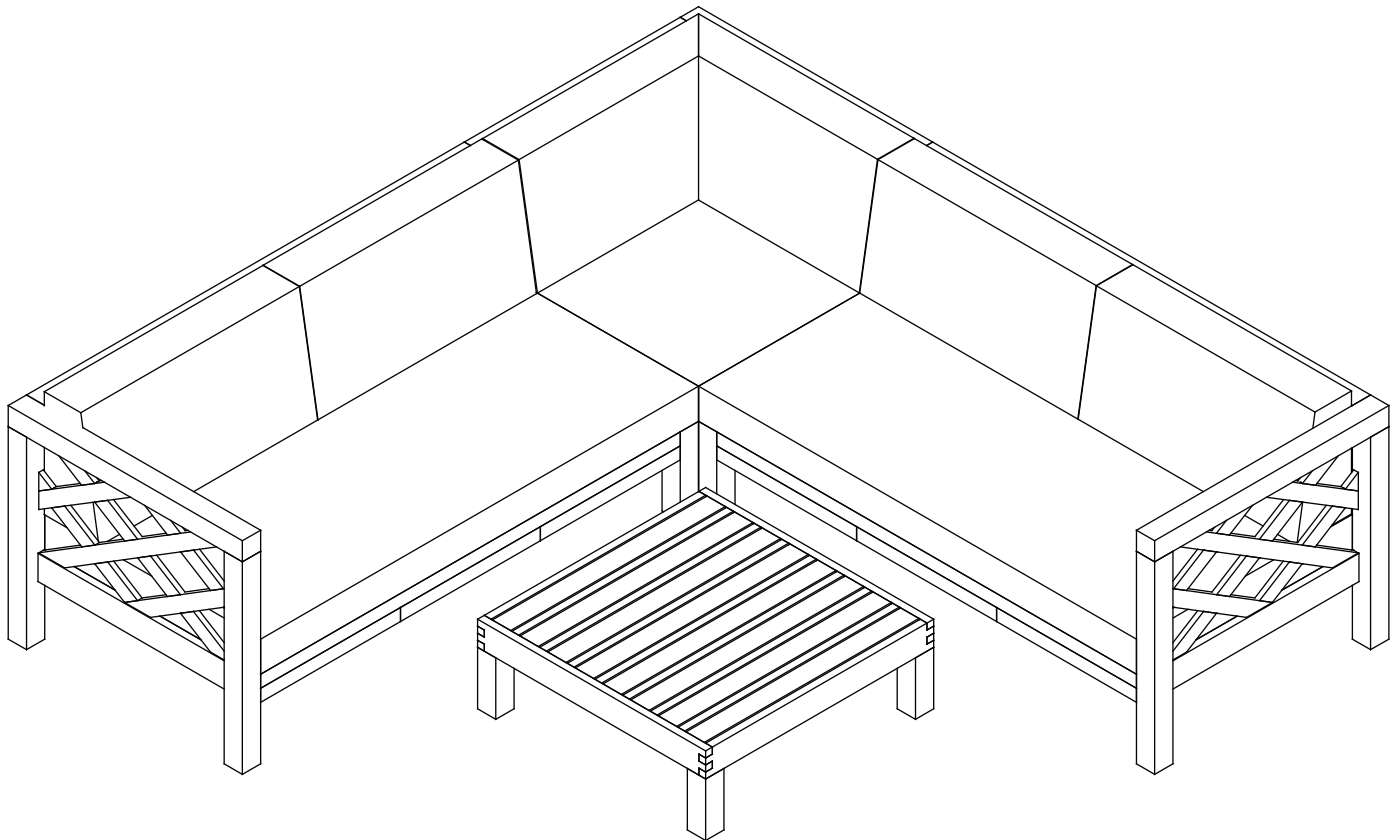

Questions, problems, missing parts? Before returning to the store,
call Hampton Bay Customer Service
8 a.m. - 7 p.m., EST, Monday – Friday, 9 a.m. – 6 p.m., EST, Saturday

1-855-HD-HAMPTON

HAMPTONBAY.COM

THANK YOU

We appreciate the trust and confidence you have placed in Hampton Bay through the purchase of this Side table. We strive to continually create quality products designed to enhance your home. Visit us online to see our full line of products available for your home improvement needs. Thank you for choosing Hampton Bay!

Warranty

TWO YEAR FRAME, WEAVE AND FABRIC LIMITED WARRANTY

WHAT IS COVERED

We warrant the frame, weave and fabric to be free of manufacturing defects to the original purchaser for two years. For glass table top we warrant 30 days from the date of purchase.

WHAT IS NOT COVERED

This warranty does not cover commercial use, hardware, acts of nature, fire, freezing and abusive use. In addition, purchased parts are not covered under this warranty.

We reserve the right to make substitutions with similar merchandise, if the model in question is no longer in production. Contact the Customer Service Team at 1-855-HD-HAMPTON or visit www.Hamptonbay.com.

Pre-Installation

PLANNING INSTALLATION

To prevent damage, place all parts on a soft surface during assembly. Remove all protective caps before beginning assembly.

HARDWARE INCLUDED

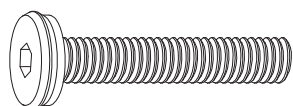

AA



BB



CC

Part	Description	Quantity
(1)	Bolt M6x35mm	7
(2)	Screws M6x45mm	5
(3)	Hex wrench 4mm	1

PACKAGE CONTENTS(CHaise)

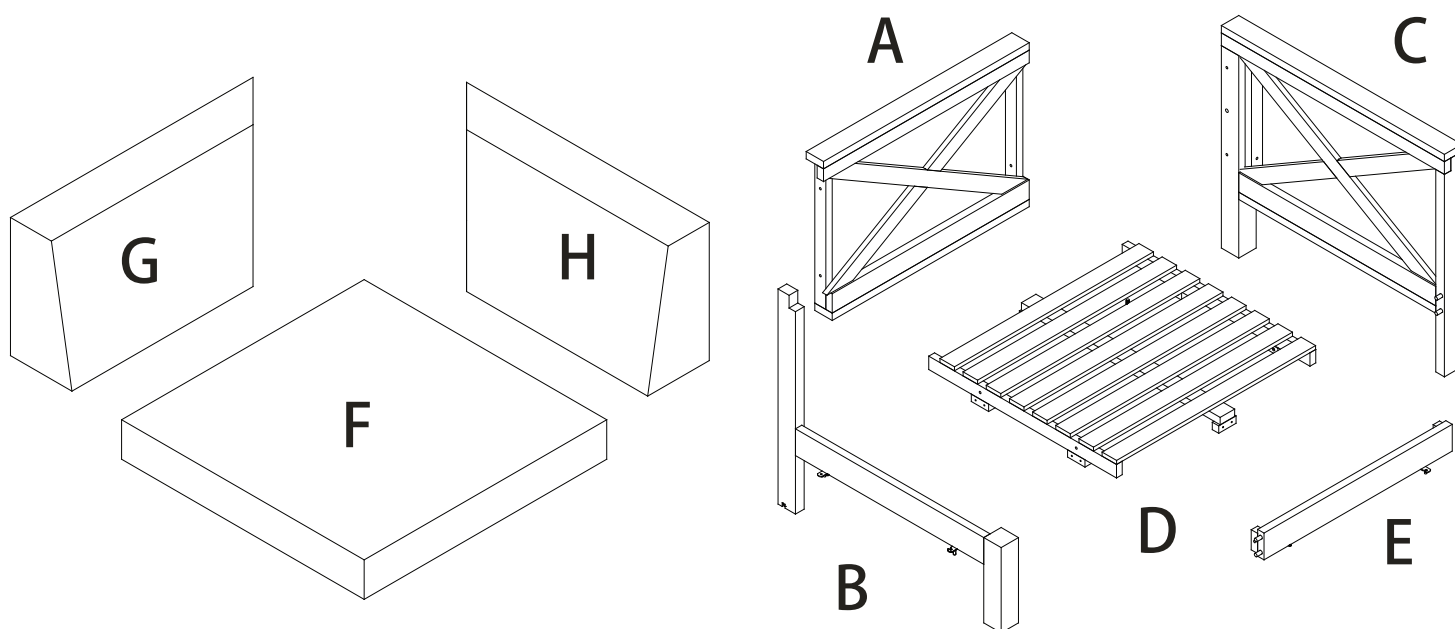

Part	Description	Quantity
A	Backrest Panel	1
B	Left Arm Panel (With Pre- Installed Levellers)	1
C	Right Arm Panel (With Pre- Installed Levellers)	1
D	Seat Panel	1
E	Supoport Bar	1
F	Seat Cushion	1
G	Left Back Cushion	1
H	Right Back Cushion	1

1 Attaching the chaise seat to the back

Place the Right Arm Panel (C) with inside face skywards onto a clean, soft surface to avoid any scratches or damages to the product.

- **Step 2.1:** Align the dowels of Support Bar (E) into the positions in the Right Arm Panel (C). Then, affix Support Bar (E) with Right Arm Panel (C) by using Bolt (1) and Allen Key (3).
- **Step 2.2:** Attach the Backrest Panel (A) onto Right Arm Panel (C) by using Bolts (1) and Allen Key (3) as shown above.

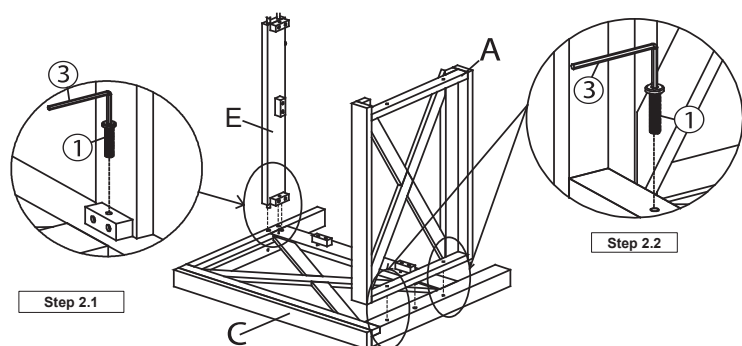

2 Attaching the chaise armrest to the seat

- With the help of your adult partner, place Left Arm Panel (B) onto the assembled in Step 2 as shown above.
- **Step 3.1:** Align the dowels of Support Bar (E) into the positions in the Left Arm Panel (B). Then, affix Support Bar (E) with Left Arm Panel (B) by using Bolt (1) and Allen Key (3) as shown above.
- **Step 3.2:** Pre-attach the Left Arm Panel (B) onto Backrest Panel (A) by using Bolts (1) and Allen Key (3) as shown above.

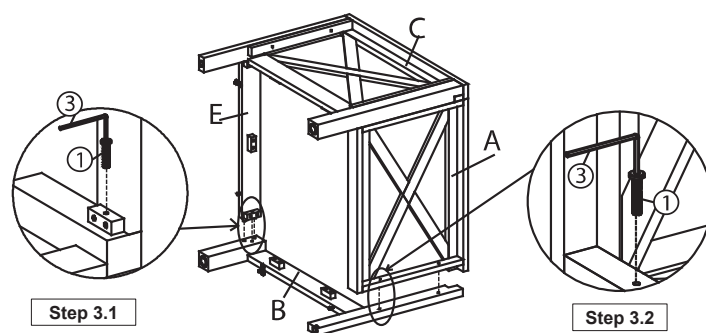

3 Attaching the armrest to the seat

- With the help of your adult partner, place the assembled in Step 3 right side up as shown above.
- By hand, hold Left Arm Panel (B) and Backrest Panel (A) together tightly then secure the Left Arm Panel (B) and Backrest Panel (A) by using Bolts (1) and Allen Key (3) as shown above.

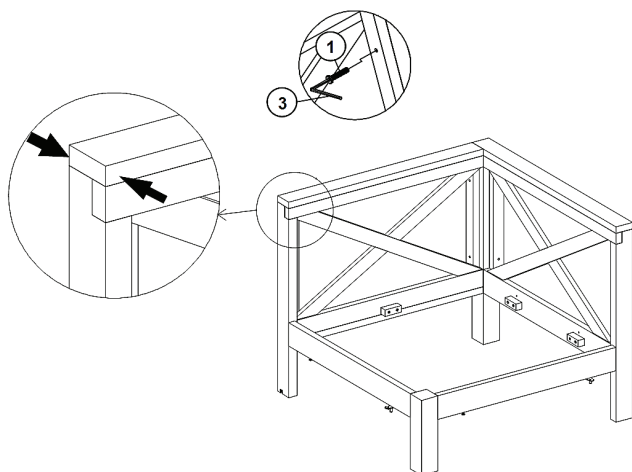

4 Completing the assembly

- Attach the Seat Panel (D) into the Corner Chair as shown in picture above.
- Affix Seat Panel (D) with Corner Chair by using Screws (2) and Allen Key (3).
- Note: Using Screws (2) from inside to outside of Seat Panel (D).

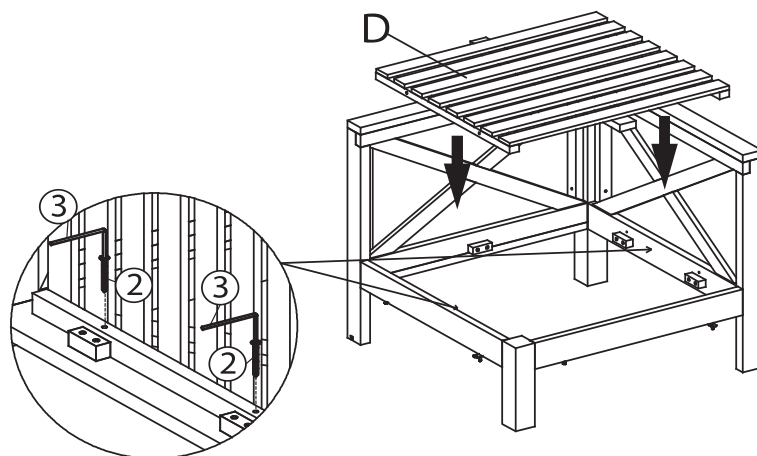

5 Attaching the sofa armrest to the back

- Inspect the Corner Chair and make sure all parts are adequately connected.
- In a sequential manner, tighten all Screws and Bolts at all joints.

With assistance from your adult partners, adjust the Levellers to desired height to avoid wobbles.

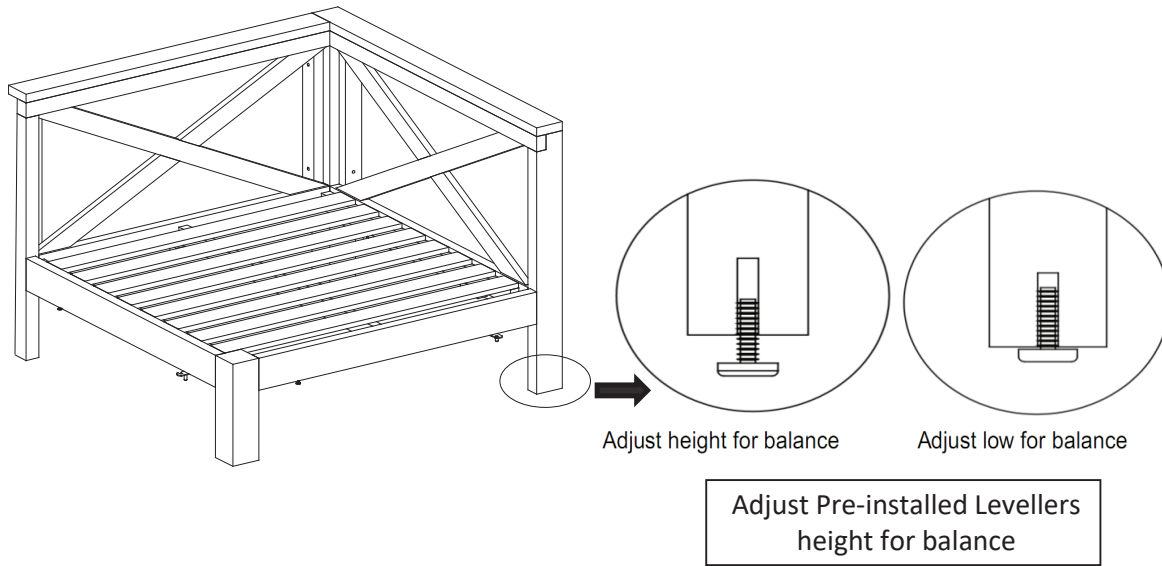

6 Attaching the back to the seat

- Turn the Corner Chair right side up.
- Place Seat Cushion (F), Left Back Cushion (G) and Right Back Cushion (H) to Seat Panel (D).
- Inspect it and make sure all parts are adequately connected.
- Ensure all screws, bolts are fully locked into position and secured.
- The Corner Chair is ready to be used.

Caution: This Armchair can only be used on a flat, level surface.

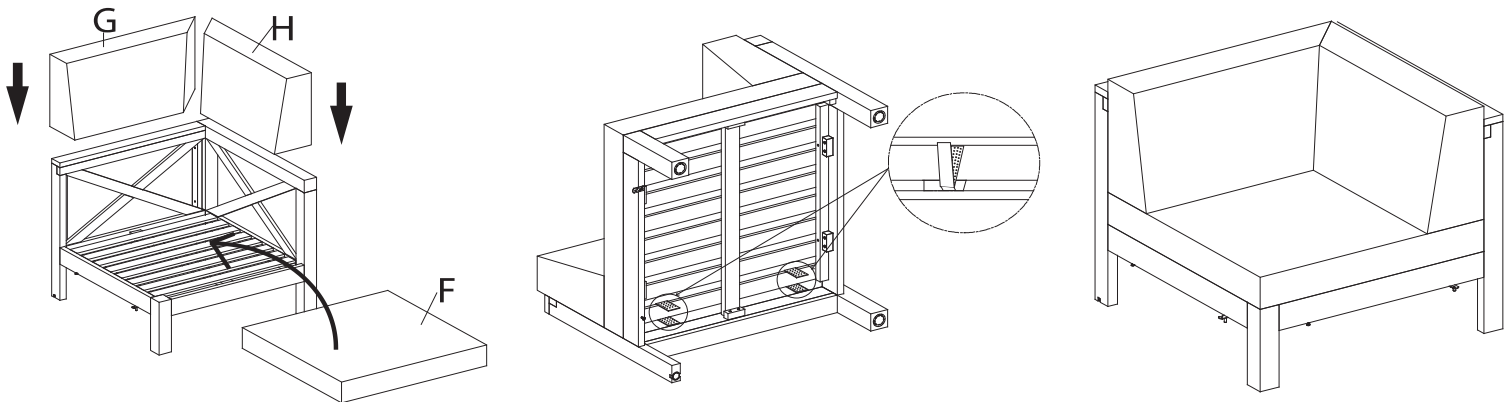

PACKAGE CONTENTS

HARDWARE INCLUDED

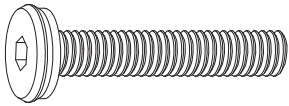

(1)

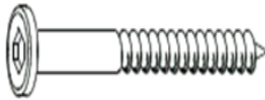

(2)



(3)

Part	Description	Quantity
(1)	Bolt M6x35mm	7
(2)	Screws M6x45mm	5
(3)	Hex wrench 4mm	1

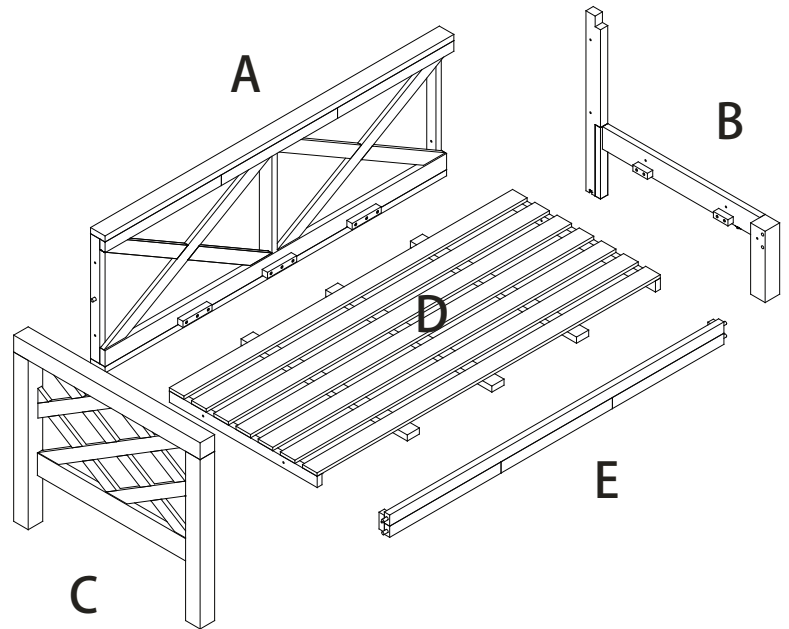
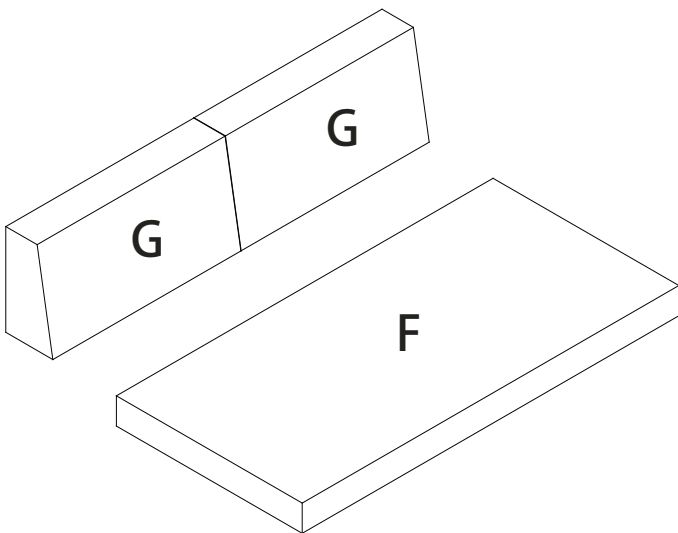

Part	Description	Quantity
A	Backrest Panel	1
B	Right Arm Panel (With Pre- installed Levellers)	1
C	Left Arm Panel (With Pre- installed Levellers)	1
D	Seat Panel	1
E	Support Bar	1
F	Seat cushion	1
G	Right Back Cushion	1

1 Attaching the chaise seat to the back

- Place the Left Arm Panel (C) with inside face skywards onto a clean, soft surface to avoid any scratches or damages to the product.
- Step 2.1: Align the dowels of Support Bar (E) into the positions in the Left Arm Panel (C).
- Then, affix Support Bar (E) with Left Arm panel (C) by using Bolt (1) and Allen Key(3).
- Step 2.2: Attach the Backrest Panel (A) onto Left Arm Panel (C) by using Bolts (1) and Allen Key(3).

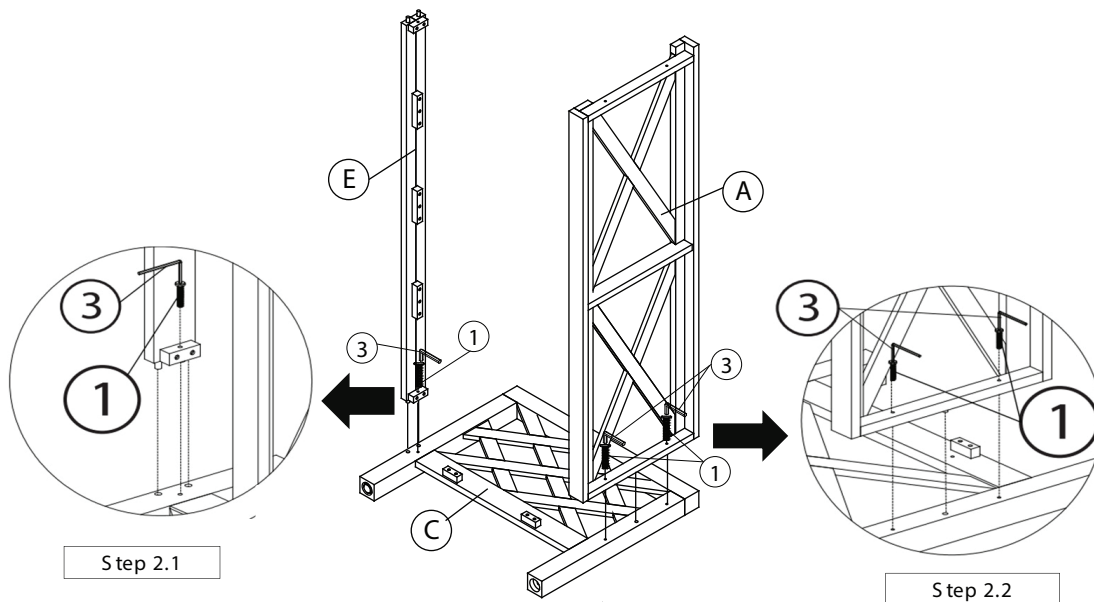

2 Attaching the armrest to the seat

- Place Right Arm Panel (B) onto the assembled frame from Step 2.
- Step 3.1: Align the dowels of Support Bar (E) into the positions in the Right Arm Panel (B).
- Then, affix Support Bar (E) with Right Arm panel (C) by using Bolt (1) and Allen Key(3).
- Step 3.2: Attach the Right Arm Panel (B) onto Backrest Panel (A) by using Bolts (1) and Allen Key (3).

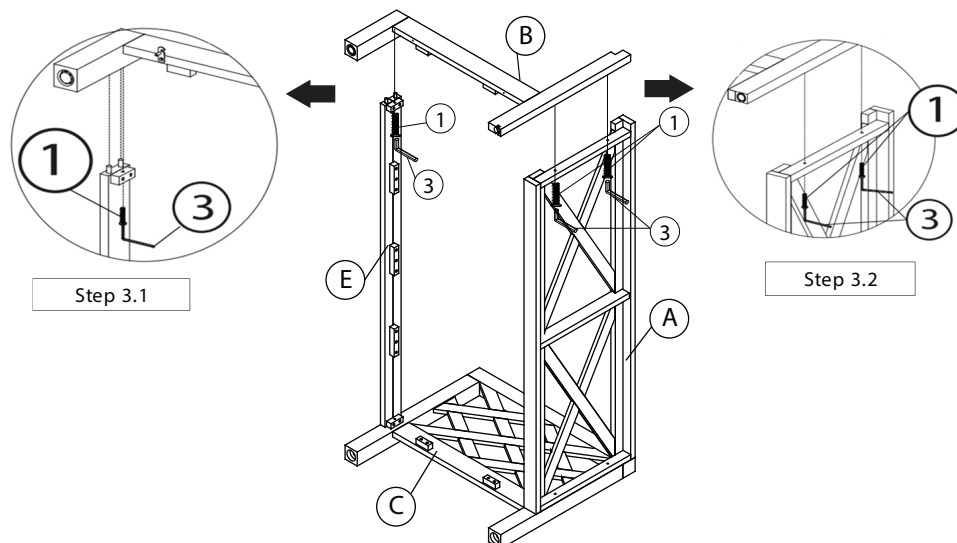

3 Attaching the chaise seat to the back

- Attach the Seat Panel (D) into the Left Chair as shown in picture above.
- Affix Seat Panel (D) with Left Chair by using Screws (2) and Allen Key (3).
- Note: Using Screws (2) from inside to outside of Seat Panel (D).

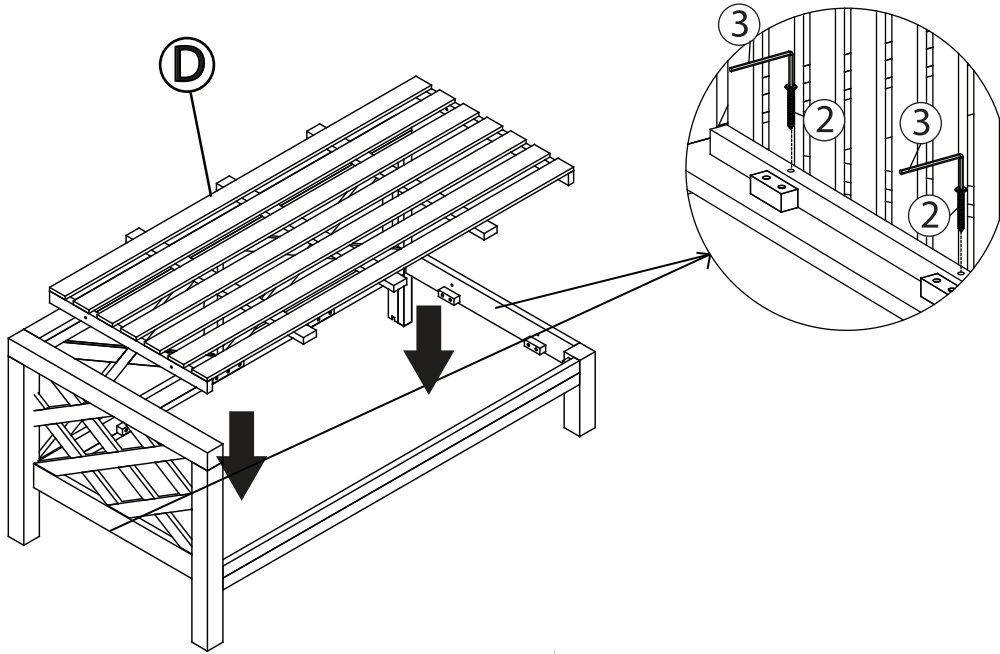

4 Attaching the armrest to the seat

- Inspect the Left Chair and make sure all parts are adequately connected..
- In a sequential manner, tighten all Screws and Bolts at all joints.

With assistance from your adult partners, adjust the Levellers to desired height to avoid wobbles.

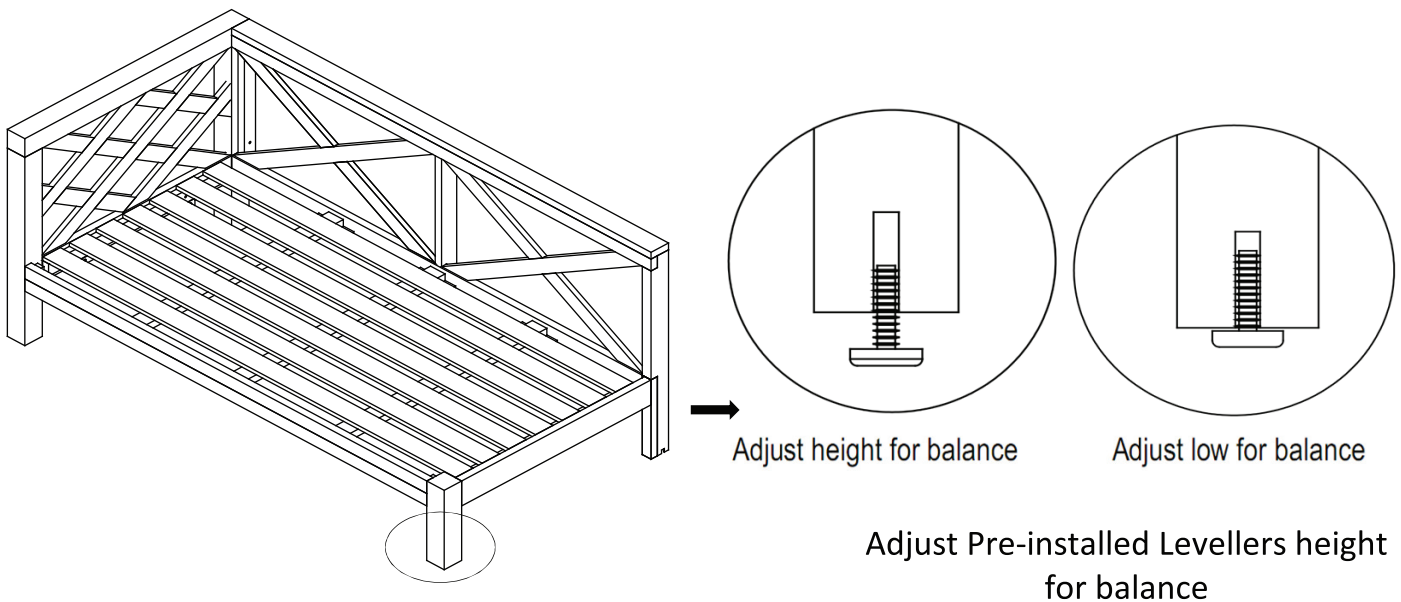

5 Attaching the chaise seat to the back

- Place Seat Cushion (F), Left Back Cushion (G) and Right Back Cushion (H) to Seat Panel (D).

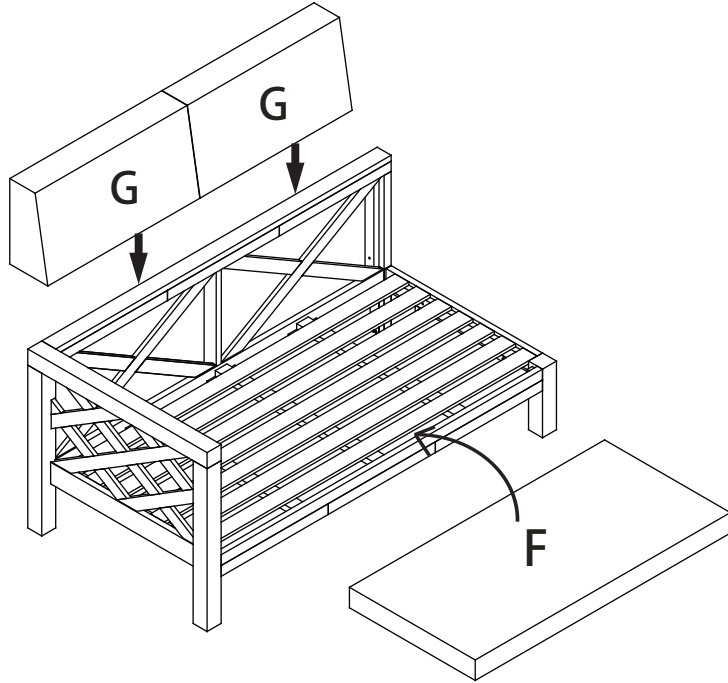

6 Attaching the armrest to the seat

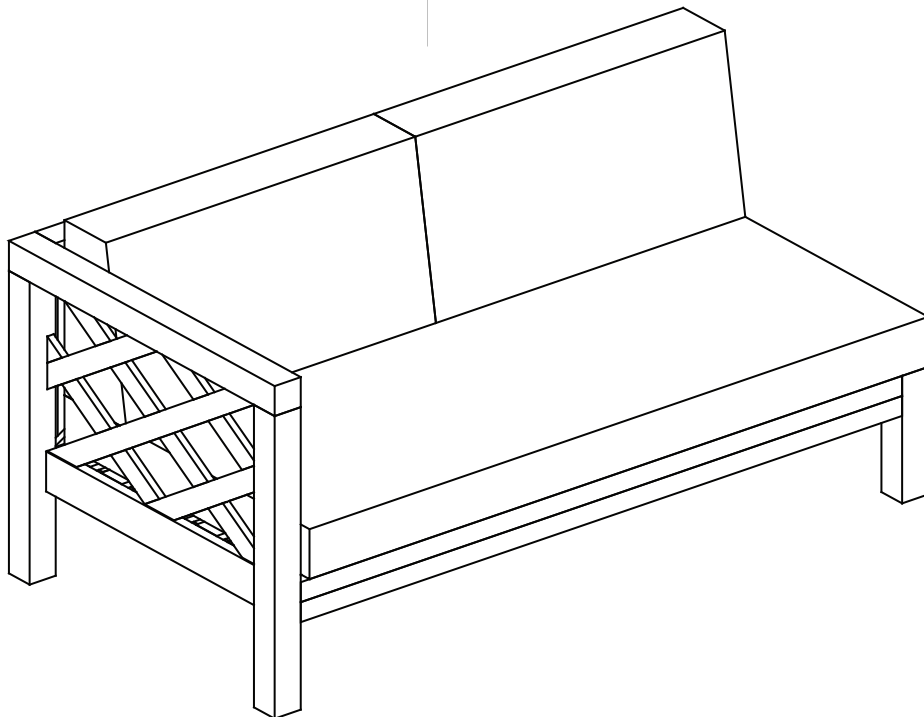

PACKAGE CONTENTS

HARDWARE INCLUDED

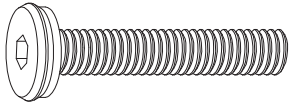

(1)

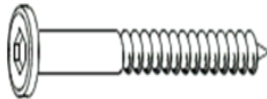

(2)



(3)

Part	Description	Quantity
(1)	Bolt M6x35mm	7
(2)	Screws M6x45mm	5
(3)	Hex wrench 4mm	1

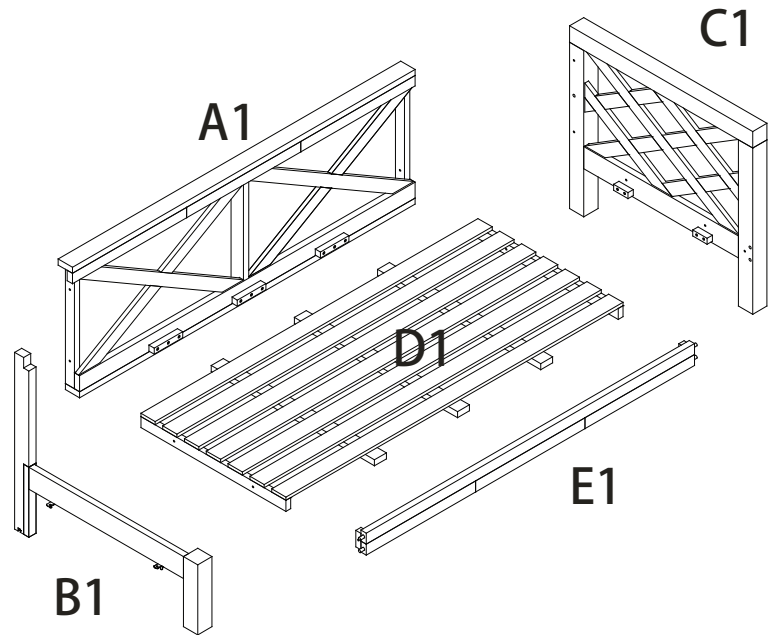
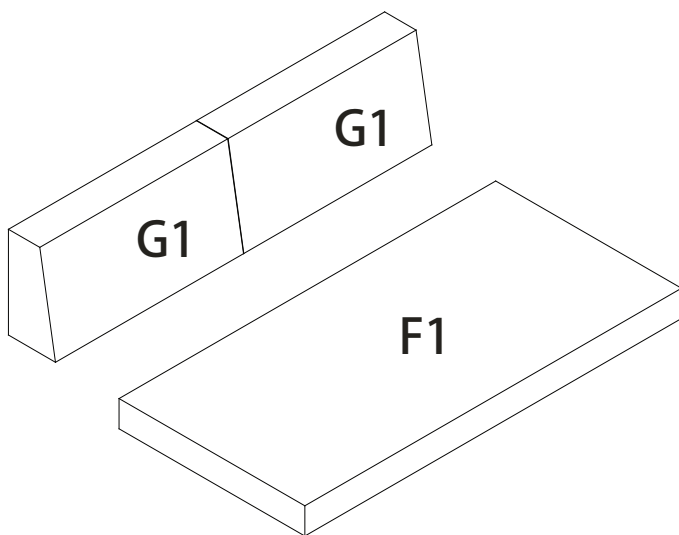

Part	Description	Quantity
A1	Backrest Panel	1
B1	Right Arm Panel (With Pre- installed Levellers)	1
C1	Left Arm Panel (With Pre- installed Levellers)	1
D1	Seat Panel	1
E1	Support Bar	1
F1	Seat cushion	1
G1	Right Back Cushion	1

1 Attaching the chaise seat to the back

- Place Right Arm Panel (B1) onto the assembled frame from Step 2.
- Step 3.1: Align the dowels of Support Bar (E1) into the positions in the Right Arm Panel (B1).
- Then, affix Support Bar (E1) with Right Arm panel (C1) by using Bolt (1) and Allen Key (3).
- Step 3.2: Attach the Right Arm Panel (B1) onto Backrest Panel (A1) by using Bolts (1) and Allen Key (3).

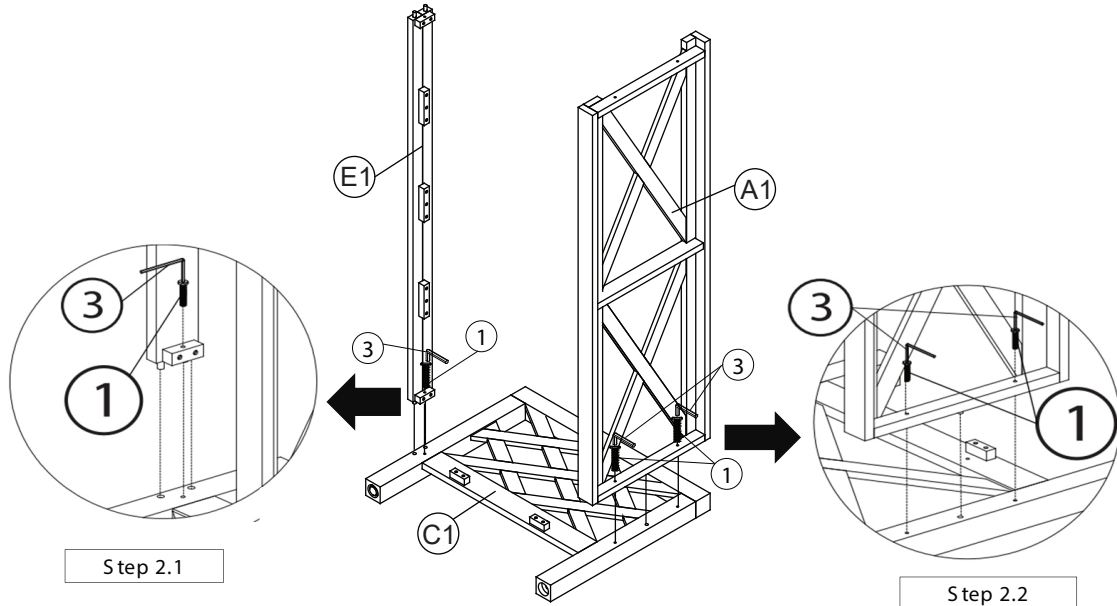

2 Attaching the armrest to the seat

- Place Right Arm Panel (B1) onto the assembled frame from Step 2.
- Step 3.1: Align the dowels of Support Bar (E1) into the positions in the Right Arm Panel (B1).
- Then, affix Support Bar (E1) with Right Arm panel (C1) by using Bolt (1) and Allen Key (3).
- Step 3.2: Attach the Right Arm Panel (B1) onto Backrest Panel (A1) by using Bolts (1) and Allen Key (3).

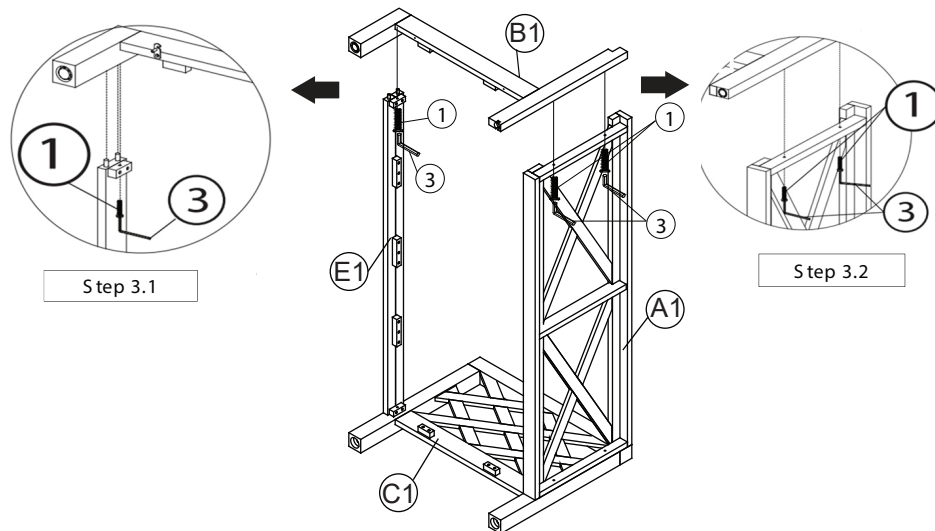

3 Attaching the chaise seat to the back

- Attach the Seat Panel (D1) into the Left Chair as shown in picture above.
- Affix Seat Panel (D1) with Left Chair by using Screws (2) and Allen Key (3).
- Note: Using Screws (2) from inside to outside of Seat Panel (D1).

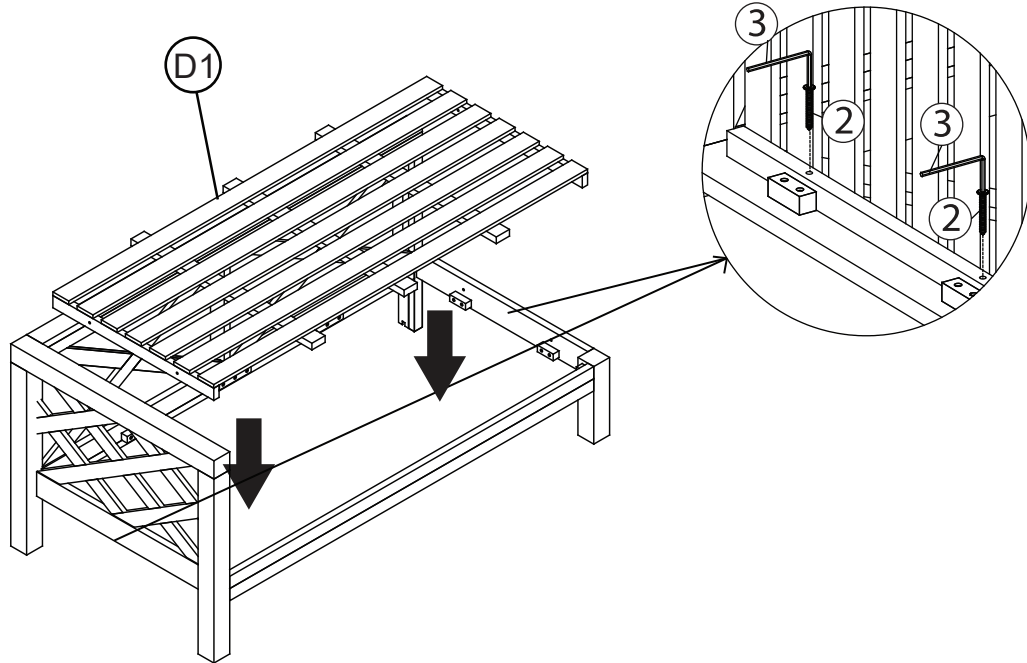

4 Attaching the armrest to the seat

- Inspect the Left Chair and make sure all parts are adequately connected..
- In a sequential manner, tighten all Screws and Bolts at all joints.

With assistance from your adult partners, adjust the Levellers to desired height to avoid wobbles.

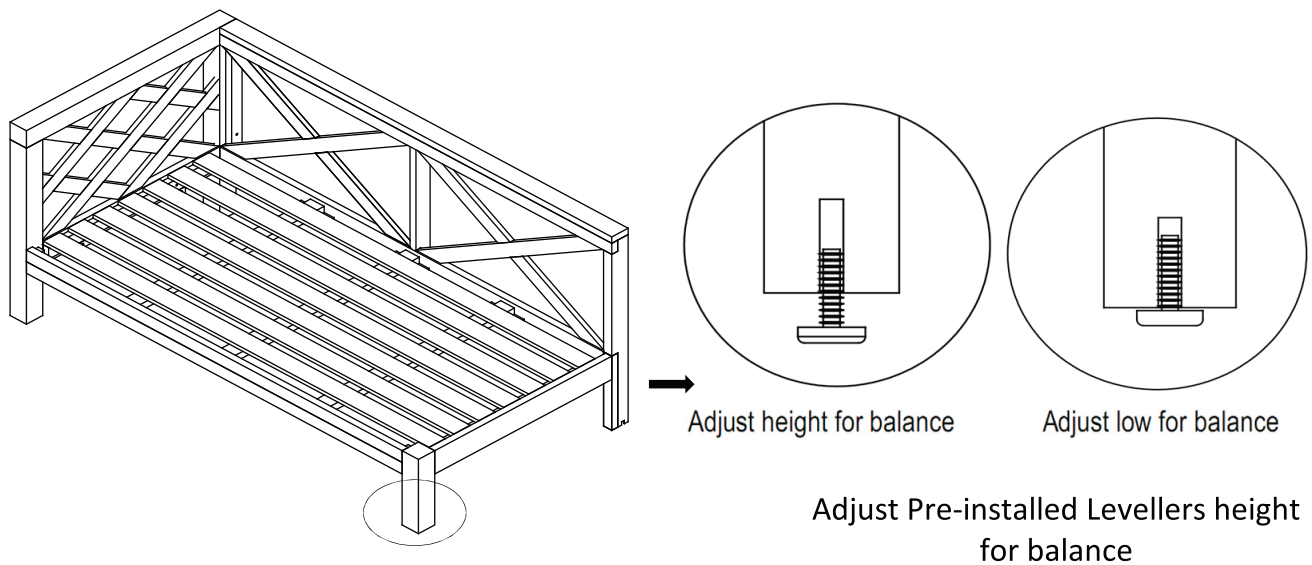

5 Attaching the chaise seat to the back

- Place Seat Cushion (F1), Left Back Cushion (G1) and Right Back Cushion (G1) to Seat Panel (D1).

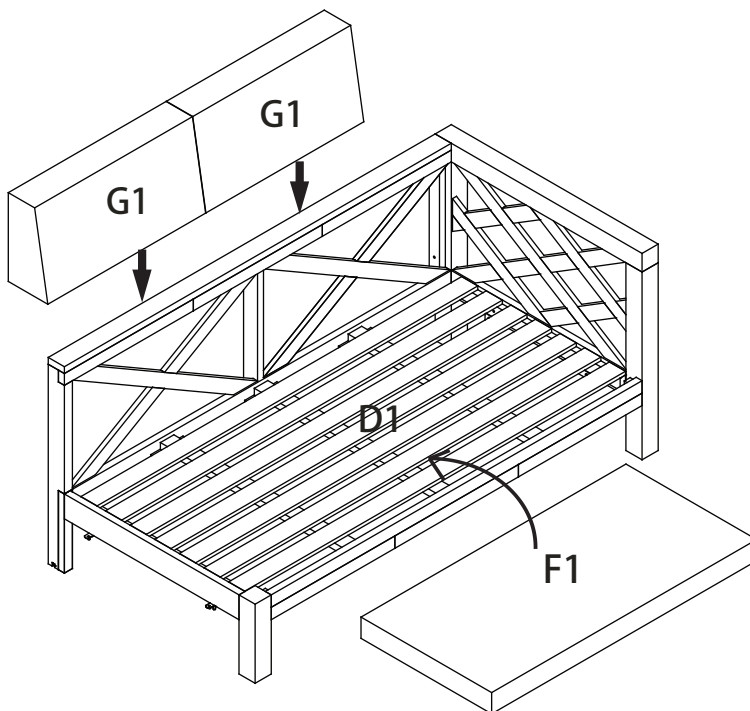

6 Attaching the armrest to the seat

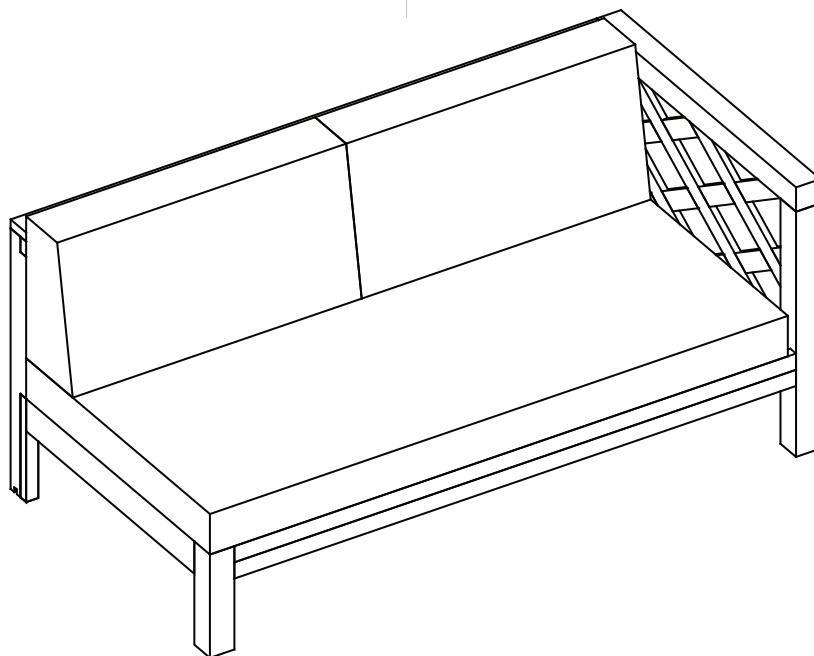

PACKAGE CONTENTS

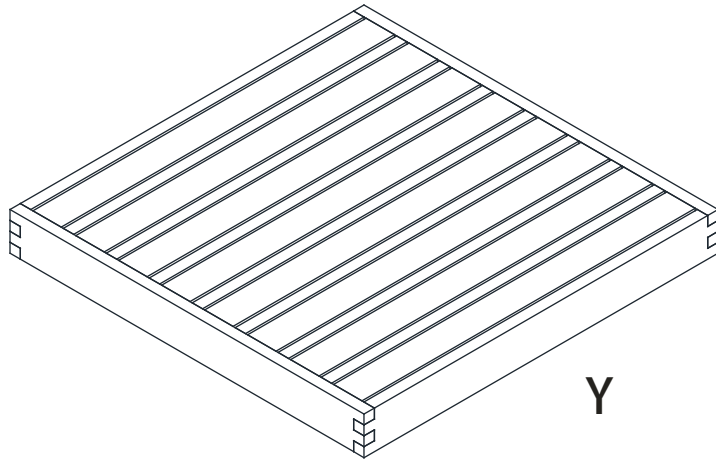

Y

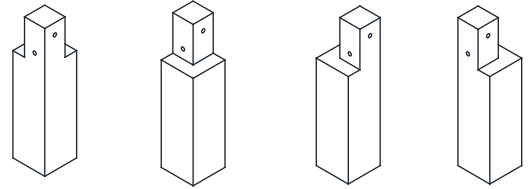

Z

Part	Description	Quantity
Y	Table top	1
Z	Legs	4

HARDWARE INCLUDED

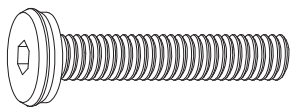

(1)



(2)



(3)

Part	Description	Quantity
(1)	Bolt M6x55mm	9
(2)	Flat Washer M6xD1.5mm	9
(3)	Hex wrench 4mm	1

1 Attaching the legs to the top

- Place the Table Top (Y) with its underside skywards onto a clean, soft surface to avoid any scratch or damage to the product.
- Affix loosely the Legs (Z), and into the mounting position at the corners of the Table Top (Y), using the Bolts (1) with Flat Washers (2)), with the Allen Key(3), as shown above.
- Repeat the same process with the other Leg (Z).

CAUTION: When tightening these screws, tighten sequentially. DO NOT tighten any screw fully and then towards the next one. This would cause the frame to warp.

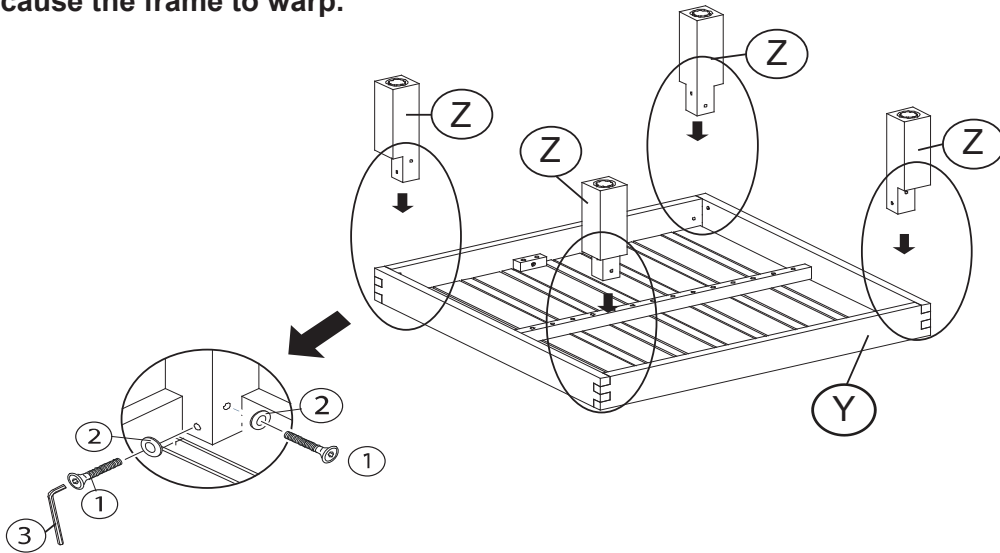

2 Completing the assembly

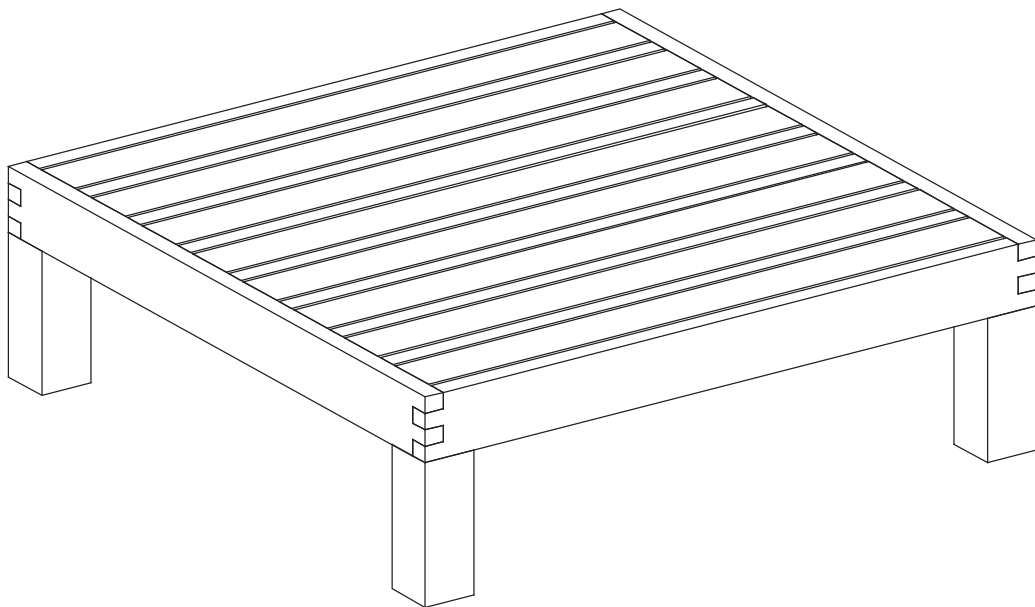

Care and Cleaning

- Before using, wipe with a clean, dry cloth. Do not use bleach or solvents. When not in use, store furniture in a cool, dry place. If your set includes cushions or mesh fabric, they may be cleaned by hand with a mild solution of soap and water.
- Rinse cushion thoroughly and allow to drip dry. Do not machine wash or tumble dry, as cushions may shrink.
- Do not use bleach or solvents on fabrics. When cleaning the table top make sure to use a soft, clean cloth that does not bleed color as well.

Care and Maintenance

- Wash the frame with a mild solution of soap and water, rinse with clean water, and dry thoroughly.
- Cushions may also be cleaned by hand with a mild solution of soap and water. Rinse the cushion cover thoroughly and allow to drip dry. The back cushion and pillow should be spot cleaned with a soft cloth. Do not machine wash or tumble dry, as cushions may shrink. Do not use bleach or solvents on fabrics. Never use cleaners that contain acid or abrasive materials.
- Use and operation: To improve the lifespan of this furniture, cover when not use and store in a dry place in the off season.