



# SHOREDOCKER

## ASSEMBLY AND OPERATING INSTRUCTIONS FOR BASE MODEL / EXTENSION



**WARNING:** The watercraft ramp you have purchased has certain hazards associated with its use. Never stand behind a watercraft while it is on the ramp.

Never allow anyone in or on the watercraft while it is on the ramp.

Never allow anyone to operate the ramp unless they are familiar with all of the instructions and warnings contained herein.

Never try to stop a free wheeling winch handle. (Always keep a firm grip on the handle while the ratchet pawl is not fully engaged.)

Never allow watercraft to roll free down the ramp. Injury may occur or damage to watercraft or ramp may occur.

Before beginning, read the entire Assembly and Operating instructions to determine the suitability of this kit for your application.

Congratulations on the purchase of your ShoreDock<sup>®</sup> watercraft ramp. The following instructions provide guidelines for the construction of your model. Remember that with a little planning you may customize this kit to work perfectly for you situation. The Base / Extension model is designed for small boats **and personal watercraft (PWCs, Jet Skis etc)**. \*Not to exceed 800 pounds (watercraft,motor,fuel,gear) as sold in kit. Additional roller sets can be purchased and added to increase ramp capacity. Estimate one roller set per 100 pound increase in boat weight up to 1200 Lbs.

### PARTS LIST FOR Base Model / Extension

16	Wheel Brackets	16	Galv 2.5" x 3/8" Hex Bolts
8	Non Marking 3.5" Polyurethane Wheels	8	SS 2.5" x 3/8" Hex Bolt
8	Bushing	8	SS 3/8" Lock nuts
4	Side Braces	8	Galv 2.5" x 3/8" Carriage Bolts
1	Drill Template	24	Galv 3/8" nuts
1	Assembly Instruction	24	Galv 3/8" lock washers
12	Coated Deck Screws		

\*\* If building a ramp for a PWC, see the important note about width on page 2 before beginning construction.

#### \*\*Suggested Lumber

2 ea. Pressure Treated 2" x 6" x 12'

4 ea. Pressure Treated 2" x 6" x 4'

#### \*\*Optional additional ShoreDock Accessories

Winch Kit (Includes R & L Winch post supports, 1100# winch, Hardware)

RS1200 (additional roller sets)

First you will build the basic framework.

**STEP 1:** DETERMINE THE LENGTH AND LUMBER DIMENSIONS NEEDED. You will likely want to store your watercraft all the way out of the water and away from any wave action. Also remember that a few feet of the ramp will extend into the water so that the rollers first engage the hull *below* the bow. For the side rails or main supporting beams it is recommended that you use 2 x 6s with 2 x 4s for the cross members. Use pressure treated lumber for longer life. If possible use single length boards for the side rails. If you must join lengths end-to-end, instructions for doing so are included at the end of the assembly instructions.

**IMPORTANT:** The dimensions are guidelines only. They will depend in part if the ramp will be spanning more than a few feet or will be largely supported on the ground. The side rails must be strong enough so as not to deflect much from the weight of the boat. This is especially important when lowering the boat into the water with longer ramps. If the side rails deflect, the boat transom may hang up on the rollers directly behind it. **NEVER TRY TO FREE A HUNG UP BOAT FROM BEHIND. ALWAYS TAKE OUT SLACK FROM THE WINCH HANDLE AND HAVE THE WINCH MANNED WHEN FREEING BOAT!** The best way to eliminate deflection of the ramp is by using supporting blocks or installing supporting legs as outlined below.

**STEP 2:** DETERMINE THE WIDTH of the ramp you need. By looking at the shape of your hull at the transom, decide where you want the rollers to align. Consider having the rollers fall in line with a flatter area of the hull. Support need **not** be as wide as on a boat trailer as there are not the same side forces as encountered on the open road. **IMPORTANT:** Consider that a narrower spacing of the rails will help when loading your boat onto the ramp. The bow will be less likely to bottom out on the ground or cross members as the boat starts to angle up to the ramp.

**IMPORTANT:** Consider leaving the cross members *longer* than needed for a couple of reasons. You may want the wider support especially if on uneven ground and/or blocking is necessary and secondly, you may change your mind and change the side rail spacing. (In that case you would need to re-cut another winch post base).

**STEP 3:** Cut the boards and assemble the cross members to the rail as shown. If you choose to mount the side braces on the outside of the rails, the cross members should extend a minimum of 6 inches beyond the rails.

You may want to cut an angle out of the water end of the side beams as shown below, but it isn't necessary. If you do, attach the end cross member a few inches from the end so that the top of the side brace makes full contact with the side rail. Attach all of the end cross members first and then equally space the remaining cross members. Use the 2 1/2 inch screws provided.

Install the side braces. Hold or clamp them in place to drill 3/8" holes through the side rails and cross-members. Attach using 3/8" x 2 1/2" carriage bolts, nuts and lock washers.

### Inside or Outside?

Mounting the side braces on the outside of the rails will provide some additional strength, but mounting to the inside results in a more "compact" ramp that will be slightly lighter

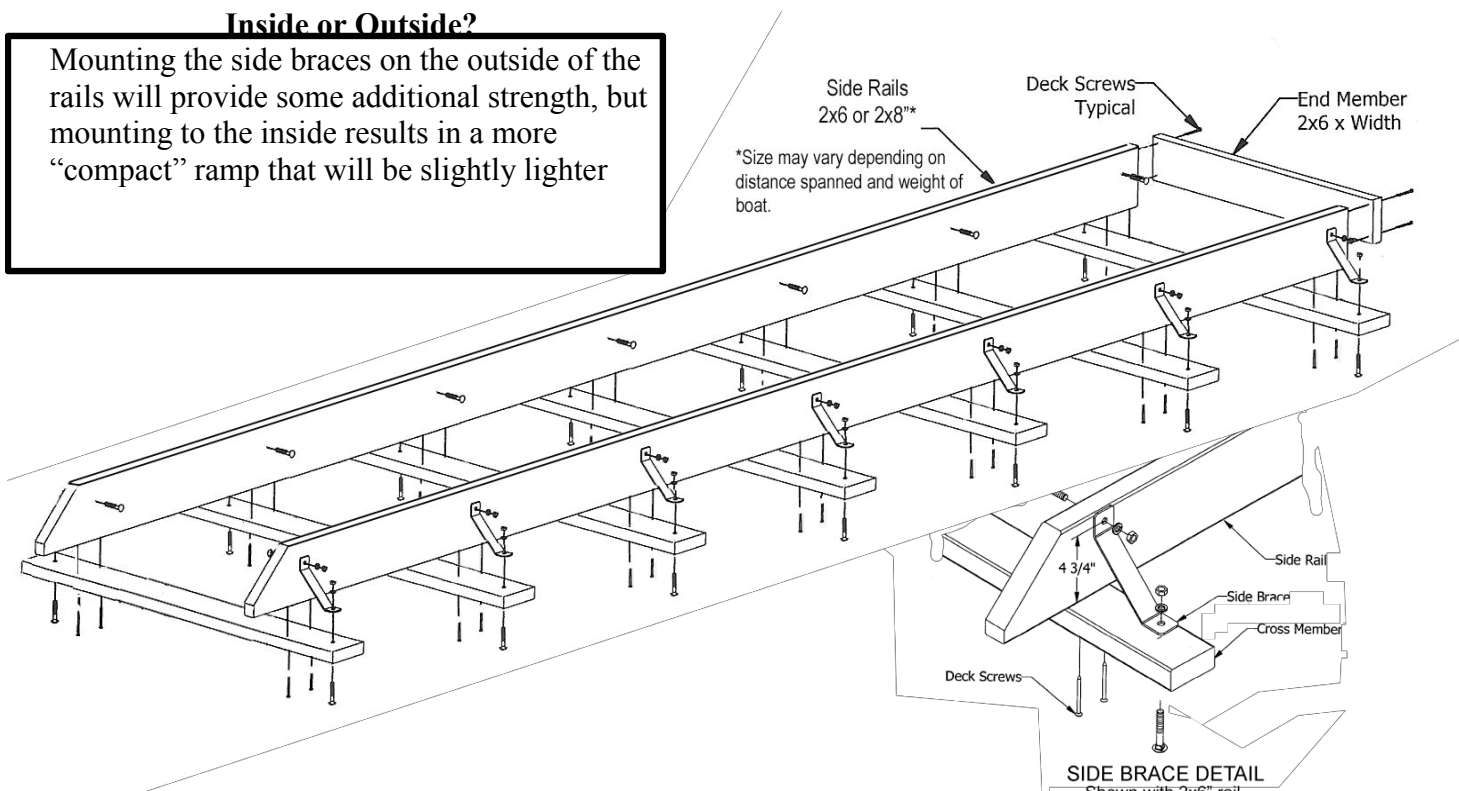

**STEP 4:** Install roller assemblies as shown. Assemble as shown in the figures below. Consider the following criteria when selecting the location of the roller assemblies:

- a. Assemblies should obviously be in pairs, i.e. identical location on *both* the right and left rail.
- b. The first pair (from the water end of the ramp) should be close to the water end of the rail.
- c. Roller assembly pairs should be spaced more closely together where watercraft weight is greater. Pay particular attention those areas below the motor. If you have constructed a ramp with extended length be aware that a heavy stern may pass over several feet of the ramp. Additional roller assemblies are available for purchase.
- d. Generally speaking, your watercraft will be totally supported over the aft 2/3s to 3/4s of the hull. This is because the bow starts sloping upward and also the weight of the motor results in a center of gravity more toward the stern.
- e. Use the template to mark the hole locations and drill small pilot holes, followed by a 3/8" or slightly larger hole. Try to drill at a perpendicular angle to the face of the board. Many drills come with a square angle guide.

### ShoreDocker Base Model Roller Assembly

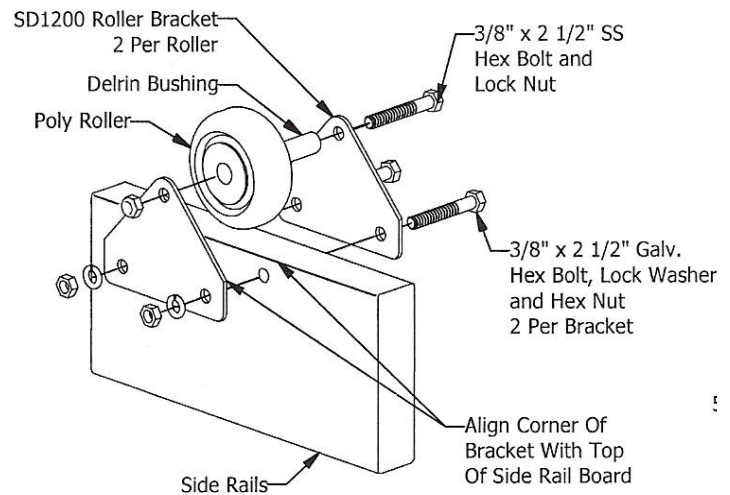

Model SD1200 Roller Assembly

### ATTACHING SUPPORTING LEGS

- Concrete Blocks work best for supporting or "leveling" your ramp.
- Extra long cross members can help make the ramp more stable.
- Keep leg height to a minimum. Shore Docker is not responsible for customized designs. Be safe!
- Keep legs VERTICAL TO THE HORIZON regardless of the ramp angle.

Install legs as shown below. (Hardware not included)

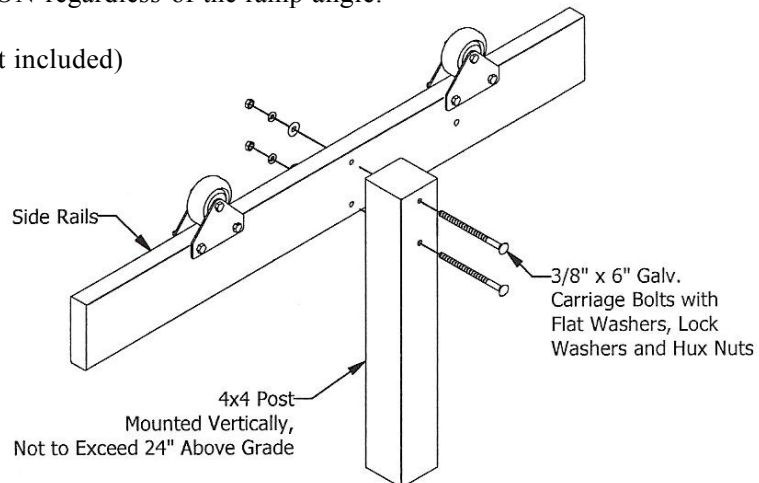

### Adding Support Legs

Note: This optional hardware not included in kit.

## **SETTING UP AND OPERATION OF SHORE DOCKER BOAT RAMP**

**Because Shore Docker is a kit, you are responsible for the safe construction, setup and operation of your ramp. Shore Docker only supplies parts and general guidelines. There are many types of boats and shorelines. You must make the decision of the suitability of this kit for your situation.**

Locate the ramp with the water end deep enough to easily engage your hull. Hook the end of the winch cable to the eye on your bow. Read the literature supplied with the winch before operating.

- Read all warnings on page one.
- Never drive the boat onto ramp. The boat must be cranked up.
- Never release handle or let winch free-wheel when lowering boat. Always crank boat down.

### **WARRANTY**

The manufacturer warrants for a period of one year from the date of purchase, the workmanship of all parts. The warranty is limited to the repair and/or replacement of parts ShoreDocker parts only. The manufacturer does not warrant the suitability of this product for any specific or general application. All warranty claims must be submitted to the manufacturer, not the reseller. Claims must include the damaged parts and a copy of the original sales receipt, postage prepaid.

*Manufactured by:  
Innovative Marine Systems  
1799 County Road 90 North  
Maple Plain, MN 55359  
1-866-876-5548  
www.shoredocker.com*

© 2006-2011 Innovative Marine Systems All Rights Reserved.