

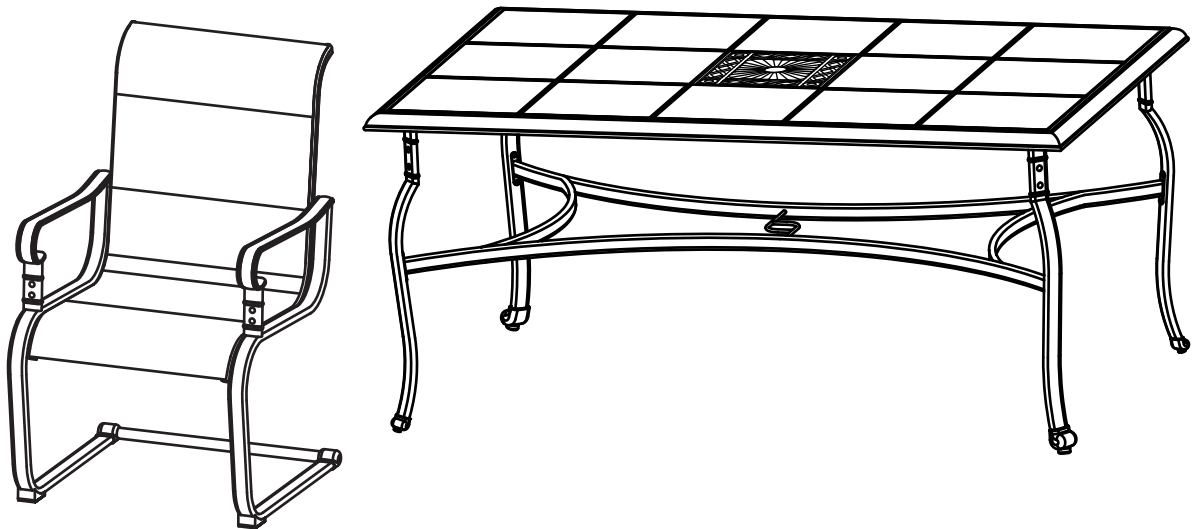

Item #1001 845 561
Model #FCS80198CST

USE AND CARE GUIDE

BELLEVILLE 7-PIECE C-SPRING DINING SET



Questions, problems, missing parts? Before returning to the store,
call Hampton Bay Customer Service.
8 a.m. - 7 p.m., EST, Monday - Friday, 9 a.m. - 6 p.m., EST, Saturday

1-855-HD-HAMPTON

HAMPTONBAY.COM

THANK YOU

We appreciate the trust and confidence you have placed in Hampton Bay through the purchase of this dining set. We strive to continually create quality products designed to enhance your home. Visit us online to see our full line of products available for your home improvement needs. Thank you for choosing Hampton Bay!

Table of Contents

Table of Contents.....	2	Chair Assembly	5
Warranty.....	2	Table Assembly	7
What is Covered.....	2	Care and Cleaning	9
What is Not Covered	2		
Pre-Assembly.....	2		
Planning Assembly	2		
Hardware Included	2		
Chair Package Contents	3		
Table Package Contents	4		

Warranty

2 YEAR FRAME AND 2 YEAR LIMITED FABRIC WARRANTY

WHAT IS COVERED

We warrant the frames to be free of manufacturing defects to the original purchaser for two years, and a two year limited warranty for the fabric.

WHAT IS NOT COVERED

It remains the customer's responsibility for freight and packaging charges to and from our service center. This warranty does not cover commercial use, hardware, acts of nature, fire, freezing, and abusive use. In addition, purchased parts are not covered under this warranty. We reserve the right to make substitutions with similar merchandise, if the model in question is no longer in production. We do not cover stretching of sling material that may occur over two years time under normal usage.

Contact the Customer Service Team at 1-855-HD-HAMPTON or visit www.HamptonBay.com

Pre-Assembly

PLANNING ASSEMBLY

Read all instructions before assembly.

To avoid damaging this product, assemble it on a soft, non-abrasive surface such as carpet or cardboard.



NOTE: More than one person may be required to complete the assembly of this product.

HARWARE INCLUDED



NOTE: Hardware not shown to actual size.



AA



BB



CC



DD



EE

Part	Description	Quantity
AA	M6x20 combination bolt	32+1
BB	M6x30 combination bolt	12+1
CC	M6x25 bolt	12+1
DD	M6x15 combination bolt	8+1

Part	Description	Quantity
EE	Hex wrench	3

Pre-Assembly (continued)

CHAIR PACKAGE CONTENTS

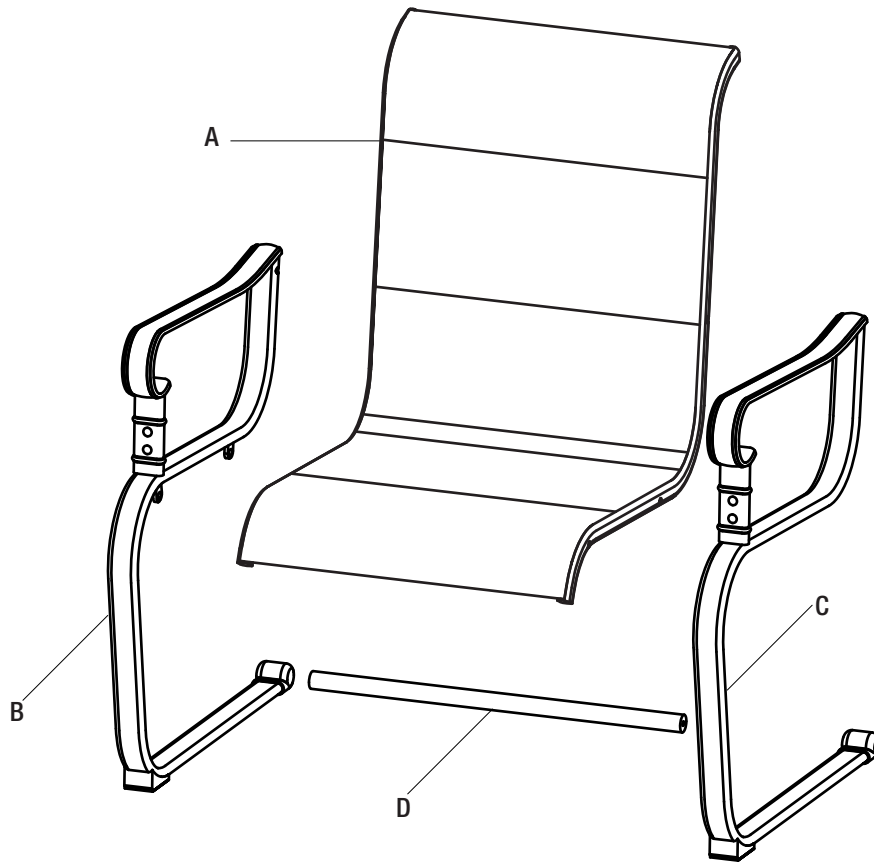

Part	Description	Quantity
A	Chair back	6
B	Right arm	6
C	Left arm	6
D	Back bar	6

Pre-Assembly (continued)

TABLE PACKAGE CONTENTS

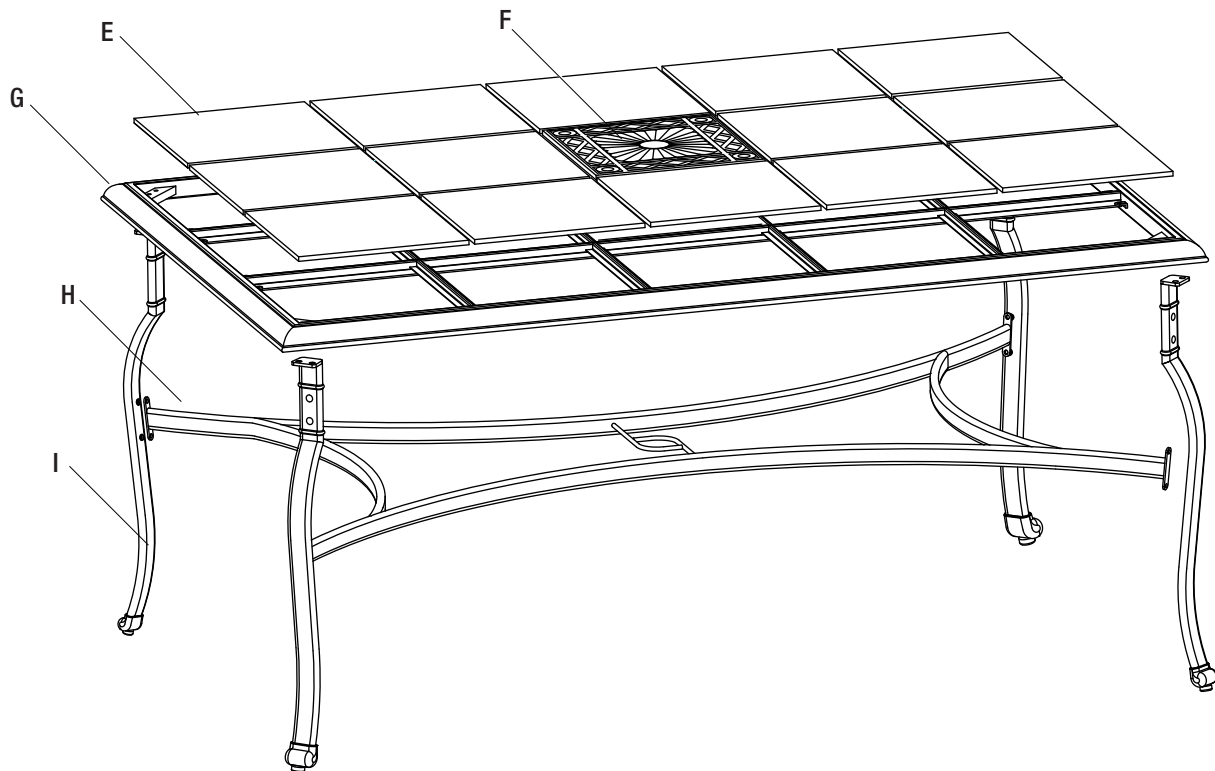

Part	Description	Quantity
E	Tile	15
F	Stamped metal	1
G	Table rim	1
H	Leg connector	1
I	Table leg	4

Chair Assembly

1 Connecting the chair back to the chair arms

- Attach the chair back (A) to the right arm (B) using M6x20 combination bolts (AA) and M6x30 combination bolts (BB), as shown below.
- Place the back bar (D) into the right arm (B).
- Repeat this step for the left arm (C).



NOTE: Loosely tighten all bolts using the hex wrench (EE).

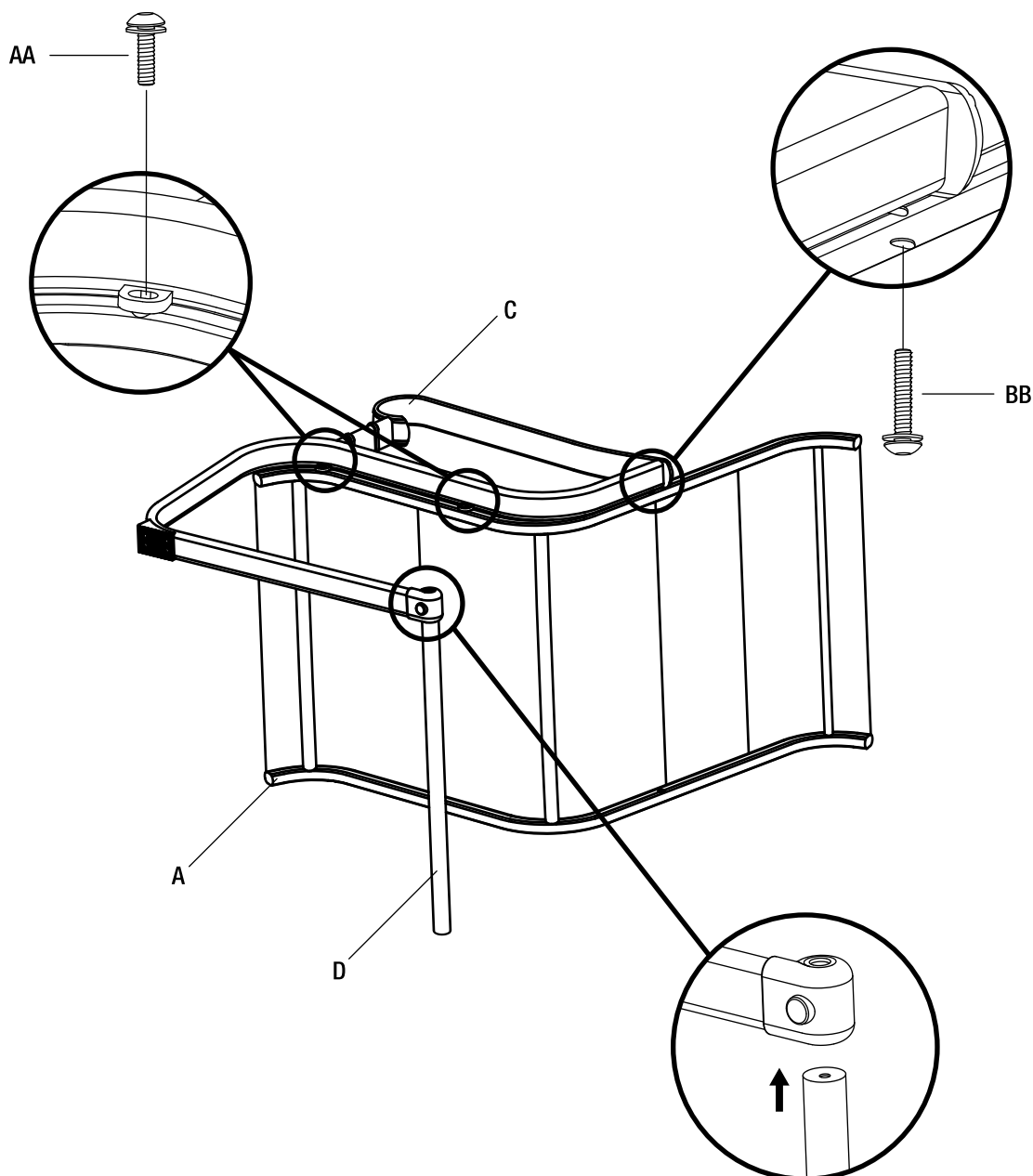

Chair Assembly (continued)

2 Securing the back bar

- Attach the back bar (D) to the chair arms (B and C) using the M6x25 bolts (CC).
- Tighten all of the bolts. Check and ensure the chair is tightly assembled and stable before use.

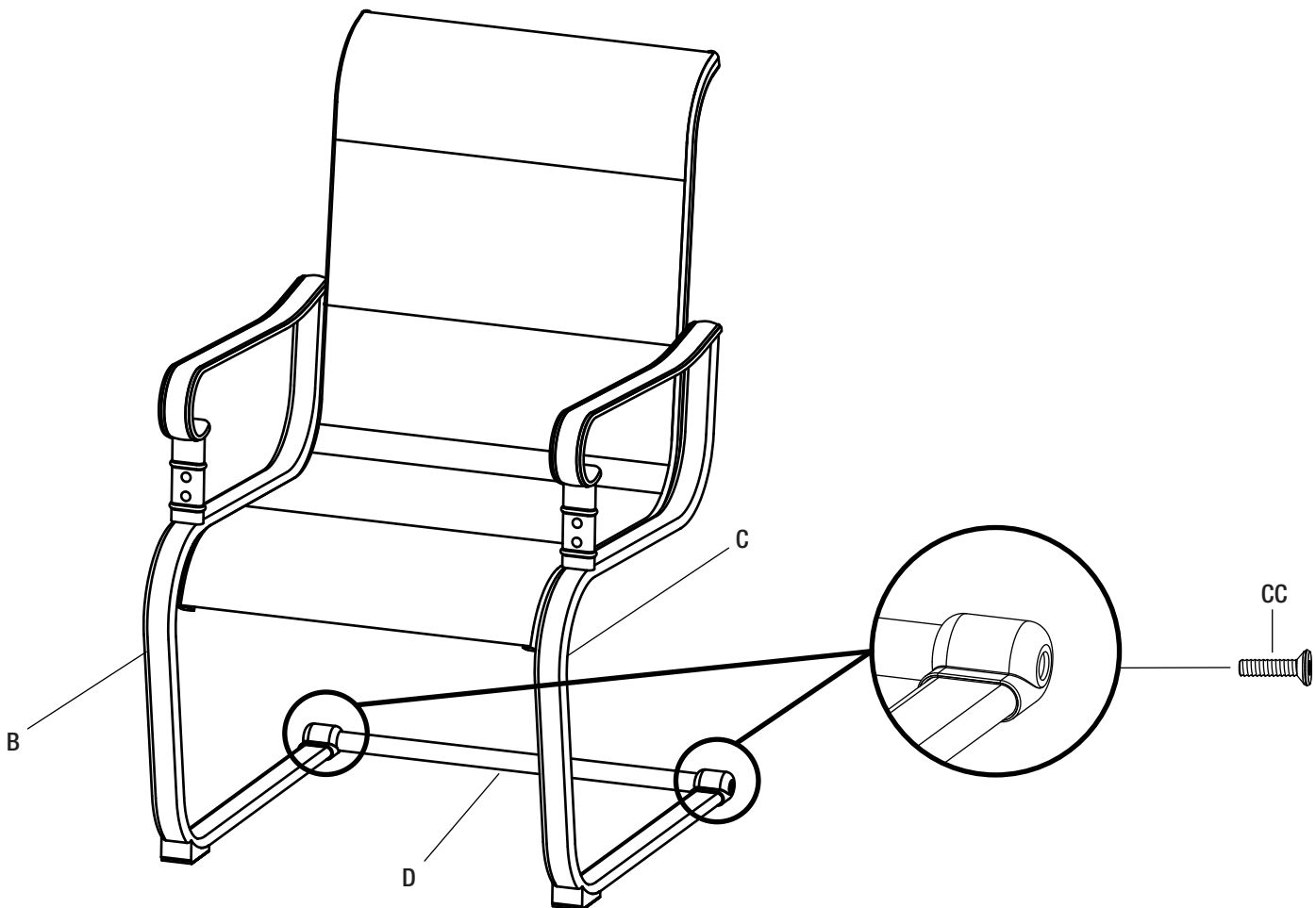

Table Assembly

1 Connecting the table legs

- Place the table rim (G) upside down on a soft surface.
- Attach each of the table legs (I) to the table rim (G) with M6x20 Combination bolts (AA).



NOTE: Loosely tighten all bolts using the hex wrench (EE).

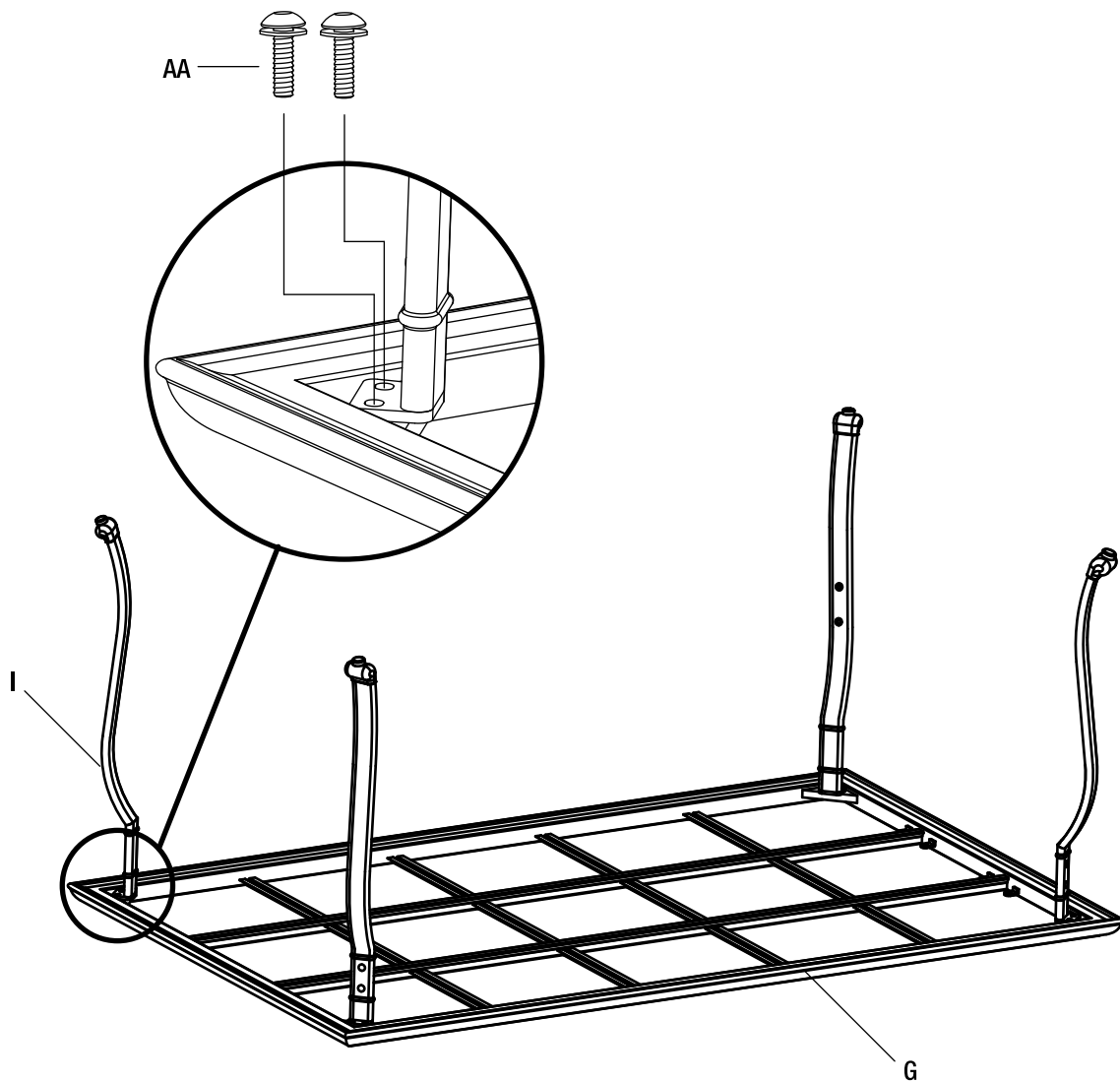

Table Assembly (continued)

2 Connecting the leg connector to the table legs

- Align the holes of the leg connector (H) with the holes on the inside of each table leg (I).
- Attach the leg connector (H) to the table legs (I) using M6x15 combination bolts (DD).



NOTE: Tighten all bolts using the hex wrench (EE).

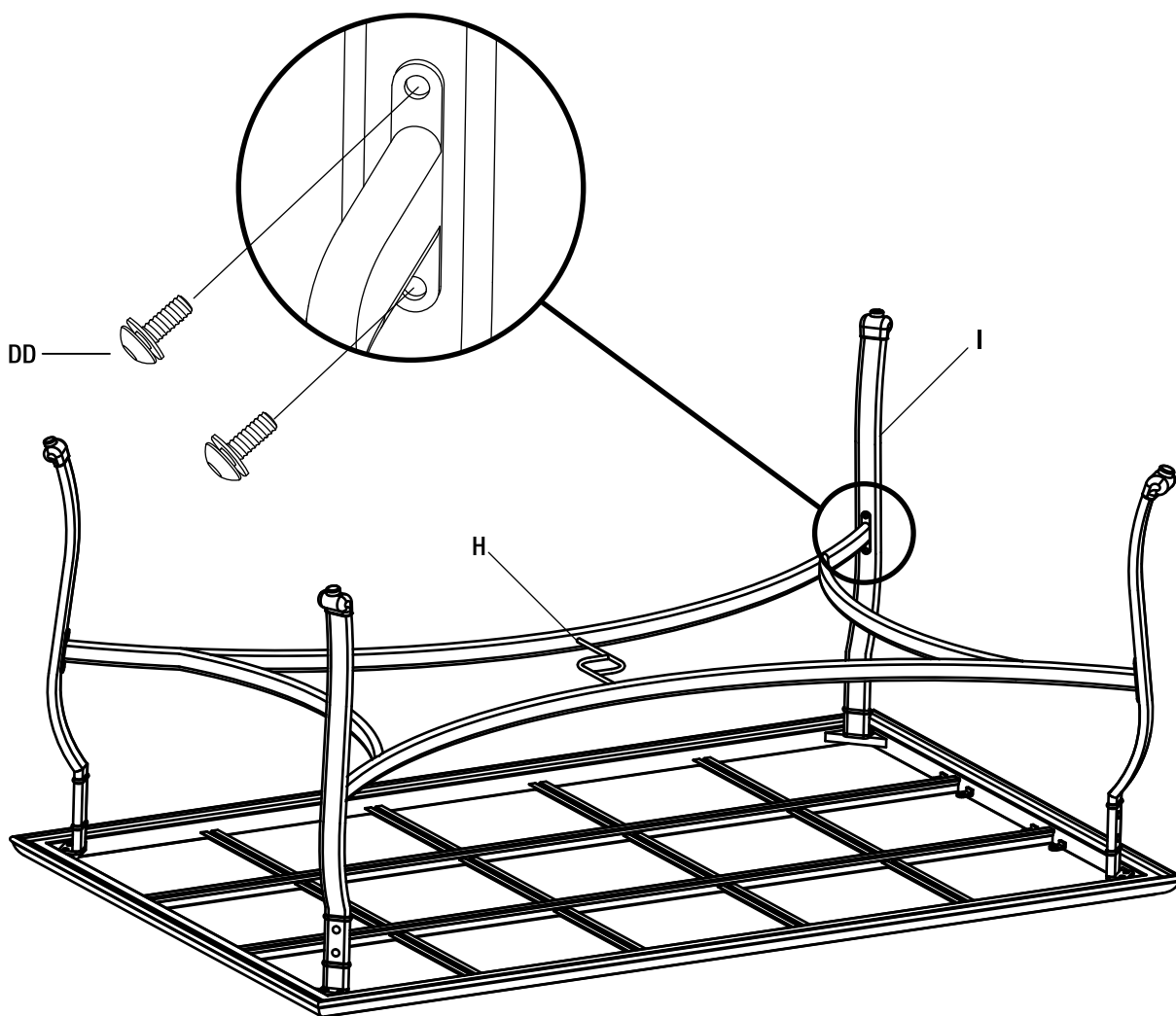

Table Assembly (continued)

3 Adding the tiles

- Turn the table right side up.
- Ensure all connections are secure.
- Carefully place the tiles (E) and stamped metal (F) onto the table rim (G).



NOTE: The stamped metal (F) can be replaced by the tile (E) if desired.

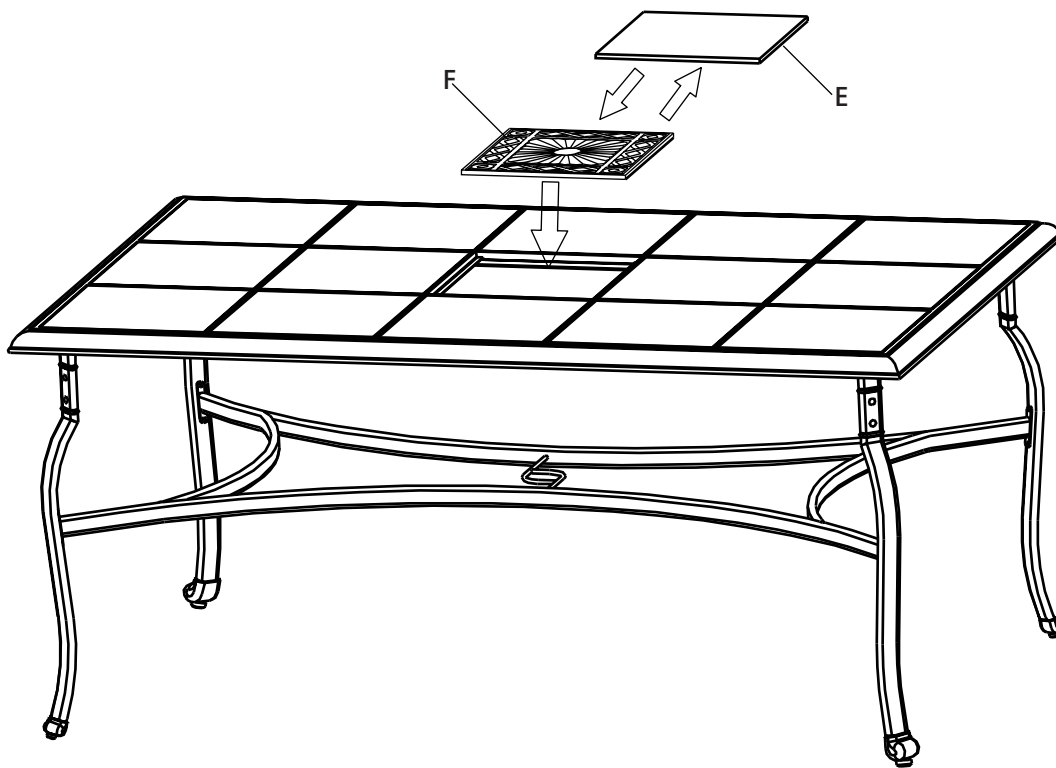

Care and Cleaning

- For best results, clean the frames with a damp cloth and dry thoroughly. This will help prevent mildew by removing dirt particles that may accumulate.
- Do not clean with abrasive materials, bleach, or solvents.
- Store the set in a dry, sheltered place when not in use.
- Keep the set away from fire, extreme heat, freezing conditions, and inclement weather such as rain, hail, sleet, snow, or wind.



Questions, problems, missing parts? Before returning to the store,
call Hampton Bay Customer Service.
8 a.m. - 7 p.m., EST, Monday - Friday, 9 a.m. - 6 p.m., EST, Saturday

1-855-HD-HAMPTON

HAMPTONBAY.COM

Retain this manual for future use.