

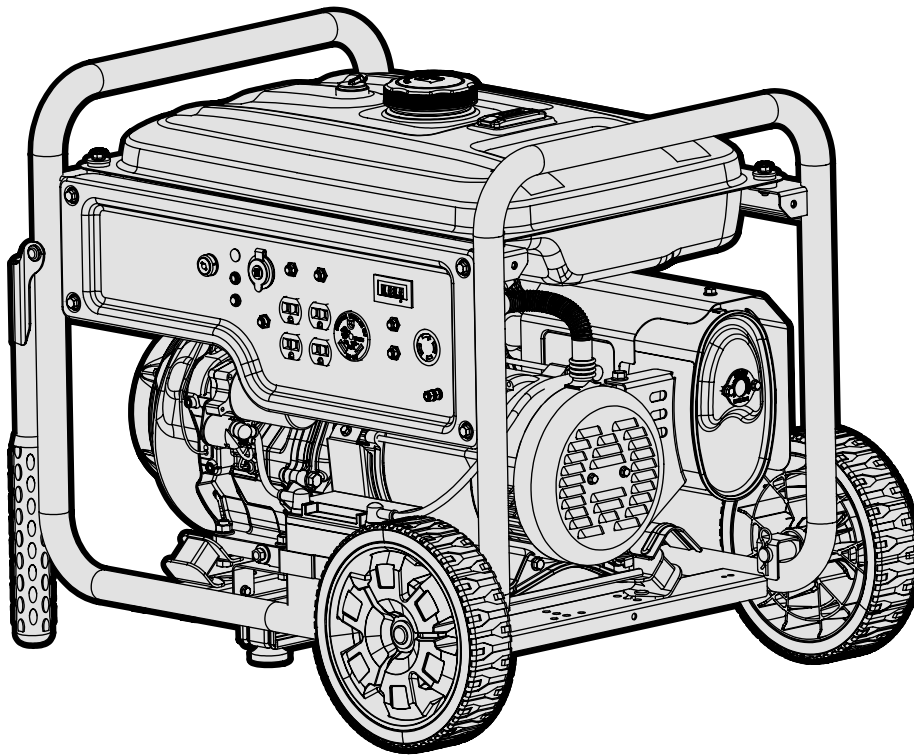

**MODEL GN9500**

# **9500W PORTABLE GENERATOR**

**Instruction Manual**



## **NEED HELP? CONTACT US!**

Have product questions? Need technical support? Please feel free to contact us:



**1-800-232-1195 (M-F 8AM-5PM CST)**



**TECHSUPPORT@WENPRODUCTS.COM**

**IMPORTANT:** Your new tool has been engineered and manufactured to WEN's highest standards for dependability, ease of operation, and operator safety. When properly cared for, this product will supply you years of rugged, trouble-free performance. Pay close attention to the rules for safe operation, warnings, and cautions. If you use your tool properly and for its intended purpose, you will enjoy years of safe, reliable service.

For replacement parts and the most up-to-date instruction manuals, visit **WENPRODUCTS.COM**

# CONTENTS

<b>WELCOME</b>	<b>3</b>
Specifications.....	3
Introduction .....	4
<b>SAFETY</b>	<b>5</b>
Safety Information .....	5
Generator Safety Warnings .....	6
<b>BEFORE OPERATING</b>	<b>9</b>
Unpacking & Packing List.....	9
Know Your Generator.....	10
Assembly & Adjustments.....	12
Generator Preparation.....	13
<b>OPERATION &amp; MAINTENANCE</b>	<b>18</b>
Starting Your Generator .....	18
Using Your Generator.....	22
Shutting Off Your Generator.....	26
Maintenance.....	27
Transportation & Storage.....	33
Troubleshooting Guide.....	34
Wiring Diagram.....	36
Exploded View & Parts List.....	37
Warranty Statement .....	43

To purchase accessories for your tool, visit **WENPRODUCTS.COM**

**Generator Cover** (Model 56409), and **High Altitude Kit** (Model GN9500-HA36 & GN9500-HA68)

# SPECIFICATIONS

## GENERATOR

Rated Wattage	7500 Watts
Surge Wattage	9500 Watts
Rated Voltage	AC: 120V / 240V
	DC: 12V
Rated Amperage	AC: 60A / 30A
	DC: 8.3A
Phase	Single
Frequency	60Hz
Product Dimensions	Length: 27.3 Inches
	Width: 20.8 Inches
	Height: 22.2 Inches
Product Net Weight	194 lbs (88 KG)

## ENGINE

Engine Type	4 Stroke, OHV, Single Cylinder with Forced Air Cooling System
Engine Displacement	420cc
Engine Speed	3600 RPM
Fuel Tank Capacity	6 gallons (23 L)
Oil Capacity	37.2 fl. oz. (1.1 L)
Half-Load Run Time	7.5 Hours
Lubrication System	Splash Lubrication
Spark Plug Type	Torch F6TC / NGK BP6ES
Spark Plug Gap	0.6 - 0.8mm (0.024 - 0.031 in)
Spark Plug Torque	15 - 20 Nm (11.06 - 14.75 ft-lb)
Battery	12V, 9Ah, lead-acid

# INTRODUCTION

Thanks for purchasing the WEN 9500-Watt Portable Generator. Refer to the illustration below for the location of the serial number on the side of the engine. Record the generator information in the spaces provided below. If assistance for information or service is required, please contact customer service by calling **1-800-232-1195**, M-F 8-5 CST; you will be asked to provide the following generator information when calling.

**Generator Model Number:** GN9500

**Date of Purchase:** \_\_\_\_\_

**Purchased From:** \_\_\_\_\_

**Serial Number:** \_\_\_\_\_

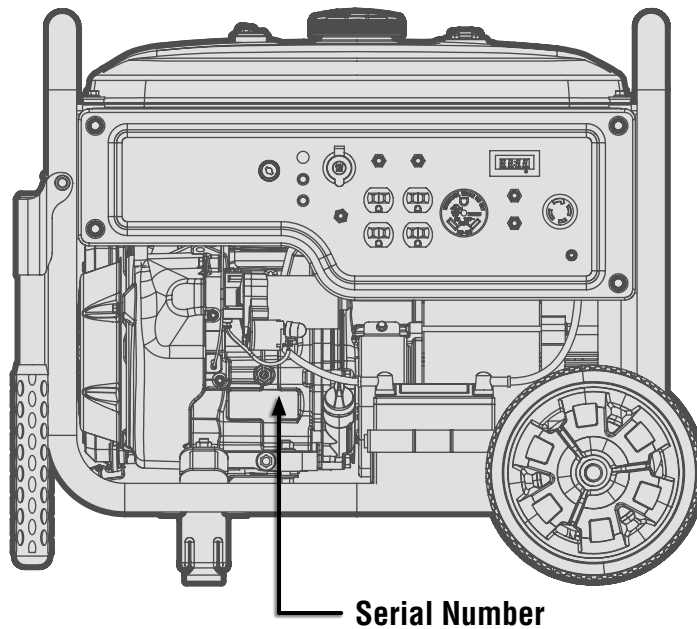

Serial Number

## SERVICE RECORD

Record the service dates of your generator in the chart below. Please perform maintenance checks and operations according to the “Maintenance” section of the manual.

Service Record	Date	Date	Date	Date	Date	Date
Change Oil						
Change Spark Plug						
Clean Fuel Tank						
Clean Air Cleaner						
Clean Spark Arrestor						

**TO MAXIMIZE THE LIFESPAN OF YOUR GENERATOR:** We recommend running your generator at least once a month for 20 to 30 minutes. Start the generator according to the instructions and plug a small load in to make sure the outlet is producing electricity.

# SAFETY INFORMATION

 **WARNING!** Before operating the generator, make sure to read all safety warnings and all instructions. Failure to follow the warnings and instructions may result in electric shock, fire or serious injury.

## SAFETY INTRODUCTION

Safety is a combination of common sense, staying alert, and knowing how your tool works. This manual contains important information regarding the generator's potential safety concerns, as well as preparation, operation, and maintenance instructions. Before operating this generator, be sure to read and observe all warnings and instructions both on the generator labels and in this instruction manual. Failure to follow all instructions listed below may result in personal injury.

**NOTE:** The following safety information is not meant to cover all possible conditions and situations that may occur. WEN reserves the right to change this product and specifications at any time without prior notice.

At WEN, we are continuously improving our products. If you find that your tool does not exactly match this manual, please visit [wenproducts.com](http://wenproducts.com) for the most up-to-date manual or contact customer service at **1-800-232-1195**, M-F 8-5 CST.

**Keep this manual available to all users during the entire life of the tool and review it frequently to maximize safety for both yourself and others.**

## SAVE THESE SAFETY INSTRUCTIONS.

## SAFETY SYMBOLS

The purpose of following safety symbols is to attract your attention to possible dangers. The safety symbols, and their explanations, deserve your careful attention and understanding. The safety warnings do not by themselves eliminate any danger. The instructions or warnings they give are not substitutes for proper accident prevention measures.

 **DANGER:** indicates a hazard, which, if not avoided, will result in death or serious injury.

 **WARNING:** indicates a hazard, which, if not avoided, could result in death or serious injury.

 **CAUTION:** indicates a hazard, which, if not avoided, might result in minor or moderate injury.

**CAUTION!** when used without the alert symbol, indicates a situation that could result in damage to the machine.

## NOTICE REGARDING EMISSIONS

Engines that are certified to comply with U.S. EPA emission regulations for SORE (Small Off Road Equipment), are certified to operate on regular unleaded gasoline, and may include the following emission control systems: (EM) Engine Modifications and (TWC) Three-Way Catalyst (if so equipped).

## QUESTIONS? PROBLEMS?

In order to answer questions and solve problems in the most efficient and speedy manner, contact customer service at **1-800-232-1195**, M-F 8-5 CST or email [techsupport@wenproducts.com](mailto:techsupport@wenproducts.com).

# GENERATOR SAFETY WARNINGS

## **DANGER! CARBON MONOXIDE**

Using a generator indoors **CAN KILL YOU IN MINUTES**. Generator exhaust contains carbon monoxide (CO). This is a poison gas you cannot see or smell. If you can smell the generator exhaust, you are breathing CO. But even if you cannot smell the exhaust, you could be breathing CO.





**NEVER** use a generator inside homes, garages, crawl spaces, or other partially enclosed areas. Deadly levels of carbon monoxide can build up in these areas. Using a fan or opening windows and doors does **NOT** supply enough fresh air. **ONLY** use a generator outside and far away from windows, doors, and vents. These openings can pull in generator exhaust.

Even if you use a generator correctly, CO may leak into the home. **ALWAYS** use a battery-powered or battery-backup CO alarm in the home. If you start to feel sick, dizzy, or weak after the generator has been running, move to fresh air **RIGHT AWAY**. See a doctor. You may have carbon monoxide poisoning.

 **WARNING! RISK OF EXPLOSION. HIGHLY FLAMMABLE:** This generator may emit highly flammable and explosive gasoline vapors, which can cause severe burns or even death, if ignited. A nearby open flame can lead to explosion even if not directly in contact with gasoline.

- Do not operate near open flame, heat, or any other ignition source. Do not smoke near the generator.
- Always operate on a firm, level surface.
- Always turn generator off before refueling. Allow generator to cool for at least 2 minutes before removing fuel cap. Loosen cap slowly to relieve pressure in tank.
- Do not overfill fuel tank. Gasoline may expand during operation. Do not fill to the top of the tank. Allow for expansion. Always check for spilled fuel before operating.
- If fuel spills, move the generator at least 30 feet away from the spill and wipe clean any spilled fuel before starting the engine.
- Empty fuel tank before storing or transporting the generator.

 **WARNING!** If this generator is used as a supply for a building's wiring system, the generator must be installed by a qualified electrician and connected to a transfer switch as a separately derived system in accordance with all applicable laws and electrical codes and the National Electrical Code, NFPA 70. The generator shall be connected to a transfer switch that switches all conductors excluding the equipment grounding conductor. The frame of the generator shall be connected to an approved grounding electrode.

 **CALIFORNIA PROPOSITION 65 WARNING:** This product contains chemicals and produces exhaust known to the State of California to cause cancer, birth defects and other reproductive harm. For more information, visit [www.P65Warnings.ca.gov](http://www.P65Warnings.ca.gov)

# GENERATOR SAFETY WARNINGS

 **WARNING!** Do not let comfort or familiarity with the product replace strict adherence to product safety rules. Failure to follow the safety instructions may result in serious personal injury.

## OPERATING ENVIRONMENT

**1. Using a generator indoors can kill you in minutes.**

Only use a generator outside and far away from windows, doors and vents.

**2. Do not smoke near the generator.**

**3. Do not operate near open flame, heat, or flammable materials.** This generator may emit highly flammable and explosive gasoline vapors, which can cause severe burns or even death if ignited. A nearby open flame can lead to an explosion even if it isn't directly in contact with gasoline.

**4. Do not expose the generator to rainy or wet conditions; doing so significantly increases the risk of electrical shock.** Never handle the generator, electronic devices, or any cord while standing in water, while barefoot, or when hands or feet are wet.

**5. Always operate the generator on a dry, firm, level surface.**

**6. The generator should have at least 5 feet of clearance from buildings or other equipment during operation.**

**7. Do not allow children or non-qualified persons to operate the generator.**

## GENERATOR PREPARATION

**1. Always ground the generator before using it to maximize safety** (see "Ground the Generator" section).

**2. Do not overfill fuel tank, as gasoline may expand during operation.** Do not fill to the very top of the tank. Leave room for gasoline expansion. Always check for spilled fuel before operating.

**3. If any part of the generator, electrical device or power cord is broken, damaged, or defective, make sure it is repaired or replaced before operation.** Service should only be performed by a qualified technician. Do not use receptacles or cords that show signs of damage, such as broken or cracked insulation.

**4. Use a ground fault circuit interrupter (GFCI) in highly conductive areas such as metal decking or steel work.** Extension cords with in-line GFCIs are recommended for these operations to maximize safety.

**5. If connecting the generator to a building's electrical system for standby power, you MUST consult a qualified electrician and install a transfer switch.** Such connections must comply with local electrical laws and codes. Failure to comply can create a back-feed, which may result in serious injury or death to utility workers.

**6. Never modify the generator in any way.** Modifying or using the machine for any other purpose for which it is not designed may result in serious injuries, machine damage and voiding of the warranty.

## GENERATOR OPERATION

**1. Only use the generator for its intended purposes.** Modifying or using the generator for operations for which it was not designed may cause hazards and personal injury.

**2. Do not touch bare wires or receptacles (outlets).**

**3. Do not exceed the wattage capacity of the generator by plugging in more electrical devices than the unit can handle.** This could damage the generator and/or connected electrical devices. Check the operating voltage and frequency requirements of all electrical devices prior to plugging them into the generator.

**Generator safety warnings continue on the next page.**

# GENERATOR SAFETY WARNINGS

 **WARNING!** Do not let comfort or familiarity with the product replace strict adherence to product safety rules. Failure to follow the safety instructions may result in serious personal injury.

**TO MAXIMIZE THE LIFESPAN OF YOUR GENERATOR:** We recommend running your generator at least once a month for 20 to 30 minutes. Start the generator according to the instructions and plug a small load in to make sure the outlet is producing electricity. If you do not run it often, it will greatly shorten the generator's lifespan and void the warranty.

4. **Allow generator to run for several minutes before connecting electrical devices.** Do not start or stop engine with electrical devices plugged in to the receptacles. Failure to do so could damage the generator and/or connected electrical devices.
5. **Do not turn on electrical devices until after they are connected to the generator.**
6. **Generators vibrate in normal use.** During and after the use of the generator, inspect both the generator as well as extension and power supply cords for damage resulting from vibration.
7. **Do not touch hot parts.** This generator produces heat when running. Temperatures near exhaust can exceed 150°F (65°C). Allow generator to cool down after use before touching engine or areas of the generator that become hot during use.
8. **Turn off all connected electrical devices before stopping the generator.**
9. **Always turn generator off before refueling.** Allow generator to cool for at least 2 minutes before removing fuel cap. Loosen cap slowly to relieve pressure in tank.
10. **Turn the engine switch to “OFF” position when the engine is not running.**
11. **Empty fuel tank before storing or transporting the generator.** Do not store generator or gasoline near furnaces, water heaters, or any other appliances that produce heat or have automatic ignitions. Store the generator and fuel away from sparks, open flames, pilot lights, heat and other sources of ignition.
12. **Always wash hands after handling generator.**

**CAUTION:** Misuse of this generator can damage it or shorten its lifespan.



# UNPACKING & PACKING LIST

## UNPACKING

With the help of a friend or trustworthy foe, such as one of your in-laws, carefully remove the generator from the packaging and place it on a sturdy, flat surface. Make sure to take out all contents and accessories. Do not discard the packaging until everything is removed. Check the packing list below to make sure you have all of the parts and accessories. If any part is missing or broken, please contact customer service at **1-800-232-1195** (M-F 8-5 CST), or email [techsupport@wenproducts.com](mailto:techsupport@wenproducts.com).

## PACKING LIST

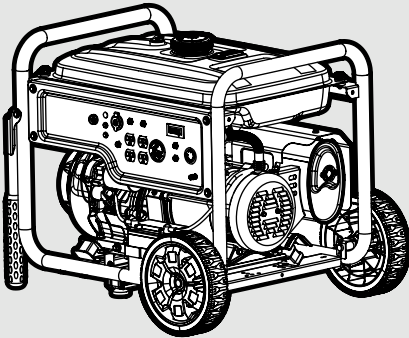
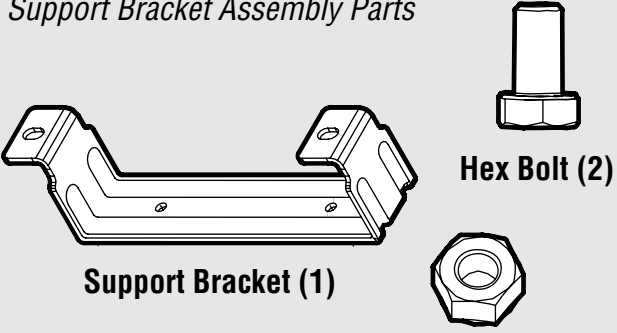
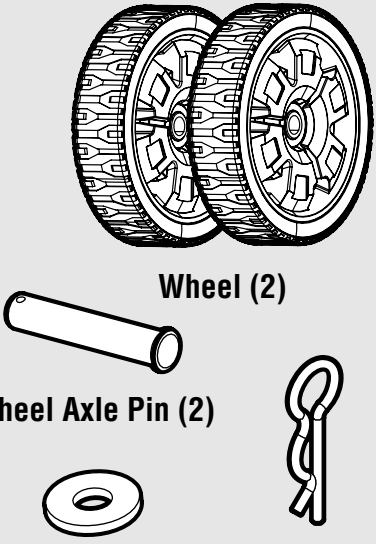
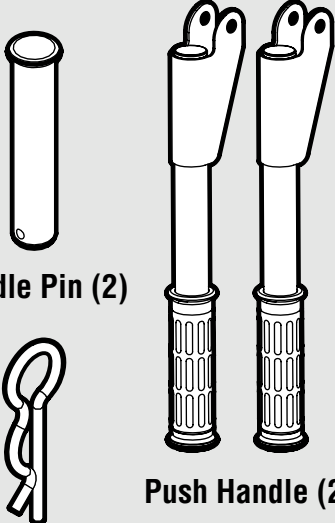
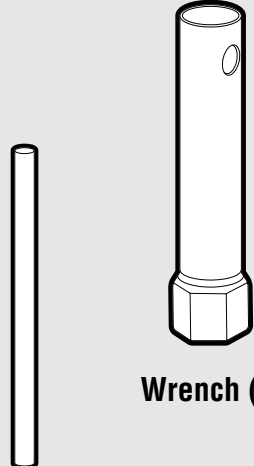
<p><i>Components</i></p>  <p><b>Generator (1)</b></p>	<p><i>Support Bracket Assembly Parts</i></p>  <p><b>Support Bracket (1)</b> <b>Hex Bolt (2)</b> <b>Hex Nut (2)</b></p>	
<p><i>Wheel Assembly Parts</i></p>  <p><b>Wheel (2)</b> <b>Wheel Axle Pin (2)</b> <b>Washer (2)</b> <b>R-Clip (2)</b></p>	<p><i>Handle Assembly Parts</i></p>  <p><b>Handle Pin (2)</b> <b>Push Handle (2)</b> <b>R-Clip (2)</b></p>	<p><i>Spark Plug Tools</i></p>  <p><b>Handle (1)</b> <b>Wrench (1)</b></p>

# KNOW YOUR GENERATOR

## TOOL PURPOSE

Generators provide you with power when and where you need it most. Refer to the following diagrams to become familiarized with all the parts and controls of your Generator. The components will be referred to later in the manual for assembly and operation instructions.

## GENERATOR

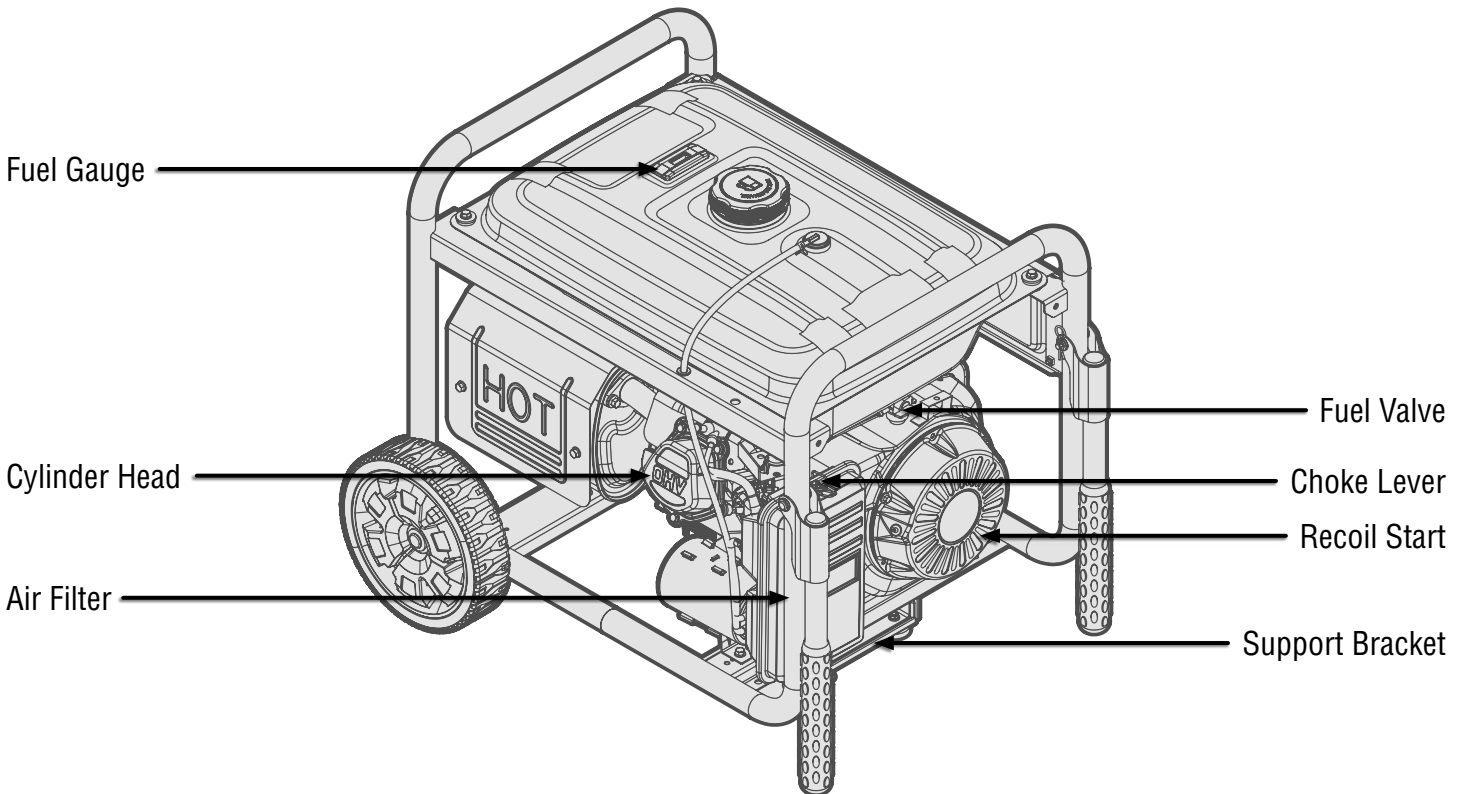
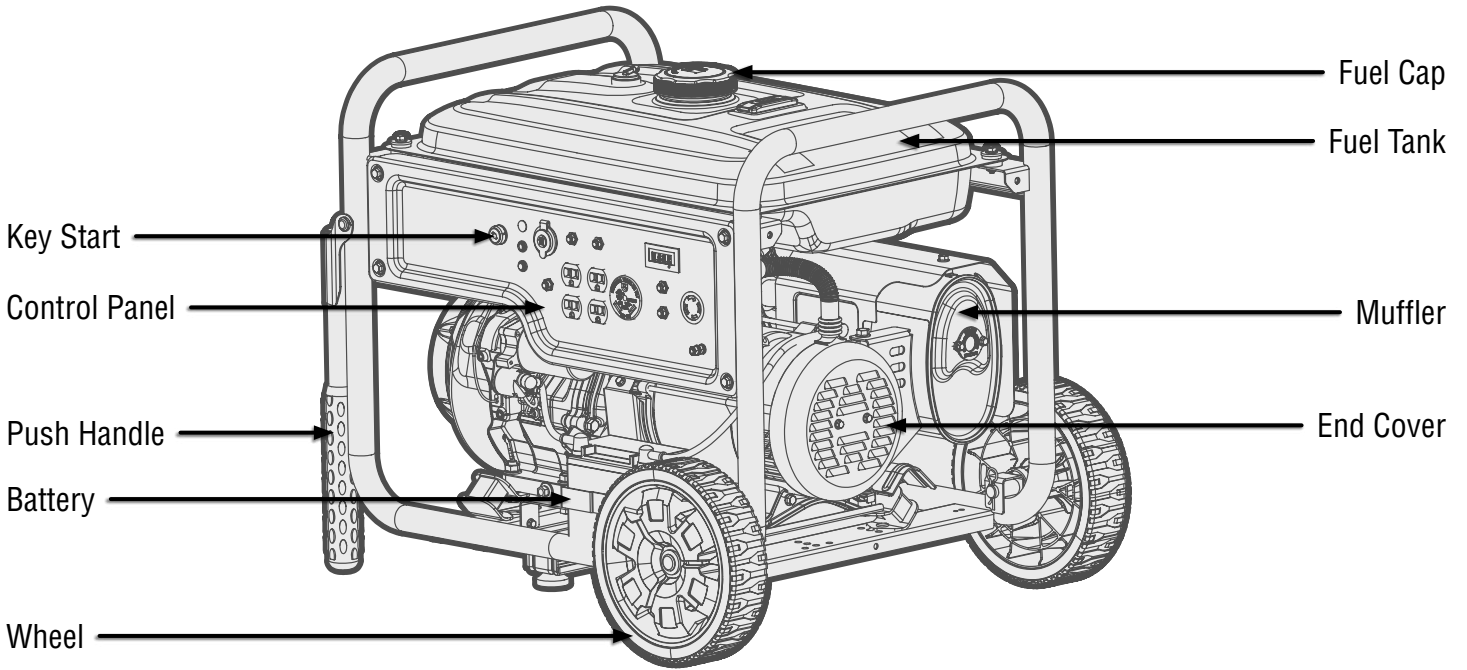

# KNOW YOUR GENERATOR

## CONTROL PANEL

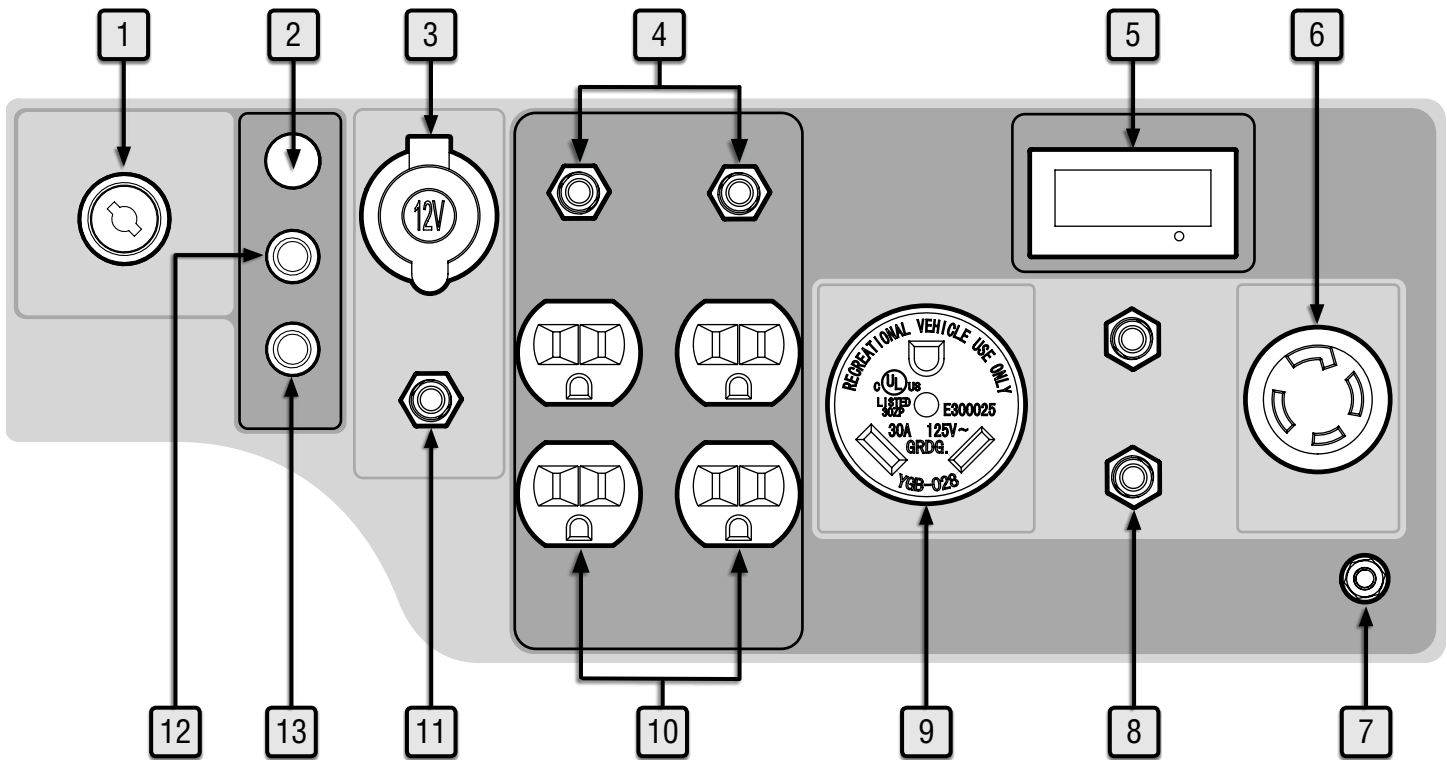

### 1. Key Start

ON, OFF, START

### 2. Pairing Light

Indicates pairing of the remote to your generator. See "USING THE REMOTE START FUNCTION" on page 20.

### 3. 12V DC Outlet

### 4. 5-20R Duplex Circuit Breakers (20A)

### 5. Multi-meter

Displays voltage, frequency, total runtime (HHHH), and session runtime (HH:MM). Press the MODE button to switch between displays.

### 6. AC 120V/240V NEMA L14-30R Outlet

### 7. Grounding Nut

Ground generator to reduce risk of electric shock.

### 8. AC Circuit Breaker (30A)

### 9. AC 120V NEMA TT-30R RV Outlet

### 10. AC 120V NEMA 5-20V Duplex Outlet

### 11. DC Circuit Breaker (10A)

### 12. Remote Pairing Button

Press to pair the remote to your generator. See "USING REMOTE-START FUNCTION" on page 20.

### 13. Remote Power Button

Press to reset remote pairing. See "USING REMOTE-START FUNCTION" on page 20.

# ASSEMBLY & ADJUSTMENTS

**⚠ WARNING!** Do not plug in or turn on the tool until it is fully assembled according to the instructions. Read through and become familiarized with the following procedures of handling and adjusting your tool. Failure to follow the safety instructions may result in serious personal injury.

## INSTALLING THE WHEELS

1. Prepare a set of blocks on level ground (a 4x4 block of wood works well). Place the generator on the blocks.
2. Place the wheel axle pin (Fig. 1 - 1) and washer (Fig. 1 - 2) through the wheel (Fig. 1 - 3) and mounting lug hole (Fig. 1 - 4). Secure it with the R-clip (Fig. 1 - 5).

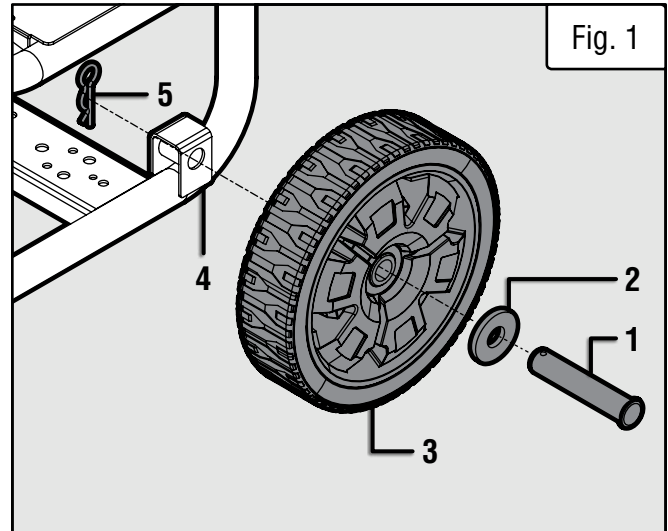

## INSTALLING THE SUPPORT BRACKET

1. Line up the support bracket with the corresponding holes on the bottom of the generator.
2. Secure the support bracket (Fig. 2 - 1) to the generator using two M8x16 bolts (Fig. 2 - 2) and two M8 nuts (Fig. 2 - 3).

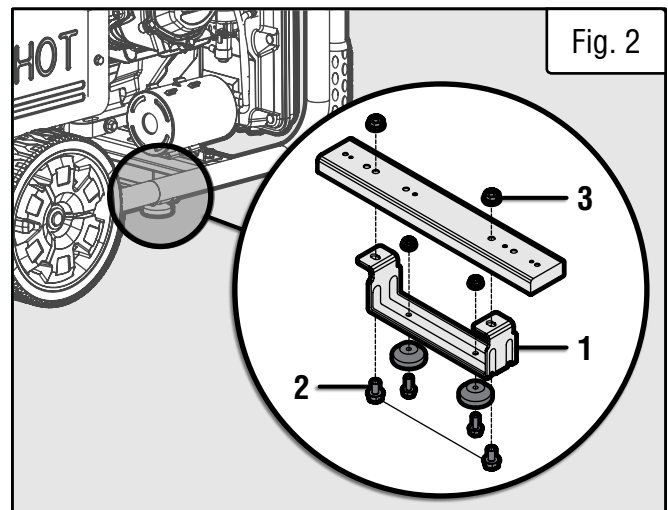

## INSTALLING THE HANDLES

1. Place the handle pin (Fig. 3 - 1) through the handle (Fig. 3 - 2) and the generator frame (Fig. 3 - 3). Secure it with the R-clip (Fig. 3 - 4).

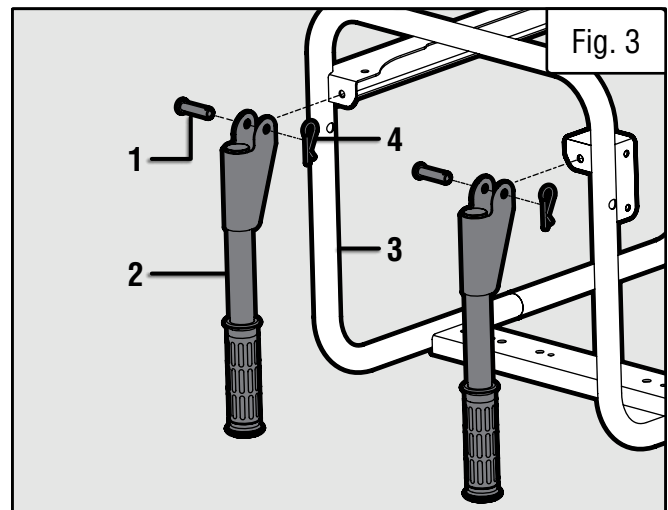

**After completing the above assembly, the generator is ready for preparation.**

# GENERATOR PREPARATION

The following section describes the necessary steps to prepare the generator for use. If you are unsure about how to perform any of the steps, please call **1-(800) 232-1195** M-F 8-5 CST for customer service. Failure to perform these steps properly can damage the generator or shorten its life.

## STEP 1 - ADD / CHECK OIL

The generator is shipped without oil. User must add the proper amount of oil before operating the generator for the first time. The oil capacity of the engine crankcase is 37.2 fl. oz. (1.1 L).

### ENGINE OIL RECOMMENDATIONS

Select good quality detergent oil bearing the American Petroleum Institute (API) service classifications SJ, SL, or SM (synthetic oils may be used). Select the SAE viscosity grade of oil that matches the expected operating temperature.

Fig. 4

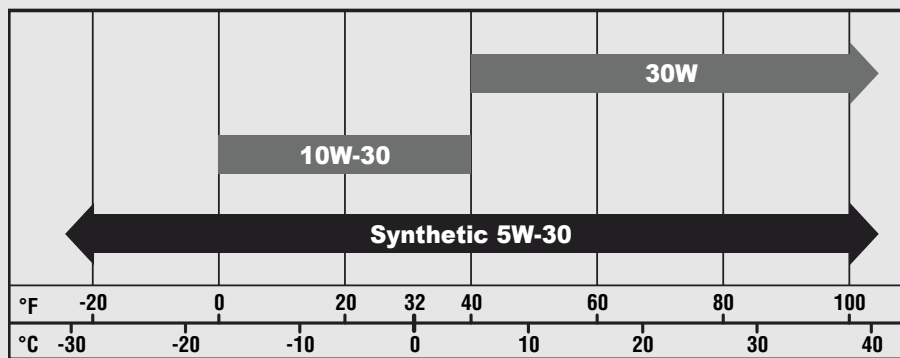

- **30W Engine Oil**  
Temperatures above 40°F
- **10W-30 Engine Oil**  
Temperatures between 0°F - 40°F
- **Synthetic 5W-30 Engine Oil**  
All temperature ranges

### To add oil, follow these steps:

1. Place the generator on a level surface. Make sure the engine is off before adding or checking oil.

**CAUTION!** Keep the generator level! Tilting the generator to assist in filling will cause oil to flow into the wrong areas of the engine and cause damage.

2. Unscrew the oil dipstick (Fig. 5 - 1) from the engine.

3. Using an oil funnel or appropriate dispenser, slowly add oil into the oil fill, being careful not to overfill the unit. Fill the crankcase to the upper fill line so you can visually see the oil coming halfway up the oil fill threads.

4. Reinstall the oil dipstick and firmly tighten it. Wipe clean any spilled oil.

**CAUTION!** For subsequent operation, the oil level should be checked before each use, or after every 8 hours of operation. The generator is equipped with a low-oil sensor and will not start without a sufficient amount of oil.

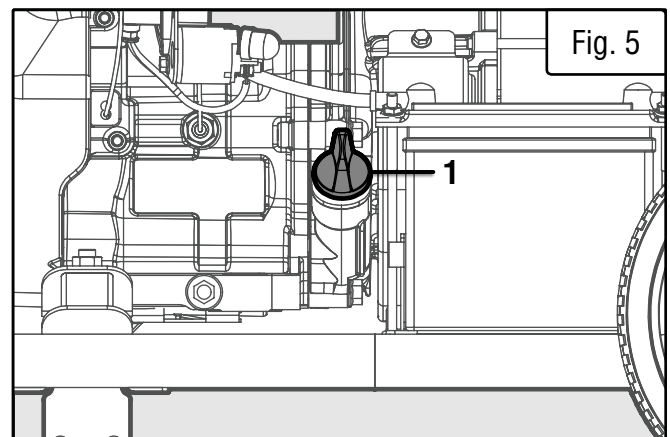

Fig. 5

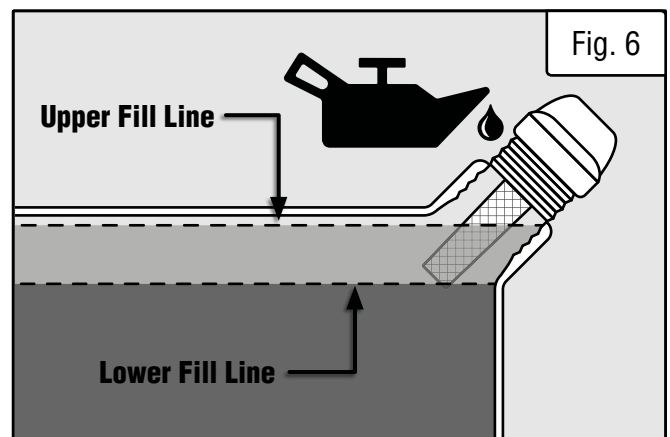

Fig. 6

# GENERATOR PREPARATION

## STEP 1 - ADD / CHECK OIL (CONTINUED)

For subsequent operation, the oil level should be checked before each use, or after every 8 hours of operation. The generator is equipped with a low-oil sensor and will not start without a sufficient amount of oil.

### To check oil level (before every subsequent start):

1. Place the generator on a level surface. Make sure the engine is OFF before adding or checking oil.
2. Remove and wipe the dipstick with a clean rag.
3. Insert the dipstick into the oil fill without screwing it in. Remove the dipstick to check the oil mark.
4. If the oil mark covers **less than one half** of the dipstick, slowly **add oil** until the oil mark reaches the top of the dipstick (or when you can see the oil coming halfway up the oil fill threads).

## OIL LEVEL SHUTDOWN

To protect the unit from damage, the generator is equipped with a low-oil-pressure shutoff that will automatically shut down the engine when the oil level is too low. The oil level of the engine should be checked before each start to ensure that the engine crankcase contains sufficient lubricant.

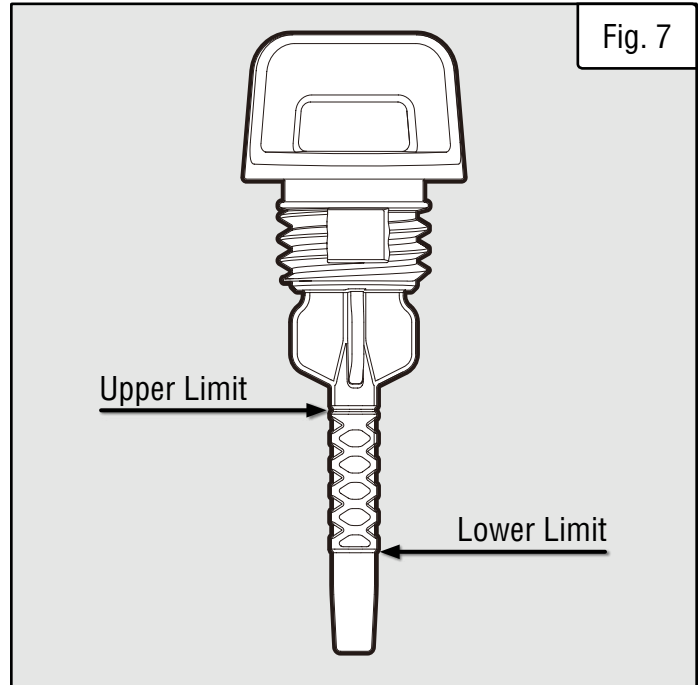

# GENERATOR PREPARATION

## STEP 2 - ADD / CHECK FUEL

**⚠ WARNING! RISK OF EXPLOSION. HIGHLY FLAMMABLE:** This generator may emit highly flammable and explosive gasoline vapors, which can cause severe burns or even death, if ignited. A nearby open flame can lead to explosion even if not directly in contact with gasoline.

- Do not operate near open flame, heat, or any other ignition source. Do not smoke near the generator.
- Always operate on a firm, level surface.
- Always turn generator off before refueling. Allow generator to cool for at least 2 minutes before removing fuel cap. Loosen cap slowly to relieve pressure in tank.
- Do not overfill fuel tank. Gasoline may expand during operation. Do not fill to the top of the tank. Allow for expansion. Always check for spilled fuel before operating.
- If fuel spills, move the generator at least 30 feet away from the spill and wipe clean any spilled fuel before starting the engine.
- Empty fuel tank before storing or transporting the generator.

Use **ONLY** fresh (within 30 days from purchase), lead-free gasoline with a minimum of 87 octane rating. The generator performs best with ethanol-free gasoline. **DO NOT** use gasoline with over 10% ethanol. The capacity of the fuel tank is 6 US gallons (23 L). Do not mix oil with gasoline.

### To add gasoline:

1. Place the generator on a level surface. Make sure the engine is OFF before adding or checking the fuel.
2. Unscrew the fuel cap (Fig. 8 - 1) and set it aside. The fuel cap may be tight and hard to unscrew.
3. Slowly add unleaded gasoline to the fuel tank. Be careful not to overfill. Reinstall fuel cap and wipe clean any spilled gasoline with a dry cloth.

**NOTE:** Do not fill the fuel tank to the very top. If you do so, gasoline will expand and spill during use, even with the fuel cap in place.

4. Reinstall fuel cap and wipe clean any spilled gasoline with a dry cloth.

### To check fuel level:

1. Before starting the generator, check the fuel gauge to see if there is sufficient fuel inside the tank:

- E = Empty
- F = Full

2. If the tank is empty add gasoline to the gas tank. See above section, "To Add Gasoline".

### IMPORTANT:

- Avoid getting dirt or water into the fuel tank.
- Keep gasoline away from sparks, open flames, pilot lights, heat, and other sources of ignition.
- Gasoline can age in the tank and make starting difficult. Never store the generator for more than 2 months with fuel in the tank.
- Never use an oil/gasoline mixture.
- Never use old gasoline.

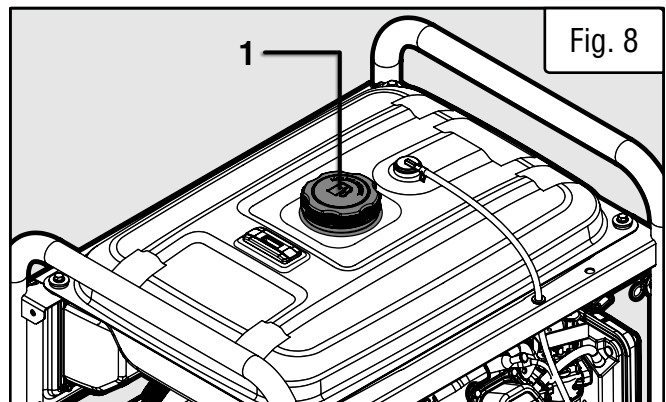

# GENERATOR PREPARATION

## STEP 3: CONNECT THE BATTERY

**⚠ WARNING!** Battery gives off explosive hydrogen gas.

- Keep battery away from spark, flame, or cigarette.
- Do not connect or disconnect battery while generator is running.
- Service or use battery only in well ventilated areas.

**⚠ WARNING!** Battery contains sulfuric acid. Battery acid is poisonous. Tilting the generator with the battery installed can cause battery acid to spill.

- Wear protective clothing and eye wear when servicing battery.
- Keep out of reach of children.
- Do not tilt generator with battery installed.
- If battery acid gets on your skin, wash with water immediately.
- If battery acid gets in your eyes, flush with water for at least 15 minutes and call a doctor immediately.

If battery acid is swallowed, call a doctor immediately. Drink a large amount of water or milk. Then drink milk of magnesia or vegetable oil.

The generator comes with battery disconnected for safety. The battery must be connected for electric start, but does not need to be connected for recoil start. If the battery is connected, it will receive charge while the engine is running.

### To connect the battery (Fig. 9):

1. Remove the red cover from the positive (+) battery terminal.
2. Connect the red cable to the positive (+) battery terminal with the suitable nuts and bolts.
3. Make sure connections are secure and slide rubber boot over the positive (+) battery terminal and connection hardware.
4. Connect the black cable to the negative (-) battery terminal with the suitable nuts and bolts.
5. Make sure all connections are secure and slide rubber boot over the negative (-) battery terminal and connection hardware.

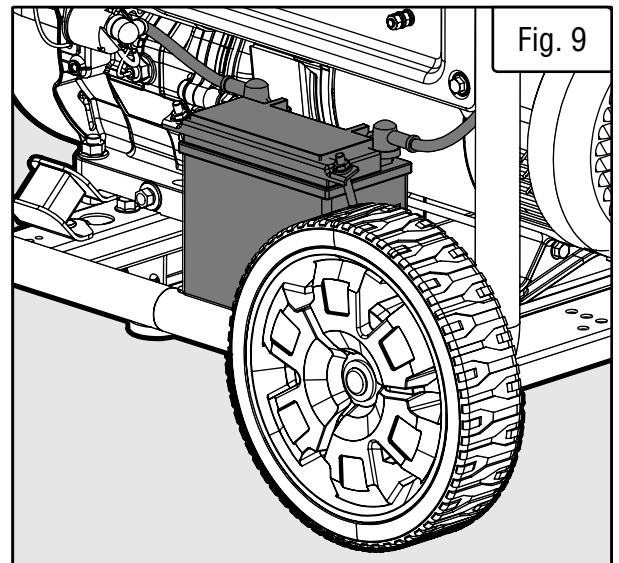

**IMPORTANT:** If you do not plan to use the generator for an extended period of time, it is recommended to disconnect the negative battery cable from the battery to protect the battery from losing charge. After disconnecting the cable, cover the free end with an insulator such as electrical tape.



# GENERATOR PREPARATION

## STEP 4 - GROUND THE GENERATOR

To reduce the risk of electric shock and to maximize safety, the generator should be properly grounded.

Ground generator by tightening grounding nut (Fig. 10 - 1) on the front control panel against a grounding wire. A generally acceptable grounding wire is a No. 12 AWG (American Wire Gauge) stranded copper wire.

This grounding wire should be connected at the other end to a copper, brass, or steel grounding rod that is driven into the earth. Wire and grounding rods are not included with the generator.

**NOTE:** Grounding codes can vary by location. Contact a local electrician to check the area codes.

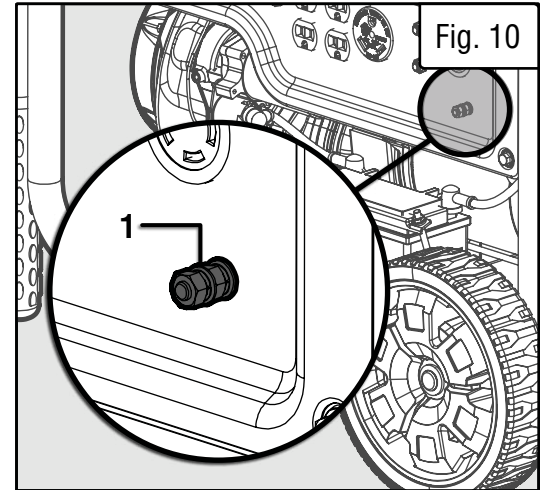

**⚠ WARNING!** Failure to properly ground the generator increases your risk of electric shock.

## HIGH ALTITUDE OPERATION ABOVE 3000 FEET

The fuel system on this generator may be affected by operation at high altitudes. Proper operation can be ensured by installing an altitude kit at altitudes higher than 2000 feet above sea level. At elevations above 7000 feet, the engine may experience a decrease in performance, even with the proper altitude kit. Operating this generator without said kit may increase the engine's emissions and decrease both fuel economy and performance.

You can order the kit at [wenproducts.com](http://wenproducts.com) by searching part GN9500-HA36 or GN9500-HA68. There are two kits - one for altitudes between 3000 and 6000 feet (GN9500-HA36), and the other for altitudes from 6000 to 8000 feet (GN9500-HA68). This kit should be installed by a qualified mechanic. Refer to the instructions included with your altitude kit for more information about installation.

**⚠ WARNING!** To prevent serious injury from fire, follow the kit installation procedures in a well-ventilated area away from ignition sources. If the engine is hot from use, shut the engine off and wait for it to cool before proceeding. Do not smoke near the generator. Warranty will be void if adjustments are not made for high altitude use.

**CAUTION:** Engines with the high-altitude kit installed operated at lower altitudes could cause severe engine damage and affect emissions compliance. Be sure to uninstall the high altitude kit when operating at altitudes below 2000 feet.

**After completing the above preparation, the generator is ready to be started.**

## STARTING YOUR GENERATOR

Before starting the generator, make sure you have read and performed the steps in the “Generator Preparation” section of this manual. If you are unsure about how to perform any of the steps in this manual please call **1-(800) 232-1195** M-F 8-5 CST for customer service.

### **DANGER! CARBON MONOXIDE**

Using a generator indoors **CAN KILL YOU IN MINUTES**. Generator exhaust contains carbon monoxide (CO). This is a poison gas you cannot see or smell. If you can smell the generator exhaust, you are breathing CO. But even if you cannot smell the exhaust, you could be breathing CO.

**NEVER** use a generator inside homes, garages, crawl spaces, or other partially enclosed areas. Deadly levels of carbon monoxide can build up in these areas. Using a fan or opening windows and doors does NOT supply enough fresh air. **ONLY** use a generator outside and far away from windows, doors, and vents. These openings can pull in generator exhaust.

Even if you use a generator correctly, CO may leak into the home. **ALWAYS** use a battery-powered or battery-backup CO alarm in the home. If you start to feel sick, dizzy, or weak after the generator has been running, move to fresh air **RIGHT AWAY**. See a doctor. You may have carbon monoxide poisoning.

 **WARNING!** The exhaust from this product contains chemicals known to the State of California to cause cancer, birth defects, or other reproductive harm.

 **WARNING!** Do not operate generator near open flame or flammable materials. This generator may emit highly flammable and explosive gasoline vapors, which can cause severe burns or even death if ignited. A nearby open flame can lead to explosion even if it isn't directly in contact with gasoline. Do not smoke near the generator.

 **WARNING!** This generator produces powerful voltage, which can result in electrocution.

 **WARNING!** Do not use in rainy or wet conditions. Do not touch bare wires or receptacles (outlets). Do not allow children or non-qualified persons to operate.

 **WARNING!** Generator should only be connected to electrical devices, either directly or with an extension cord. **NEVER** connect to a building electrical system without a qualified electrician and connected to a transfer switch as a separately derived system. Such connections must comply with local electrical laws and codes. Failure to comply can create a back-feed, which may result in serious injury or death to utility workers.

To maximize safety, **ALWAYS** ground the generator before using it. See section “Ground the Generator”.

Use a ground fault circuit interrupter (GFCI) in highly conductive areas such as metal decking or steel work. GFCIs are available in-line with some extension cords.

**CAUTION!** Disconnect all electrical loads from the generator before attempting to start.

**Follow the instructions on the next page to start your generator.**

# STARTING YOUR GENERATOR

## BEFORE STARTING THE GENERATOR

1. Verify that generator is outside on a dry, level surface with at least two feet of clearance on all sides.
2. To maximize safety, check that the generator is properly grounded (see "Ground the Generator").
3. Check there is sufficient level of oil in the crankcase. Add oil if necessary (see "Add / Check Oil").
4. Make sure there is sufficient level of gasoline in the fuel tank. Add fuel if necessary (see "Add / Check Fuel").
5. Make sure all electrical devices are unplugged from the generator during ignition. Otherwise it will be difficult for the engine to start.

## STARTING THE GENERATOR

1. Turn the fuel valve (Fig. 11) to the ON position.
2. Move choke lever (Fig. 12) to the CLOSE / START position.

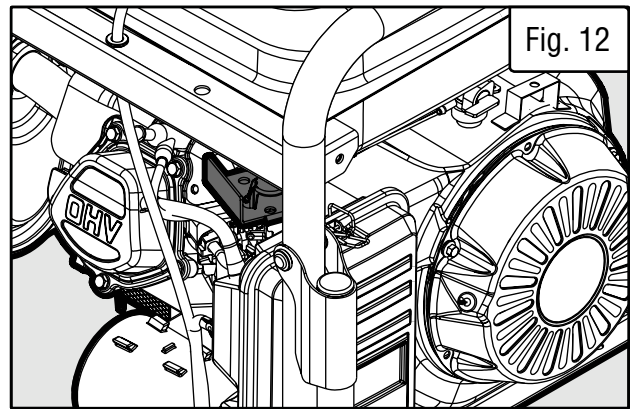
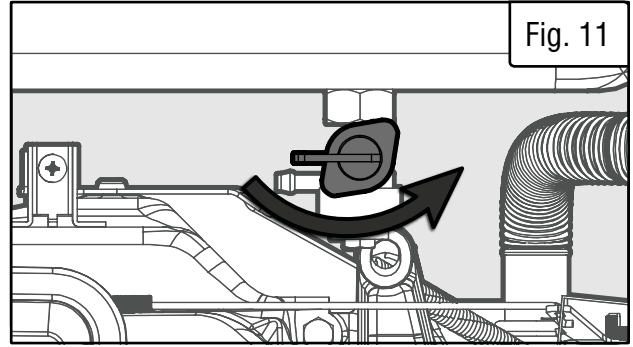

### a. To start the engine with electric starter:

3. Insert the key and turn the engine switch to the START position for 2-3 seconds.

**NOTE:** If the engine does not start, release the switch and try again. Keeping the switch in the START position too long can damage the starter.

4. When engine starts, release the switch to ON.
5. Slowly move choke lever to the OPEN/RUN position. If engine fires, but does not continue to run, move choke lever to CLOSE / START position and repeat starting instructions.

**NOTE:** If the engine is warm place the choke lever on OPEN / RUN

**To start your generator using remote start, see the next page.**

### b. To start the engine with recoil starter:

3. Turn the engine switch to the ON position.
  4. Pull on the recoil starter handle slowly until a slight resistance is felt, then pull quickly to start the engine. Return cord gently into the recoil starter. Never allow the cord to snap back.
- If engine fails to start, repeat this step.
5. Once the engine has started, slowly return the choke lever all the way to the OPEN / RUN position.

6. Allow the engine to run for several minutes before attempting to connect any electrical devices. This allows the generator to stabilize its speed and temperature. Follow the instructions in the "Using Your Generator" section for properly connecting your electrical devices.

**NOTE:** In case you have had repeated failed attempts to start the engine, please consult the troubleshooting guide before attempting to start the generator. If problems persist please call **1-(800) 232-1195**, M-F 8-5 CST.

# STARTING YOUR GENERATOR

## USING THE REMOTE-START FUNCTION

Your generator comes with a remote-start function, enabling you to (what else?) start your generator remotely.

Your generator and the included remote have been paired at the factory, and you can use the remote immediately.

**NOTE:** in order for the remote start function to work properly, you must be within 164 ft (50 m) of the generator. The remote's effective range may vary depending on the batteries' state of charge, as well as miscellaneous environmental factors, radio interference, etc.

## STARTING THE GENERATOR (REMOTE START)

1. Insert the engine switch key and turn the engine switch on the control panel (Fig. 13 - 1) to ON. Ensure that the battery is connected.
2. Ensure that all electrical devices are disconnected from the generator.
3. Press the REMOTE POWER button (Fig. 13 - 3) on the control panel.
4. Press START button (Fig. 14 – 1) on remote control once. DO NOT hold button down. The generator will automatically adjust the choke and start.
5. Generator will automatically delay providing power to panel for about 15 seconds. For more about this feature, see “Panel Protection” below.

## STOPPING THE GENERATOR (REMOTE START)

1. Turn OFF and disconnect electrical devices.
2. Press the STOP button (Fig. 14 – 2) on the remote control once. DO NOT hold the button down. The generator will immediately cut off power to the panel, then shut down the engine about 5 seconds later. For more about this feature, see “Panel Protection” below.

**NOTE:** during remote start and remote stop, you may see the data meter display flicker slightly. This is normal and does not indicate a problem.

**NOTE:** If you purchase a new remote, you will need to pair the new remote with the generator. Follow instructions below. When replacing batteries in a remote, you should not need to pair the generator and remote again, but if you find that it does not work with new batteries, follow the instructions below to pair the generator and remote again.

## PAIRING THE REMOTE AND GENERATOR

1. Insert the engine switch key and turn the engine switch on the control panel (Fig. 13 - 1) to ON.
2. Press the REMOTE POWER button (Fig. 13 - 3) on the control panel.
3. Press and hold REMOTE PAIRING button (Fig. 13 - 2) on control panel until PAIRING LIGHT (Fig. 13 – 4) turns on.
4. Press the START button (Fig. 14 – 1) on the remote control once. The PAIRING LIGHT will turn off, then back on.
5. Press and hold REMOTE PAIRING button on control panel until PAIRING LIGHT turns off (about 2 seconds). The generator and remote are now paired.

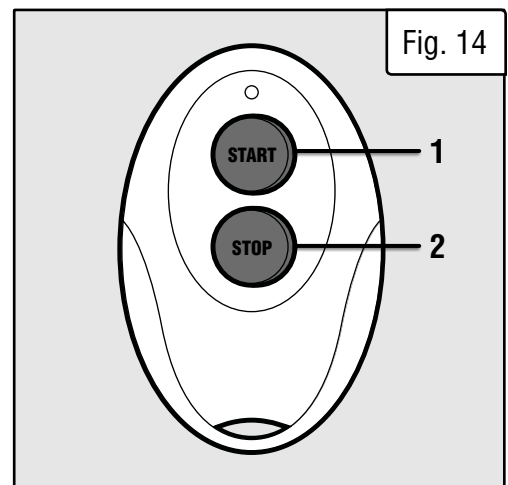
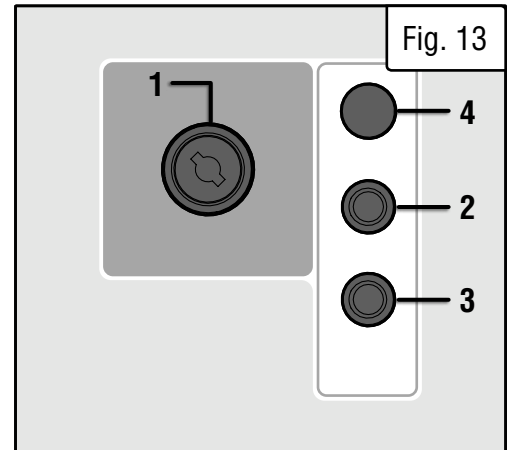

# STARTING YOUR GENERATOR

## UNPAIRING THE REMOTE AND GENERATOR

1. Insert the engine switch key and turn the engine switch on the control panel (Fig. 13 - 1) to ON.
2. Press the REMOTE POWER button (Fig. 13 - 3) on the control panel.
3. Press and hold REMOTE PAIRING button (Fig. 13 - 2) on control panel until PAIRING LIGHT (Fig. 13 - 4) turns on.
4. Press the STOP button (Fig. 14 - 2) on the remote control once. The PAIRING LIGHT will turn off, then back on.
5. Press and hold the REMOTE PAIRING button on the control panel until the PAIRING LIGHT turns off (about 2 seconds). The generator and remote are now unpaired.

## REPLACING REMOTE BATTERIES

1. Use a screwdriver to loosen the 2 screws on back of remote. Open the back of the remote and remove the 2 CR2016 batteries from the battery compartment.
2. Install 2 new CR2016 batteries in battery compartment, in the same orientation as you removed the old batteries.
3. Replace the back of the remote and tighten the screws. Follow the instructions above to pair your remote with the generator.

## STANDBY MODE

Once the generator is shut down, the generator's remote control function will stay in standby mode for 12 hours while the engine switch is ON. If the engine is not started in those 12 hours, the generator will enter sleep mode in order to minimize current draw on the battery and ensure that the generator can be started in times of need. In sleep mode, the generator cannot be started via the remote control, but it can be started using the keyed electric start or recoil start.

When the generator is in sleep mode, press REMOTE POWER button on the control panel to put the generator in standby mode. In standby mode, the generator can be started using the remote.

## PANEL PROTECTION

As mentioned above, the generator automatically disconnects power to the control panel when starting and stopping using remote start. This is to protect the loads that are connected to the generator from being damaged by non-60Hz power. The power delay only happens when the remote is used to start or stop the generator, and will not happen if another method is used to start or stop the generator. ALWAYS make sure loads are turned off and disconnected from the generator when starting or stopping the generator.

## PAIRING MULTIPLE REMOTES

You can pair up to 2 remotes at a time with your generator. Remotes (part no. GN9500-303.2) can be purchased from [wenproducts.com](http://www.wenproducts.com). To pair a new remote with your generator, follow instructions above in "Pairing the Remote and the Generator".

**NOTE:** If you have multiple remotes paired with your generator and you unpair one remote, you will also unpair the other remote simultaneously. You will need to pair the other remote with the generator again before it can be used.

If at any point you have questions, problems, or concerns about the remote start function, consult the Troubleshooting guide on p. 34 or contact customer service at **1-800-232-1195**.

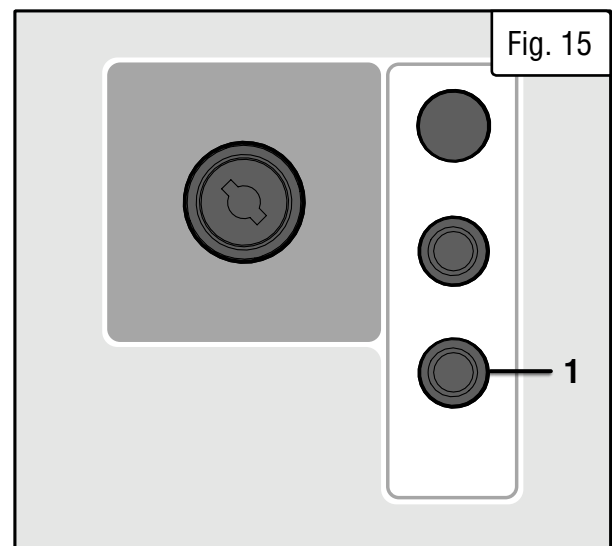

# USING YOUR GENERATOR

## CALCULATING THE WATTAGE OF YOUR DEVICE(S)

Connect electrical devices running on AC current according to their wattage requirements. Calculate the total running wattage and starting wattage of the device(s) you wish to connect, and **MAKE SURE** that they are within the capacity of your generator and the capacity of each individual outlet.

Generator Wattage Capacity	GENERATOR RUNNING (RATED) WATTS	GENERATOR STARTING (SURGE) WATTS
		<b>7500W</b>
	<p><b>What this means:</b> The generator can produce a maximum of 7500W on a continuous basis to supply on-going power to your electronic devices.</p> <p><b>NOTE:</b> Also check the rated amperage for each outlet and make sure not to overload the individual outlets.</p>	<p><b>What this means:</b> Some devices such as box fans require short bursts of extra power in addition to the rated wattage listed by the device to start their motors.</p> <p>The generator can produce a maximum wattage of 9500W for a short period of time (seconds) to cover the extra starting power required by your electronic devices.</p>
Electronic Device Wattage Calculation	<p>Find the wattage information of each device you plan to connect. The information should be listed on the device or in its instruction manual, or you may refer to page 23, Table 2.</p> <p style="text-align: center;">The wattage can be calculated using this equation: <b>Watts = Volts x Amperes</b></p>	
	<p><b>To calculate the total running watts of your devices:</b></p> <p>+ Add up the running wattages of all the device(s) you plan to connect.</p> <p>= The total running (rated) wattage.</p> <p>This wattage should NOT exceed the running wattage of <b>7500W</b>.</p> <p>It is recommended to maintain a load at or below 6300W (90% of the rated output) to ensure steady voltage output and to prolong the generator's lifespan.</p>	<p><b>To calculate the total starting watts of your devices:</b></p> <p>+ Add up the total running wattage of all the device(s) you plan to connect.</p> <p>+ Add the single highest <b>ADDITIONAL</b> starting wattage out of the device(s) you plan to connect.</p> <p>= The total starting (surge) wattage.</p> <p>This wattage should NOT exceed the starting wattage of 9500W.</p>
	<p>If any of either of the total calculated running watts or starting watts is higher than the capacity of your generator, adjust the load until both wattage requirements are met. Otherwise you will overload the generator, and cause damage to the engine and your electrical device(s).</p>	

Table 1 - How to Calculated Wattages

# USING YOUR GENERATOR

## CALCULATING THE WATTAGE OF YOUR DEVICE(S) - CONTINUED

The chart below serves as a reference for the estimated wattage requirements of common electrical devices. However, do not solely rely on this chart - all electronics and appliances are built differently. Always check the wattage listed on the electrical device before consulting this chart.

Tool or Appliance	Rated (Running) Watts	Surge (Starting) Watts
Electric Water Heater (40 Gal)	4000	0
Hot Plate	2500	0
Saw - Radial Arm	2000	2000
Electric Stove (Each Element)	1500-2800	0
Saw - Circular	1500	1500
Air Compressor (1 HP)	1500	3000
Window Air Conditioner	1200	1800
Saw - Miter	1200	1200
Microwave	1000	0
Well Water Pump	1000	1000
Sump Pump	800	1200
Refrigerator Freezer	800	1200
Furnace Blower	800	1300
Computer	800	0
Electric Drill	600	900
Television	500	0
Deep Freezer	500	500
Garage Door Opener	480	0
Stereo	400	0
Box Fan	300	600
Clock Radio	300	0
Security System	180	0
Dvd Player / VCR	100	0
Common Light Bulb	75	0

Table 2 - Estimated Wattages of Common Electrical Appliances

**NOTE:** Become familiar with the functions and capacity of each component on the control panel before connecting electrical devices. See page 24 for more information about the components of the control panel. Do not overload generator or individual panel receptacles. Do not connect 50Hz or 3-phase loads to the generator.

# USING YOUR GENERATOR

## CONNECTING ELECTRICAL DEVICES

**⚠ CAUTION!** Become familiar with the functions and capacity of each component on the control panel before connecting electrical devices. Do not overload generator or individual panel receptacles. Do not connect 50Hz or 3-phase loads to the generator.

**Follow the steps below to properly connect your device(s) to the generator:**

1. Before connecting electrical devices, allow the generator to run for a few minutes to stabilize the speed and voltage output.
2. Select the device with the highest wattage, and make sure it is turned off. Plug the device into the matching generator outlet and then turn the device on. Allow the engine to stabilize.
3. Repeat step 2 to plug in each additional device. Do not attempt to plug in or start multiple devices at the same time.

## IN CASE OF OVERLOAD

If your generator becomes overloaded from too much drawn wattage, the push-to-reset circuit breaker(s) on your control panel will activate and cut off the output. When an overload occurs, reduce the load by turning off and unplugging your electronic device(s), then press the activated circuit breaker to reset your generator. If the circuit breaker does not reset, wait several minutes and try again. If no power is produced after resetting, restart your generator.

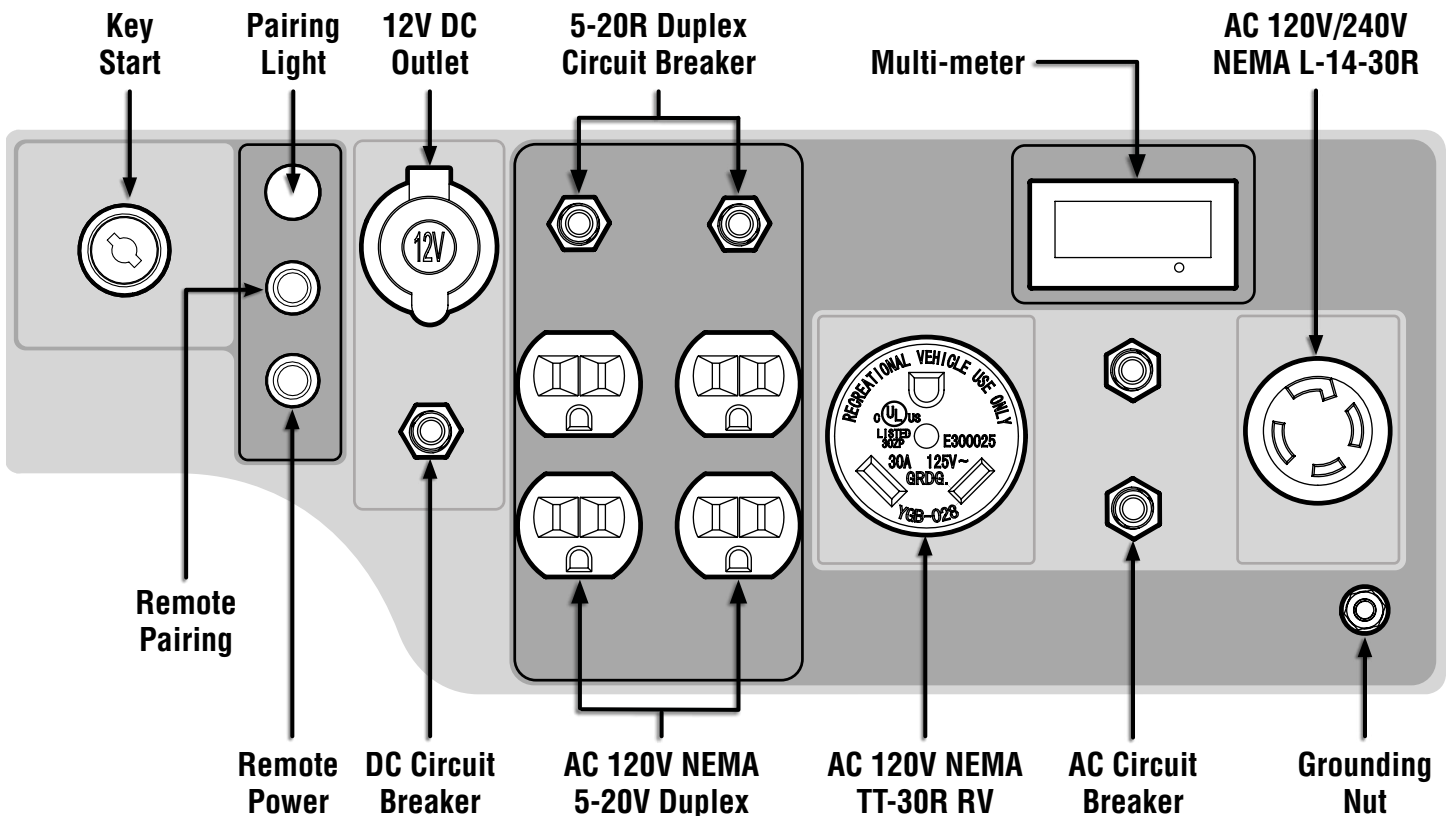



# USING YOUR GENERATOR

## SOME NOTES ABOUT POWER CORDS

Long or thin cords can drain the power provided to an electrical device by the generator. When using such cords, allow for a slightly higher rated wattage requirement by the electrical device.

Device Requirements			Max. Cord Length (ft) by Wire Gauge				
Amps	Watts (120V)	Watts (240V)	#8 wire	#10 wire	#12 wire	#14 wire	#16 wire
2.5	300	600	NR	NR	NR	375	250
5	600	1200	NR	NR	300	200	125
7.5	900	1800	NR	350	200	125	100
10	1200	2400	NR	250	150	100	50
15	1800	3600	NR	150	100	65	NR
20	2400	4800	175	125	75	50	NR
25	3000	6000	150	100	60	NR	NR
30	3600	7200	125	65	NR	NR	NR
40	4800	9600	90	NR	NR	NR	NR

\*NR = Not Recommended

Table 3 - Power Cord Requirement Guide

**⚠ WARNING!** Generator should **only** be connected to electrical devices, either directly or with an extension cord. NEVER CONNECT TO A BUILDING ELECTRICAL SYSTEM without a qualified electrician and connected to a transfer switch as a separately derived system. Such connections must comply with local electrical laws and codes. Failure to comply can create a back-feed, which may result in serious injury or death to utility workers.

**NOTE:** For power outages, permanently installed, stationary generators are better suited for providing backup power to your home. Even a properly connected portable generator can become overloaded. This may result in overheating or stressing the machine's components, possibly leading to generator failure.

# SHUTTING OFF YOUR GENERATOR

**CAUTION!** Unplugging running devices can cause damage to the generator. Never stop the engine with electrical devices connected and running.

**WARNING!** Allow the generator to cool down before touching areas that become hot during use.

**CAUTION:** Allowing gasoline to sit in the fuel tank for long periods of time can make it difficult to start the generator in the future. Never store the generator for extended periods of time (over 2 months) with fuel in the fuel tank. Refer to “Storing the Generator.”

## TO STOP THE GENERATOR

1. Turn off all electrical devices prior to unplugging them from the generator. Unplugging running devices can cause damage to the generator. Never start or stop the generator with electrical devices plugged in or turned on.
2. Let engine run at no-load for several minutes to stabilize internal temperatures of engine and generator.
3. Turn the fuel valve (Fig. 16) to the OFF position. Let the generator run until the fuel is used up.
4. Turn the engine key start (Fig. 17 - 1) to the OFF position.
5. Drain the carburetor. Refer to "Draining The Carburetor" on page 29.

**NOTE:** If for some reason (e.g. refueling, moving the generator, etc.) you need to shut down the generator quickly, simply turn the engine switch to OFF. However, doing this will allow fuel to remain in the carburetor, and will lead to problems if the carburetor is not drained after use.

**CAUTION:** Always ensure that the fuel valve and the engine switch are in the OFF position when the generator is not in use.

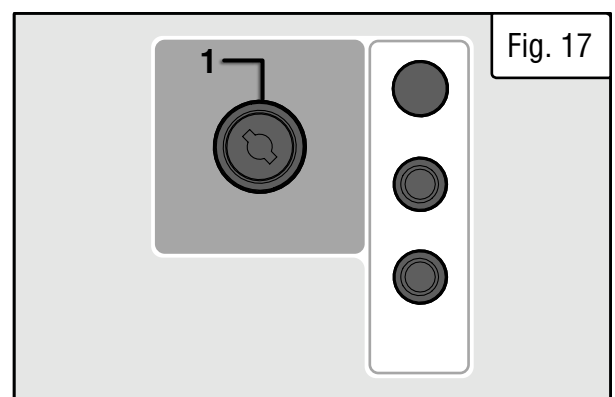
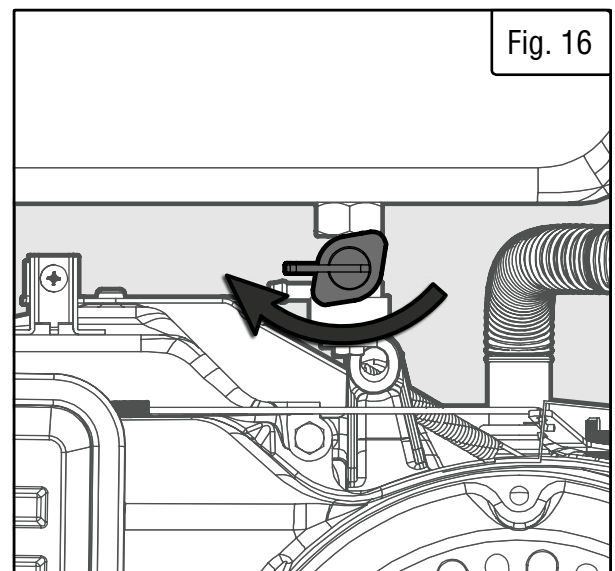

# MAINTENANCE

Proper routine maintenance of the generator will help prolong the life of the machine. Please perform maintenance checks and operations according to the schedule in Table 4.

**⚠ CAUTION!** Never perform maintenance operations while the generator is running. Before maintaining or servicing the generator, turn OFF the generator, disconnect all devices and allow the generator to cool down.

If there are any questions about the maintenance procedures listed in this manual, please call **1-(800) 232-1195** M-F 8-5 CST or email [techsupport@wenproducts.com](mailto:techsupport@wenproducts.com).

Recommended Maintenance Schedule		Every 8 Hours or Daily	Every 25 Hours	Every 3 Months or 50 Hours	Every 6 Months or 100 Hours	Before Storage	As Necessary
Engine Oil	Check Level	x					
	Replace		x*				x
Air Filter	Check			x*			
	Clean			x*			
Spark Plug	Check/Clean/Regap				x		
	Change				x		x
Fuel	Check Level	x					
	Drain					x	x
Carburetor	Drain	x					x
Spark Arrestor	Check/Clean				x		

\* Clean/change more often under dusty conditions or operating under heavy load.

Table 4 - Recommended Maintenance Schedule

### IMPORTANT GENERATOR MAINTENANCE TIPS:

- Drain your carburetor after each use and before storage to prevent it from clogging.
- Do not store the generator with fuel inside the tank for more than 2 months - the fuel will go bad.
- Run the generator for at least 20 minutes every month to charge the battery and maximize lifespan.

### CLEANING THE GENERATOR

Keep the generator clean to prevent improper operation or machine damage from dirt and debris. Inspect all ventilation openings on the generator. These openings must be kept clean and unobstructed. If the generator becomes dirty, use a damp cloth to wipe exterior surfaces. Use a soft bristle brush to loosen dirt and oil and use a vacuum to pick up loose dirt. Use low pressure air (not to exceed 25 PSI) to blow away dirt.

**⚠ CAUTION!** Never clean the generator when it is running! Never clean with a bucket of water or a hose. Water can get inside the working parts of the generator and cause corrosion or a short circuit.

**NOTE:** Failure to properly maintain the generator will void the warranty.

# MAINTENANCE

## CHECKING / ADDING OIL

Check the oil level before each use and every 8 hours of operation (refer to page 27, Table 4). The oil capacity of the generator engine is 37.2 fl. oz. (1.1 L). Add oil when the oil level is low. For the proper type and weight of oil refer to page 13, Fig. 4. This is a critical step for proper engine starting. The generator is equipped with a low-oil shutdown feature to protect it from running without oil. To check the oil level and/or add oil refer to "Step 1 - Add / Check Oil" on page 13.

## DRAINING / CHANGING THE OIL

Change the oil according to the Recommended Maintenance Schedule (refer to page 27, Table 4). Change the oil more often if operating under heavy load or high ambient temperatures. It is also necessary to drain the oil from the crankcase if it has become contaminated with water or dirt. Changing the oil when the engine is warm allows for complete drainage.

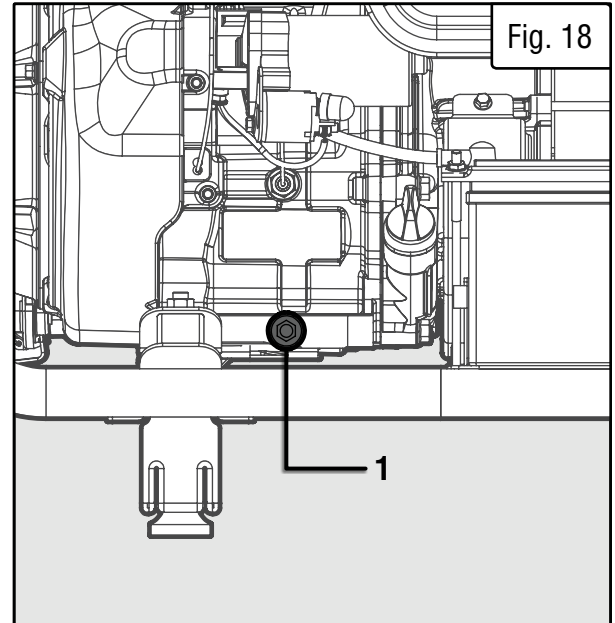

1. Prepare an approved oil-storage container underneath the oil drain bolt next to the oil dipstick to catch the oil as it drains.

**NOTE:** To avoid possible fuel spills from the carburetor bowl, drain the carburetor (refer to "Draining The Carburetor" on page 29) before draining the oil.

2. Unscrew the oil drain bolt (Fig. 18 - 1) and allow oil to drain from the engine completely.

3. Reinstall the oil drain bolt and tighten it securely. Wipe clean any oil spillage.

4. To add new oil, refer to "Step 1 - Add / Check Oil" on page 13.

**NOTE:** Never dispose of used engine oil in the trash or down a drain. Please call a local recycling center or auto garage to arrange proper oil disposal.

# MAINTENANCE

## DRAINING THE CARBURETOR

Drain the carburetor after every use and before storing the generator (refer to page 27, Table 4). Draining the carburetor can help prevent build-up and blockages caused by stagnant fuel inside of the carburetor.

1. Prepare an approved gasoline-storage container under the carburetor to collect drained fuel. Close the fuel valve (Fig. 19).
2. The carburetor can be accessed from the backside of the generator between the engine and air filter. To drain the carburetor, open up the carburetor drain screw (Fig. 20) with a Phillips-head screwdriver and drain out any gasoline that has built up inside.
3. Once the fuel has drained, close the drain screw.

**NOTE:** Make sure to drain your carburetor before storing the generator for long periods of time.

## INSPECTING / CLEANING THE AIR FILTER

Inspect and clean the air filter every 50 hours of operation (refer to page 27, Table 4). Routine maintenance of the air filter helps maintain proper airflow to the carburetor. Occasionally check that the air filter is free of excessive dirt. Clean air filter more frequently in dirty or dusty conditions.

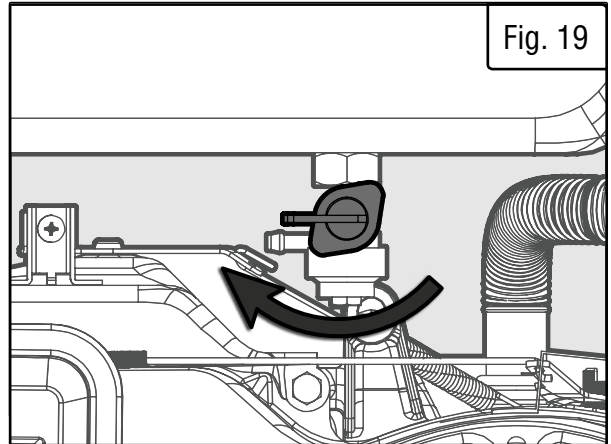

Fig. 19

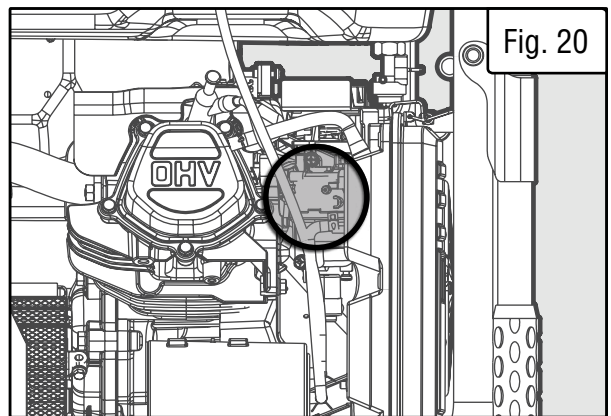

Fig. 20

**⚠ WARNING!** Running the engine with a dirty, damaged or missing air filter element can result in danger to the operator and cause the engine to wear out prematurely.

1. Remove the air filter cover by loosening the clasps at the top and bottom of the air filter cover (Fig. 21 - 1).
2. Remove the foam, sponge-like air filter elements from the casing. Wipe excessive oil and any dirt from inside of the air filter casing.
3. Check the foam, sponge-like air filter elements.
  - a) Good elements can be washed in soapy water. Dry the elements in clean cloth (do not twist it). Add a few drops of engine oil to the air filter elements and spread them evenly. A small amount of oil left in the elements is normal and necessary for the engine to work properly.

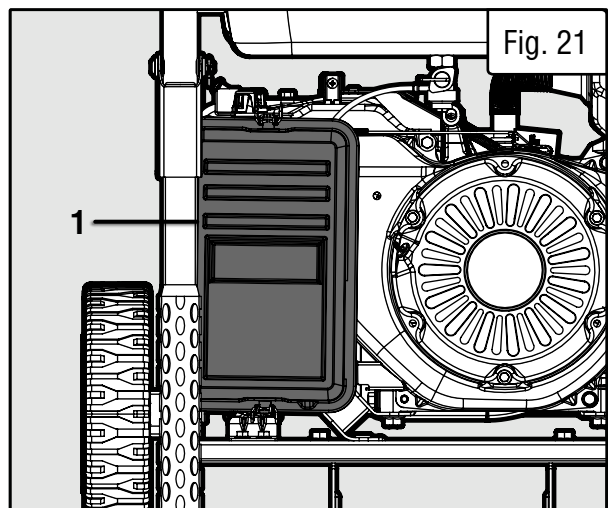

Fig. 21

b) Damaged elements should be replaced with a new one. Replacement air filters can be purchased from [wenproducts.com](http://wenproducts.com) by searching part number GN9500-138.

4. Reinstall the air filter element and air filter elements. The coarse element goes on the inside (toward the carburetor) and the fine element on the outside (toward the air filter cover). Replace the cover.

# MAINTENANCE

## SPARK ARRESTOR MAINTENANCE

Inspect and clean the spark arrestor every 100 hours of operation (refer to page 27, Table 4). The spark arrestor is located outside the muffler, which gets very hot during operation. Allow the engine to cool completely before servicing the spark arrestor.

1. Remove the two Phillips-head screws that secure the spark arrestor to the muffler (Fig. 22).
2. Remove the spark arrestor screen.
3. Carefully clean and remove carbon deposits from the spark arrestor screen with a wire brush. Replace the spark arrestor if it is damaged. Replacement spark arrestors can be purchased from [wenproducts.com](http://wenproducts.com) by searching the part number GN9500-035.1.
4. Reinstall the spark arrestor in the muffler and secure it in place with the screws.

## SPARK PLUG MAINTENANCE

Inspect and change the spark plug every 100 hours of operation (refer to page 27, Table 4). The spark plug is important for proper engine operation. Check the spark plug regularly to maintain proper engine operation. A good spark plug should be intact, free of deposits, and properly gapped.

1. Gently pull on the spark plug boot to remove it. Be careful not to tear insulation or wire.
2. Use included spark plug wrench to unscrew spark plug from the engine. Remove the spark plug from the engine. (Fig. 23)

**TIP:** There is limited space for the wrench to turn. Use both rows of holes in the spark plug wrench to gain leverage to loosen the plug.

3. Visually inspect the spark plug. If it is cracked or chipped, or if the electrodes are worn or burned, discard it and replace with a new spark plug. We recommend replacing it with an NGK BP6ES/Torch F6TC spark plug. These can be purchased from [wenproducts.com](http://wenproducts.com) by searching part number 56500-123.

4. If re-using spark plug, use a wire brush to clean any dirt from around spark plug base, then re-gap spark plug.
5. Measure plug gap with a spark plug gap gauge. Gap should be 0.6 to 0.8 mm. Adjust gap if necessary. (Fig. 24)
6. Screw spark plug back into spark plug hole using spark plug wrench. Do not over-tighten. Recommended tightening of spark plug is  $\frac{1}{2}$  -  $\frac{3}{4}$  of a turn 15 - 20 Nm (11.06 - 14.75 ft-lb) after spark plug gasket contacts spark plug hole.
7. Reinstall the spark plug boot over the spark plug.

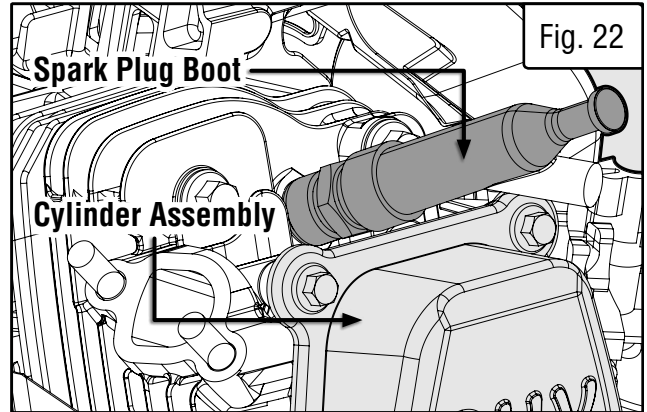

Fig. 22

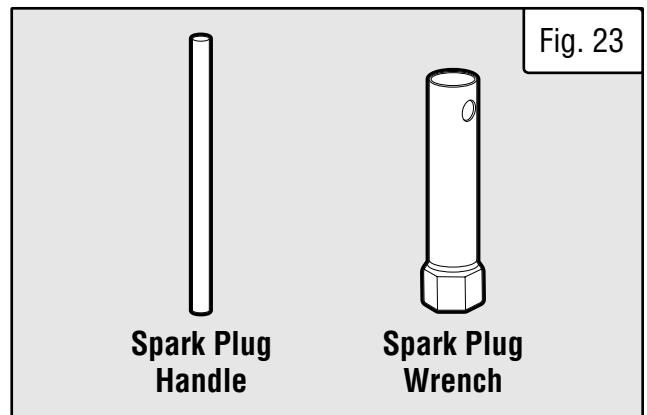

Fig. 23

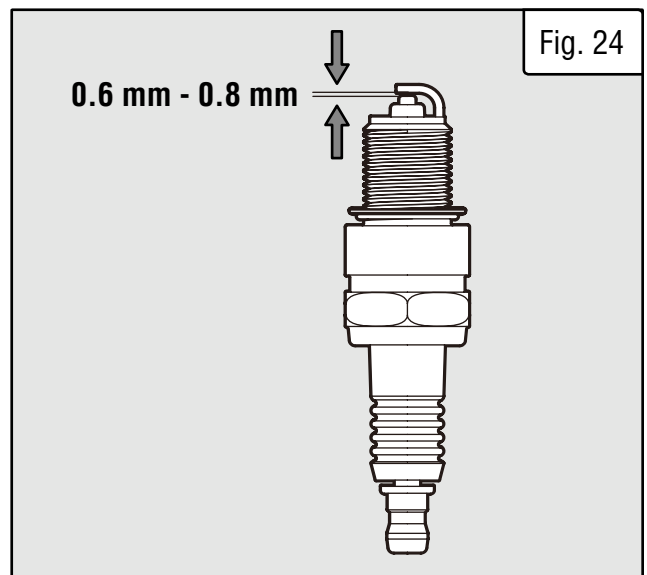

Fig. 24

# MAINTENANCE

## DRAINING THE FUEL TANK

Drain and clean the fuel tank each year, or before storing the generator for longer than two months.

1. Prepare an approved gasoline-storage container to collect the drained fuel. Place it near the fuel valve.
2. Turn the fuel valve (Fig. 25) to the OFF position.
3. Locate the fuel line (Fig. 26 - 1) between the fuel valve and the carburetor. Disconnect the fuel line from the fuel valve.

**NOTE:** A small amount of fuel may leak from the fuel line during removal.

4. Place a funnel below the fuel valve opening, and direct the other end of the funnel over the prepared container.
5. Turn the fuel valve to the ON position to start draining the fuel from the fuel valve opening.

**NOTE:** The draining process may take a few hours, depending on the amount of fuel in your gas tank.

6. Once the fuel is completely drained, turn the fuel valve to the OFF position.
7. Start and run the engine until the fuel runs out.
8. Drain the carburetor. Refer to "Draining The Carburetor" on page 29.

**CAUTION!** Store the emptied gasoline in a suitable place. Never store fuel for more than 2 months.

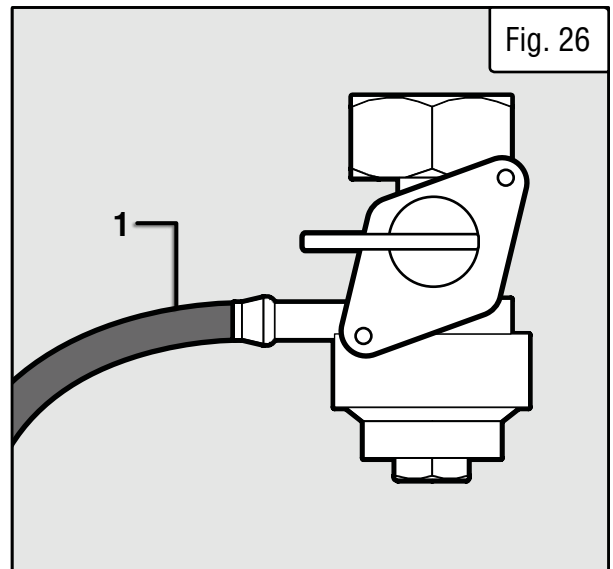
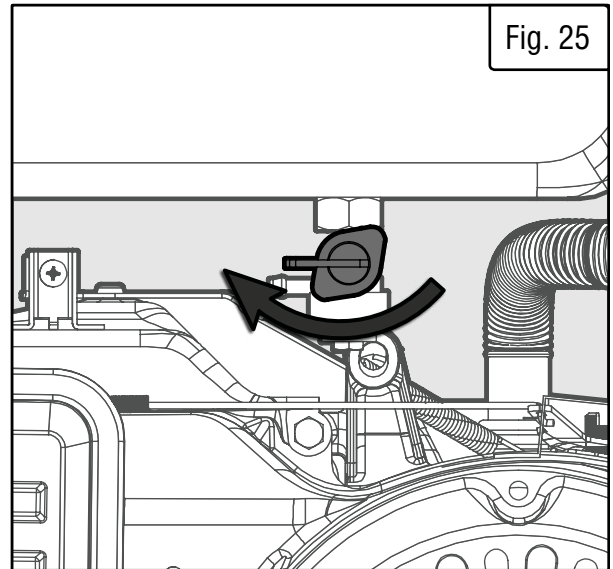

# MAINTENANCE

## BATTERY MAINTENANCE/STORAGE

The battery (part no.GN9500-059) shipped with the generator has been fully charged. The battery will receive charge when the engine is running. Remember to run the generator once a month for 20-30 minutes to charge the battery. A charged battery will allow you to start the generator using the electric start switch during your next time of need.

If the battery is out of charge, you can still manually start the generator using the recoil start.

**IMPORTANT:** If the generator is not used for a long period, it is recommended to disconnect the negative battery cable from the battery to protect the battery from losing charge. After disconnecting the cable, cover the free end with an insulator such as electrical tape. You may also connect the battery to an automatic trickle charger to keep the battery charged.

### To reinstall/replace the battery:

1. Disconnect the negative (-) battery terminal first (black wire).
2. Disconnect the positive (+) battery terminal second (red wire).
3. To install a new battery, install the hold down bracket, insert the threaded rod and tighten with M6 nuts.
4. Connect the positive (+) battery terminal (red wire) first. Slide rubber boot over the connection hardware.
5. Connect the negative (-) battery terminal (black wire) second. Slide rubber boot over connection hardware.

**NOTE:** Always recycle used batteries in accordance with local laws and regulations. Contact your local solid waste collection site or recycling facility to obtain information on local recycling processes.



# TRANSPORTATION & STORAGE

## TRANSPORTING THE GENERATOR

To prevent fuel spillage when transporting, be sure to perform the following:

1. Tighten the fuel cap.
2. Flip the engine switch to the OFF position.
3. Drain the fuel tank if possible. Refer to section, “Draining the Fuel Tank.”
4. Keep the generator upright. Never place the generator on its side or upside down - doing so could damage the internal components of the generator and make it difficult to start.

 **WARNING!** Avoid direct sunlight inside a vehicle. If the generator is left in an enclosed vehicle for many hours, the high temperature could cause the fuel to vaporize and result in a possible explosion.

## STORING THE GENERATOR

Shut off the generator and allow the unit to cool to room temperature before storing it. NEVER place any type of storage cover on the generator while it is still hot. Do not obstruct any ventilation openings.

Follow the procedures below for properly storing your generator. We highly recommend running your generator once a month for 20 to 30 minutes. Plug in a small load in to ensure there is proper power output.

### For Short Periods (30 to 60 Days):

- Drain the carburetor. Refer to page 29, “Draining the Carburetor.”
- Disconnect the negative lead from the battery.
- **Add fuel stabilizer:** Follow the suggested portions and instructions of your preferred stabilizer. Run the engine for 15 to 20 minutes, allowing the fuel stabilizer to mix with the gasoline and circulate through the carburetor, and then top off with fuel. Filling the fuel tank full reduces the amount of air in the tank and helps fight deterioration of fuel.

### For Extended Periods (Over 60 Days):

- Disconnect the negative lead from the battery.
- Drain the fuel tank and carburetor (see “Draining the Fuel Tank”). Never store generator with fuel in the tank for more than two months.
- Change the engine oil (see “CHANGING OIL”).

 **WARNING!** Store the generator upright in a cool and dry location, away from sources of heat, open flames, sparks or pilot lights.

## PRODUCT DISPOSAL

Do not dispose of used generator or parts with your household waste. This product contains electrical or electronic components that should be recycled. Please take this product to your local recycling facility for responsible disposal to minimize its environmental impact.

Do not dispose of used oil or fuel in the trash or down a drain. Please contact your local recycling center or auto garage to arrange proper oil/fuel disposal.



**Please recycle the packaging and electronic components where facilities exist. Please contact your local auto garage or recycling facility to properly dispose of oil/fuel.**

# TROUBLESHOOTING GUIDE

**⚠ WARNING!** Stop using the generator immediately if any of the following problems occur or risk serious personal injury. If you have any questions, please contact customer service at **1-800-232-1195** (M-F 8-5 CST), or email [techsupport@wenproducts.com](mailto:techsupport@wenproducts.com).

PROBLEM	POSSIBLE CAUSE	SOLUTION
<b>Engine will not start.</b>	1. Engine switch is set to OFF.	1. Set engine switch to ON.
	2. Fuel valve is turned to OFF.	2. Turn fuel valve to ON.
	3. Oil is low.	3. Add or replace oil. Refer to "Step 1 - Add / Check Oil" on page 13.
	4. Engine is out of fuel.	4. Add fuel. Refer to "Step 2 - Add / Check Fuel" on page 15.
	5. Engine is filled with contaminated or old fuel.	5. Drain the fuel in the tank and fill with fresh fuel. Refer to "Draining The Fuel Tank" on page 31.
	6. Spark plug is dirty or broken.	6. Clean or replace the spark plug. Refer to "Spark Plug Maintenance" on page 30.
	7. Carburetor is air locked.	7. Shut off the fuel valve. Remove the bolt from the bottom of the carburetor. Take off the carburetor bowl to allow it to reset. Replace carburetor bowl and reinstall the bolt.
	8. Ghost in the generator.	8. Persuade ghost to leave.
<b>Engine runs but there is no electrical output.</b>	1. Circuit breaker has been tripped due to overload.	1. Turn off and unplug electrical device(s). Wait 5 minutes, then press the circuit breaker to reset. Check the total wattage of the devices and reduce the load if it exceeds the capacity of the generator. Then plug the loads back in one by one.
	2. Bad connecting cords/wires.	2. Check the power cords and extension cords. Do not use if any cord is damaged. Replace damaged cords immediately
	3. Bad electrical device connected to the generator.	3. Try connecting a different device.
	4. Carbon brushes are worn or need adjustment.	4. Check carbon brushes, adjust so that both brushes extrude the same length, or replace if worn. For instructions, visit <a href="http://bit.ly/wencarb">bit.ly/wencarb</a> .
	5. Bad voltage regulator	5. Contact customer service at <b>1-800-232-1195</b> for assistance.

**NOTE:** Turn off the generator and wait for it to cool down before performing the maintenance solutions.

**IMPORTANT:** Repairs and replacements should only be performed by an authorized technician. Parts and accessories that wear down over the course of normal use are not covered by the two-year warranty.

# TROUBLESHOOTING GUIDE

**⚠ WARNING!** Stop using the generator immediately if any of the following problems occur or risk serious personal injury. If you have any questions, please contact customer service at **1-800-232-1195** (M-F 8-5 CST), or email [techsupport@wenproducts.com](mailto:techsupport@wenproducts.com).

<b>Generator runs but does not support all electrical devices connected.</b>	1. Generator is overloaded.	1. Turn off and unplug all electrical devices. Wait 5 minutes, then press the circuit breaker to reset. Reduce load as necessary, then plug devices back in one by one.
	2. Short circuit in one of the devices.	2. Try disconnecting any faulty or short circuited electrical loads.
	3. Air filter is dirty	3. Clean or replace the air filter element. Refer to "Inspecting / Cleaning The Air Filter" on page 29.
<b>Engine is "Hunting" during operation (Engine RPM is fluctuating).</b>	1. The fuel isn't running through the fuel valve	1. Check if the fuel is properly and consistently going through the fuel valve
	2. The air filter is clogged.	2. Check for any blockage in the air filter. Check and clean the air filter as necessary.
	3. The muffler or spark arrestor is blocked.	3. Check if the spark arrestor is blocked. Clean with metal brush as necessary.
	4. There is gunk in the carburetor preventing a consistent fuel/air mixture.	4. Use "gunk remover" spray on the carburetor jets.
<b>Remote start does not work.</b>	1. Battery is disconnected.	1. Connect battery. See section "CONNECT THE BATTERY" on p. 16.
	2. Remote batteries drained.	2. Replace batteries. The remote takes 2 CR2016 batteries.
	3. Remote has not been paired with the generator.	3. Pair the remote with the generator. See section "USING THE REMOTE-START FUNCTION" on p. 20.
	4. Generator is in sleep mode.	4. Put the generator in standby mode. See section "STANDBY MODE" on p. 21.
	5. Out of range.	5. You must be within 164 ft (50 m) of the generator for the signal to work properly. The signal may be weaker if the batteries are old.
	6. Engine switch is not set to ON.	6. Set engine switch to ON.
	7. Defective remote.	7. Contact customer service at <b>1-800-232-1195</b> for assistance.
	8. Defective receiver.	8. Contact customer service at <b>1-800-232-1195</b> for assistance.

# WIRING DIAGRAM

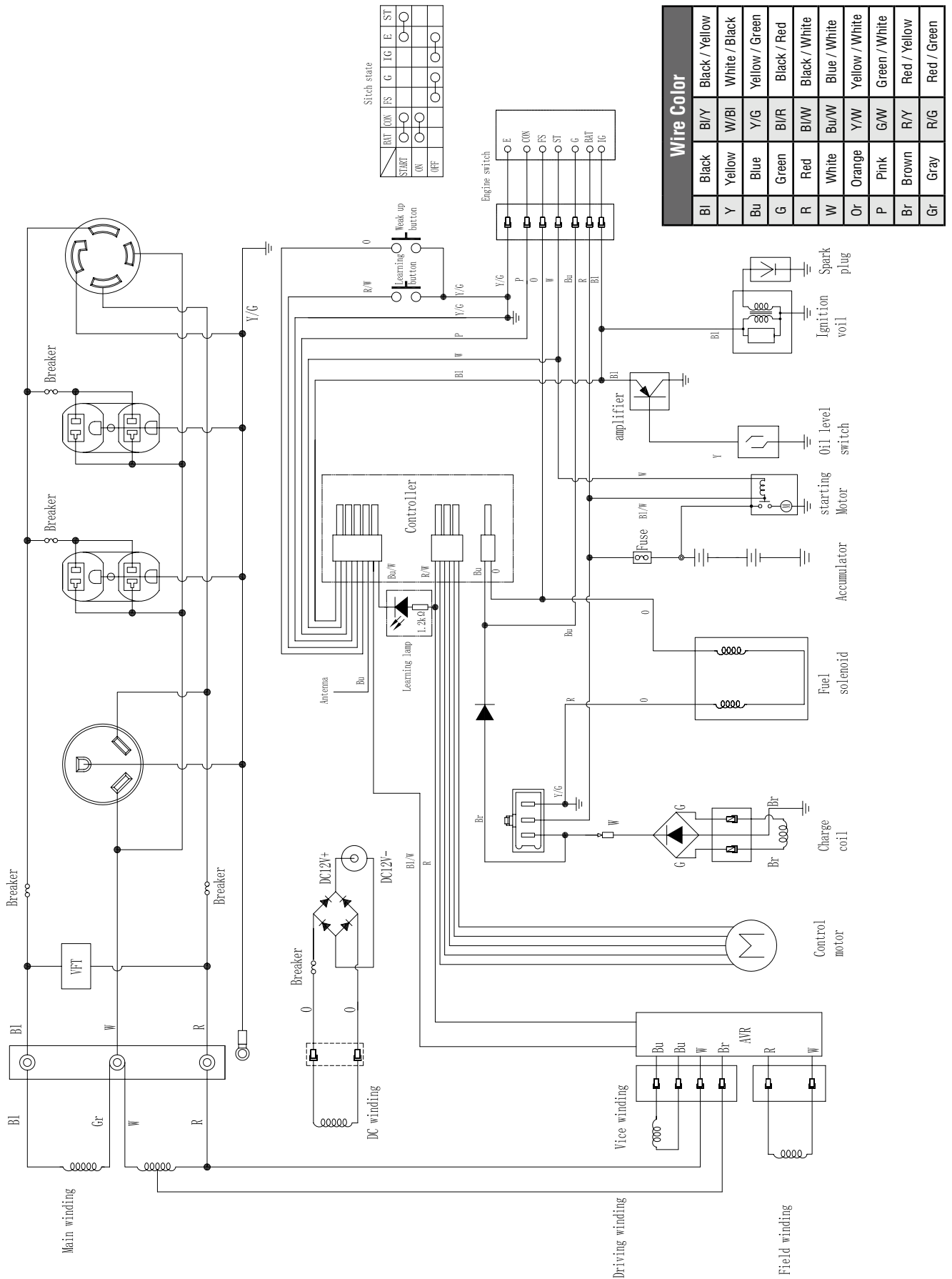

# EXPLODED VIEW & PARTS LIST

## GENERATOR

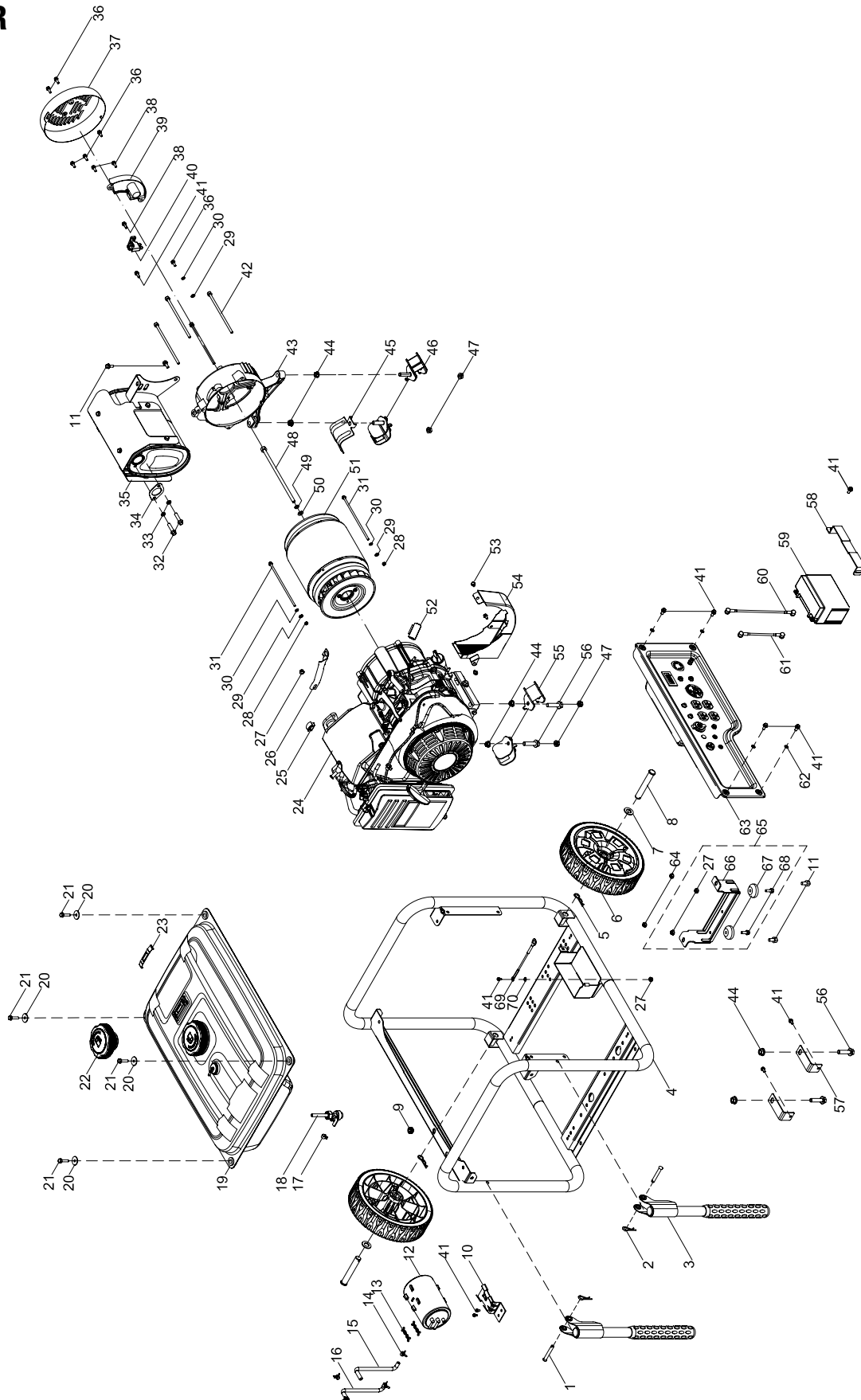

# EXPLODED VIEW & PARTS LIST

## GENERATOR

NO.	PART NO.	DESCRIPTION	QTY.
1	GN9500-001	Pin, Ø8x55	2
2	56500-004	R-clip, Handle	2
3	GN9500-003	Handle	2
4	GN9500-004	Frame Assembly	1
5	56500-007	R-clip, Axle	2
6	GN9500-006	Wheel	2
7	GN9500-007	Washer, Wheel	2
8	GN9500-008	Pin, Ø16x100	2
9	56500-010	Damping Pad	1
10	GN9500-010	Carbon Tank Bracket	1
11	56500-060	Bolt, M8x16	4
12	GN9500-012	Carbon Tank	1
13	56500-047	Clamp A	2
14	56500-052	Clamp A, Carbon Tank	2
15	GN9500-015	Tube A, Carbon Tank	1
16	GN9500-016	Tube B, Carbon Tank	1
17	GN9500-017	Clamp	1
18	GN9500-018	Fuel Valve	1
19	GN9500-019	Fuel Tank Assembly	1
20	GN9500-020	Washer	4
21	GN9500-021	Bolt, M6x25	4
22	GN9500-022	Fuel Tank Cap	1
23	GN9500-023	Fuel Gauge Clip	1
24	GN9500-024	Engine Assembly	1
25	GN9500-025	Plug	1
26	GN9500-026	Air Filter Bracket	1
27	56500-044	Nut, M6	3
28	GN9500-028	Nut, M5	2
29	GN9500-029	Flat Washer, 5mm	3
30	GN9500-030	Lock Washer, 5mm	3
31	GN9500-031	Bolt, M5x229	2
32	GN9500-032	Bolt, M8x32	2
33	GN9500-033	Washer	2
34	GN9500-034	Gasket, Muffler	1
35	GN9500-035	Muffler Assembly	1
N.P.	GN9500-035.1	Spark Arrestor Assembly	1

NO.	PART NO.	DESCRIPTION	QTY.
N.P.	GN9500-035.2	Bolt, M5x8	2
36	GN9500-036	Bolt, M5x14	6
37	GN9500-037	End Cover	1
38	GN9500-038	Bolt, M5x18	3
39	GN9500-039	Voltage Regulator	1
40	GN9500-040	Carbon Brush Assembly	1
41	56500-022	Bolt, M6x12	7
42	GN9500-042	Bolt, M6x194	4
43	GN9500-043	Rear Bracket	1
44	GN9500-044	Nut, M10-1.25	4
45	GN9500-045	Damping Bracket Guard	1
46	GN9500-046	Damping Bracket, Rear	2
47	GN9500-047	Nut, M8	4
48	GN9500-048	Bolt, M10-1.25x280	1
49	GN9500-049	Lock Washer, 10mm	1
50	GN9500-050	Flat Washer, 10mm	1
51	GN9500-051	Alternator Assembly	1
52	GN9500-052	Clip	1
53	GN9500-053	Bolt, M5x10	3
54	GN9500-054	Crankcase Cover	1
55	GN9500-055	Damping Bracket, Front	2
56	GN9500-056	Bolt, M10-1.25x40	2
57	GN9500-057	Shipping Bracket	2
58	GN9500-058	Battery Bracket	1
59	GN9500-059	Battery, 9Ah	1
60	GN9500-060	Positive Lead (Red)	1
61	GN9500-061	Negative Lead (Black)	1
62	GN9500-062	Washer	4
63	GN9500-063	Control Panel Assembly	1
64	56500-056	Nut, M8	2
65	GN9500-065	Support Base Assembly	1
66	GN9500-066	Support Base	1
67	GN9500-067	Rubber Foot	2
68	GN9500-068	Bolt, M6x18	2
69	GN9500-069	Grounding Wire	1
70	GN9500-070	Washer, 6mm	1

# EXPLODED VIEW & PARTS LIST

## ENGINE

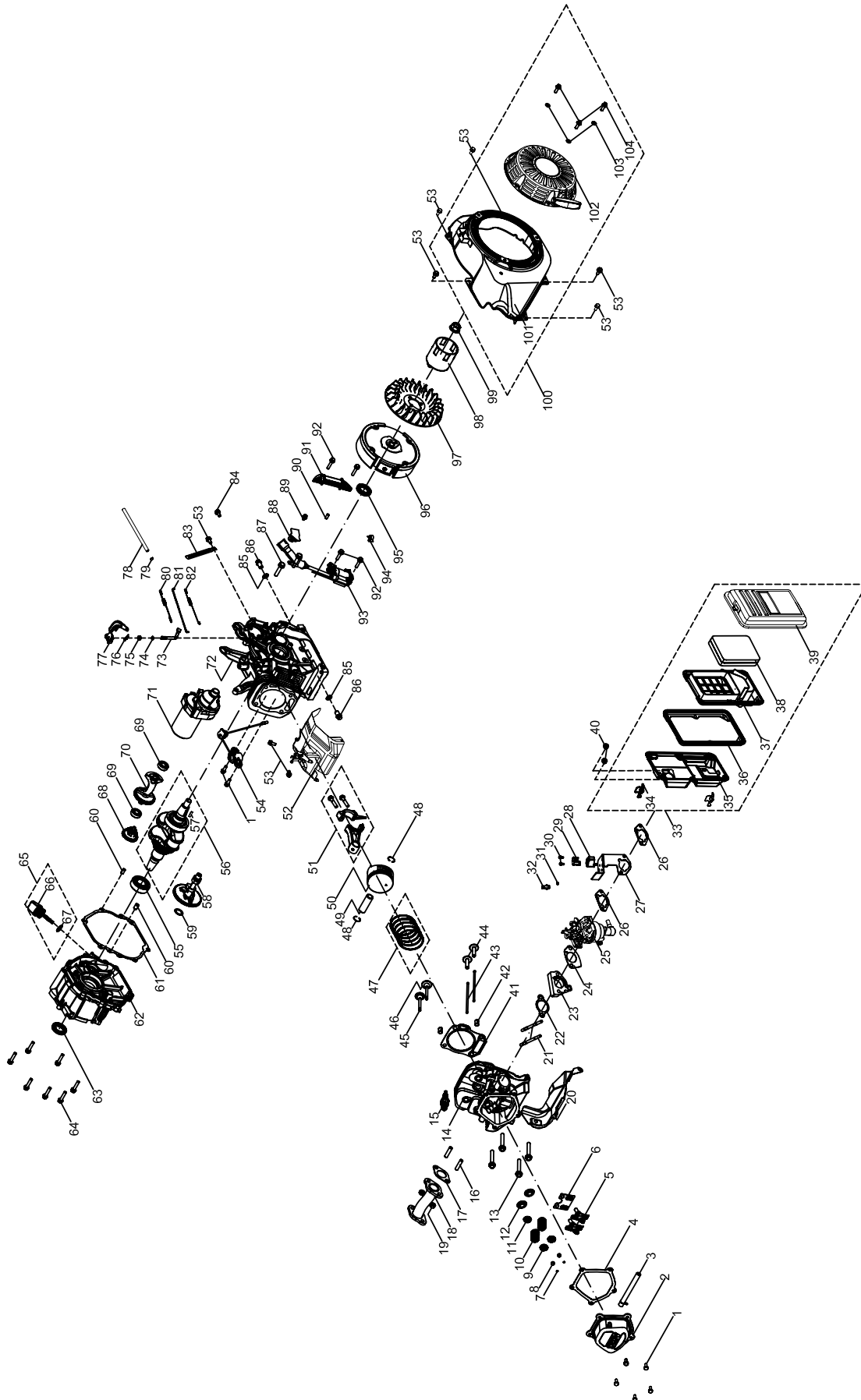

# EXPLODED VIEW & PARTS LIST

## ENGINE

NO.	PART NO.	DESCRIPTION	QTY.
1	GN9500-101	Bolt, M6x16	7
2	GN9500-102	Cylinder Head Cover	1
3	GN9500-103	Breather Tube	1
4	GN9500-104	Gasket, Cylinder Head Cover	1
5	GN9500-105	Rocker Arm Assembly	2
6	GN9500-106	Rocker Arm Base	1
7	GN9500-107	Valve Locking Clip	4
8	GN9500-108	Valve Adjustment Cap, Exhaust	2
9	GN9500-109	Valve Spring Seat, Upper	2
10	GN9500-110	Valve Spring Seat	2
11	GN9500-111	Intake Valve Seal	1
12	GN9500-112	Valve Spring Seat, Lower	2
13	GN9500-113	Bolt, M10-1.25x87	4
14	GN9500-114	Cylinder Head	1
15	56500-123	Spark Plug (Torch F6TC/NGK BP6ES)	1
16	GN9500-116	Stud, M8x35	2
17	GN9500-117	Gasket, Exhaust Tube	1
18	GN9500-118	Exhaust Tube	1
19	GN9500-119	Nut, M8	2
20	GN9500-120	Shroud	1
21	GN9500-121	Stud, M6-0.8x110	2
22	GN9500-122	Gasket, Carburetor Insulator	1
23	GN9500-123	Insulator	1
24	GN9500-124	Gasket, Carburetor	1
25	GN9500-125	Carburetor	1
26	GN9500-126	Gasket, Air Filter	2
27	GN9500-127	Stepper Motor Bracket	1
28	GN9500-128	Auto-Choke Stepper Motor	1
29	GN9500-129	Stepper Motor Cover	1
30	GN9500-130	Screw, M4x8	2
31	GN9500-131	Spring	1
32	GN9500-132	Guide Clamp	1
33	GN9500-133	Air Filter Assembly	1
34	GN9500-134	Air Filter Clip	2
35	GN9500-135	Air Filter Housing	1

NO.	PART NO.	DESCRIPTION	QTY.
36	GN9500-136	Gasket, Air Filter Housing	1
37	GN9500-137	Air Filter Baffle	1
38	GN9500-138	Air Filter Elements (Coarse & Fine)	1
39	GN9500-139	Air Filter Cover	1
40	GN9500-140	Nut, M6	2
41	GN9500-141	Gasket, Cylinder Head	1
42	GN9500-142	Pin, Ø12x20	2
43	GN9500-143	Push Rod	2
44	GN9500-144	Tappet	2
45	GN9500-145	Exhaust Valve	1
46	GN9500-146	Intake Valve	1
47	GN9500-147	Piston Ring Set	1
48	GN9500-148	Circlip	2
49	GN9500-149	Piston Pin	1
50	GN9500-150	Piston	1
51	GN9500-151	Connecting Rod Assembly	1
52	GN9500-152	Governor Gear Bracket Assembly	1
53	GN9500-153	Bolt, M6x12	8
54	GN9500-154	Oil Sensor	1
55	GN9500-155	Ball Bearing, TM6207	1
56	GN9500-156	Crankshaft	1
57	GN9500-157	Woodruff Key	1
58	GN9500-158	Camshaft	1
59	GN9500-159	Washer	1
60	GN9500-160	Pin, Ø8x12	2
61	GN9500-161	Gasket, Crankcase	1
62	GN9500-162	Crankcase Cover	1
63	GN9500-163	Oil Seal, Alternator	1
64	GN9500-164	Bolt, M8x38	7
65	GN9500-165	Dipstick Assembly	1
66	GN9500-166	Dipstick	1
67	GN9500-167	Dipstick O-ring	1
68	GN9500-168	Governor Gear	1
69	GN9500-169	Ball Bearing, 6202	2
70	GN9500-170	Balance Shaft	1
71	GN9500-171	Starter Motor Assembly	1



# EXPLODED VIEW & PARTS LIST

## ENGINE

NO.	PART NO.	DESCRIPTION	QTY.
72	GN9500-172	Crankcase	1
73	GN9500-173	Governor Gear Shaft	1
74	GN9500-174	Washer	1
75	GN9500-175	Oil Seal, Governor	1
76	GN9500-176	Cotter Pin	1
77	GN9500-177	Governor Arm	1
78	GN9500-178	Fuel Hose (Ø4xØ10x190)	1
79	GN9500-179	Clamp	1
80	GN9500-180	Governor Spring	1
81	GN9500-181	Governor Rod	1
82	GN9500-182	Idler Spring	1
83	GN9500-183	Clip	1
84	GN9500-184	Bolt, M6x10	1
85	GN9500-185	Washer	2
86	GN9500-186	Oil Drain Bolt, M12-1.5x15	2
87	GN9500-187	Bolt, M8x35	2

NO.	PART NO.	DESCRIPTION	QTY.
88	GN9500-188	Ignition Coil Plate	1
89	GN9500-189	Bolt, M6x8	1
90	GN9500-190	Bushing	1
91	GN9500-191	Charging Coil	1
92	GN9500-192	Bolt, M6x28	4
93	GN9500-193	Ignition Coil	1
94	GN9500-194	Clip	1
95	GN9500-195	Oil Seal, Flywheel	1
96	GN9500-196	Flywheel	1
97	GN9500-197	Fan	1
98	GN9500-198	Starter Cup	1
99	GN9500-199	Nut, M16-1.5	1
100	GN9500-200	Recoil Starter Assembly	1
101	GN9500-201	Recoil Starter Housing	1
102	GN9500-202	Recoil Starter	1
103	GN9500-203	Washer	3
104	GN9500-204	Bolt, M6x10	3

# EXPLODED VIEW & PARTS LIST

## CONTROL PANEL

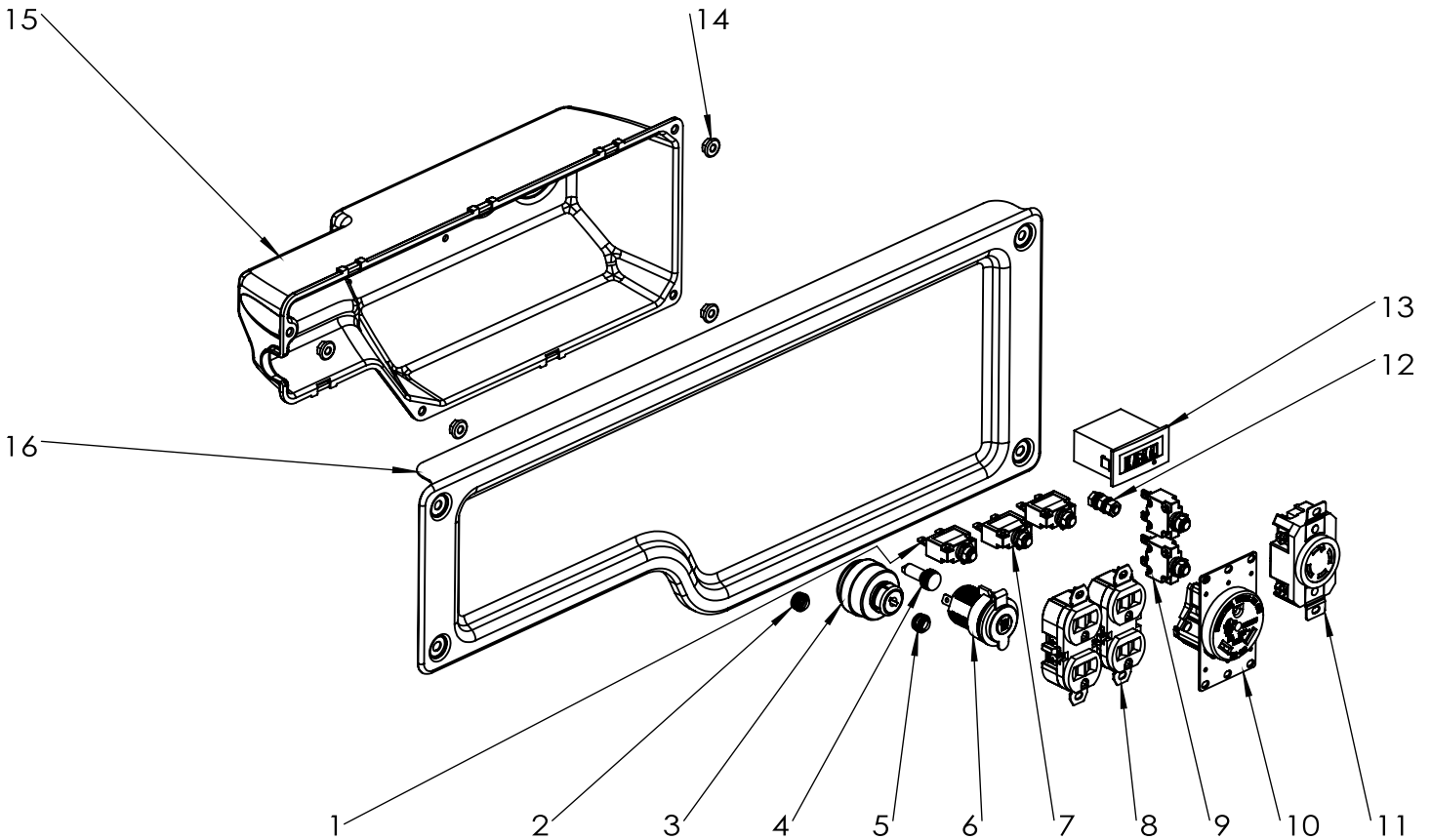

NO.	PART NO.	DESCRIPTION	QTY.
1	GN9500-301	DC Breaker, 10A	1
2	GN9500-302	Remote Reset Button	1
3	GN9500-303	Engine Switch	1
N.P.	GN9500-303.1	Engine Switch Key	1
N.P.	GN9500-303.2	Remote Start Fob	1
4	GN9500-304	Remote Start Pairing Light	1
5	GN9500-305	Remote Pairing Button	1
6	GN9500-306	DC 12V Outlet	1
7	GN9500-307	AC Breaker, 20A	2
8	GN9500-308	AC 120V NEMA 5-20R duplex Outlet	2
9	GN9500-309	AC Breaker, 30A	2

NO.	PART NO.	DESCRIPTION	QTY.
10	GN9500-310	AC 120V NEMA TT-30R RV Outlet	1
11	GN9500-311	AC 120V/240V NEMA L14-30R Outlet	1
12	GN9500-312	Grounding Nut	1
13	GN9500-313	Multi-meter	1
14	GN9500-314	Nut, M6	4
15	GN9500-315	Control Panel Rear Cover	1
16	GN9500-316	Control Panel Base	1
N.P.	GN9500-317	Remote Start Receiver Module	1

# WARRANTY STATEMENT

WEN Products is committed to building tools that are dependable for years. Our warranties are consistent with this commitment and our dedication to quality.

## LIMITED WARRANTY OF WEN PRODUCTS FOR HOME USE

GREAT LAKES TECHNOLOGIES, LLC (“Seller”) warrants to the original purchaser only, that all WEN consumer power tools will be free from defects in material or workmanship during personal use for a period of two (2) years from date of purchase or 500 hours of use; whichever comes first. Ninety days for all WEN products if the tool is used for professional or commercial use. Purchaser has 30 days from the date of purchase to report missing or damaged parts.

SELLER’S SOLE OBLIGATION AND YOUR EXCLUSIVE REMEDY under this Limited Warranty and, to the extent permitted by law, any warranty or condition implied by law, shall be the replacement of parts, without charge, which are defective in material or workmanship and which have not been subjected to misuse, alteration, careless handling, misrepair, abuse, neglect, normal wear and tear, improper maintenance, improper storage, incorrect lubricants/fuels, or other conditions adversely affecting the Product or the component of the Product, whether by accident or intentionally, by persons other than Seller. To make a claim under this Limited Warranty, you must make sure to keep a copy of your proof of purchase that clearly defines the Date of Purchase (month and year) and the Place of Purchase. Place of Purchase must be a direct vendor of Great Lakes Technologies, LLC. Purchasing through third party vendors, including but not limited to garage sales, pawn shops, resale shops, or any other secondhand merchant, voids the warranty included with this product. Contact [techsupport@wenproducts.com](mailto:techsupport@wenproducts.com) or 1-800-232-1195 with the following information to make arrangements: your shipping address, phone number, serial number, required part numbers, and proof of purchase. Damaged or defective parts and products may need to be sent to WEN before the replacements can be shipped out.

Upon the confirmation of a WEN representative, your product may qualify for repairs and service work. When returning a product for warranty service, the shipping charges must be prepaid by the purchaser. The product must be shipped in its original container (or an equivalent), properly packed to withstand the hazards of shipment. The product must be fully insured with a copy of the proof of purchase enclosed. There must also be a description of the problem in order to help our repairs department diagnose and fix the issue. Repairs will be made and the product will be returned and shipped back to the purchaser at no charge for addresses within the contiguous United States.

THIS LIMITED WARRANTY DOES NOT APPLY TO ITEMS THAT WEAR OUT FROM REGULAR USAGE OVER TIME, INCLUDING FILTERS, SPARK PLUGS, VOLTAGE REGULATORS, BRUSHES, GASKETS, O-RINGS, WHEEL KITS, BATTERIES, RECOIL STARTERS, HIGH PRESSURE HOSES, SPRAY GUNS, ETC. ANY IMPLIED WARRANTIES SHALL BE LIMITED IN DURATION TO TWO (2) YEARS FROM DATE OF PURCHASE. SOME STATES IN THE U.S. AND SOME CANADIAN PROVINCES DO NOT ALLOW LIMITATIONS ON HOW LONG AN IMPLIED WARRANTY LASTS, SO THE ABOVE LIMITATION MAY NOT APPLY TO YOU.

IN NO EVENT SHALL SELLER BE LIABLE FOR ANY INCIDENTAL OR CONSEQUENTIAL DAMAGES (INCLUDING BUT NOT LIMITED TO LIABILITY FOR LOSS OF PROFITS) ARISING FROM THE SALE OR USE OF THIS PRODUCT. SOME STATES IN THE U.S. AND SOME CANADIAN PROVINCES DO NOT ALLOW THE EXCLUSION OR LIMITATION OF INCIDENTAL OR CONSEQUENTIAL DAMAGES, SO THE ABOVE LIMITATION OR EXCLUSION MAY NOT APPLY TO YOU.

THIS LIMITED WARRANTY GIVES YOU SPECIFIC LEGAL RIGHTS, AND YOU MAY ALSO HAVE OTHER RIGHTS WHICH VARY FROM STATE TO STATE IN THE U.S., PROVINCE TO PROVINCE IN CANADA AND FROM COUNTRY TO COUNTRY.

THIS LIMITED WARRANTY APPLIES ONLY TO ITEMS SOLD WITHIN THE UNITED STATES OF AMERICA, CANADA AND THE COMMONWEALTH OF PUERTO RICO. FOR WARRANTY COVERAGE WITHIN OTHER COUNTRIES, CONTACT THE WEN CUSTOMER SUPPORT LINE. FOR WARRANTY PARTS OR PRODUCTS REPAIRED UNDER WARRANTY SHIPPING TO ADDRESSES OUTSIDE OF THE CONTIGUOUS UNITED STATES, ADDITIONAL SHIPPING CHARGES MAY APPLY.

**THANKS FOR  
REMEMBERING**

