

## LED WALLPACK

### SPEC SHEET



Catalog No. : LUNA20-PC-4K-BZ

Type : Wallpack

Project Name :

Location :

Qty :

Date :



Suitable for  
Wet Locations



PROBRITE's highly-efficient, maintenance-free Dusk to Dawn LED Wall Pack Light provides a wide, evenly distributed, inviting and secure 4000K natural white light without any unsightly glare or 'hot-spots'. This Dual-Control Enabled light allows the user to choose between two operating modes: a Dusk to Dawn (automatic nighttime ON and daytime OFF) mode or a manual switch-controlled operation for more hands on control. This product offers over 50,000-hour of high-performance LED lighting.

#### APPLICATIONS

Suitable for mounting heights up to 15 ft., this slim-profile wall pack light combines pleasing ambience and functional security lighting ideal for both residential and commercial applications such as entry-ways, patios, apartment complexes, storage areas, driveways, warehouses, loading bays, hotels and perimeter wall lighting.

#### PRODUCT PERFORMANCE AT A GLANCE

SYSTEM WATTAGE	LED WATTAGE	LUMENS	LPW	CRI	REPLACES (MH)
21W	19W	2030 lm	99 lm/w	≥80	50W

#### HOUSING

Die cast aluminum back plate housing with UV-stabilized vandal-resistant polycarbonate front housing and frosted lens.

#### OPTICS

Wide glare-free coverage with even distribution provides inviting security lighting.

#### FINISH

Fade, weather, and abrasion resistant, electrostatically applied, thermally cured, triglycidal isocyanurate (TGIC) textured polyester powdercoat finish with UV-stabilized vandal-resistant polycarbonate front fascade.

#### IP RATING & LISTINGS

LED light engine is weather proof rated IP65.

cULus, FCC Certified

#### MOUNTING

Fits to any standard junction box or direct to any surface via easy knock-outs on the back plate. Also included is a 1/2-inch conduit entry plug located on the bottom of the fixture.

#### WARRANTY

Fixture is covered by a 5-year limited warranty. See [probrite.com/warranty](http://probrite.com/warranty) for details.

## PRODUCT LINE DRAWING

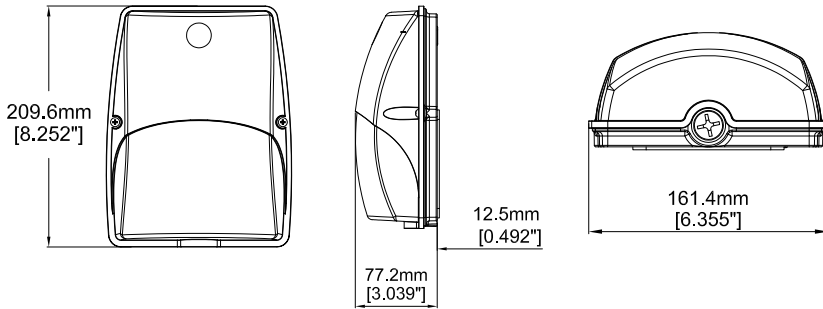

**SUGGESTED MOUNTING HEIGHT:**  
6-15FT. (1.8-4.6M)

## 3D PHOTOMETRIC VIEW

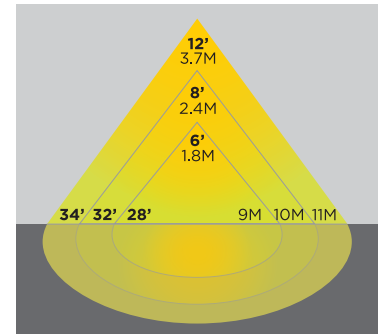

## PRODUCT SPECIFICATIONS

Product Dimensions	: 8.25" x 6.36" x 3.04"
Weight	: 1.76lbs
Lumens	: 2030
System Wattage	: 21W
LED Wattage	: 19W
Efficacy	: 99
CRI	: 80
Replaces (MH)	: 50W
Mounting	: Wall mount
Frequency	: 50-60Hz
THD(Total Harmonic Distortion)	: <20%
PF(Power Factor)	: >0.9
Ambient Operating Temperature	: (-30) - 40°C
Input Voltage	: 120-277V
LED Chip	: Cited COB CLU028
Photocell	: Yes
Driver	: 0-10V Dimming
Standard Lifetime	: L70 >50,000hrs
Standard Warranty	: 5 Years
Water Proofing Grade	: IP65
CCT	: 4000K
Certifications	: DLC, UL/cUL

## 2D PHOTOMETRIC VIEW

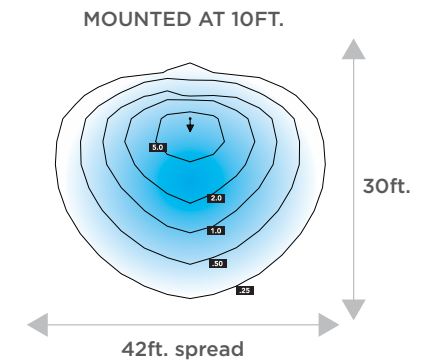

## APPLICATION

