

Item #1002645028
Model #THD1055

EVERBILTTM

USE AND CARE GUIDE

HEAVY DUTY LAUNDRY/SINK TRAY SYSTEM WITH 3/10 HP SUMP PUMP

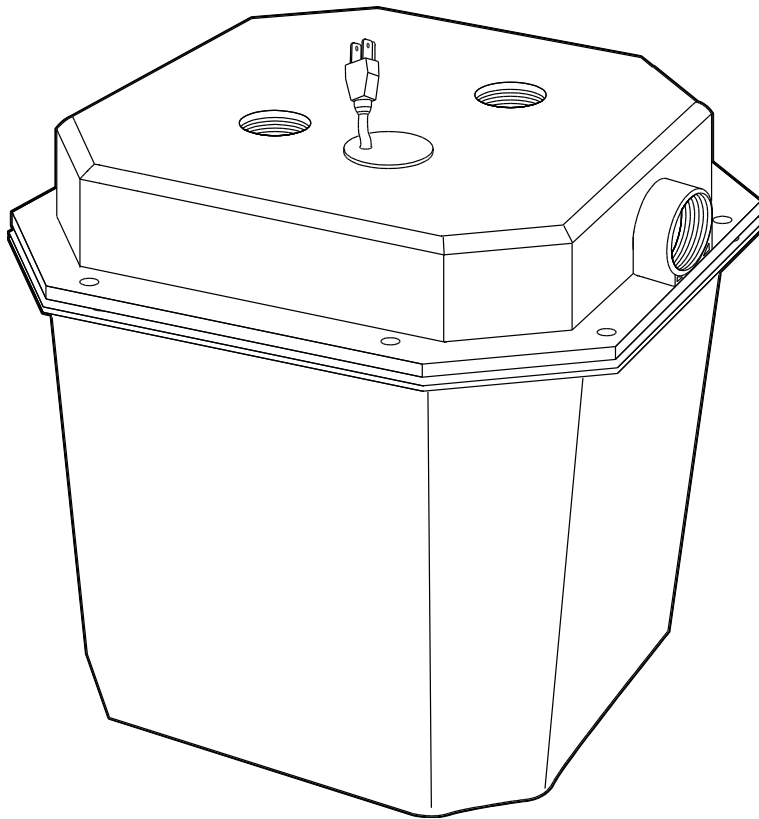

Questions, problems, missing parts? Before returning to the store,
call Everbilt Customer Service
8 a.m. - 7 p.m. EST, Monday - Friday and Saturday 9 a.m. - 6 p.m. EST

1-877-297-6069

HOMEDEPOT.COM

THANK YOU

We appreciate the trust and confidence you have placed in Everbilt through the purchase of this sink/tray system. We strive to continually create quality products designed to enhance your home. Visit us online to see our full line of products available for your home improvement needs. Thank you for choosing Everbilt!

Table of Contents

Table of Contents 2
 Safety Information..... 2
 Precautions **Error! Bookmark not defined.**
 Warranty 3
 Pre-Installation 4
 Application 4

Installation Options 4
 Tools Required..... 5
 Materials Required (Not Included) 5
 Product Description..... 5
Installation 6

Safety Information

Precautions

1. Keep this instruction manual in a safe place for future reference.
2. The motor of this pump has a thermal protector that will trip if the motor becomes too hot. The protector will reset itself once the motor cools down and an acceptable temperature has been reached. The pump may start unexpectedly if it is plugged in.
3. Ensure the electrical power source is adequate for the requirements of the pump.
4. This pump is made of high-strength, corrosion-resistant materials. It will provide trouble-free service for a long time when properly installed, maintained, and used. However, inadequate electrical power to the pump, dirt, or debris may cause the pump to fail. Please carefully read the manual and follow the instructions regarding common pump problems and remedies.

ords present a life threatening safety hazard if the insulation becomes damaged or the connection ends fall into water. The use of an extension cord to power this pump is not permitted.

 **WARNING:** Secure the discharge line before starting the pump. An unsecured discharge line will whip, possibly causing personal injury, and/or property damage.

 **WARNING:** Release all pressure and drain all water from the system before servicing any component.

 **WARNING:** Wear safety goggles at all times when working with pumps.

 **WARNING:** This unit is designed only for use on 115 volts (single phase), 60 Hz, and is equipped with an approved 3-conductor cord and 3-prong grounded plug. Do not remove the ground pin under any circumstances. The 3-prong plug must be directly inserted into a properly installed and grounded 3-prong, grounding-type receptacle. Do not use this pump with a 2-prong wall outlet. Replace the 2-prong outlet with a properly grounded 3-prong receptacle (a GFCI outlet) installed in accordance with the National Electrical Code and local codes and ordinances. All wiring should be performed by a qualified electrician.

 **WARNING:** Protect the electrical cord from sharp objects, hot surfaces, oil, and chemicals. Avoid kinking the cord. Do not use damaged or worn cords.

 **WARNING:** Always electrically ground pump motor to a suitable electrical ground such as a grounded water pipe or a properly grounded metallic raceway system, or to a ground wire system.

 **WARNING:** Failure to comply with the instruction and designed operation of this unit may void the warranty. **ATTEMPTING TO USE A DAMAGED PUMP** can result in property damage, serious personal injury, and/or death.

 **DANGER:** Do not pump flammable or explosive liquids such as oil, gasoline, kerosene, ethanol, etc. Do not use in the presence of flammable or explosive vapors. Using this pump with or near flammable liquids can cause an explosion or fire, resulting in property damage, serious personal injury, and/or death.

 **DANGER:** ALWAYS disconnect the power to the pump before servicing.

 **DANGER:** Do not touch the motor housing during operation. The motor is designed to operate at high temperatures. Do not disassemble the motor housing.

 **DANGER:** Do not handle the pump or pump motor with wet hands or when standing on a wet or damp surface, or in water. If basement floor is wet, do not walk on wet area until all power is turned off. If shut-off box is in basement, call the electric company to shut off service to the house, or call your local fire department for instructions. Remove pump and repair or replace. Failure to follow this warning can result in fatal electrical shock

 **WARNING:** Extension cords may not deliver sufficient voltage to the pump motor. Extension



WARNING: Ensure that the electrical circuit to the pump is protected by a 15 Amp fuse or circuit breaker.



CAUTION: Know the pump and its applications, limitations, and potential hazards.



CAUTION: Do not lift the pump by the power cord.

Safety Information (continued)



CAUTION: Place the pump on a solid base. This will aid in keeping the pump in a vertical orientation. This is critical in keeping the pump operating at maximum efficiency. It will also help prevent the pump from clogging resulting in premature failure.



CAUTION: Follow all safety standards and all local electrical codes.



CAUTION: Periodically inspect the pump and system components to ensure the pump suction screen is free of mud, sand, and debris. Disconnect the pump from the power supply before inspecting.

Warranty

The manufacturer warrants to the original consumer purchaser of the sink tray system that they will be free from defects in material and workmanship for the Warranty Period of 12 months from date of purchase. The date of purchase shall be determined by the original dated sales receipt noting the model number of the system. The original sales receipt must accompany the returned system. If the system fails during the warranty period, disconnect the power, disconnect all plumbing and piping, empty any water from the basin and return the entire system to The Home Depot along with the receipt.

The manufacturer shall not be liable under this Warranty for any product, that, in our sole judgment, has been subject to negligence, misapplication, improper installation, or improper maintenance. Also, the manufacturer shall not be liable under this Warranty if the product has been disassembled, modified, abused or tampered with; if the electrical cord has been cut, damaged or spliced; if the pump discharge has been reduced in size; if the pump has been used in water temperatures above the advertised rating, or water containing sand, lime, cement, gravel or other abrasives; if the product has been used to pump chemicals or hydrocarbons; or if the label bearing the system model has been removed.

Your sole remedy, and the manufacturer's only duty, is that the manufacturer repair or replace defective systems (at the manufacturer's choice). You must pay all labor and shipping charges associated with this warranty. No request for service will be accepted if received after the Warranty Period has expired. This warranty is non-transferable.

The manufacturer shall not be liable for any consequential, incidental, or contingent damages whatsoever. The manufacturer recommends using a professional plumber for all installation and repair, and periodic inspection of the manufacturer's pumps, plumbing connections, and electrical cord. The manufacturer makes no warranty regarding the suitability of a product for a particular installation.

This warranty excludes all industrial, agricultural, commercial and business usage of this system.

The foregoing warranties are exclusive and in lieu of all other express and implied warranties, including but not limited to the implied warranties of merchantability and fitness for a particular purpose. The foregoing warranties shall not extend change to beyond the duration expressly provided herein.

Some states do not allow the exclusion or limitation of incidental or consequential damages or limitations on the duration of the implied warranty, so the above limitations or exclusions may not apply to you. This warranty gives you specific legal rights and you may also have other rights which may vary from state to state. This warranty applies to only pumps installed in the United States of America and Canada.

This warranty supersedes and replaces all previous warranty publications.

Contact the Customer Service Team at 1-877-297-6069 or visit www.HomeDepot.com.

Pre-Installation

Application

This sink tray system is designed for home application. Use this system only for pumping water. This system has not been tested or approved for use in swimming pools or in salt-water marine areas. It is also not engineered to be run continuously as a “fountain” or “waterfall” pump.

Installation Options



WARNING: To prevent lint from the washing machine’s discharge from clogging the pump and causing a flood, cover the end of the discharge hose from the washing machine with a nylon stocking or filter. Regularly check nylon stocking or filter for accumulation of lint that may prohibit proper water flow from the washing machine and replace as needed.

Installation for Laundry Sinks and Washing Machines – Typical

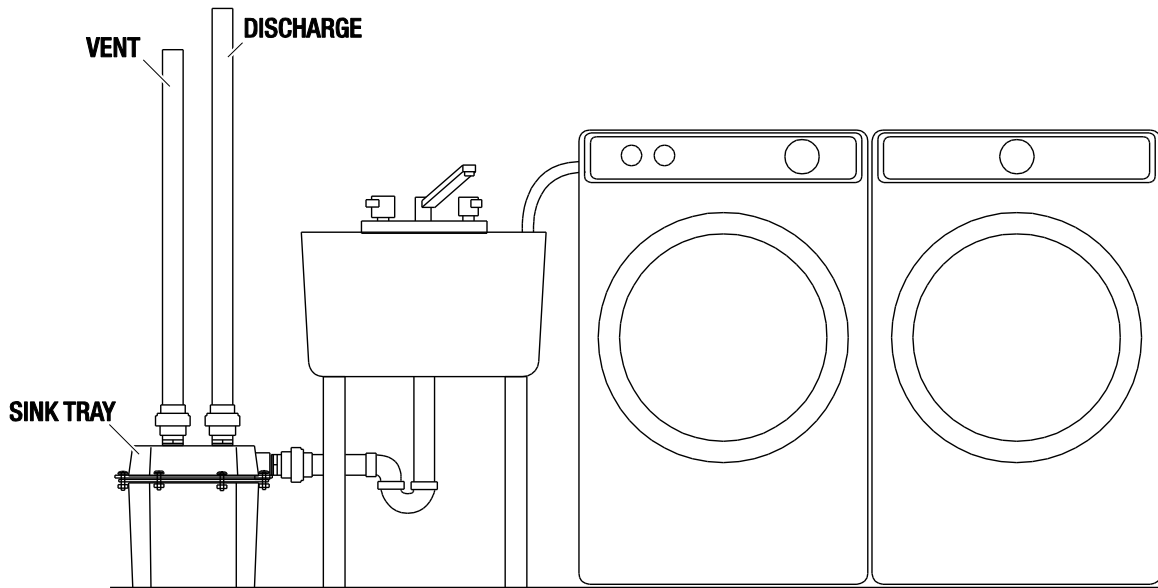

Installation for Wet Bar – Typical

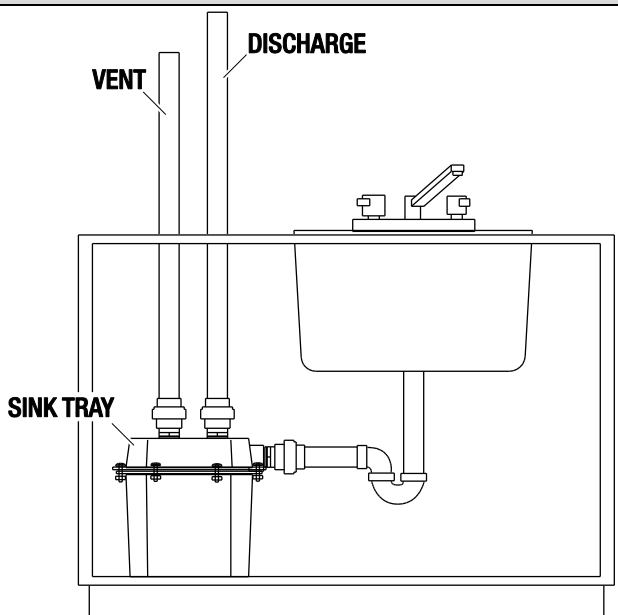

Installation to Remove Air Conditioner Condensate or Humidifier Water - Typical

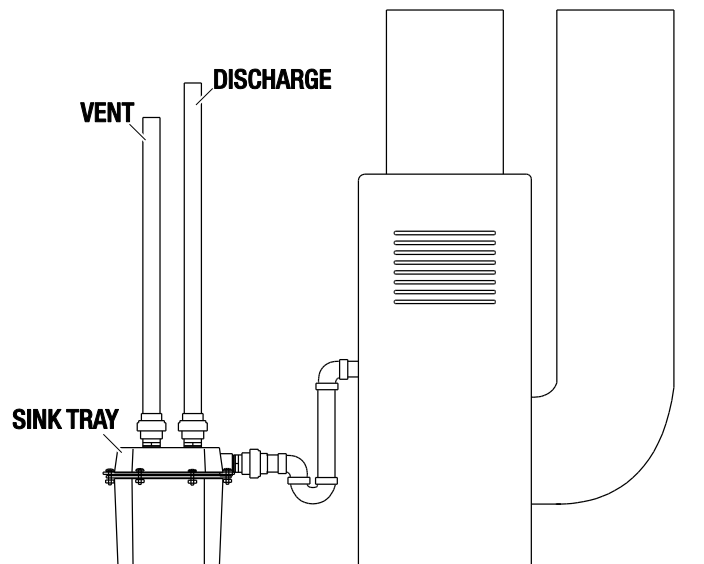

Pre-Installation (continued)

Tools Required

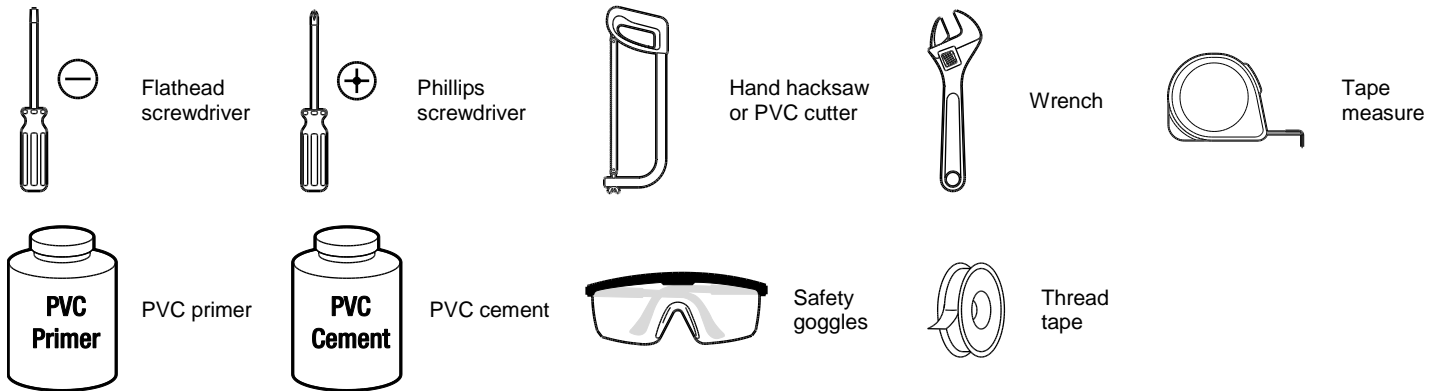

Materials Required (not included)

Before using this pump, ensure you have the following items:

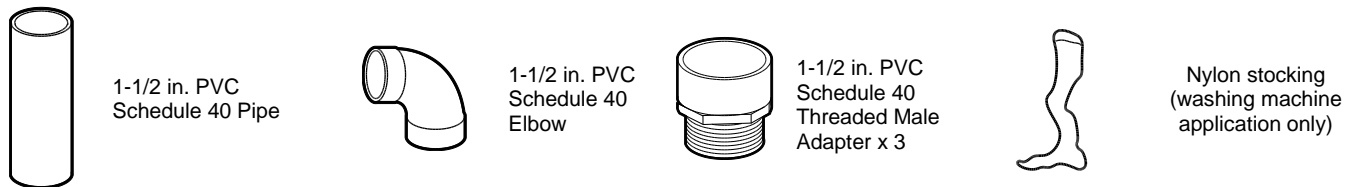

Product Description

Part	Description
A	Basin lid with bolts
B	Cord grommet
C	Lid gasket
D	Sump pump check valve and discharge pipe assembly
E	Basin with bolt inserts
F	Discharge pipe seal
G	3/10 HP Sump Pump with Vertical Switch

Ready Unit for Installation

- Remove basin lid A and discard all packing materials.
- Install discharge pipe assembly D into the threaded discharge opening in pump G. Use Teflon tape, silicon sealant or plumber's pipe dope to seal the threads.
- Press discharge pipe seal F into the discharge socket on the underside of basin lid A.
- Place gasket C onto basin E, aligning the holes.
- Pull pump cord all the way through the cord opening in lid A as shown.
- Place the discharge socket of lid A over discharge pipe D and position the pump so that its float does not touch the basin walls and the bolts of lid A are aligned with the inserts of basin E.
- Tighten the bolts of lid A. Make sure lid gasket C is in place as shown.
- Pull any slack out of the pump cord and make sure it does not interfere with float operation. Install the cord in grommet B and press into the opening in lid A. Your unit is ready for installation.

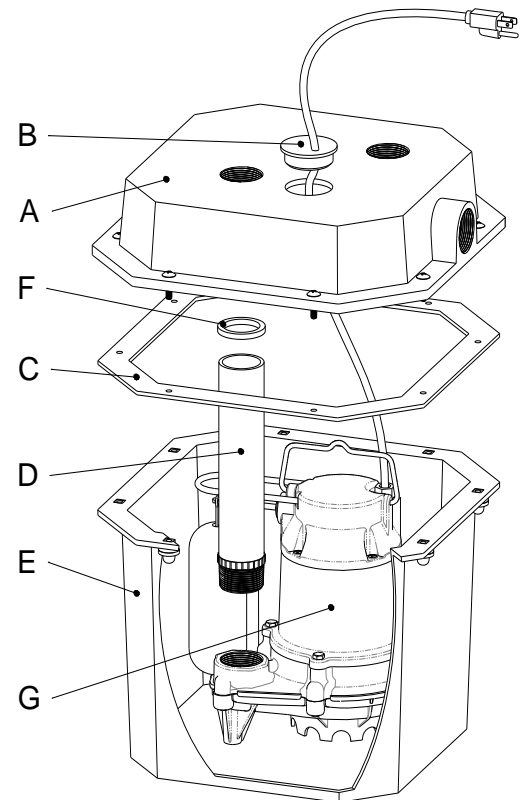

Installation

1 Attaching the inlet connection

- Install a 1-1/2 in. PVC Schedule 40 threaded male adaptor (1) (not included) into the basin's inlet hole (2) as shown. Use Teflon tape, silicon sealant or plumber's pipe dope to seal the threads.
- Connect the inlet piping (3) (not included) to the 1-1/2 in. PVC Schedule 40 threaded male adaptor (1) using PVC primer and solvent cement to properly seal the connection.

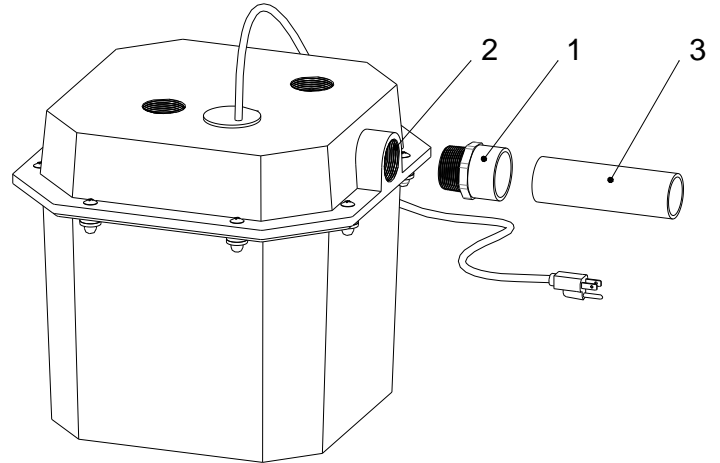

2 Attaching the discharge pipe connection

- Install a 1-1/2 in. PVC Schedule 40 threaded male adaptor (1) (not included) into the discharge hole as shown. Make sure that it is the discharge and not the vent port. Use Teflon tape, silicon sealant or plumber's pipe dope to seal the threads.
- Connect 1-1/2 in. PVC schedule 40 pipe (2) (not included) and elbow (3) (not included) to the male adaptor (1). Use PVC primer and solvent cement to properly seal the connection.
- Connect discharge piping to the 1-1/2 in. PVC Schedule 40 elbow (3) using PVC primer and solvent cement to properly seal the connection. Continue discharge piping to sewer pipe or final out-fall. We suggest that a union be installed on this line to allow for easy pump service or removal.

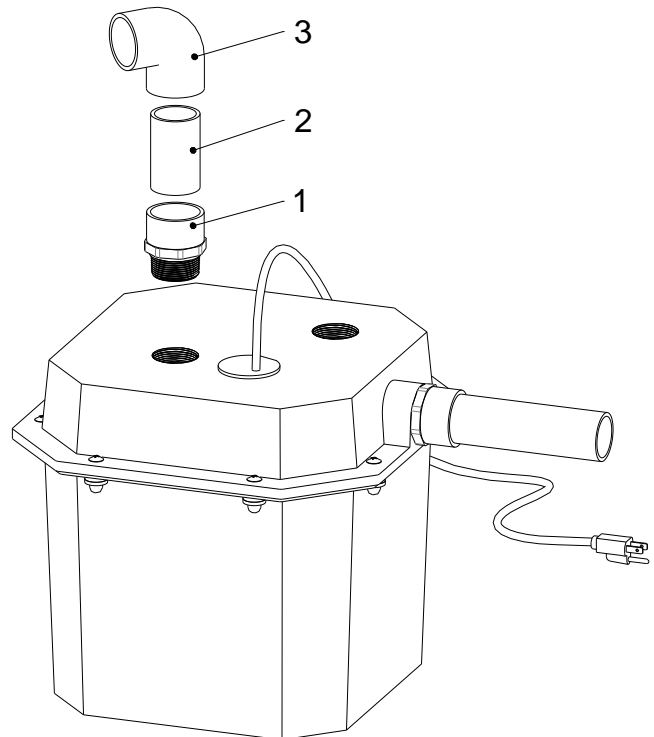

Installation (continued)

3 Attaching the vent connection

- Install a 1-1/2 in. PVC Schedule 40 threaded male adaptor (1) (not included) into the vent hole as shown. Use Teflon tape, silicon sealant or plumber's pipe dope to seal the threads.
- Connect a vent pipe (2) (not included) to the 1-1/2 in. PVC Schedule 40 threaded male adaptor (1) using PVC primer and solvent cement to properly seal the connection. Connect the vent pipe to the sewer's vent system. We suggest that a union be installed on this line to allow for easy pump service or removal.

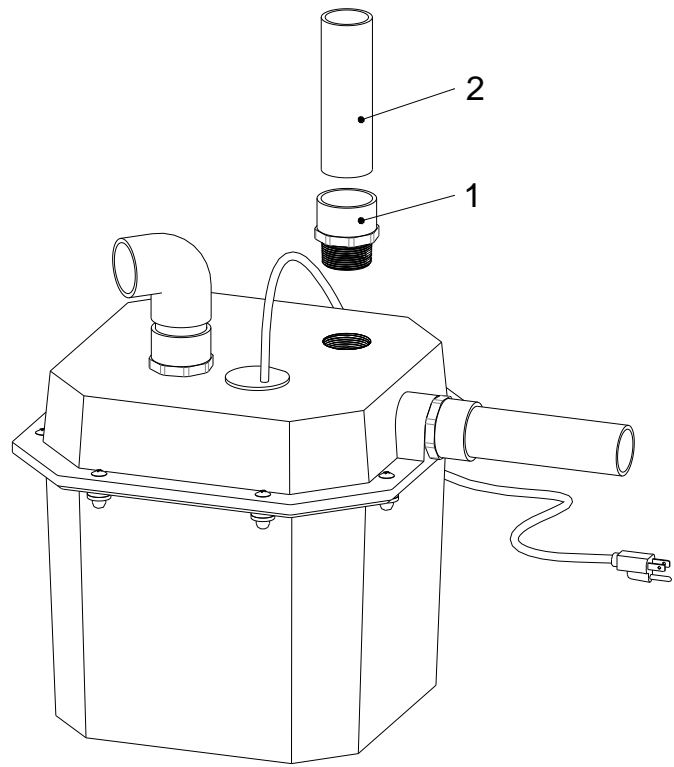

4 Connecting the power and verifying proper operation

- Make sure that the cord grommet is properly inserted into the lid. This assures a water and gas tight seal.
- Plug the power plug into a 115V GFCI power outlet.
- Check the pump by filling the sink tray basin with water and observe the pump's operation through one complete cycle.

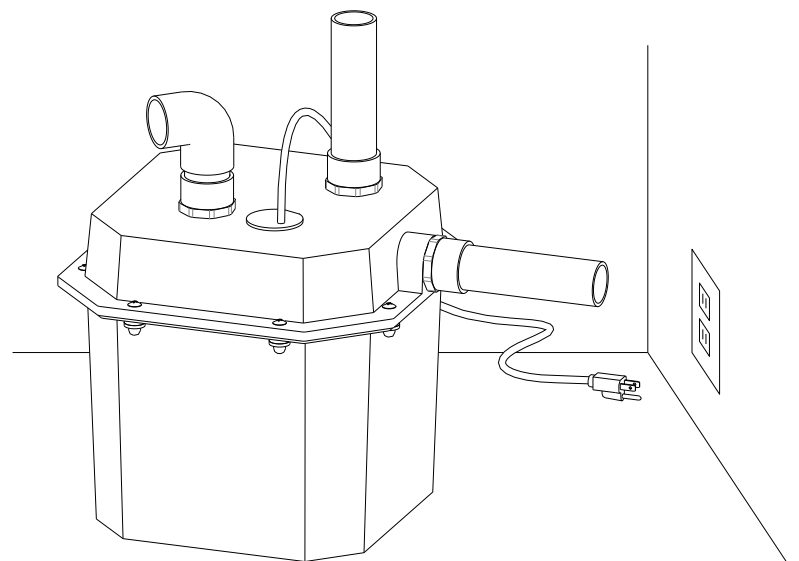



Questions, problems, missing parts? Before returning to the store,
call Everbilt Customer Service
8 a.m. - 7 p.m. EST, Monday - Friday and Saturday 9 a.m. - 6 p.m. EST

1-877-297-6069

HOMEDEPOT.COM

Retain this manual for future use.