

## Model FD05R1/Z Parts list

A = Standard Equipment

O = Circuit Diagram

Item#	Part#	Description	Q'ty	Unit
001	126233-0	SPEED CHANGE LEVER ASSEMBLY	1	PC.
	C10 231433-0	COMPRESSION SPRING 4	2	PC.
002	183B50-3	HOUSING SET	1	
	C10 252126-6	HEX. LOCKING NUT M4-7	2	PC.
	D10	INC. 14		
003	851H34-2	FD05 NAME PLATE	1	
004	266429-2	TAPPING SCREW 3X16	9	PC.
005	232239-9	LEAF SPRING	1	PC.
006	456039-5	F/R CHANGE LEVER	1	
007	632F43-6	SWITCH UNIT	1	
	C10 620463-0	LED CIRCUIT	1	
008	644813-5	TERMINAL	1	
009	251451-2	- PAN HEAD SCREW M5X22	1	PC.
010	763228-8	KEYLESS DRILL CHUCK 10	1	
011	123503-8	GEAR ASS'Y	1	
012	629169-7	DC MOTOR	1	
013	911003-8	PAN HEAD SCREW M3X6	2	PC.
014	183B50-3	HOUSING SET	1	
	C10 252126-6	HEX. LOCKING NUT M4-7	2	PC.
	D10	INC. 2		
A01	251314-2	+ SCREW M4X12	1	PC.
A02	346909-5	HOOK	1	
A04	456128-6	BATTERY COVER	1	(FD05R1)
A05	***DC10WD	DC10WD BATTERY CHARGER	1	(FD05R1)
A06	BL1021B	BATTERY BL1021B	2	(FD05R1)
A07	821661-1	PLASTIC CARRYING CASE	1	(FD05R1)
	C10 417724-5	LATCH	2	PC. (FD05R1)

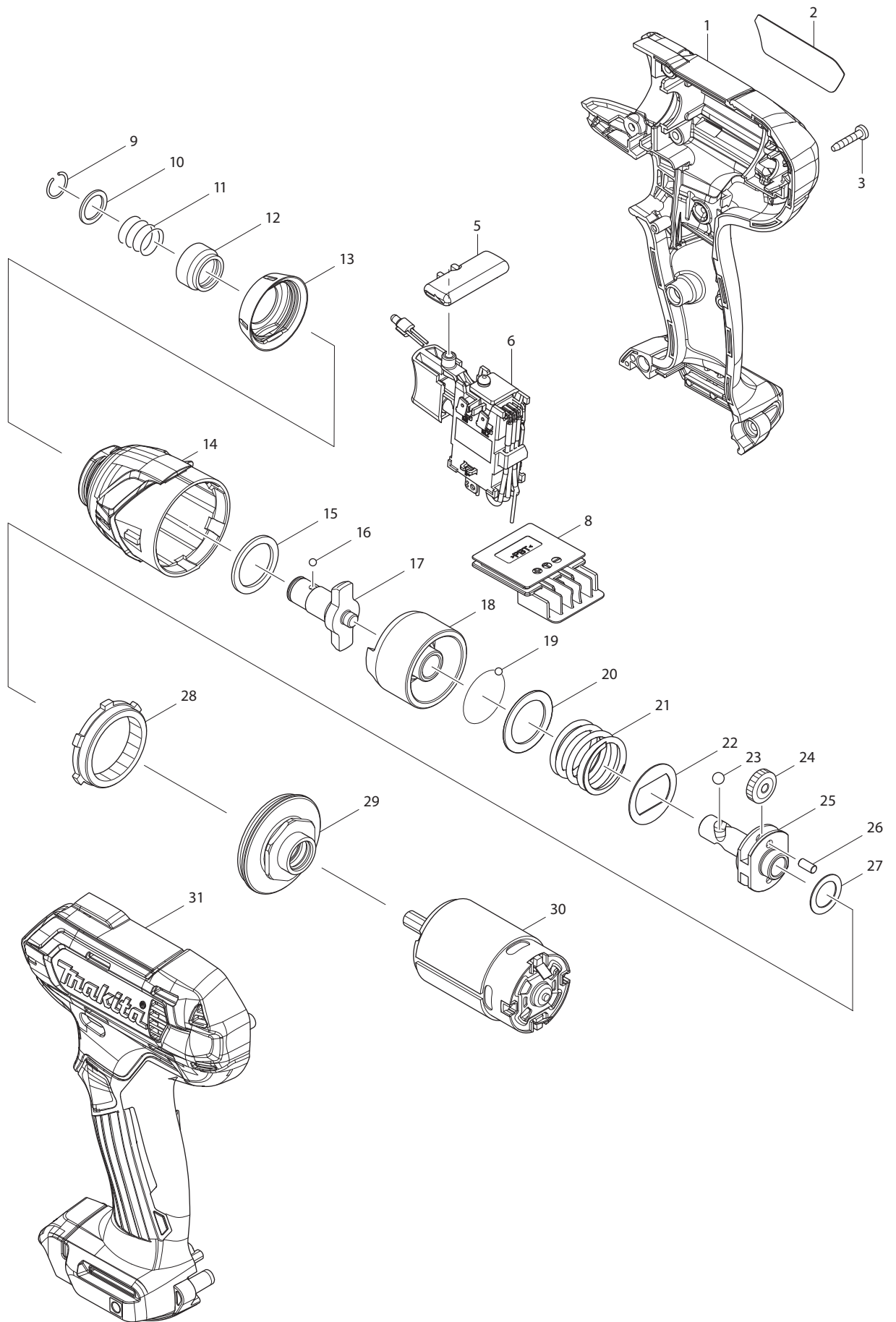

## Model DT03R1/Z Parts List

A = Standard Equipment

O = Circuit Diagram

Item#	Part#	Description	Q'ty	Unit
001	183B49-8	HOUSING SET	1	
	C10 252126-6	HEX. LOCKING NUT M4-7	2	PC.
	D10	INC. 31		
002	851G84-1	DT03 NAME PLATE	1	
003	266429-2	TAPPING SCREW 3X16	8	PC.
005	456039-5	F/R CHANGE LEVER	1	
006	632F43-6	SWITCH UNIT	1	
	C10 620463-0	LED CIRCUIT	1	
008	644813-5	TERMINAL	1	
009	231965-7	RING SPRING 10	1	PC.
010	267143-3	FLAT WASHER 11	1	PC.
011	233005-7	COMPRESSION SPRING 13	1	PC.
012	324711-6	BIT SLEEVE	1	PC.
013	424737-9	BUMPER	1	PC.
014	143277-5	HAMMER CASE COMPLETE	1	
015	261140-1	NYLON WASHER 20	1	PC.
016	216019-1	STEEL BALL 3	2	PC.
017	324895-0	ANVIL M	1	PC.
018	324894-2	HAMMER	1	PC.
019	216019-1	STEEL BALL 3	24	PC.
020	267380-9	FLAT WASHER 20	1	PC.
021	234064-4	COMPRESSION SPRING 21	1	PC.
022	267813-4	WASHER 21	1	PC.
023	216002-8	STEEL BALL 4.8	2	PC.
024	227213-0	SPUR GEAR 17	2	PC.
025	324897-6	SPINDLE	1	PC.
026	268217-3	PIN 3.5	2	PC.
027	253052-2	FLAT WASHER 12	1	PC.
028	227215-6	INTERNAL GEAR 43	1	PC.
029	158671-8	BEARING BOX COMPLETE	1	PC.
030	629163-9	DC MOTOR	1	
031	183B49-8	HOUSING SET	1	
	C10 252126-6	HEX. LOCKING NUT M4-7	2	PC.
	D10	INC. 1		
A01	266622-8	+ TRUSS HEAD SCREW M4X12	1	PC.
A02	346909-5	HOOK	1	
A03	784244-7	+ BIT 2-50	1	PC.
A04	456128-6	BATTERY COVER	1	(DT03R1)
A05	***DC10WD	DC10WD BATTERY CHARGER	1	(DT03R1)
A06	BL1021B	BATTERY BL1021B	2	(DT03R1)
A07	821661-1	PLASTIC CARRYING CASE	1	(DT03R1)
	C10 417724-5	LATCH	2	PC. (DT03R1)
E01	807H20-1	CAUTION LABEL	1	

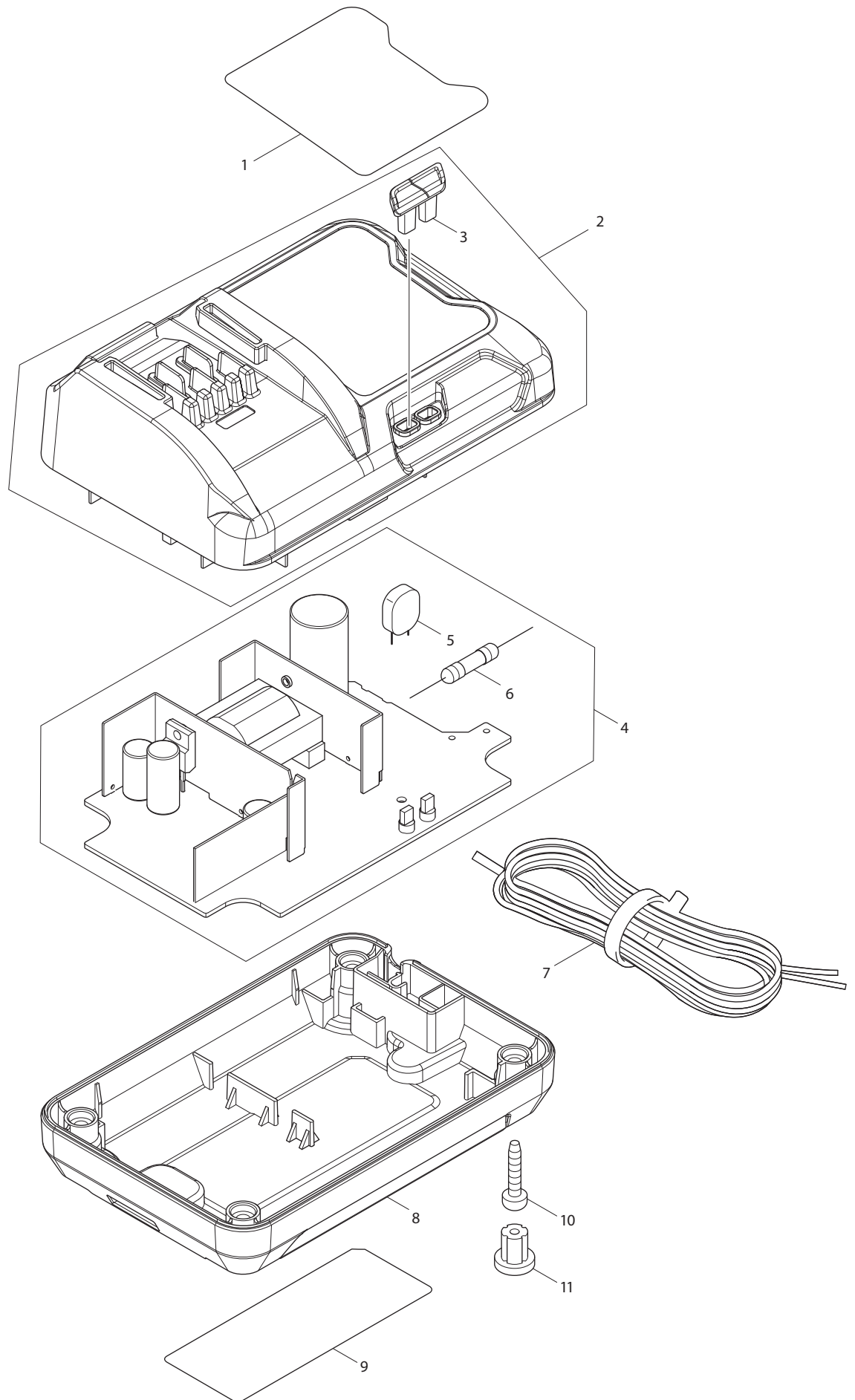

## Model DC10WD Parts List

A = Standard Equipment

O = Circuit Diagram

Item#	Part#	Description	Q'ty	Unit
001	807B57-2	CHARGING CONDITION LABEL	1	PC.
002	143244-0	CHARGER CASE COMPLETE	1	PC.
	D10	INC. 3		
003	455959-0	LENZ	1	PC.
004	620421-6	CHARGING CIRCUIT	1	PC.
	D10	INC. 5,6		
005	647306-1	VARISTOR	1	PC.
006	652804-2	FUSE	1	PC.
007	667982-5	VINYL CORD #18-2-2.0	1	PC.
008	455958-2	CHARGER CASE COVER	1	PC.
010	266346-6	TAPPING SCREW BT 4X20	4	PC.
011	286255-3	CAP 13	4	PC.
E01	807B61-1	CAUTION LABEL	1	