

# FEATURES

## MICROWAVE OVEN FEATURES

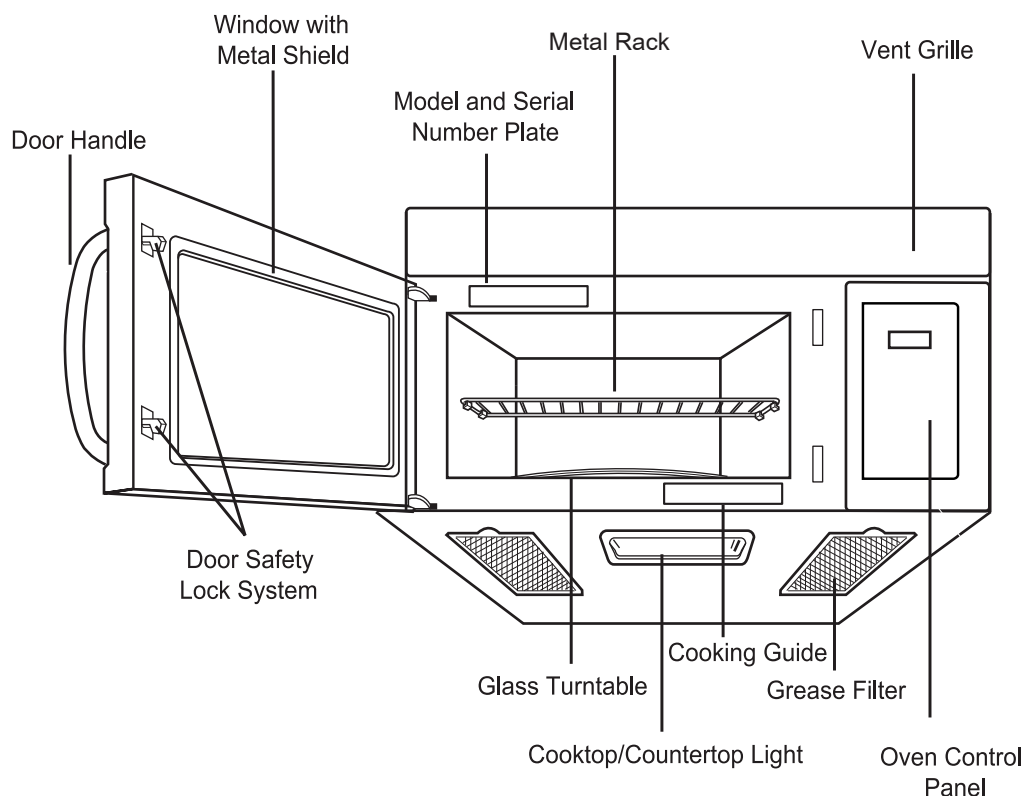

### **⚠ WARNING:**

Do not operate the oven when empty or without the glass tray. It is best to leave a glass of water in the oven when not in use. The water will safely absorb all microwave energy, if the oven is accidentally started.

Your microwave oven is designed to make your cooking experience as enjoyable and productive as possible. To get you up and running quickly, the following is a list of the oven's basic features:

- 1. Metal Shielded Window.** The shield prevents microwaves from escaping. It is designed as a screen to allow you to view food as it cooks.
- 2. Model and Serial Number Plate & Cooking Guide Label**
- 3. Charcoal Filter** (behind Vent Grille)
- 4. Vent Grille**
- 5. Glass Tray.** The glass tray moves food as it cooks for more even cooking. It must be in the oven during operation for best cooking results.
- 6. Cooktop/Countertop Light**
- 7. Control Panel.** Press the buttons on this panel to perform all functions.
- 8. Metal Rack.** Use for extra space when cooking in more than one container at the same time. Remove cooking rack when you are not using it.
- 9. Grease Filter**

# FEATURES

## OVEN CONTROL PANEL

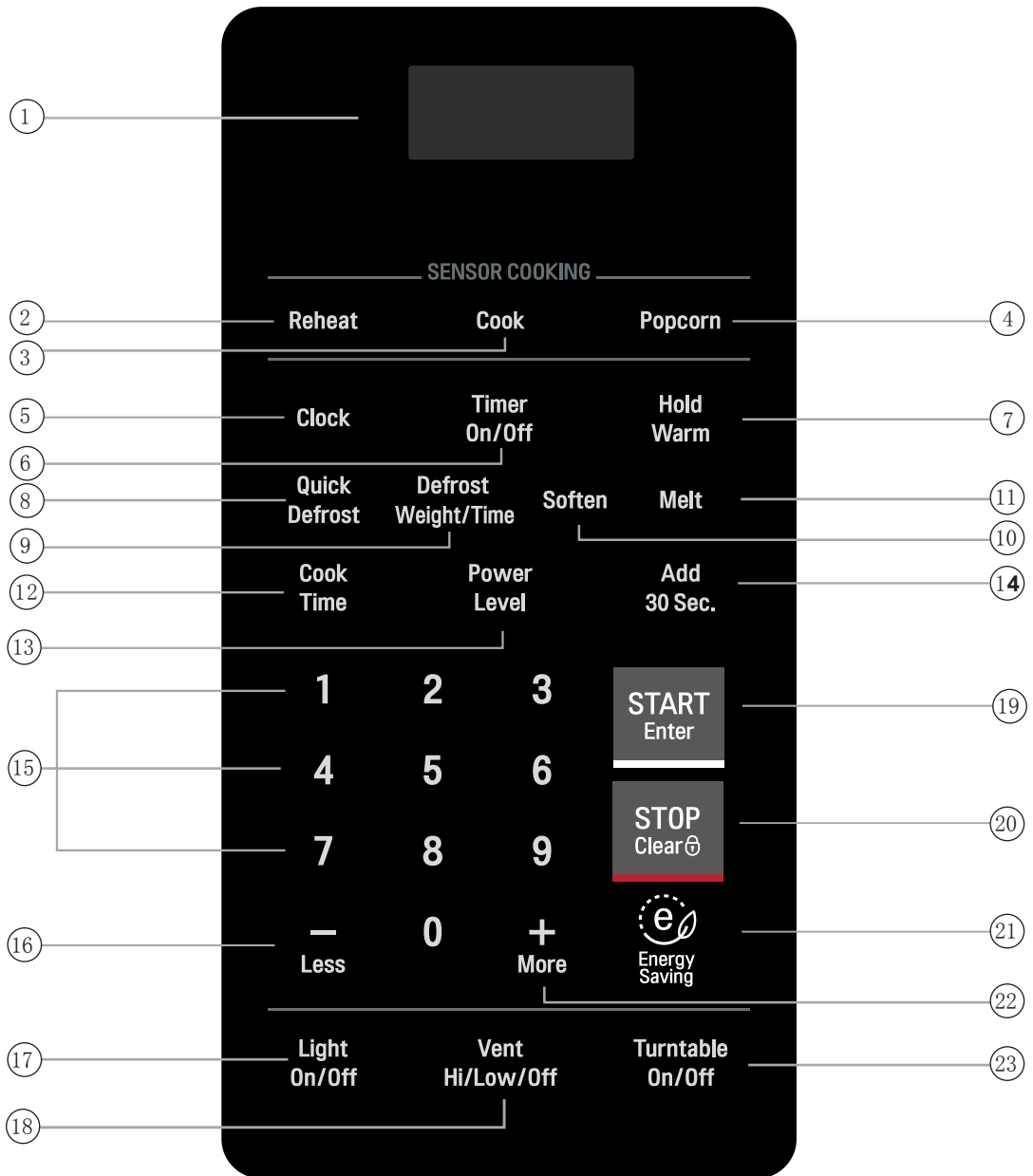

# FEATURES

- 1. Display.** The Display includes a clock and indicators to tell you time of day, cooking time settings and cooking functions selected.
- 2. Reheat.** Press this button to reheat a casserole, dinner plate, and soup/sauce. The oven's sensor will tell the oven how long to cook depending on the amount of humidity it detects from the food.
- 3. Cook.** Press this button to cook frozen lasagna, casseroles, and rice. The oven's sensor will tell the oven how long to cook depending on the amount of humidity it detects from the food.
- 4. Popcorn.** Press this button when popping popcorn in your microwave oven. The oven's sensor will tell the oven how long to cook depending on the amount of humidity it detects from the popcorn.
- 5. Clock.** Press this button to enter the time of day.
- 6. Timer On/Off.** Press this button to set the kitchen timer.
- 7. Hold Warm.** Press this button to keep hot, cooked foods warm in your microwave oven for up to 90 minutes.
- 8. Quick Defrost.** This button provides you with a rapid defrosting method for 1.0 pound frozen foods.
- 9. Defrost Weight/Time.** Press this button followed by number buttons to thaw frozen meat by weight.
- 10. Soften.** Press this button to soften butter, ice cream, cream cheese, frozen juice.
- 11. Melt.** Press this button to melt butter or margarine, chocolate, cheese, and marshmallows.
- 12. Cook Time.** Press this button to set a cooking time.
- 13. Power Level.** Press this button to select a cooking power level.
- 14. Add 30 Sec.** Press this button to add 30 seconds of cooking time each time you press it.
- 15. Number.** Press number buttons to enter cooking time, power level, quantities or weights.
- 16. Less.** Press this button to subtract ten seconds of cooking time each time you press it.
- 17. Light On/Off.** Press this button to turn the cooktop/countertop light on or off.
- 18. Vent Hi/Low/Off.** Press button to turn the vent on or off.
- 19. START/Enter.** Press this button to start a function. If you open the door after the oven begins to cook, press START/Enter again.
- 20. STOP/Clear.** Press this button to stop the oven or clear all entries.
- 21. Energy Saving.** Press this button to save energy.
- 22. More.** Press this button to add ten seconds of cooking time each time you press it.
- 23. Turntable On/Off.** Press this button to turn on/off the turntable. This option is not available in sensor cook, defrost, soften and melt modes.