

INSTALLATION INSTRUCTIONS

For Opener Reinforcement Bracket

Things to Know Before You Begin

Read the instructions provided with the automatic opener prior to starting the installation. Becoming familiar with the components of the opener will reduce the installation time.



WARNING

In the interest of safety this symbol means **WARNING** or **CAUTION**. Personal injury and/or property damage may occur unless instructions are followed carefully.

Consumer Hotline
1-800-225-6729



WARNING

To avoid risk of strangulation or personal injury to children, you must remove the pull down rope when you install an automatic garage door opener.

IMPORTANT: When installing an automatic garage door opener, make sure to follow the manufacturer's installation and safety instructions carefully.

Remove the pull down rope and unlock or remove the lock. If attaching an operator bracket to the wooden anchor pad, make sure the wood anchor pad is free of cracks and splits and is firmly attached to the wall. Always drill pilot holes before installing lag screws.

To avoid damage to your door, you must reinforce the top section of the door in order to provide a mounting point for the opener to be attached. **Failure to reinforce the door as shown here or as shown in the door installation and maintenance instruction manual will void your Clopay Warranty.**

Note: This opener reinforcement bracket can only be used on 8 ft., 9 ft., 12 ft., 16 ft., 17 ft., and 18 ft. wide doors with a 21" high top section. For other door widths, refer to 'Attaching An Automatic Opener' section in the door installation and maintenance manual. An opener reinforcement bracket for 18" high sections is available as a special order item from the retail store where you purchased your garage door.

Step 1 Preparing to install the Opener Reinforcement Bracket

Lock your garage door in the **closed** position. Remove the two fasteners from the top leaf of the hinge that connects the top two door sections together. Refer to Figure 1. Save the fasteners for later use.

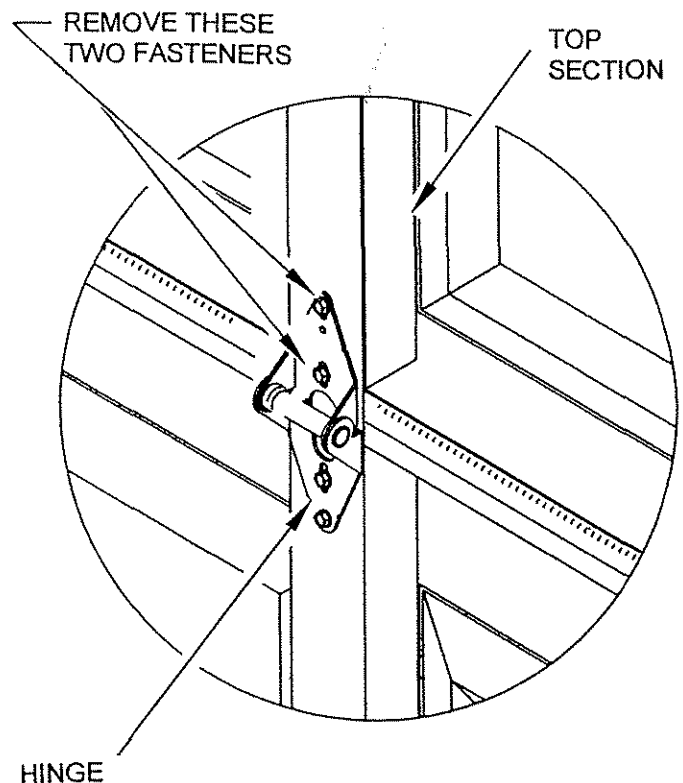

FIGURE 1

Step 2 Attachment of Opener Reinforcement Bracket to door

Place the Opener Reinforcement Bracket on the top section as shown in Figure 2, with the bottom flange of the bracket over the top of the upper leaf of the hinge. Align the mounting slots in the bottom of the bracket with the slots in the hinge and predrilled holes in the door section. Use the two fasteners removed in step 1 above to attach the bracket. Do not completely tighten at this time. Next, align the mounting holes in the top of the bracket with holes in the door section. Secure with the #14 x 5/8" lg. sheet metal screws provided. Finish tightening the bottom fasteners.

If your door has a strut across the top section, place the strut over the top of the Opener Reinforcement Bracket as shown in Figure 3. The strut in Figure 3 is shown cut away for illustration purposes only. Do not notch or cut the strut.

Note: In some cases your door may require horizontal punched angle as well as the Opener Reinforcement Bracket. Refer to 'Attaching an Automatic Opener' section in the door installation and maintenance instruction manual.

Step 3 Attachment of Operator Arm

Attach the operator arm from the automatic opener to the Opener Reinforcement Bracket by placing the operator arm between the tabs on the Opener Reinforcement Bracket as shown in Figure 4. The opener arm should be attached at approximately the same location as the top rollers on the door. This is approximately 3" – 5" from the top of the door. Install the clevis pin through the bracket and arm. Secure the pin with the cotter pin provided.

Note: If your door has a lock installed, make certain it is unlocked prior to operating your automatic opener.

