

PARTS DIAGRAM

MAIN MACHINE

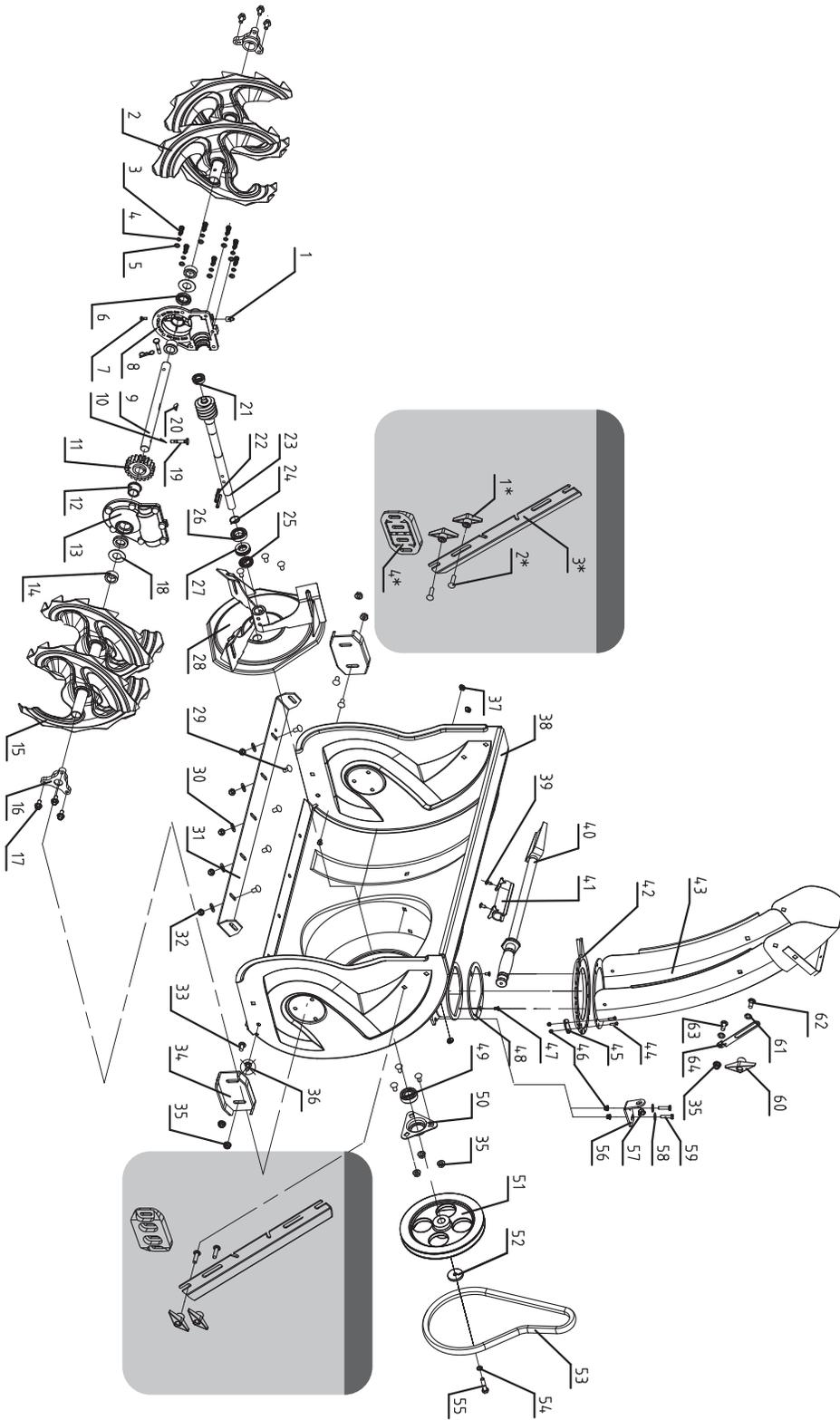

HANDLEBARS

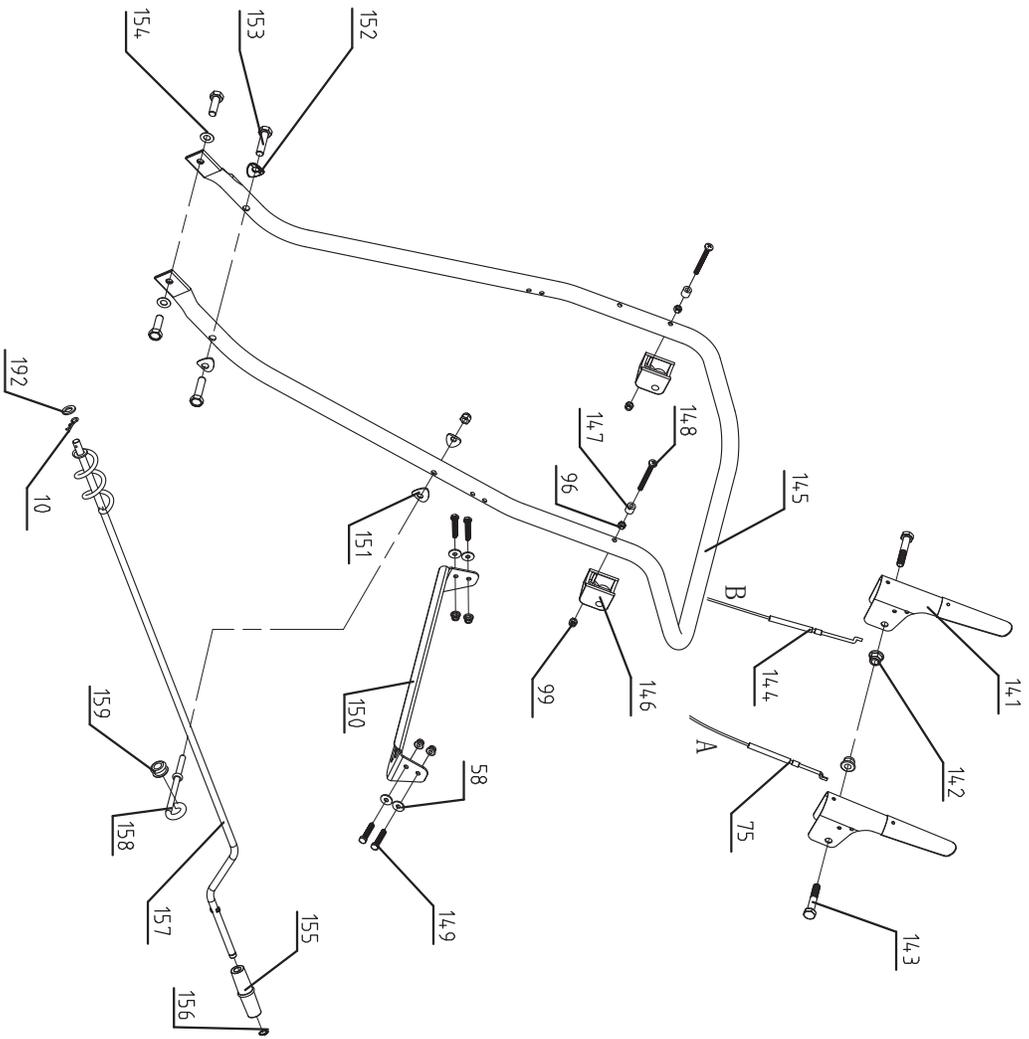

GEARBOX

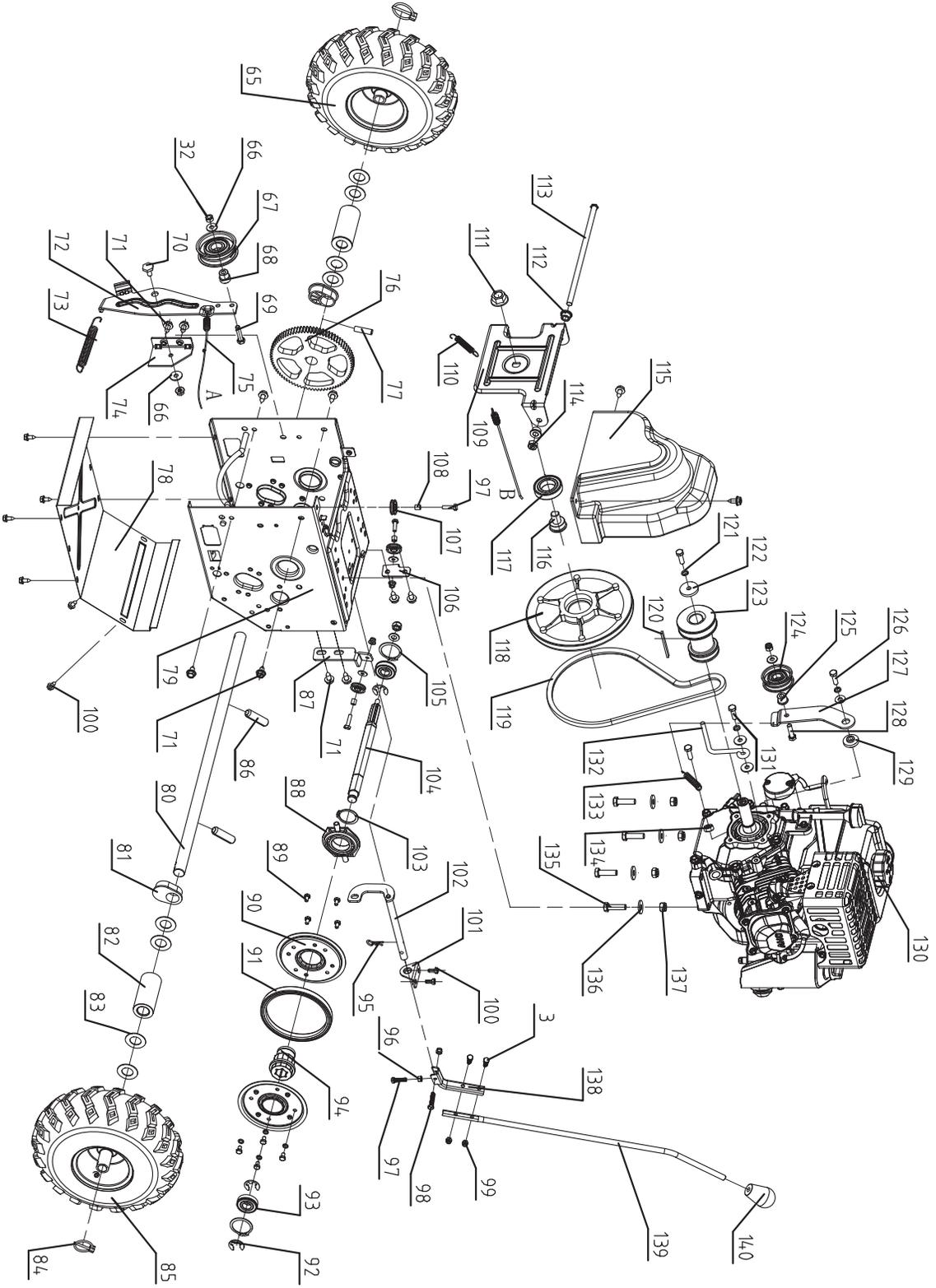

PARTS LIST

No.	Description	Qty	No.	Description	Qty	No.	Description	Qty
1	Oil Seal M10x1	1	37	Plug	5	73	Extension Spring	1
2	Spiral Assembly-Right	1	38	Auger Housing Assy.	1	74	Auger Idler Mounting Bracket	1
3	FT Bolt M6x20	8	39	Screw ST5.5x13	3	75	Friction Wheel Cable	1
4	Spring Washer 6	15	40	Chute Clean-Out Tool	1	76	Big Gear	1
5	Flat Washer 6	10	41	Clean-Out Tool Mounting Bracket	1	77	Pin A6x35	1
6	Seal B20x35x7	2	42	Chute Crank Flange	1	78	Frame Cover	1
7	Screw M5x10	1	43	Discharge Chute	1	79	Gearbox Main Frame	1
8	Auger Gearcase Housing-Right	1	44	FT Bolt M6x30	6	80	Wheel Shaft	1
9	Auger Shaft	1	45	Chute Flange Keeper	3	81	Shaft Bushing	2
10	Clevis Pin 1.8	5	46	Flange Lock Nut M6	12	82	Shaft Spacer	2
11	Worm Wheel	1	47	Screw M5x6	2	83	Wahser	3
12	Shaft Sleeve	2	48	Discharge Chute Washer	1	84	Lock Pin 8	2
13	Auger Gearcase Housing-Left	1	49	Ball Bearing 60203-2RS	1	85	Wheel	1
14	Washer	2	50	Bearing Housing	1	86	Pin 6x36	2
15	Spiral Assembly-Left	1	51	Auger Pulley	1	87	Auger Cable Holder 1	1
16	Bearing Box	2	52	Big Flat Washer 8	2	88	Shift Arm	1
17	Screw ST8x16	6	53	Auger Belt 4LXP960	1	89	FT Bolt M6x10	8
18	Big Washer	2	54	Spring Washer 8	3	90	Friction Wheel Side Plate	2
19	Shear Pin	2	55	Bolt M8x25	1	91	Rubber Ring	1
20	Half Round Key 5x7.5x19	1	56	Chute Crank Bracket	1	92	Snap Ring 15	2
21	Ball Bearing 6001-2RS	1	57	Bushing	1	93	Ball Bearing 60203-2RSN	2
22	Roll Pin 6x37	2	58	Flat Washer 6	8	94	Friction Wheel Hub	1
23	Impeller Shaft	1	59	FT Bolt M6x20	2	95	Clevis Pin 2	1
24	Washer	1	60	Handle Knob Assembly	1	96	Nut M6	3
25	Seal B20x35x7	1	61	Lock Washer	2	97	FT Bolt M6x25	4
26	Ball Bearing 61904-2RS	1	62	Bolt M8x35	1	98	Bolt M6x30	1
27	Thrust Bearing 51104	1	63	Bolt M8x20	1	99	Lock Nut M6	3
28	Impeller Assembly	1	64	Chute Linkage Plate	1	100	Screw M6x16	10
29	Bolt M8x16	5	65	Wheel	1	101	Fork Bracket	1
30	Flat Washer 8	5	66	Flat Washer 8	5	102	Fork Assembly	1
31	Shave Plate	1	67	Auger Idler	1	103	Circlip 35	1
32	Lock Nut M8	9	68	Spacer	1	104	Hex Shaft	1
33	Bolt M8x20	5	69	FT Bolt M8x35	1	105	Circlip 40	2
34	Skid Shoe (Metal)	2	70	Pivot Bolt	1	106	Auger Cable Holder 2	1
35	Hex. Flange Nut M8	9	71	Screw M8x16	12	107	Cable Roller	3
36	Bolt M8x25	2	72	Auger Idler Bracket	1	108	Roller Bushing	3

No.	Description	Qty
109	Driven Pulley Bracket	1
110	Friction Wheel Retaining Spring	1
111	Flange Lock Nut M16x1.5	1
112	Locating Knot	2
113	Locating Shaft	1
114	Flange Lock Nut M10	1
115	Engine Belt Cover	1
116	Driven Pulley Hub	1
117	Ball Bearing 6006-2RS	1
118	Engine Pulley	1
119	Drive Belt	1
120	Key 6X6X45	1
121	Spring Washer 10	1
122	Washer	1
123	Belt Pulley	1
124	Drive Clutch Idler	1
125	Bushing	1
126	Bolt 5/16-24unf	1
127	Drive Clutch Idler Bracket	1
128	FT Bolt M8x30	1
129	Spacer	1
130	Engine	1

No.	Description	Qty
131	Bolt 5/16-24unf	2
132	Belt Blocker	1
133	Extension Spring	1
134	Jam Nut 5/16-24unf	1
135	FT Bolt M8x35	4
136	Flat Washer 10	6
137	Flange Lock Nut M8	4
138	Spring Clip	1
139	Shift Rod	1
140	Operating Handle	1
141	Handle	2
142	Flange Lock Nut M10	2
143	Screw M10x55	2
144	Chute Adjustable Cable	1
145	Rail Handle	1
146	Handle Base	2
147	Handle Locate Jacket	2
148	Screw M6x60	2
149	Screw M6x40	4
150	Control Panel	1
151	Arc Washer 8	2
152	Arc Washer 10	2

No.	Description	Qty
153	FT Bolt M10x40	2
154	FT Bolt M10x20	2
155	Directional Chute Control Lever Knob	1
156	Circlip 10	1
157	Directional Chute Control Lever	1
158	Chute Bracket	1
159	Rubber Spacer	1
160	Washer 10	1

OPTIONAL DRIFT CUTTERS

No.	Description	Qty
1*	Handle Knob Assembly	4
2*	Bolt M8x25	4
3*	Drift Cutter	2

OPTIONAL SKID SHOES

No.	Description	Qty
4*	Plastic Skid Shoe	2